



## TABLE OF CONTENTS

I.	EXECUTIVE SUMMARY .....	3
II.	NOTICES AND COMMUNICATIONS .....	5
III.	BACKGROUND .....	5
A.	Regulatory Framework .....	5
B.	NERC Reliability Standards Development Procedure .....	6
C.	Procedural History of Proposed Reliability Standard TPL-007-2 .....	7
1.	History of Reliability Standard TPL-007-1 and Order No. 830 .....	7
2.	Project 2013-03 Geomagnetic Disturbance Mitigation .....	9
IV.	JUSTIFICATION FOR APPROVAL.....	10
A.	The Supplemental GMD Event.....	11
B.	New and Revised Requirements to Perform GMD Vulnerability Assessments Based on the Supplemental GMD Event .....	14
1.	Proposed Requirement R8 .....	14
2.	Proposed Requirements R9 and R10 .....	16
C.	New Requirements for the Collection of GMD Data (R11 and R12).....	18
D.	Revised Deadlines for Corrective Action Plans in Requirement R7 .....	19
E.	Enforceability of Proposed Reliability Standard TPL-007-2.....	24
V.	EFFECTIVE DATE.....	25
VI.	UPDATE ON NERC’S ONGOING GMD RESEARCH WORK PLAN AND SECTION 1600 GMD DATA REQUEST ACTIVITIES .....	26
VII.	CONCLUSION.....	28
<b>Exhibit A</b>	Proposed Reliability Standard TPL-007-2 – Transmission System Planned Performance for Geomagnetic Disturbance Operations	
<b>Exhibit B</b>	Implementation Plan for Proposed Reliability Standard TPL-007-2	
<b>Exhibit C</b>	Analysis of Violation Risk Factors and Violation Severity Levels	
<b>Exhibit D</b>	Summary of Development History and Complete Record of Development	
<b>Exhibit E</b>	Order No. 672 Criteria for Proposed Reliability Standard TPL-007-2	
<b>Exhibit F</b>	Standard Drafting Team Roster for Project 2013-03	
<b>Exhibit G</b>	Transformer Thermal Impact Assessment White Paper	

## **TABLE OF CONTENTS**

<b>Exhibit H</b>	Screening Criterion for Transformer Thermal Impact Assessment White Paper
<b>Exhibit I</b>	Supplemental GMD Event Description White Paper
<b>Exhibit J</b>	Consideration of Directives

**UNITED STATES OF AMERICA  
BEFORE THE  
FEDERAL ENERGY REGULATORY COMMISSION**

**North American Electric Reliability  
Corporation**

)  
)

**Docket Nos.** \_\_\_\_\_

**PETITION OF THE  
NORTH AMERICAN ELECTRIC RELIABILITY CORPORATION  
FOR APPROVAL OF PROPOSED RELIABILITY STANDARD TPL-007-2**

Pursuant to Section 215(d)(1) of the Federal Power Act (“FPA”)<sup>1</sup> and Section 39.5 of the regulations of the Federal Energy Regulatory Commission (“FERC” or “Commission”),<sup>2</sup> the North American Electric Reliability Corporation (“NERC”)<sup>3</sup> hereby requests Commission approval of proposed Reliability Standard TPL-007-2 (*Transmission System Planned Performance for Geomagnetic Disturbance Events*) (Exhibit A), the associated implementation plan (Exhibit B), the Violation Risk Factors (“VRFs”) and Violation Severity Levels (“VSLs”) (Exhibit C), and the retirement of currently-effective Reliability Standard TPL-007-1. The NERC Board of Trustees (“Board”) adopted proposed Reliability Standard TPL-007-2 on November 9, 2017.

Proposed Reliability Standard TPL-007-2 requires owners and operators of the Bulk Power System (“BPS”) to conduct initial and on-going vulnerability assessments of the potential impact of defined geomagnetic disturbance (“GMD”) events on BPS equipment and the BPS as a whole. The modifications in the proposed standard address the Commission’s directives in Order No. 830.<sup>4</sup> The modifications also improve upon the currently-effective version of the standard by

---

<sup>1</sup> 16 U.S.C. § 824o (2012).

<sup>2</sup> 18 C.F.R. § 39.5 (2017).

<sup>3</sup> The Commission certified NERC as the electric reliability organization (“ERO”) in accordance with Section 215 of the FPA on July 20, 2006. *N. Am. Elec. Reliability Corp.*, 116 FERC ¶ 61,062 (2006).

<sup>4</sup> *Reliability Standard for Transmission System Planned Performance for Geomagnetic Disturbance Events*, Order No. 830, 156 FERC ¶ 61,215, P 1 (2016), *reh’g denied*, Order No. 830-A, 158 FERC ¶ 61,041 (2017).

using the latest developments in GMD research to provide enhanced criteria and requirements to address reliability risks arising from GMDs, including the risks posed by severe, localized events.

NERC requests that the Commission approve the proposed Reliability Standard and related elements as just, reasonable, not unduly discriminatory or preferential, and in the public interest. NERC requests that the Commission approve the proposed standard effective on the first day of the first calendar quarter that is three months after the effective date of the Commission's order approving the proposed standard in accordance with the proposed implementation plan (Exhibit B). As described in further detail herein, the proposed implementation plan is intended to integrate the new requirements in TPL-007-2 with the GMD Vulnerability Assessment<sup>5</sup> process that is currently being implemented through the currently-effective version of the standard.

Pursuant to Section 39.5(a) of the Commission's regulations,<sup>6</sup> this Petition presents the technical basis and purpose of proposed Reliability Standard TPL-007-2 (Exhibits A – D and Exhibits G – J), a summary of the development history (Exhibit D), and a demonstration that the proposed Reliability Standard meets the criteria identified by the Commission in Order No. 672 (Exhibit E).<sup>7</sup>

---

<sup>5</sup> Unless otherwise designated, all capitalized terms shall have the meaning set forth in the *Glossary of Terms Used in NERC Reliability Standards*, available at [http://www.nerc.com/files/Glossary\\_of\\_Terms.pdf](http://www.nerc.com/files/Glossary_of_Terms.pdf).

<sup>6</sup> 18 C.F.R. § 39.5(a).

<sup>7</sup> The Commission specified in Order No. 672 certain general factors it would consider when assessing whether a particular Reliability Standard is just and reasonable. *See Rules Concerning Certification of the Electric Reliability Organization; and Procedures for the Establishment, Approval, and Enforcement of Electric Reliability Standards*, Order No. 672, FERC Stats. & Regs. ¶ 31,204, at PP 262, 321-37, *order on reh'g*, Order No. 672-A, FERC Stats. & Regs. ¶ 31,212 (2006).

## I. EXECUTIVE SUMMARY

Proposed Reliability Standard TPL-007-2 adds enhancements to the currently-effective GMD planning standard, Reliability Standard TPL-007-1, to better address risks to reliability posed by GMDs and to implement the Commission's directives in Order No. 830. In Order No. 830, the Commission approved Reliability Standard TPL-007-1 and directed NERC to modify the standard as follows:

- revise the benchmark GMD event used for GMD Vulnerability Assessments so that the reference peak geoelectric field amplitude component is not based solely on spatially-averaged data;<sup>8</sup>
- revise Requirement R6 to require entities to apply spatially averaged and non-spatially averaged peak geoelectric field values, or some equally efficient and effective alternative, when conducting transformer thermal impact assessments;<sup>9</sup>
- require entities to collect data from geomagnetically induced current ("GIC") monitors and magnetometers as necessary to enable model validation and situational awareness;<sup>10</sup> and
- require entities to develop any necessary Corrective Action Plans within one year from the completion of the GMD Vulnerability Assessment, include a two-year deadline for the implementation of non-hardware mitigation, and include a four-year deadline to complete hardware mitigation.<sup>11</sup>

Proposed Reliability Standard TPL-007-2 reflects the latest in GMD understanding and provides a technically sound and flexible approach to addressing the items of concern noted by the Commission in Order No. 830. The proposed standard addresses the Commission's directives by:

---

<sup>8</sup> See Order No. 830 at P 44.

<sup>9</sup> *Id.* at P 65.

<sup>10</sup> *Id.* at P 88.

<sup>11</sup> *Id.* at P 101-102.

- requiring entities to perform supplemental GMD Vulnerability Assessments based on the supplemental GMD event, a second defined event that accounts for localized peak effects of GMDs and which is based on individual station measurements (i.e. not spatially-averaged data);
- requiring entities to perform supplemental thermal impact assessments of applicable power transformers based on GIC information for the supplemental GMD event;
- requiring entities to implement process(es) to obtain GIC monitor and magnetometer data; and
- implementing the deadlines specified by the Commission in Order No. 830 for the development and completion of any necessary Corrective Action Plans to address system performance issues resulting from the benchmark GMD event.

As discussed in detail below, these revisions would enhance reliability by expanding GMD Vulnerability Assessments to include severe, localized impacts and by implementing new deadlines and processes to maintain accountability in the development, completion, and revision of entity Corrective Action Plans developed to address identified vulnerabilities. Further, the proposed revisions would improve the availability of GMD monitoring data that may be used to inform GMD Vulnerability Assessments. Through its ongoing GMD work, including the GMD Research Work Plan<sup>12</sup> and a forthcoming Request for Data or Information pursuant to Section 1600 of the NERC Rules of Procedure (“Section 1600 GMD Data Request”),<sup>13</sup> NERC expects to obtain useful inputs for continued evaluation of the technical basis that underpins the proposed standard.

---

<sup>12</sup> In accordance with Order No. 830, NERC filed a preliminary work plan to conduct research on topics related to GMDs and their impacts on the reliability of the BPS (the “GMD Research Work Plan”). *See Geomagnetic Disturbance Research Work Plan of the North American Electric Reliability Corporation*, Docket No. RM15-11-002 (May 30, 2017). In accordance with the Commission’s October 19, 2017 *Order on GMD Research Work Plan*, NERC will file a final or otherwise updated GMD Research Work Plan on or before April 2018.

<sup>13</sup> NERC Rules of Procedure Section 1600. The NERC Rules of Procedure are available at <http://www.nerc.com/AboutNERC/Pages/Rules-of-Procedure.aspx>.

For these reasons and as discussed more fully in this Petition, NERC respectfully requests that the Commission approve the proposed standard as just, reasonable, not unduly discriminatory or preferential, and in the public interest.

## **II. NOTICES AND COMMUNICATIONS**

Notices and communications with respect to this filing may be addressed to:<sup>14</sup>

Shamai Elstein\*  
Senior Counsel  
Lauren Perotti\*  
Counsel  
Candice Castaneda\*  
Counsel  
North American Electric Reliability  
Corporation  
1325 G Street, N.W., Suite 600  
Washington, DC 20005  
(202) 400-3000  
(202) 644-8099 – facsimile  
shamai.elstein@nerc.net  
lauren.perotti@nerc.net  
candice.castaneda@nerc.net

Howard Gugel\*  
Senior Director of Standards  
North American Electric Reliability  
Corporation  
3353 Peachtree Road, N.E.  
Suite 600, North Tower  
Atlanta, GA 30326  
(404) 446-2560  
Howard.Gugel@nerc.net

## **III. BACKGROUND**

### **A. Regulatory Framework**

In the Energy Policy Act of 2005,<sup>15</sup> Congress entrusted the Commission with the duties of approving and enforcing rules to ensure the reliability of the BPS. Congress also entrusted the Commission with certifying an Electric Reliability Organization (“ERO”) charged with developing and enforcing mandatory Reliability Standards, subject to Commission approval. Section 215(b)(1) of the FPA states that all users, owners, and operators of the BPS in the United

---

<sup>14</sup> Persons to be included on the Commission’s service list are identified by an asterisk. NERC respectfully requests a waiver of Rule 203 of the Commission’s regulations, 18 C.F.R. § 385.203, to allow the inclusion of more than two persons on the service list in this proceeding.

<sup>15</sup> 16 U.S.C. § 824o.



States will be subject to Commission-approved Reliability Standards.<sup>16</sup> Section 215(d)(5) of the FPA authorizes the Commission to order the ERO to submit a new or modified Reliability Standard.<sup>17</sup> Section 39.5(a) of the Commission’s regulations requires the ERO to file with the Commission for its approval each Reliability Standard that the ERO proposes should become mandatory and enforceable in the United States and each modification to a Reliability Standard that the ERO proposes should be made effective.<sup>18</sup>

The Commission is vested with the regulatory responsibility to approve Reliability Standards that protect the reliability of the BPS and to ensure that such Reliability Standards are just, reasonable, not unduly discriminatory or preferential, and in the public interest. Pursuant to Section 215(d)(2) of the FPA<sup>19</sup> and Section 39.5(c) of the Commission’s regulations, “the Commission will give due weight to the technical expertise of the Electric Reliability Organization” with respect to the content of a Reliability Standard.<sup>20</sup>

## **B. NERC Reliability Standards Development Procedure**

The proposed Reliability Standard was developed in an open and fair manner and in accordance with the Commission-approved Reliability Standard development process.<sup>21</sup> NERC develops Reliability Standards in accordance with Section 300 (Reliability Standards Development) of its Rules of Procedure and the NERC Standard Processes Manual.<sup>22</sup>

---

<sup>16</sup> *Id.* § 824o(b)(1).

<sup>17</sup> *Id.* § 824o(d)(5).

<sup>18</sup> 18 C.F.R. § 39.5(a).

<sup>19</sup> 16 U.S.C. § 824o(d)(2).

<sup>20</sup> 18 C.F.R. § 39.5(c)(1).

<sup>21</sup> *Rules Concerning Certification of the Electric Reliability Organization; and Procedures for the Establishment, Approval, and Enforcement of Electric Reliability Standards*, Order No. 672 at P 334, FERC Stats. & Regs. ¶ 31,204, *order on reh’g*, Order No. 672-A, FERC Stats. & Regs. ¶ 31,212 (2006).

<sup>22</sup> The ROP is available at <http://www.nerc.com/AboutNERC/Pages/Rules-of-Procedure.aspx>. The NERC *Standard Processes Manual* is available at [http://www.nerc.com/comm/SC/Documents/Appendix\\_3A\\_StandardsProcessesManual.pdf](http://www.nerc.com/comm/SC/Documents/Appendix_3A_StandardsProcessesManual.pdf).

In its order certifying NERC as the Commission’s ERO, the Commission found that NERC’s proposed rules provide for reasonable notice and opportunity for public comment, due process, openness, and a balance of interests in developing Reliability Standards,<sup>23</sup> and thus satisfy certain of the criteria for approving Reliability Standards.<sup>24</sup> The development process is open to any person or entity with a legitimate interest in the reliability of the BPS. NERC considers the comments of all stakeholders, and stakeholders must approve, and the NERC Board of Trustees must adopt, a Reliability Standard before the Reliability Standard is submitted to the Commission for approval.

### **C. Procedural History of Proposed Reliability Standard TPL-007-2**

This section summarizes the development history of proposed Reliability Standard TPL-007-2.

#### **1. History of Reliability Standard TPL-007-1 and Order No. 830**

On January 21, 2015, NERC filed a petition requesting Commission approval of Reliability Standard TPL-007-1, the second-stage GMD Reliability Standard contemplated by the Commission in Order No. 779.<sup>25</sup> Reliability Standard TPL-007-1 requires applicable entities to conduct initial and ongoing assessments of the potential impact of a 1-in-100 year benchmark GMD event on BPS equipment and the BPS as a whole. The Commission approved Reliability Standard TPL-007-1 in Order No. 830, issued on September 22, 2016, stating that the standard “constitutes an important step in addressing the risks posed by GMD events to the Bulk-Power

---

<sup>23</sup> *N. Am. Elec. Reliability Corp.*, 116 FERC ¶ 61,062 at P 250 (2006).

<sup>24</sup> Order No. 672 at PP 268, 270.

<sup>25</sup> *Petition of the North American Electric Reliability Corporation for Approval of Reliability Standard TPL-007-1 Transmission System Planned Performance for Geomagnetic Disturbance Events*, Docket No. RM15-11-000 (Jan. 21, 2015); *Reliability Standards for Geomagnetic Disturbances*, Order No. 779, 78 Fed. Reg. 30,747 (May 23, 2013), 143 FERC ¶ 61,147, *reh’g denied*, 144 FERC ¶ 61,113 (2013) (directing the development of Reliability Standards to address GMDs in two stages).

System.”<sup>26</sup> The Commission also directed four revisions to the standard to address areas of concern noted in the order and underlying proceeding.

First, noting its concerns with the reliance on spatially averaged data in the TPL-007-1 benchmark GMD event definition, the Commission directed NERC to “develop revisions to the benchmark GMD event definition so that the reference peak geoelectric field amplitude component is not based solely on spatially-averaged data.”<sup>27</sup> The Commission also directed NERC to revise Requirement R6 “to require registered entities to apply spatially averaged and non-spatially averaged peak geoelectric field values, or some equally and efficient alternative, when conducting thermal impact assessments.”<sup>28</sup>

Next, the Commission directed NERC to revise TPL-007-1 to require entities “to collect GIC monitoring and magnetometer data as necessary to enable model validation and situational awareness, including from any devices that must be added to meet this need.”<sup>29</sup> The Commission stated that “additional collection and disclosure of GIC monitoring and magnetometer data is necessary to improve our collective understanding of the threats posed by GMD events.”<sup>30</sup>

Lastly, the Commission directed NERC to modify TPL-007-1 requirements for Corrective Action Plans to include: (i) a one-year deadline for the development of any necessary Corrective Action Plans; (ii) a two-year deadline for the implementation of non-hardware mitigation; and (iii) a four-year deadline for the implementation of hardware mitigation.<sup>31</sup>

---

<sup>26</sup> Order No. 830 at P 1.

<sup>27</sup> Order No. 830 at P 44.

<sup>28</sup> *Id.* at P 65.

<sup>29</sup> *Id.* at P 88.

<sup>30</sup> *Id.*

<sup>31</sup> *Id.* at PP 101-102.

In addition to these standard modification directives, the Commission also directed NERC to undertake certain activities to improve understanding of GMDs and their potential impacts on power systems. First, the Commission directed NERC to submit a work plan describing how NERC would research specific GMD-related topics identified by the Commission and other topics at NERC's discretion.<sup>32</sup> Second, the Commission directed NERC to collect GIC and magnetometer data pursuant to Section 1600 of the NERC Rules of Procedure, including existing data for the period beginning May 2013 and new data going forward, and to make that information available to support ongoing GMD research and analysis.<sup>33</sup>

This filing describes how proposed Reliability Standard TPL-007-2 addresses the standard modification directives described above. NERC continues its efforts to address the Commission's work plan and data collection directives and provides a status update on those efforts for the Commission's information in Section VI, below. NERC anticipates that the results of these efforts will inform future reviews of the proposed Reliability Standard.

## **2. Project 2013-03 Geomagnetic Disturbance Mitigation**

Shortly after the issuance of Order No. 830, NERC initiated a new phase of Project 2013-03 to address the Commission's directives to modify Reliability Standard TPL-007-1. As with prior phases of the project, the standard drafting team for this phase consisted of individuals with extensive planning, engineering, and scientific knowledge and experience. To provide technical support for proposed Reliability Standard TPL-007-2, the standard drafting team developed new and updated supporting materials, including the Supplemental GMD Event Description White

---

<sup>32</sup> See generally *id.* at P 77.

<sup>33</sup> Order No. 830 at PP 89, 93.

Paper (Exhibit I), Screening Criterion for Transformer Thermal Impact Assessment White Paper (Exhibit H), and Transformer Thermal Impact Assessment White Paper (Exhibit G).

Proposed Reliability Standard TPL-007-2 was posted for initial ballot from June 28, 2017 to August 11, 2017 and for final ballot from October 20, 2017 to October 30, 2017. The NERC Board of Trustees adopted the proposed standard on November 9, 2017. The complete development history of proposed Reliability Standard TPL-007-2 is attached as Exhibit D.

#### **IV. JUSTIFICATION FOR APPROVAL**

As discussed below and in Exhibit E, proposed Reliability Standard TPL-007-2 satisfies the Commission's criteria in Order No. 672 and is just, reasonable, not unduly discriminatory or preferential, and in the public interest. The proposed Reliability Standard contains significant benefits for the BPS and addresses the Commission's directives from Order No. 830.

The purpose of proposed Reliability Standard TPL-007-2, which remains unchanged from currently-effective Reliability Standard TPL-007-1, is to "[e]stablish requirements for Transmission system planned performance during geomagnetic disturbance (GMD) events." The applicability of the proposed standard also remains unchanged from TPL-007-1: the proposed standard would continue to apply to: (1) Planning Coordinators and Transmission Planners whose planning areas have a Facility that includes a power transformer with a high side, wye-grounded winding with terminal voltage greater than 200 kV<sup>34</sup>; and (2) Transmission Owners and Generator Owners that own a Facility that includes such equipment.

Currently-effective Reliability Standard TPL-007-1 requires entities to conduct initial and on-going assessments of the potential impact of the defined benchmark GMD event on BPS equipment and the BPS as a whole. Proposed Reliability Standard TPL-007-2 builds upon these

---

<sup>34</sup> A power transformer with a "high side wye-grounded winding" refers to a power transformer with windings on the high voltage side that are connected in a wye configuration and have a grounded neutral connection.

Requirements and adds new Requirements for entities to assess their vulnerabilities to a second defined event, the supplemental GMD event. This supplemental GMD event is designed to account for the localized peak effects of severe GMD events on systems and equipment. The proposed standard also contains new Requirements for the collection of GIC and magnetometer data. Lastly, the proposed standard revises Requirement R7 to include deadlines for the development and completion of any necessary Corrective Action Plans. Each of these revisions and how they address the Commission's directives from Order No. 830 is discussed below.

**A. The Supplemental GMD Event**

Proposed Reliability Standard TPL-007-2 contains new Requirements for entities to assess their vulnerabilities to a second defined GMD event, the supplemental GMD event. As described in the Supplemental GMD Event Description White Paper (Exhibit I), geomagnetic fields during severe GMD events can be spatially non-uniform with higher and lower strengths across a geographic region. The supplemental GMD event, which was derived using individual station measurements rather than spatially averaged measurements, includes localized enhancement of field strength above the average value. As such, the proposed standard addresses the Commission's directive in Order No. 830 to revise the GMD standard to account for the effects of localized peaks that could potentially affect reliable operations.<sup>35</sup>

The benchmark GMD event and the supplemental GMD event are similar in structure but the supplemental GMD event contains several differences to account for localized impacts. Like

---

<sup>35</sup> See Order No. 830 at P 44 ("The Commission...directs NERC to develop revisions to the benchmark GMD event definition so that the reference peak geoelectric field amplitude component is not based solely on spatially-averaged data."). See also Order No. 830 at P 47 ("Without pre-judging how NERC proposes to address the Commission's directive, NERC's response to this directive should satisfy the NOPR's concern that reliance on spatially-averaged data alone does not address localized peaks that could potentially affect the reliable operation of the Bulk-Power System.")

the benchmark GMD event, the supplemental GMD event defines the geomagnetic and geoelectric field values used to compute GIC flows for use in a GMD Vulnerability Assessment.

The benchmark GMD event is composed of the following components:

- a reference peak geoelectric field amplitude of 8 V/km derived from statistical analysis of historical magnetometer data;
- scaling factors to account for local geomagnetic latitude;
- scaling factors to account for local earth conductivity; and
- a reference geomagnetic field time series or waveform to facilitate time-domain analysis of GMD impact on equipment.

The supplemental GMD event has the same components, except that the reference peak geoelectric field amplitude is 12 V/km over a localized area (compared to 8 V/km) and the geomagnetic field time series or waveform includes a local enhancement.<sup>36</sup> These distinguishing characteristics of the supplemental GMD event are intended to represent conditions associated with localized enhancement of the geomagnetic field during a severe GMD event for use in assessing GMD impacts.

In developing the supplemental GMD event, the standard drafting team used data and information so that the peak geoelectric field does not rely on spatial averaging of geomagnetic field data. Like the value in the approved benchmark GMD event, the supplemental GMD event peak geoelectric field is a 1-in-100 year extreme value determined using statistical analysis of historical geomagnetic field data. The fundamental difference in the supplemental GMD event amplitude is that it is based on geomagnetic field observations taken at individual observation stations (i.e., localized measurements), instead of the spatially averaged geoelectric fields used in

---

<sup>36</sup> See proposed Reliability Standard TPL-007-2 Attachment 1. See also Supplemental GMD Event Description White Paper (Exhibit I). The addition of a local enhancement to the supplemental GMD event waveform also causes some small changes in earth conductivity scaling factors, as explained in the white paper. These earth conductivity scaling factors for the supplemental GMD event are included in proposed TPL-007-2 Attachment 1.

the benchmark GMD event. The result of the extreme value analysis shows that the supplemental GMD event peak of 12 V/km is above the upper limit of the 95 percent confidence interval for a 100-year return interval, while the same confidence interval with spatially-averaged data (i.e., the benchmark GMD event) is 8 V/km. Thus, GMD Vulnerability Assessments based on the 12 V/km peak geoelectric field of the proposed supplemental GMD event are considering extreme localized conditions associated with a 1-in-100 year severe GMD event.

Similar to the benchmark GMD event, the supplemental GMD event includes a waveform for assessing transformer thermal impacts from a severe GMD event. Both the benchmark and supplemental GMD event waveforms are based on 10-second sampling interval magnetic field data from the Ottawa observatory recorded during the March 13-14, 1989 GMD event. The supplemental GMD event waveform is more severe than the benchmark GMD event waveform because it includes a five-minute duration enhanced peak up to 12 V/km for the reference earth model and 60 degree geomagnetic latitude. This synthetic enhancement represents the observed localized, rapid magnetic field variation periods associated with ionospheric sources during some severe GMD events. Such GMD conditions could result in increased transformer heating for short durations during a severe GMD event due to increased GIC flows.

The supplemental GMD event provides a technically justified method of assessing vulnerabilities to the localized peak effects of severe GMD events, thereby addressing the Commission's Order No. 830 directive. Together, the approved benchmark GMD event and the proposed supplemental GMD event provide a high threshold for assessing GMD impacts.



**B. New and Revised Requirements to Perform GMD Vulnerability Assessments Based on the Supplemental GMD Event**

Proposed TPL-007-2 adds new Requirements R8, R9, and R10 to require responsible entities to assess the potential implications of the supplemental GMD event described above on their equipment and systems in accordance with the Commission’s directives in Order No. 830.<sup>37</sup> The proposed Requirements are structured and worded similarly to approved Requirements R4 through R6, which require entities to assess the impact of the benchmark GMD event. With the addition of these new Requirements, NERC proposes minor revisions to Requirements R4 through R6 to clarify that those existing Requirements pertain to assessments based on the benchmark GMD event. NERC also proposes revisions to Requirements R1 through R3 to include appropriate references to the supplemental GMD event. These minor revisions are shown in Exhibit A (redline).

**1. Proposed Requirement R8**

Proposed Requirement R8 would require responsible entities to complete a supplemental GMD Vulnerability Assessment of the Near-Term Transmission Planning Horizon at least once every five years. The proposed Requirement reads as follows:

- R8.** Each responsible entity, as determined in Requirement R1, shall complete a supplemental GMD Vulnerability Assessment of the Near-Term Transmission Planning Horizon at least once every 60 calendar months. This supplemental GMD Vulnerability Assessment shall use a study or studies based on models identified in Requirement R2, document assumptions, and document summarized results of the steady state analysis.
- 8.1.** The study or studies shall include the following conditions:
    - 8.1.1.** System On-Peak Load for at least one year within the Near-Term Transmission Planning Horizon; and
    - 8.1.2.** System Off-Peak Load for at least one year within the Near-Term Transmission Planning Horizon.
  - 8.2.** The study or studies shall be conducted based on the supplemental GMD event described in Attachment 1 to determine whether the System meets the

---

<sup>37</sup> See Order No. 830 at P 44 (benchmark GMD event definition) and P 65 (transformer thermal impact assessments).

performance requirements for the steady state planning supplemental GMD event contained in Table 1.

- 8.3.** If the analysis concludes there is Cascading caused by the supplemental GMD event described in Attachment 1, an evaluation of possible actions designed to reduce the likelihood or mitigate the consequences and adverse impacts of the event(s) shall be conducted.
- 8.4.** The supplemental GMD Vulnerability Assessment shall be provided: (i) to the responsible entity's Reliability Coordinator, adjacent Planning Coordinators, adjacent Transmission Planners within 90 calendar days of completion, and (ii) to any functional entity that submits a written request and has a reliability-related need within 90 calendar days of receipt of such request or within 90 calendar days of completion of the supplemental GMD Vulnerability Assessment, whichever is later.
  - 8.4.1.** If a recipient of the supplemental GMD Vulnerability Assessment provides documented comments on the results, the responsible entity shall provide a documented response to that recipient within 90 calendar days of receipt of those comments.

Proposed Requirement R8 mirrors Requirement R4, which requires entities to complete a GMD Vulnerability Assessment based on the benchmark GMD event, but with one key difference. Proposed Requirement R8 contains an additional Part, Part 8.3, which provides that if analysis concludes there would be Cascading caused by the supplemental GMD event, the responsible entity must then evaluate possible actions to reduce the likelihood or mitigate consequences and adverse impacts of the event. As discussed more fully in Section IV.D below, the standard drafting team determined that requiring such an evaluation of possible actions, as opposed to a formal Corrective Action Plan, would provide a more prudent approach in light of the limitations of currently-available tools for modeling localized GMD effects.

New language is reflected in proposed Requirement R8 Part 8.4 to clarify the timeframe for providing completed supplemental GMD Vulnerability Assessments to the Reliability Coordinator, neighboring Planning Coordinators and Transmission Planners, and to the other functional entities with a reliability-related need that submit a request. To provide for

consistency across similar Requirements, conforming revisions are proposed in TPL-007-2 Requirement R4 Part 4.3 pertaining to benchmark GMD Vulnerability Assessments.

## **2. Proposed Requirements R9 and R10**

Proposed Requirements R9 and R10 pertain to supplemental transformer thermal impact assessments. As these Requirements are based on the supplemental GMD event described above, they address the Commission's directive to revise the standard to require entities to apply non spatially-averaged peak geoelectric field values when conducting thermal impact assessments.<sup>38</sup>

Proposed Requirement R9 would require responsible entities to provide GIC flow information based on the supplemental GMD event to owners of applicable BES power transformers in the planning area. The proposed Requirement mirrors existing Requirement R5 pertaining to GIC flow information for the benchmark GMD event. Proposed Requirement R9 reads as follows:

- R9.** Each responsible entity, as determined in Requirement R1, shall provide GIC flow information to be used for the supplemental thermal impact assessment of transformers specified in Requirement R10 to each Transmission Owner and Generator Owner that owns an applicable Bulk Electric System (BES) power transformer in the planning area. The GIC flow information shall include:
- 9.1.** The maximum effective GIC value for the worst case geoelectric field orientation for the supplemental GMD event described in Attachment 1. This value shall be provided to the Transmission Owner or Generator Owner that owns each applicable BES power transformer in the planning area.
  - 9.2.** The effective GIC time series, GIC(t), calculated using the supplemental GMD event described in Attachment 1 in response to a written request from the Transmission Owner or Generator Owner that owns an applicable BES power transformer in the planning area. GIC(t) shall be provided within 90 calendar days of receipt of the written request and after determination of the maximum effective GIC value in Part 9.1.

---

<sup>38</sup>

Order No. 830 at P 65.

Proposed Requirement R10 would require each Transmission Owner and Generator Owner to conduct a supplemental thermal impact assessment for solely and jointly owned applicable BES power transformers where the maximum effective GIC value resulting from Requirement R9 is above a specific threshold. The proposed Requirement reads as follows:

- R10.** Each Transmission Owner and Generator Owner shall conduct a supplemental thermal impact assessment for its solely and jointly owned applicable BES power transformers where the maximum effective GIC value provided in Requirement R9, Part 9.1, is 85 A per phase or greater. The supplemental thermal impact assessment shall:
- 10.1.** Be based on the effective GIC flow information provided in Requirement R9;
  - 10.2.** Document assumptions used in the analysis;
  - 10.3.** Describe suggested actions and supporting analysis to mitigate the impact of GICs, if any; and
  - 10.4.** Be performed and provided to the responsible entities, as determined in Requirement R1, within 24 calendar months of receiving GIC flow information specified in Requirement R9, Part 9.1.

Proposed Requirement R10 mirrors existing Requirement R6 pertaining to transformer thermal impact assessments based on the benchmark GMD event. However, for the supplemental thermal impact assessment, the threshold is a maximum effective GIC value of 85 A per phase or greater (compared to the benchmark threshold of 75 A per phase or greater). As described in greater detail in the Screening Criterion for Transformer Thermal Impact Assessment White Paper (Exhibit H), the threshold value is determined using the same methods employed for the benchmark thermal impact assessments and provides that assessments be performed on all applicable power transformers that could potentially exceed emergency loading temperature guidelines.<sup>39</sup>

---

<sup>39</sup> See generally Exhibit H and Institute of Electrical and Electronic Engineers (IEEE) Standard C57.91-2011 – Guide for Loading Mineral-Oil-Immersed Transformers and Step-Voltage Regulators.

### **C. New Requirements for the Collection of GMD Data (R11 and R12)**

In Order No. 830, the Commission directed NERC to “develop revisions to Reliability Standard TPL-007-1 to require responsible entities to collect GIC monitoring and magnetometer data as necessary to enable model validation and situational awareness, including from any devices that must be added to meet this need.”<sup>40</sup> Consistent with this directive, proposed TPL-007-2 contains two new Requirements, Requirements R11 and R12, that would require responsible entities to implement a process to obtain GIC monitor and geomagnetic field data for their planning area or system model area. The Requirements apply to Planning Coordinators and Transmission Planners, as determined in Requirement R1, because these entities are responsible for maintaining GIC System models (Requirement R2). Entities may use the data for validating GIC system models as well as for awareness of local geomagnetic conditions and measured GIC levels.

Proposed Requirement R11 would require responsible entities to implement a process to obtain GIC monitor data as follows:

**R11.** Each responsible entity, as determined in Requirement R1, shall implement a process to obtain GIC monitor data from at least one GIC monitor located in the Planning Coordinator’s planning area or other part of the system included in the Planning Coordinator’s GIC System model.

Consistent with the Commission’s guidance,<sup>41</sup> collection criteria are included in the Supplemental Material section of the proposed standard to promote consistency and provide entities with flexibility to tailor procedures to their planning area. The guidance for GIC data collection addresses monitor locations, monitor specifications, sampling interval, collection periods, data format, and data retention.

---

<sup>40</sup> Order No. 830 at P 88.

<sup>41</sup> *See id.* at P 91 (regarding criteria for NERC to consider in developing a requirement for the collection of GIC monitoring data).

Proposed Requirement R12 would require responsible entities to implement a process to obtain geomagnetic field data as follows:

**R12.** Each responsible entity, as determined in Requirement R1, shall implement a process to obtain geomagnetic field data for its Planning Coordinator's planning area.

By requiring responsible entities to obtain geomagnetic field data for their planning areas, the proposed Requirement would ensure that data is obtained from diverse geographic areas of the North American BPS. Entities are advised to obtain data from the nearest accessible magnetometer. Sources of magnetometer data include government observatories, installed equipment owned or operated by the entity, and third party sources, including research institutions and universities. Entities that choose to install their own magnetometers are referred to the *INTERMAGNET Technical Reference Manual* for equipment specifications and data format protocols.

Proposed Reliability Standard TPL-007-2 supports future data collection across the North American BPS by requiring planning entities to implement processes for obtaining GMD data for each planning area. NERC, pursuant to the pending Section 1600 GMD Data Request,<sup>42</sup> will collect GMD data from entities and make that data available to support ongoing research and analysis of GMD risk. The proposed standard, together with the pending Section 1600 GMD Data Request, would thus satisfy the Commission's data collection directives in Order No. 830 and provide data to help address the potential reliability risks posed by GMDs.

#### **D. Revised Deadlines for Corrective Action Plans in Requirement R7**

NERC proposes to revise Requirement R7 to include the Commission-directed deadlines for the development and completion of any required Corrective Action Plans to address system

---

<sup>42</sup> See Section VI *infra*.

performance issues for the benchmark GMD event. In Order No. 830, the Commission directed NERC to modify the TPL-007 standard to include the following deadlines:

- one year from the completion of the GMD Vulnerability Assessment to complete the development of a Corrective Action Plan;
- two years after the development of the Corrective Action Plan to complete the implementation of non-hardware mitigation; and
- four years after the development of the Corrective Action Plan to complete hardware mitigation.”<sup>43</sup>

Proposed TPL-007-2 Requirement R7 revises the existing standard to incorporate these directives as follows:

**R7.** Each responsible entity, as determined in Requirement R1, that concludes, through the benchmark GMD Vulnerability Assessment conducted in Requirement R4, that their System does not meet the performance requirements ~~of~~ for the steady state planning benchmark GMD event contained in Table 1, shall develop a Corrective Action Plan (CAP) addressing how the performance requirements will be met. ~~The Corrective Action Plan~~ CAP shall:

- 7.1.** List System deficiencies and the associated actions needed to achieve required System performance. Examples of such actions include:
  - Installation, modification, retirement, or removal of Transmission and generation Facilities and any associated equipment.
  - Installation, modification, or removal of Protection Systems or ~~Special Protection Systems~~ Remedial Action Schemes.
  - Use of Operating Procedures, specifying how long they will be needed as part of the ~~Corrective Action Plan~~ CAP.
  - Use of Demand-Side Management, new technologies, or other initiatives.
- 7.2.** ~~Be reviewed in subsequent~~ developed within one year of completion of the benchmark GMD Vulnerability Assessments until it is determined that the System meets the performance requirements contained in Table 1.
- 7.3.** Include a timetable, subject to revision by the responsible entity in Part 7.4, for implementing the selected actions from Part 7.1. The timetable shall:
  - 7.3.1.** Specify implementation of non-hardware mitigation, if any, within two years of development of the CAP; and
  - 7.3.2.** Specify implementation of hardware mitigation, if any, within four years of development of the CAP.

---

<sup>43</sup> Order No. 830 at PP 101-102.

- 7.4.** Be revised if situations beyond the control of the responsible entity determined in Requirement R1 prevent implementation of the CAP within the timetable for implementation provided in Part 7.3. The revised CAP shall document the following, and be updated at least once every 12 calendar months until implemented:
- 7.4.1.** Circumstances causing the delay for fully or partially implementing the selected actions in Part 7.1;
- 7.4.2.** Description of the original CAP, and any previous changes to the CAP, with the associated timetable(s) for implementing the selected actions in Part 7.1; and
- 7.4.3.** Revisions to the selected actions in Part 7.1, if any, including utilization of Operating Procedures if applicable, and the updated timetable for implementing the selected actions.
- 7.37.5.** Be provided ~~within 90 calendar days of completion:~~ (i) to the responsible entity's Reliability Coordinator, adjacent Planning Coordinator(s), adjacent Transmission Planner(s), and functional entities referenced in the Corrective Action Plan CAP within 90 calendar days of development or revision, and (ii) to any functional entity that submits a written request and has a reliability-related need within 90 calendar days of receipt of such request or within 90 calendar days of development or revision, whichever is later.
- 7.3.17.5.1.** If a recipient of the ~~Corrective Action Plan~~ CAP provides documented comments on the results, the responsible entity shall provide a documented response to that recipient within 90 calendar days of receipt of those comments.

Revised Requirement R7 Part 7.2 would require responsible entities to develop a Corrective Action Plan within one year of the benchmark GMD Vulnerability Assessment, if the entity concludes that its System does not meet the performance requirements for the steady state planning benchmark GMD event. Under new Requirement R7 Part 7.3, the Corrective Action Plan shall include a timeline that specifies the completion of non-hardware and hardware mitigation within two and four years of development of the Corrective Action Plan, respectively.

In accordance with the Commission's directive, the proposed standard requires entities to take prompt action to address any vulnerabilities they identify in their systems. The proposed standard recognizes, however, that there may be circumstances outside of an entity's control that could prevent the completion of a mitigation activity by the specified timetable. Such events



could include, for example: delays due to the regulatory or legal processes, such as permitting; delays from stakeholder processes required by tariffs; delays resulting from equipment lead times; or delays resulting from the inability to acquire necessary right-of-way. In such circumstances, an entity may maintain compliance with the standard by revising its Corrective Action Plan in accordance with Requirement R7 Part 7.4.

Under Part 7.4, the entity shall revise its Corrective Action Plan if events beyond its control prevent implementation of the Corrective Action Plan within the original timetable. In the revised Corrective Action Plan, the responsible entity must provide justification for its revised timetable by documenting: (1) the circumstances causing the delay; (2) description of the original Corrective Action Plan and any changes; and (3) revisions to selected actions, including the use of any operating procedures if applicable, along with an updated timetable for completion. The revised Corrective Action Plan shall be updated at least annually. The responsible entity must then provide its revised Corrective Action Plan to recipients of the original Corrective Action Plan (i.e., Reliability Coordinator, adjacent Planning Coordinator(s), adjacent Transmission Planner(s), functional entities referenced in the Corrective Action Plan, and any functional entity that submits a written request and has a reliability related need for the information.) Thus, Requirement R7 would implement the Commission directed deadlines for Corrective Action Plans and mitigation, along with a process to maintain accountability and communication with affected entities when circumstances beyond a responsible entity's control affect the entity's ability to complete implementation within the original deadlines.

This approach is consistent with other Commission-approved Reliability Standards. For example, Reliability Standard FAC-003-4 Requirement R7 provides that an entity may modify its annual vegetation work plan in light of circumstances beyond the entity's control, such as a

natural disaster or other circumstance. (FAC-003-4 Requirement R7 also specifies other acceptable reasons for modifying an annual work plan, including permitting delays.) Reliability Standard PRC-004-5(i) Requirement R5 states that a responsible entity that owns a Protection System component that caused a Misoperation shall either develop a Corrective Action Plan or explain in a declaration why corrective actions are beyond the entity's control or would not improve reliability. In light of the potential planning, siting, budgeting approval, and regulatory uncertainties associated with transmission projects that are outside of an entity's control, it is appropriate to include such a flexible approach to GMD Corrective Action Plan deadlines in proposed TPL-007-2.

As noted above, proposed Requirement R7 continues to apply only where an entity has identified system performance issues through the benchmark GMD Vulnerability Assessment. Mitigation considerations for vulnerabilities identified through the supplemental GMD Vulnerability Assessment are addressed in proposed Requirement R8 Part 8.3. Under this Part, if a responsible entity concludes that there would be Cascading caused by the supplemental GMD event, the entity shall conduct an analysis of possible actions to reduce the likelihood or mitigate the impacts of the event.

The standard drafting team determined that requiring formal Corrective Action Plans based on assessments of the supplemental GMD event would not be appropriate at this time. As discussed in the Supplemental GMD Event Description white paper, the supplemental GMD event is based on a small number of observed localized enhanced geoelectric field events that provide only general insight into the geographic size of localized events during severe solar storms. Additionally, currently available modeling tools do not provide entities with capabilities to model localized enhancements within a severe GMD event realistically. As a result, entities

may need to employ conservative approaches when performing the supplemental GMD Vulnerability Assessment, such as applying the localized peak geoelectric field over an entire planning area. For these reasons, requiring mandatory mitigation may not provide effective reliability benefit or use resources optimally. The approach used in the proposed standard for the supplemental GMD event provides entities with flexibility to consider and select mitigation actions based on their circumstances and is similar to the approach used in Reliability Standard TPL-001-4 Requirement R3 Part 3.5 for extreme events.

**E. Enforceability of Proposed Reliability Standard TPL-007-2**

Proposed Reliability Standard TPL-007-2 includes Measures in support of each Requirement to ensure that Requirements are enforced in a clear, consistent, non-preferential manner, without prejudice to any party. The proposed standard also includes VRFs and VSLs for each Requirement, which are used to help determine appropriate sanctions if an applicable entity violates a Requirement. VRFs assess the impact to reliability of violating a specific Requirement, while VSLs provide guidance on the way that NERC will enforce Requirements.

The proposed standard includes the same VRFs and VSLs for Requirements R1 through R7, which were approved by the Commission in Order No. 830. Proposed Requirement R8 would apply a High VRF; proposed Requirements R9 and R10 would apply a Medium VRF; and Requirements R11 and R12 would apply a Lower VRF. Proposed Requirements R8 through R10 would also apply a graduated scale of Lower to Severe VSLs (depending on the extent of the violation), while proposed Requirements R11 and R12 would only apply a Severe VSL in recognition of the binary nature of compliance with the data obligations.

These VRFs and VSLs comport with NERC and Commission guidelines. The High VRF proposed for Requirement R8 is consistent with both Reliability Standard TPL-001-4 (requiring

an annual planning assessment) and Reliability Standard TPL-007-1 Requirement R4. Further failure to complete a supplemental GMD Vulnerability Assessment could, under certain conditions, place the BES at unacceptable risk. The Medium VRF proposed for Requirements R9 and R10 is similarly consistent with TPL-007-1 Requirements R5 and R6, which require responsible entities to provide GIC data to Transmission Owners and Generator Owners for assessments. In addition, failure to provide GIC flow information or conduct a supplemental transformer impact assessment is unlikely to lead to BES instability, separation, or cascading. The Lower VRF proposed for Requirements R11 and R12 is also consistent with other standards, such as the data collection related obligations in Reliability Standards MOD-032-1 Requirement R1 and IRO-010-2 Requirement R1. Finally, a Lower VRF for both Requirement R11 and R12 would also be appropriate, as an entity's failure to follow its process to obtain GIC monitor or geomagnetic field data would not be expected to adversely affect the electrical state or capability of the BES, or the ability to effectively monitor, control, or restore the BES. Please see Exhibit C for more detailed analysis of the proposed VRFs and VSLs.

## **V. EFFECTIVE DATE**

NERC respectfully requests that the Commission approve NERC's proposed implementation plan, attached to this Petition as Exhibit B. Under this plan, proposed Reliability Standard TPL-007-2 would become effective on the first day of the first calendar quarter that is three months after Commission approval. NERC requests retirement of Reliability Standard TPL-007-1 immediately prior to the effective date of TPL-007-2.

The proposed TPL-007-2 implementation plan recognizes that several Requirements in TPL-007-1 are or will soon become effective, and that many entities may now be taking steps to complete the studies or assessments required by other Requirements in TPL-007-1 that will become enforceable in the future. The proposed implementation plan thus contains two phased

compliance timelines depending on whether proposed Reliability Standard TPL-007-2 standard becomes effective before January 1, 2021 or on/after January 1, 2021:<sup>44</sup>

- If the proposed standard becomes effective before **January 1, 2021**, a new phased compliance schedule would support entities completing Requirements for the supplemental GMD Vulnerability Assessment concurrently with Requirements for the benchmark GMD Vulnerability Assessment.<sup>45</sup>
- If the standard becomes effective on or after **January 1, 2021**, entities would continue work on benchmark GMD Vulnerability Assessments and complete supplemental GMD Vulnerability Assessments during the next assessment cycle.

Under either timeline, entities would be required to comply with Requirements for the collection of GMD monitoring data within 24 months of the effective date of the standard. The phased-in compliance dates provided in the proposed implementation plan appropriately balance the reliability need to implement the new and revised Requirements while providing entities with sufficient time to meet their obligations.

## **VI. UPDATE ON NERC'S ONGOING GMD RESEARCH WORK PLAN AND SECTION 1600 GMD DATA REQUEST ACTIVITIES**

As noted earlier in this Petition, NERC is continuing work to address the Commission's GMD research and data collection directives from Order No. 830. On May 30, 2017, NERC submitted a preliminary version of its GMD Research Work Plan in Docket No. RM15-11-002 describing how NERC would oversee research into the specific GMD topics of interest identified by the Commission.<sup>46</sup> NERC is working with the Electric Power Research Institute ("EPRI") to

---

<sup>44</sup> Under the TPL-007-1 implementation plan, this is the date by which entities would be required to comply with TPL-007-1 Requirement R6 pertaining to transformer thermal impact assessments based on the benchmark GMD event.

<sup>45</sup> Depending on the date of Commission approval of TPL-007-2, the phased compliance dates for completing steps for both benchmark and supplemental GMD Vulnerability Assessments may be slightly delayed from the dates set forth for benchmark GMD Vulnerability Assessments under the TPL-007-1 implementation plan.

<sup>46</sup> *Geomagnetic Disturbance Research Work Plan of the North American Electric Reliability Corporation*, Docket No. RM15-11-002 (May 30, 2017).

prepare an updated GMD Research Work Plan to submit to the Commission by April 2018 in accordance with the Commission's October 19, 2017 Order.<sup>47</sup> NERC and EPRI initiated the GMD Research Work plan in November 2017 through an EPRI project that is supported by utility and Independent System Operator participants and involves NERC GMD Task Force, U.S. national laboratories, equipment manufacturers, and other North American research partners.

To address the Commission's Order No. 830 data collection directive, NERC recently prepared an initial draft Request for Data or Information under Section 1600 of the NERC Rules of Procedure. The draft was prepared in conjunction with the NERC GMD Task Force under the oversight of the NERC Planning Committee. In accordance with the NERC Rules of Procedure, NERC provided the initial draft to Commission's Office of Electric Reliability on January 8, 2018. NERC expects to post the draft request for a 45-day public comment period on or around January 30, 2018. Following the close of this comment period, NERC will review the comments received and revise the draft Section 1600 GMD Data Request as appropriate. NERC will also continue work to develop the necessary information technology infrastructure and data reporting specifications to facilitate the collection of GMD data. NERC intends to seek authorization from the NERC Board of Trustees to issue the Section 1600 GMD Data Request in August 2018.

---

<sup>47</sup> *Order on GMD Research Work Plan*, 161 FERC ¶ 61,048 (Oct. 19, 2017) (accepting NERC's preliminary GMD Research Work Plan).

## VII. CONCLUSION

For the reasons set forth above, NERC respectfully requests that the Commission approve proposed Reliability Standard TPL-007-2 and related elements, the proposed implementation plan, and the retirement of currently-effective Reliability Standard TPL-007-1 as discussed herein.

Respectfully submitted,

/s/ Lauren A. Perotti

Shamai Elstein  
Senior Counsel  
Lauren A. Perotti  
Counsel  
Candice Castaneda  
Counsel  
North American Electric Reliability  
Corporation  
1325 G Street, N.W., Suite 600  
Washington, D.C. 20005  
(202) 400-3000  
(202) 644-8099 – facsimile  
shamai.elstein@nerc.net  
lauren.perotti@nerc.net  
candice.castaneda@nerc.net

*Counsel for the North American Electric  
Reliability Corporation*

Date: January 22, 2018

**Exhibit A**

**Proposed Reliability Standard TPL-007-2 – Transmission System Planned Performance for  
Geomagnetic Disturbance Operations**



**Proposed Reliability Standard TPL-007-2 – Transmission System Planned Performance for  
Geomagnetic Disturbance Operations - Clean**

## A. Introduction

1. **Title:** Transmission System Planned Performance for Geomagnetic Disturbance Events
2. **Number:** TPL-007-2
3. **Purpose:** Establish requirements for Transmission system planned performance during geomagnetic disturbance (GMD) events.
4. **Applicability:**
  - 4.1. **Functional Entities:**
    - 4.1.1. Planning Coordinator with a planning area that includes a Facility or Facilities specified in 4.2;
    - 4.1.2. Transmission Planner with a planning area that includes a Facility or Facilities specified in 4.2;
    - 4.1.3. Transmission Owner who owns a Facility or Facilities specified in 4.2; and
    - 4.1.4. Generator Owner who owns a Facility or Facilities specified in 4.2.
  - 4.2. **Facilities:**
    - 4.2.1. Facilities that include power transformer(s) with a high side, wye-grounded winding with terminal voltage greater than 200 kV.
5. **Effective Date:** See Implementation Plan for TPL-007-2.
6. **Background:** During a GMD event, geomagnetically-induced currents (GIC) may cause transformer hot-spot heating or damage, loss of Reactive Power sources, increased Reactive Power demand, and Misoperation(s), the combination of which may result in voltage collapse and blackout

## B. Requirements and Measures

- R1. Each Planning Coordinator, in conjunction with its Transmission Planner(s), shall identify the individual and joint responsibilities of the Planning Coordinator and Transmission Planner(s) in the Planning Coordinator's planning area for maintaining models, performing the study or studies needed to complete benchmark and supplemental GMD Vulnerability Assessments, and implementing process(es) to obtain GMD measurement data as specified in this standard. [*Violation Risk Factor: Lower*] [*Time Horizon: Long-term Planning*]

- M1.** Each Planning Coordinator, in conjunction with its Transmission Planners, shall provide documentation on roles and responsibilities, such as meeting minutes, agreements, copies of procedures or protocols in effect between entities or between departments of a vertically integrated system, or email correspondence that identifies an agreement has been reached on individual and joint responsibilities for maintaining models, performing the study or studies needed to complete benchmark and supplemental GMD Vulnerability Assessments, and implementing process(es) to obtain GMD measurement data in accordance with Requirement R1.
- R2.** Each responsible entity, as determined in Requirement R1, shall maintain System models and GIC System models of the responsible entity’s planning area for performing the study or studies needed to complete benchmark and supplemental GMD Vulnerability Assessments. *[Violation Risk Factor: High] [Time Horizon: Long-term Planning]*
- M2.** Each responsible entity, as determined in Requirement R1, shall have evidence in either electronic or hard copy format that it is maintaining System models and GIC System models of the responsible entity’s planning area for performing the study or studies needed to complete benchmark and supplemental GMD Vulnerability Assessments.
- R3.** Each responsible entity, as determined in Requirement R1, shall have criteria for acceptable System steady state voltage performance for its System during the GMD events described in Attachment 1. *[Violation Risk Factor: Medium] [Time Horizon: Long-term Planning]*
- M3.** Each responsible entity, as determined in Requirement R1, shall have evidence, such as electronic or hard copies of the criteria for acceptable System steady state voltage performance for its System in accordance with Requirement R3.

**Benchmark GMD Vulnerability Assessment(s)**

- R4.** Each responsible entity, as determined in Requirement R1, shall complete a benchmark GMD Vulnerability Assessment of the Near-Term Transmission Planning Horizon at least once every 60 calendar months. This benchmark GMD Vulnerability Assessment shall use a study or studies based on models identified in Requirement R2, document assumptions, and document summarized results of the steady state analysis. *[Violation Risk Factor: High] [Time Horizon: Long-term Planning]*
  - 4.1.** The study or studies shall include the following conditions:
    - 4.1.1.** System On-Peak Load for at least one year within the Near-Term Transmission Planning Horizon; and
    - 4.1.2.** System Off-Peak Load for at least one year within the Near-Term Transmission Planning Horizon.

- 4.2.** The study or studies shall be conducted based on the benchmark GMD event described in Attachment 1 to determine whether the System meets the performance requirements for the steady state planning benchmark GMD event contained in Table 1.
- 4.3.** The benchmark GMD Vulnerability Assessment shall be provided: (i) to the responsible entity's Reliability Coordinator, adjacent Planning Coordinators, and adjacent Transmission Planners within 90 calendar days of completion, and (ii) to any functional entity that submits a written request and has a reliability-related need within 90 calendar days of receipt of such request or within 90 calendar days of completion of the benchmark GMD Vulnerability Assessment, whichever is later.
- 4.3.1.** If a recipient of the benchmark GMD Vulnerability Assessment provides documented comments on the results, the responsible entity shall provide a documented response to that recipient within 90 calendar days of receipt of those comments.
- M4.** Each responsible entity, as determined in Requirement R1, shall have dated evidence such as electronic or hard copies of its benchmark GMD Vulnerability Assessment meeting all of the requirements in Requirement R4. Each responsible entity, as determined in Requirement R1, shall also provide evidence, such as email records, web postings with an electronic notice of posting, or postal receipts showing recipient and date, that it has distributed its benchmark GMD Vulnerability Assessment: (i) to the responsible entity's Reliability Coordinator, adjacent Planning Coordinators, and adjacent Transmission Planners within 90 calendar days of completion, and (ii) to any functional entity that submits a written request and has a reliability-related need within 90 calendar days of receipt of such request or within 90 calendar days of completion of the benchmark GMD Vulnerability Assessment, whichever is later, as specified in Requirement R4. Each responsible entity, as determined in Requirement R1, shall also provide evidence, such as email notices or postal receipts showing recipient and date, that it has provided a documented response to comments received on its benchmark GMD Vulnerability Assessment within 90 calendar days of receipt of those comments in accordance with Requirement R4.
- R5.** Each responsible entity, as determined in Requirement R1, shall provide GIC flow information to be used for the benchmark thermal impact assessment of transformers specified in Requirement R6 to each Transmission Owner and Generator Owner that owns an applicable Bulk Electric System (BES) power transformer in the planning area. The GIC flow information shall include: *[Violation Risk Factor: Medium] [Time Horizon: Long-term Planning]*
- 5.1.** The maximum effective GIC value for the worst case geoelectric field orientation for the benchmark GMD event described in Attachment 1. This value shall be provided to the Transmission Owner or Generator Owner that owns each applicable BES power transformer in the planning area.

- 5.2.** The effective GIC time series, GIC(t), calculated using the benchmark GMD event described in Attachment 1 in response to a written request from the Transmission Owner or Generator Owner that owns an applicable BES power transformer in the planning area. GIC(t) shall be provided within 90 calendar days of receipt of the written request and after determination of the maximum effective GIC value in Part 5.1.
- M5.** Each responsible entity, as determined in Requirement R1, shall provide evidence, such as email records, web postings with an electronic notice of posting, or postal receipts showing recipient and date, that it has provided the maximum effective GIC values to the Transmission Owner and Generator Owner that owns each applicable BES power transformer in the planning area as specified in Requirement R5, Part 5.1. Each responsible entity, as determined in Requirement R1, shall also provide evidence, such as email records, web postings with an electronic notice of posting, or postal receipts showing recipient and date, that it has provided GIC(t) in response to a written request from the Transmission Owner or Generator Owner that owns an applicable BES power transformer in the planning area.
- R6.** Each Transmission Owner and Generator Owner shall conduct a benchmark thermal impact assessment for its solely and jointly owned applicable BES power transformers where the maximum effective GIC value provided in Requirement R5, Part 5.1, is 75 A per phase or greater. The benchmark thermal impact assessment shall: *[Violation Risk Factor: Medium] [Time Horizon: Long-term Planning]*
- 6.1.** Be based on the effective GIC flow information provided in Requirement R5;
- 6.2.** Document assumptions used in the analysis;
- 6.3.** Describe suggested actions and supporting analysis to mitigate the impact of GICs, if any; and
- 6.4.** Be performed and provided to the responsible entities, as determined in Requirement R1, within 24 calendar months of receiving GIC flow information specified in Requirement R5, Part 5.1.
- M6.** Each Transmission Owner and Generator Owner shall have evidence such as electronic or hard copies of its benchmark thermal impact assessment for all of its solely and jointly owned applicable BES power transformers where the maximum effective GIC value provided in Requirement R5, Part 5.1, is 75 A per phase or greater, and shall have evidence such as email records, web postings with an electronic notice of posting, or postal receipts showing recipient and date, that it has provided its thermal impact assessment to the responsible entities as specified in Requirement R6.

- R7.** Each responsible entity, as determined in Requirement R1, that concludes through the benchmark GMD Vulnerability Assessment conducted in Requirement R4 that their System does not meet the performance requirements for the steady state planning benchmark GMD event contained in Table 1, shall develop a Corrective Action Plan (CAP) addressing how the performance requirements will be met. The CAP shall:  
*[Violation Risk Factor: High] [Time Horizon: Long-term Planning]*
- 7.1.** List System deficiencies and the associated actions needed to achieve required System performance. Examples of such actions include:
- Installation, modification, retirement, or removal of Transmission and generation Facilities and any associated equipment.
  - Installation, modification, or removal of Protection Systems or Remedial Action Schemes.
  - Use of Operating Procedures, specifying how long they will be needed as part of the CAP.
  - Use of Demand-Side Management, new technologies, or other initiatives.
- 7.2.** Be developed within one year of completion of the benchmark GMD Vulnerability Assessment.
- 7.3.** Include a timetable, subject to revision by the responsible entity in Part 7.4, for implementing the selected actions from Part 7.1. The timetable shall:
- 7.3.1.** Specify implementation of non-hardware mitigation, if any, within two years of development of the CAP; and
- 7.3.2.** Specify implementation of hardware mitigation, if any, within four years of development of the CAP.
- 7.4.** Be revised if situations beyond the control of the responsible entity determined in Requirement R1 prevent implementation of the CAP within the timetable for implementation provided in Part 7.3. The revised CAP shall document the following, and be updated at least once every 12 calendar months until implemented:
- 7.4.1.** Circumstances causing the delay for fully or partially implementing the selected actions in Part 7.1;
- 7.4.2.** Description of the original CAP, and any previous changes to the CAP, with the associated timetable(s) for implementing the selected actions in Part 7.1; and
- 7.4.3.** Revisions to the selected actions in Part 7.1, if any, including utilization of Operating Procedures if applicable, and the updated timetable for implementing the selected actions.

- 7.5.** Be provided: (i) to the responsible entity’s Reliability Coordinator, adjacent Planning Coordinator(s), adjacent Transmission Planner(s), and functional entities referenced in the CAP within 90 calendar days of development or revision, and (ii) to any functional entity that submits a written request and has a reliability-related need within 90 calendar days of receipt of such request or within 90 calendar days of development or revision, whichever is later.
- 7.5.1.** If a recipient of the CAP provides documented comments on the results, the responsible entity shall provide a documented response to that recipient within 90 calendar days of receipt of those comments.
- M7.** Each responsible entity, as determined in Requirement R1, that concludes, through the benchmark GMD Vulnerability Assessment conducted in Requirement R4, that the responsible entity’s System does not meet the performance requirements for the steady state planning benchmark GMD event contained in Table 1 shall have evidence such as dated electronic or hard copies of its CAP including timetable for implementing selected actions, as specified in Requirement R7. Each responsible entity, as determined in Requirement R1, shall also provide evidence, such as email records or postal receipts showing recipient and date, that it has revised its CAP if situations beyond the responsible entity's control prevent implementation of the CAP within the timetable specified. Each responsible entity, as determined in Requirement R1, shall also provide evidence, such as email records, web postings with an electronic notice of posting, or postal receipts showing recipient and date, that it has distributed its CAP or relevant information, if any, (i) to the responsible entity’s Reliability Coordinator, adjacent Planning Coordinator(s), adjacent Transmission Planner(s), and functional entities referenced in the CAP within 90 calendar days of development or revision, and (ii) to any functional entity that submits a written request and has a reliability-related need within 90 calendar days of receipt of such request or within 90 calendar days of development or revision, whichever is later as specified in Requirement R7. Each responsible entity, as determined in Requirement R1, shall also provide evidence, such as email notices or postal receipts showing recipient and date, that it has provided a documented response to comments received on its CAP within 90 calendar days of receipt of those comments, in accordance with Requirement R7.

**Supplemental GMD Vulnerability Assessment(s)**

- R8.** Each responsible entity, as determined in Requirement R1, shall complete a supplemental GMD Vulnerability Assessment of the Near-Term Transmission Planning Horizon at least once every 60 calendar months. This supplemental GMD Vulnerability Assessment shall use a study or studies based on models identified in Requirement R2, document assumptions, and document summarized results of the steady state analysis. *[Violation Risk Factor: High] [Time Horizon: Long-term Planning]*
- 8.1.** The study or studies shall include the following conditions:
- 8.1.1.** System On-Peak Load for at least one year within the Near-Term Transmission Planning Horizon; and





- R9.** Each responsible entity, as determined in Requirement R1, shall provide GIC flow information to be used for the supplemental thermal impact assessment of transformers specified in Requirement R10 to each Transmission Owner and Generator Owner that owns an applicable Bulk Electric System (BES) power transformer in the planning area. The GIC flow information shall include: *[Violation Risk Factor: Medium] [Time Horizon: Long-term Planning]*
- 9.1.** The maximum effective GIC value for the worst case geoelectric field orientation for the supplemental GMD event described in Attachment 1. This value shall be provided to the Transmission Owner or Generator Owner that owns each applicable BES power transformer in the planning area.
- 9.2.** The effective GIC time series, GIC(t), calculated using the supplemental GMD event described in Attachment 1 in response to a written request from the Transmission Owner or Generator Owner that owns an applicable BES power transformer in the planning area. GIC(t) shall be provided within 90 calendar days of receipt of the written request and after determination of the maximum effective GIC value in Part 9.1.
- M9.** Each responsible entity, as determined in Requirement R1, shall provide evidence, such as email records, web postings with an electronic notice of posting, or postal receipts showing recipient and date, that it has provided the maximum effective GIC values to the Transmission Owner and Generator Owner that owns each applicable BES power transformer in the planning area as specified in Requirement R9, Part 9.1. Each responsible entity, as determined in Requirement R1, shall also provide evidence, such as email records, web postings with an electronic notice of posting, or postal receipts showing recipient and date, that it has provided GIC(t) in response to a written request from the Transmission Owner or Generator Owner that owns an applicable BES power transformer in the planning area.
- R10.** Each Transmission Owner and Generator Owner shall conduct a supplemental thermal impact assessment for its solely and jointly owned applicable BES power transformers where the maximum effective GIC value provided in Requirement R9, Part 9.1, is 85 A per phase or greater. The supplemental thermal impact assessment shall: *[Violation Risk Factor: Medium] [Time Horizon: Long-term Planning]*
- 10.1.** Be based on the effective GIC flow information provided in Requirement R9;
- 10.2.** Document assumptions used in the analysis;
- 10.3.** Describe suggested actions and supporting analysis to mitigate the impact of GICs, if any; and
- 10.4.** Be performed and provided to the responsible entities, as determined in Requirement R1, within 24 calendar months of receiving GIC flow information specified in Requirement R9, Part 9.1.

**M10.** Each Transmission Owner and Generator Owner shall have evidence such as electronic or hard copies of its supplemental thermal impact assessment for all of its solely and jointly owned applicable BES power transformers where the maximum effective GIC value provided in Requirement R9, Part 9.1, is 85 A per phase or greater, and shall have evidence such as email records, web postings with an electronic notice of posting, or postal receipts showing recipient and date, that it has provided its supplemental thermal impact assessment to the responsible entities as specified in Requirement R10.

### **GMD Measurement Data Processes**

**R11.** Each responsible entity, as determined in Requirement R1, shall implement a process to obtain GIC monitor data from at least one GIC monitor located in the Planning Coordinator's planning area or other part of the system included in the Planning Coordinator's GIC System model. *[Violation Risk Factor: Lower] [Time Horizon: Long-term Planning]*

**M11.** Each responsible entity, as determined in Requirement R1, shall have evidence such as electronic or hard copies of its GIC monitor location(s) and documentation of its process to obtain GIC monitor data in accordance with Requirement R11.

**R12.** Each responsible entity, as determined in Requirement R1, shall implement a process to obtain geomagnetic field data for its Planning Coordinator's planning area. *[Violation Risk Factor: Lower] [Time Horizon: Long-term Planning]*

**M12.** Each responsible entity, as determined in Requirement R1, shall have evidence such as electronic or hard copies of its process to obtain geomagnetic field data for its Planning Coordinator's planning area in accordance with Requirement R12.

## **C. Compliance**

### **1. Compliance Monitoring Process**

**1.1. Compliance Enforcement Authority:** "Compliance Enforcement Authority" means NERC or the Regional Entity, or any entity as otherwise designated by an Applicable Governmental Authority, in their respective roles of monitoring and/or enforcing compliance with mandatory and enforceable Reliability Standards in their respective jurisdictions.

**1.2. Evidence Retention:** The following evidence retention period(s) identify the period of time an entity is required to retain specific evidence to demonstrate compliance. For instances where the evidence retention period specified below is shorter than the time since the last audit, the Compliance Enforcement Authority may ask an entity to provide other evidence to show that it was compliant for the full-time period since the last audit.

The applicable entity shall keep data or evidence to show compliance as identified below unless directed by its Compliance Enforcement Authority to retain specific evidence for a longer period of time as part of an investigation.

- For Requirements R1, R2, R3, R5, R6, R9, and R10, each responsible entity shall retain documentation as evidence for five years.
- For Requirements R4 and R8, each responsible entity shall retain documentation of the current GMD Vulnerability Assessment and the preceding GMD Vulnerability Assessment.
- For Requirement R7, each responsible entity shall retain documentation as evidence for five years or until all actions in the Corrective Action Plan are completed, whichever is later.
- For Requirements R11 and R12, each responsible entity shall retain documentation as evidence for three years.

**1.3. Compliance Monitoring and Enforcement Program:** As defined in the NERC Rules of Procedure, “Compliance Monitoring and Enforcement Program” refers to the identification of the processes that will be used to evaluate data or information for the purpose of assessing performance or outcomes with the associated Reliability Standard.

**Table 1: Steady State Planning GMD Event**

**Steady State:**

- a. Voltage collapse, Cascading and uncontrolled islanding shall not occur.
- b. Generation loss is acceptable as a consequence of the steady state planning GMD events.
- c. Planned System adjustments such as Transmission configuration changes and re-dispatch of generation are allowed if such adjustments are executable within the time duration applicable to the Facility Ratings.

Category	Initial Condition	Event	Interruption of Firm Transmission Service Allowed	Load Loss Allowed
<b>Benchmark GMD Event - GMD Event with Outages</b>	1. System as may be postured in response to space weather information <sup>1</sup> , and then 2. GMD event <sup>2</sup>	Reactive Power compensation devices and other Transmission Facilities removed as a result of Protection System operation or Misoperation due to harmonics during the GMD event	Yes <sup>3</sup>	Yes <sup>3</sup>
<b>Supplemental GMD Event - GMD Event with Outages</b>	1. System as may be postured in response to space weather information <sup>1</sup> , and then 2. GMD event <sup>2</sup>	Reactive Power compensation devices and other Transmission Facilities removed as a result of Protection System operation or Misoperation due to harmonics during the GMD event	Yes	Yes

**Table 1: Steady State Performance Footnotes**

1. The System condition for GMD planning may include adjustments to posture the System that are executable in response to space weather information.
2. The GMD conditions for the benchmark and supplemental planning events are described in Attachment 1.
3. Load loss as a result of manual or automatic Load shedding (e.g., UVLS) and/or curtailment of Firm Transmission Service may be used to meet BES performance requirements during studied GMD conditions. The likelihood and magnitude of Load loss or curtailment of Firm Transmission Service should be minimized.

### Violation Severity Levels

R #	Violation Severity Levels			
	Lower VSL	Moderate VSL	High VSL	Severe VSL
R1.	N/A	N/A	N/A	The Planning Coordinator, in conjunction with its Transmission Planner(s), failed to determine and identify individual or joint responsibilities of the Planning Coordinator and Transmission Planner(s) in the Planning Coordinator’s planning area for maintaining models, performing the study or studies needed to complete benchmark and supplemental GMD Vulnerability Assessments, and implementing process(es) to obtain GMD measurement data as specified in this standard.
R2.	N/A	N/A	The responsible entity did not maintain either System models or GIC System models of the responsible entity’s planning area for performing the studies	The responsible entity did not maintain both System models and GIC System models of the responsible entity’s planning area for performing the studies

R #	Violation Severity Levels			
	Lower VSL	Moderate VSL	High VSL	Severe VSL
			needed to complete benchmark and supplemental GMD Vulnerability Assessments.	needed to complete benchmark and supplemental GMD Vulnerability Assessments.
<b>R3.</b>	N/A	N/A	N/A	The responsible entity did not have criteria for acceptable System steady state voltage performance for its System during the GMD events described in Attachment 1 as required.
<b>R4.</b>	The responsible entity completed a benchmark GMD Vulnerability Assessment, but it was more than 60 calendar months and less than or equal to 64 calendar months since the last benchmark GMD Vulnerability Assessment.	The responsible entity's completed benchmark GMD Vulnerability Assessment failed to satisfy one of the elements listed in Requirement R4, Parts 4.1 through 4.3; OR The responsible entity completed a benchmark GMD Vulnerability Assessment, but it was more than 64 calendar months and less than or equal to 68 calendar months since the	The responsible entity's completed benchmark GMD Vulnerability Assessment failed to satisfy two of the elements listed in Requirement R4, Parts 4.1 through 4.3; OR The responsible entity completed a benchmark GMD Vulnerability Assessment, but it was more than 68 calendar months and less than or equal to 72 calendar months since the	The responsible entity's completed benchmark GMD Vulnerability Assessment failed to satisfy three of the elements listed in Requirement R4, Parts 4.1 through 4.3; OR The responsible entity completed a benchmark GMD Vulnerability Assessment, but it was more than 72 calendar months since the last benchmark

R #	Violation Severity Levels			
	Lower VSL	Moderate VSL	High VSL	Severe VSL
		last benchmark GMD Vulnerability Assessment.	last benchmark GMD Vulnerability Assessment.	GMD Vulnerability Assessment; OR The responsible entity does not have a completed benchmark GMD Vulnerability Assessment.
R5.	The responsible entity provided the effective GIC time series, GIC(t), in response to written request, but did so more than 90 calendar days and less than or equal to 100 calendar days after receipt of a written request.	The responsible entity provided the effective GIC time series, GIC(t), in response to written request, but did so more than 100 calendar days and less than or equal to 110 calendar days after receipt of a written request.	The responsible entity provided the effective GIC time series, GIC(t), in response to written request, but did so more than 110 calendar days after receipt of a written request.	The responsible entity did not provide the maximum effective GIC value to the Transmission Owner and Generator Owner that owns each applicable BES power transformer in the planning area; OR The responsible entity did not provide the effective GIC time series, GIC(t), upon written request.
R6.	The responsible entity failed to conduct a benchmark thermal impact assessment for 5% or less or one of its solely owned and jointly owned applicable BES power	The responsible entity failed to conduct a benchmark thermal impact assessment for more than 5% up to (and including) 10% or two of its solely owned and jointly	The responsible entity failed to conduct a benchmark thermal impact assessment for more than 10% up to (and including) 15% or three of its solely owned and	The responsible entity failed to conduct a benchmark thermal impact assessment for more than 15% or more than three of its solely owned and jointly owned

R #	Violation Severity Levels			
	Lower VSL	Moderate VSL	High VSL	Severe VSL
	<p>transformers (whichever is greater) where the maximum effective GIC value provided in Requirement R5, Part 5.1, is 75 A or greater per phase; OR The responsible entity conducted a benchmark thermal impact assessment for its solely owned and jointly owned applicable BES power transformers where the maximum effective GIC value provided in Requirement R5, Part 5.1, is 75 A or greater per phase but did so more than 24 calendar months and less than or equal to 26 calendar months of receiving GIC flow information specified in Requirement R5, Part 5.1.</p>	<p>owned applicable BES power transformers (whichever is greater) where the maximum effective GIC value provided in Requirement R5, Part 5.1, is 75 A or greater per phase; OR The responsible entity conducted a benchmark thermal impact assessment for its solely owned and jointly owned applicable BES power transformers where the maximum effective GIC value provided in Requirement R5, Part 5.1, is 75 A or greater per phase but did so more than 26 calendar months and less than or equal to 28 calendar months of receiving GIC flow information specified in Requirement R5, Part 5.1; OR The responsible entity failed to include one of the</p>	<p>jointly owned applicable BES power transformers (whichever is greater) where the maximum effective GIC value provided in Requirement R5, Part 5.1, is 75 A or greater per phase; OR The responsible entity conducted a benchmark thermal impact assessment for its solely owned and jointly owned applicable BES power transformers where the maximum effective GIC value provided in Requirement R5, Part 5.1, is 75 A or greater per phase but did so more than 28 calendar months and less than or equal to 30 calendar months of receiving GIC flow information specified in Requirement R5, Part 5.1; OR The responsible entity failed to include two of the</p>	<p>applicable BES power transformers (whichever is greater) where the maximum effective GIC value provided in Requirement R5, Part 5.1, is 75 A or greater per phase; OR The responsible entity conducted a benchmark thermal impact assessment for its solely owned and jointly owned applicable BES power transformers where the maximum effective GIC value provided in Requirement R5, Part 5.1, is 75 A or greater per phase but did so more than 30 calendar months of receiving GIC flow information specified in Requirement R5, Part 5.1; OR The responsible entity failed to include three of the required elements as listed</p>



R #	Violation Severity Levels			
	Lower VSL	Moderate VSL	High VSL	Severe VSL
		required elements as listed in Requirement R6, Parts 6.1 through 6.3.	required elements as listed in Requirement R6, Parts 6.1 through 6.3.	in Requirement R6, Parts 6.1 through 6.3.
<b>R7.</b>	The responsible entity's Corrective Action Plan failed to comply with one of the elements in Requirement R7, Parts 7.1 through 7.5.	The responsible entity's Corrective Action Plan failed to comply with two of the elements in Requirement R7, Parts 7.1 through 7.5.	The responsible entity's Corrective Action Plan failed to comply with three of the elements in Requirement R7, Parts 7.1 through 7.5.	The responsible entity's Corrective Action Plan failed to comply with four or more of the elements in Requirement R7, Parts 7.1 through 7.5; OR The responsible entity did not have a Corrective Action Plan as required by Requirement R7.
<b>R8.</b>	The responsible entity's completed supplemental GMD Vulnerability Assessment failed to satisfy one of elements listed in Requirement R8, Parts 8.1 through 8.4; OR The responsible entity completed a supplemental GMD Vulnerability Assessment, but it was more	The responsible entity's completed supplemental GMD Vulnerability Assessment failed to satisfy two of elements listed in Requirement R8, Parts 8.1 through 8.4; OR The responsible entity completed a supplemental GMD Vulnerability Assessment, but it was more	The responsible entity's completed supplemental GMD Vulnerability Assessment failed to satisfy three of the elements listed in Requirement R8, Parts 8.1 through 8.4; OR The responsible entity completed a supplemental GMD Vulnerability Assessment, but it was more	The responsible entity's completed supplemental GMD Vulnerability Assessment failed to satisfy four of the elements listed in Requirement R8, Parts 8.1 through 8.4; OR The responsible entity completed a supplemental GMD Vulnerability Assessment, but it was more

R #	Violation Severity Levels			
	Lower VSL	Moderate VSL	High VSL	Severe VSL
	than 60 calendar months and less than or equal to 64 calendar months since the last supplemental GMD Vulnerability Assessment.	than 64 calendar months and less than or equal to 68 calendar months since the last supplemental GMD Vulnerability Assessment.	than 68 calendar months and less than or equal to 72 calendar months since the last supplemental GMD Vulnerability Assessment.	than 72 calendar months since the last supplemental GMD Vulnerability Assessment; OR The responsible entity does not have a completed supplemental GMD Vulnerability Assessment.
R9.	The responsible entity provided the effective GIC time series, GIC(t), in response to written request, but did so more than 90 calendar days and less than or equal to 100 calendar days after receipt of a written request.	The responsible entity provided the effective GIC time series, GIC(t), in response to written request, but did so more than 100 calendar days and less than or equal to 110 calendar days after receipt of a written request.	The responsible entity provided the effective GIC time series, GIC(t), in response to written request, but did so more than 110 calendar days after receipt of a written request.	The responsible entity did not provide the maximum effective GIC value to the Transmission Owner and Generator Owner that owns each applicable BES power transformer in the planning area; OR The responsible entity did not provide the effective GIC time series, GIC(t), upon written request.
R10.	The responsible entity failed to conduct a supplemental thermal impact assessment for 5% or less or one of its	The responsible entity failed to conduct a supplemental thermal impact assessment for more than 5% up to (and	The responsible entity failed to conduct a supplemental thermal impact assessment for more than 10% up to	The responsible entity failed to conduct a supplemental thermal impact assessment for more than 15% or more

R #	Violation Severity Levels			
	Lower VSL	Moderate VSL	High VSL	Severe VSL
	<p>solely owned and jointly owned applicable BES power transformers (whichever is greater) where the maximum effective GIC value provided in Requirement R9, Part 9.1, is 85 A or greater per phase;</p> <p>OR</p> <p>The responsible entity conducted a supplemental thermal impact assessment for its solely owned and jointly owned applicable BES power transformers where the maximum effective GIC value provided in Requirement R9, Part 9.1, is 85 A or greater per phase but did so more than 24 calendar months and less than or equal to 26 calendar months of receiving GIC flow information specified in Requirement R9, Part 9.1.</p>	<p>including) 10% or two of its solely owned and jointly owned applicable BES power transformers (whichever is greater) where the maximum effective GIC value provided in Requirement R9, Part 9.1, is 85 A or greater per phase;</p> <p>OR</p> <p>The responsible entity conducted a supplemental thermal impact assessment for its solely owned and jointly owned applicable BES power transformers where the maximum effective GIC value provided in Requirement R9, Part 9.1, is 85 A or greater per phase but did so more than 26 calendar months and less than or equal to 28 calendar months of receiving GIC flow information specified in Requirement R9, Part 9.1</p> <p>OR</p>	<p>(and including) 15% or three of its solely owned and jointly owned applicable BES power transformers (whichever is greater) where the maximum effective GIC value provided in Requirement R9, Part 9.1, is 85 A or greater per phase;</p> <p>OR</p> <p>The responsible entity conducted a supplemental thermal impact assessment for its solely owned and jointly owned applicable BES power transformers where the maximum effective GIC value provided in Requirement R9, Part 9.1, is 85 A or greater per phase but did so more than 28 calendar months and less than or equal to 30 calendar months of receiving GIC flow information specified in Requirement R9, Part 9.1;</p> <p>OR</p>	<p>than three of its solely owned and jointly owned applicable BES power transformers (whichever is greater) where the maximum effective GIC value provided in Requirement R9, Part 9.1, is 85 A or greater per phase;</p> <p>OR</p> <p>The responsible entity conducted a supplemental thermal impact assessment for its solely owned and jointly owned applicable BES power transformers where the maximum effective GIC value provided in Requirement R9, Part 9.1, is 85 A or greater per phase but did so more than 30 calendar months of receiving GIC flow information specified in Requirement R9, Part 9.1;</p> <p>OR</p>

R #	Violation Severity Levels			
	Lower VSL	Moderate VSL	High VSL	Severe VSL
		The responsible entity failed to include one of the required elements as listed in Requirement R10, Parts 10.1 through 10.3.	The responsible entity failed to include two of the required elements as listed in Requirement R10, Parts 10.1 through 10.3.	The responsible entity failed to include three of the required elements as listed in Requirement R10, Parts 10.1 through 10.3.
<b>R11.</b>	N/A	N/A	N/A	The responsible entity did not implement a process to obtain GIC monitor data from at least one GIC monitor located in the Planning Coordinator’s planning area or other part of the system included in the Planning Coordinator’s GIC System Model.
<b>R12.</b>	N/A	N/A	N/A	The responsible entity did not implement a process to obtain geomagnetic field data for its Planning Coordinator’s planning area.

**D. Regional Variances**

None.

**E. Associated Documents**

Attachment 1

## Version History

Version	Date	Action	Change Tracking
1	December 17, 2014	Adopted by the NERC Board of Trustees	New
2	November 9, 2017	Adopted by the NERC Board of Trustees	Revised to respond to directives in FERC Order No. 830.

## Attachment 1

### Calculating Geoelectric Fields for the Benchmark and Supplemental GMD Events

The benchmark GMD event<sup>1</sup> defines the geoelectric field values used to compute GIC flows that are needed to conduct a benchmark GMD Vulnerability Assessment. It is composed of the following elements: (1) a reference peak geoelectric field amplitude of 8 V/km derived from statistical analysis of historical magnetometer data; (2) scaling factors to account for local geomagnetic latitude; (3) scaling factors to account for local earth conductivity; and (4) a reference geomagnetic field time series or waveform to facilitate time-domain analysis of GMD impact on equipment.

The supplemental GMD event is composed of similar elements as described above, except (1) the reference peak geoelectric field amplitude is 12 V/km over a localized area; and (2) the geomagnetic field time series or waveform includes a local enhancement in the waveform.<sup>2</sup>

The regional geoelectric field peak amplitude used in GMD Vulnerability Assessment,  $E_{peak}$ , can be obtained from the reference geoelectric field value of 8 V/km for the benchmark GMD event (1) or 12 V/km for the supplemental GMD event (2) using the following relationships:

$$E_{peak} = 8 \times \alpha \times \beta_b \text{ (V/km)} \quad (1)$$

$$E_{peak} = 12 \times \alpha \times \beta_s \text{ (V/km)} \quad (2)$$

where,  $\alpha$  is the scaling factor to account for local geomagnetic latitude, and  $\beta$  is a scaling factor to account for the local earth conductivity structure. Subscripts  $b$  and  $s$  for the  $\beta$  scaling factor denote association with the benchmark or supplemental GMD events, respectively.

### Scaling the Geomagnetic Field

The benchmark and supplemental GMD events are defined for geomagnetic latitude of 60° and must be scaled to account for regional differences based on geomagnetic latitude. Table 2 provides a scaling factor correlating peak geoelectric field to geomagnetic latitude. Alternatively, the scaling factor  $\alpha$  is computed with the empirical expression:

$$\alpha = 0.001 \times e^{(0.115 \times L)} \quad (3)$$

where,  $L$  is the geomagnetic latitude in degrees and  $0.1 \leq \alpha \leq 1$ .

<sup>1</sup> The Benchmark Geomagnetic Disturbance Event Description, May 2016 is available on the Related Information webpage for TPL-007-1: [http://www.nerc.com/pa/Stand/TPL0071RD/Benchmark\\_clean\\_May12\\_complete.pdf](http://www.nerc.com/pa/Stand/TPL0071RD/Benchmark_clean_May12_complete.pdf).

<sup>2</sup> The extent of local enhancements is on the order of 100 km in North-South (latitude) direction but longer in East-West (longitude) direction. The local enhancement in the geomagnetic field occurs over the time period of 2-5 minutes. Additional information is available in the Supplemental Geomagnetic Disturbance Event Description, October 2017 white paper on the Project 2013-03 Geomagnetic Disturbance Mitigation project webpage: <http://www.nerc.com/pa/Stand/Pages/Project-2013-03-Geomagnetic-Disturbance-Mitigation.aspx>.

For large planning areas that cover more than one scaling factor from Table 2, the GMD Vulnerability Assessment should be based on a peak geoelectric field that is:

- calculated by using the most conservative (largest) value for  $\alpha$ ; or
- calculated assuming a non-uniform or piecewise uniform geomagnetic field.

<b>Table 2: Geomagnetic Field Scaling Factors for the Benchmark and Supplemental GMD Events</b>	
<b>Geomagnetic Latitude (Degrees)</b>	<b>Scaling Factor1 (<math>\alpha</math>)</b>
≤ 40	0.10
45	0.2
50	0.3
54	0.5
56	0.6
57	0.7
58	0.8
59	0.9
≥ 60	1.0

### Scaling the Geoelectric Field

The benchmark GMD event is defined for the reference Quebec earth model described in Table 4. The peak geoelectric field,  $E_{peak}$ , used in a GMD Vulnerability Assessment may be obtained by either:

- Calculating the geoelectric field for the ground conductivity in the planning area and the reference geomagnetic field time series scaled according to geomagnetic latitude, using a procedure such as the plane wave method described in the NERC GMD Task Force GIC Application Guide;<sup>3</sup> or
- Using the earth conductivity scaling factor  $\beta$  from Table 3 that correlates to the ground conductivity map in Figure 1 or Figure 2. Along with the scaling factor  $\alpha$  from equation (3) or Table 2,  $\beta$  is applied to the reference geoelectric field using equation (1 or 2, as applicable) to obtain the regional geoelectric field peak amplitude  $E_{peak}$  to be used in GMD Vulnerability Assessments. When a ground conductivity model is not available, the planning entity should use the largest  $\beta$  factor of adjacent physiographic regions or a technically justified value.

<sup>3</sup> Available at the NERC GMD Task Force project webpage: [http://www.nerc.com/comm/PC/Pages/Geomagnetic-Disturbance-Task-Force-\(GMDTF\)-2013.aspx](http://www.nerc.com/comm/PC/Pages/Geomagnetic-Disturbance-Task-Force-(GMDTF)-2013.aspx).

The earth models used to calculate Table 3 for the United States were obtained from publicly available information published on the U. S. Geological Survey website.<sup>4</sup> The models used to calculate Table 3 for Canada were obtained from Natural Resources Canada (NRCan) and reflect the average structure for large regions. A planner can also use specific earth model(s) with documented justification and the reference geomagnetic field time series to calculate the  $\beta$  factor(s) as follows:

$$\beta_b = E/8 \text{ for the benchmark GMD event} \quad (4)$$

$$\beta_s = E/12 \text{ for the supplemental GMD} \quad (5)$$

where,  $E$  is the absolute value of peak geoelectric in V/km obtained from the technically justified earth model and the reference geomagnetic field time series.

For large planning areas that span more than one  $\beta$  scaling factor, the most conservative (largest) value for  $\beta$  may be used in determining the peak geoelectric field to obtain conservative results. Alternatively, a planner could perform analysis using a non-uniform or piecewise uniform geoelectric field.

### **Applying the Localized Peak Geoelectric Field in the Supplemental GMD Event**

The peak geoelectric field of the supplemental GMD event occurs in a localized area.<sup>5</sup> Planners have flexibility to determine how to apply the localized peak geoelectric field over the planning area in performing GIC calculations. Examples of approaches are:

- Apply the peak geoelectric field (12 V/km scaled to the planning area) over the entire planning area;
- Apply a spatially limited (12 V/km scaled to the planning area) peak geoelectric field (e.g., 100 km in North-South latitude direction and 500 km in East-West longitude direction) over a portion(s) of the system, and apply the benchmark GMD event over the rest of the system; or
- Other methods to adjust the benchmark GMD event analysis to account for the localized geoelectric field enhancement of the supplemental GMD event.

---

<sup>4</sup> Available at <http://geomag.usgs.gov/conductivity/>.

<sup>5</sup> See the Supplemental Geomagnetic Disturbance Description white paper located on the Project 2013-03 Geomagnetic Disturbance Mitigation project webpage: <http://www.nerc.com/pa/Stand/Pages/Project-2013-03-Geomagnetic-Disturbance-Mitigation.aspx>.



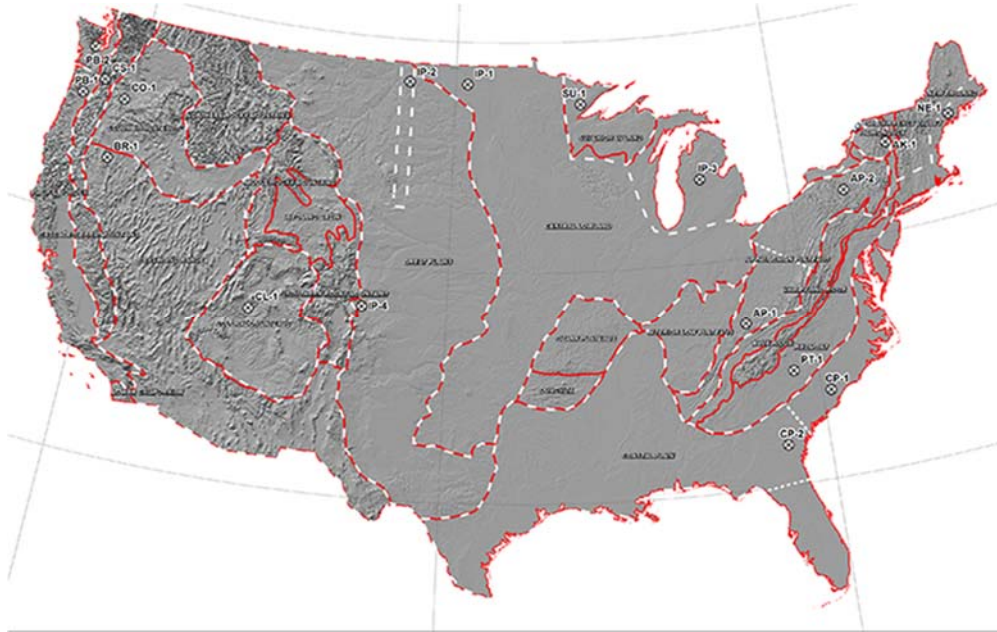


Figure 1: Physiographic Regions of the Continental United States<sup>6</sup>



Figure 2: Physiographic Regions of Canada

<sup>6</sup> Additional map detail is available at the U.S. Geological Survey: <http://geomag.usgs.gov/>.

<b>Table 3: Geoelectric Field Scaling Factors</b>		
<b>Earth model</b>	<b>Scaling Factor Benchmark Event (<math>\beta_b</math>)</b>	<b>Scaling Factor Supplemental Event (<math>\beta_s</math>)</b>
AK1A	0.56	0.51
AK1B	0.56	0.51
AP1	0.33	0.30
AP2	0.82	0.78
BR1	0.22	0.22
CL1	0.76	0.73
CO1	0.27	0.25
CP1	0.81	0.77
CP2	0.95	0.86
FL1	0.76	0.73
CS1	0.41	0.37
IP1	0.94	0.90
IP2	0.28	0.25
IP3	0.93	0.90
IP4	0.41	0.35
NE1	0.81	0.77
PB1	0.62	0.55
PB2	0.46	0.39
PT1	1.17	1.19
SL1	0.53	0.49
SU1	0.93	0.90
BOU	0.28	0.24
FBK	0.56	0.56
PRU	0.21	0.22
BC	0.67	0.62
PRAIRIES	0.96	0.88
SHIELD	1.0	1.0
ATLANTIC	0.79	0.76

**Rationale:** Scaling factors in Table 3 are dependent upon the frequency content of the reference storm. Consequently, the benchmark GMD event and the supplemental GMD event may produce different scaling factors for a given earth model.

The scaling factor associated with the benchmark GMD event for the Florida earth model (FL1) has been updated based on the earth model published on the USGS public website.

<b>Table 4: Reference Earth Model (Quebec)</b>	
<b>Layer Thickness (km)</b>	<b>Resistivity (<math>\Omega</math>-m)</b>
15	20,000
10	200
125	1,000
200	100
$\infty$	3

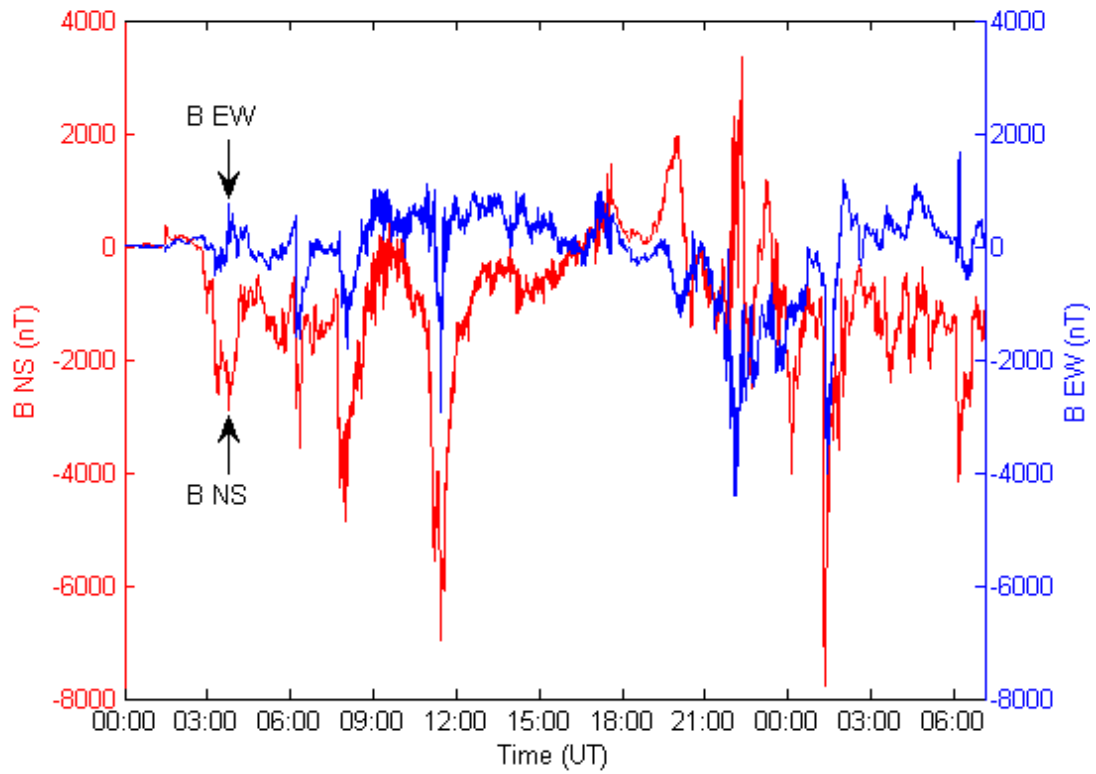
**Reference Geomagnetic Field Time Series or Waveform for the Benchmark GMD Event<sup>7</sup>**

The geomagnetic field measurement record of the March 13-14 1989 GMD event, measured at the NRCan Ottawa geomagnetic observatory, is the basis for the reference geomagnetic field waveform to be used to calculate the GIC time series, GIC(t), required for transformer thermal impact assessment.

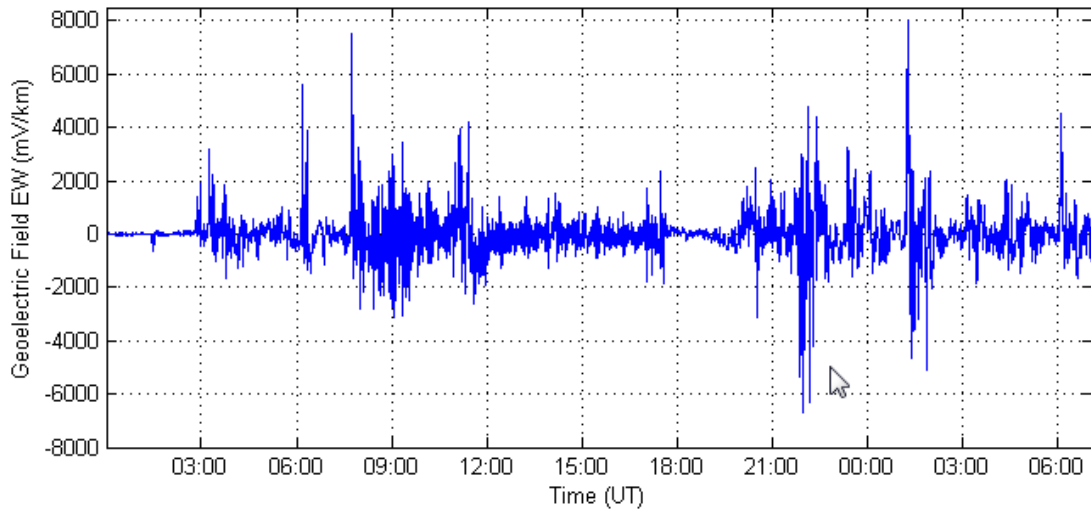
The geomagnetic latitude of the Ottawa geomagnetic observatory is 55°; therefore, the amplitudes of the geomagnetic field measurement data were scaled up to the 60° reference geomagnetic latitude (see Figure 3) such that the resulting peak geoelectric field amplitude computed using the reference earth model was 8 V/km (see Figures 4 and 5). The sampling rate for the geomagnetic field waveform is 10 seconds.<sup>8</sup> To use this geoelectric field time series when a different earth model is applicable, it should be scaled with the appropriate benchmark conductivity scaling factor  $\beta_b$ .

<sup>7</sup> Refer to the Benchmark Geomagnetic Disturbance Event Description white paper for details on the determination of the reference geomagnetic field waveform: <http://www.nerc.com/pa/stand/Pages/TPL0071RI.aspx>.

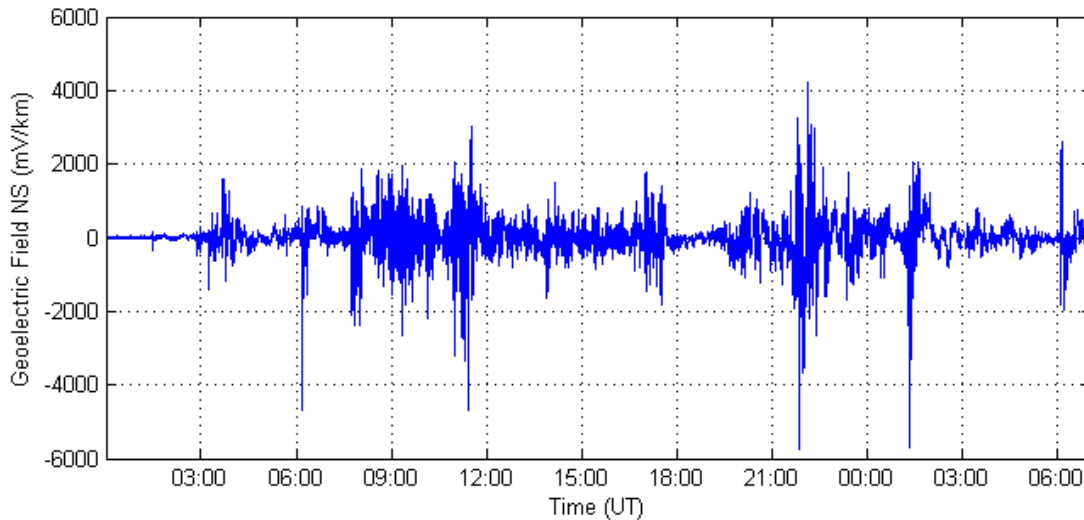
<sup>8</sup> The data file of the benchmark geomagnetic field waveform is available on the Related Information webpage for TPL-007-1: <http://www.nerc.com/pa/stand/Pages/TPL0071RI.aspx>.



**Figure 3: Benchmark Geomagnetic Field Waveform**  
**Red  $B_n$  (Northward), Blue  $B_e$  (Eastward)**



**Figure 4: Benchmark Goelectric Field Waveform**  
 **$E_E$  (Eastward)**



**Figure 5: Benchmark Geoelectric Field Waveform  
 $E_N$  (Northward)**

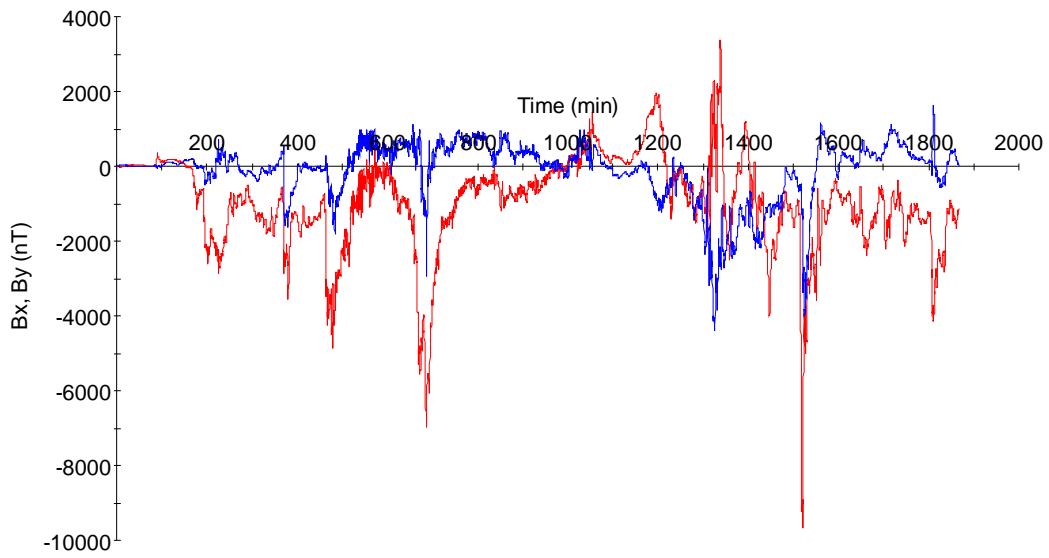
### Reference Geomagnetic Field Time Series or Waveform for the Supplemental GMD Event<sup>9</sup>

The geomagnetic field measurement record of the March 13-14, 1989 GMD event, measured at the NRCan Ottawa geomagnetic observatory, is the basis for the reference geomagnetic field waveform to be used to calculate the GIC time series,  $GIC(t)$ , required for transformer thermal impact assessment for the supplemental GMD event. The supplemental GMD event waveform differs from the benchmark GMD event waveform in that the supplemental GMD event waveform has a local enhancement.

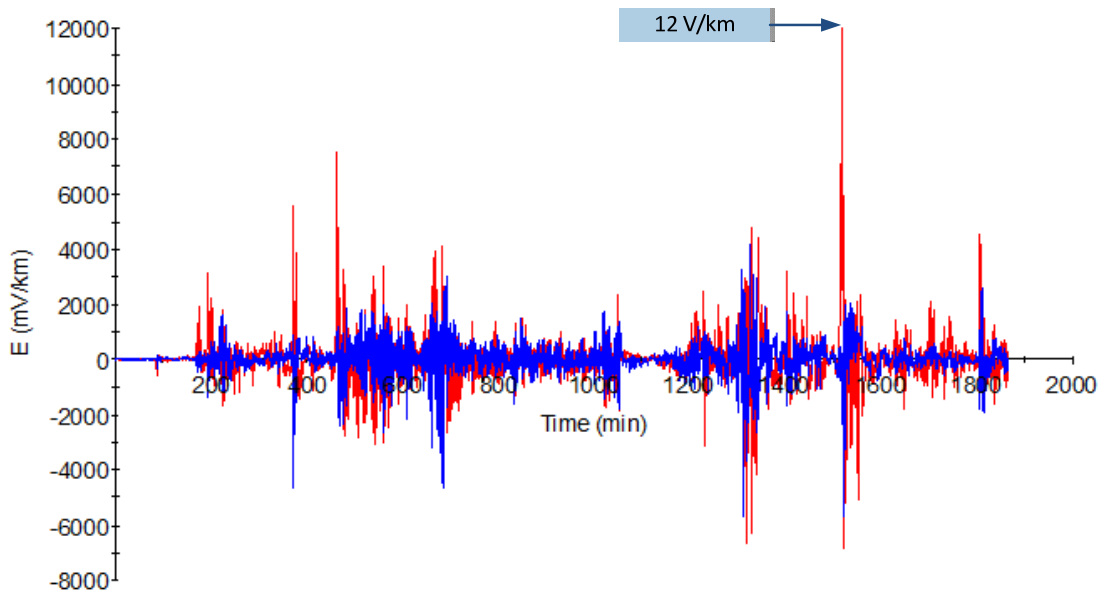
The geomagnetic latitude of the Ottawa geomagnetic observatory is  $55^\circ$ ; therefore, the amplitudes of the geomagnetic field measurement data were scaled up to the  $60^\circ$  reference geomagnetic latitude (see Figure 6) such that the resulting peak geoelectric field amplitude computed using the reference earth model was 12 V/km (see Figure 7). The sampling rate for the geomagnetic field waveform is 10 seconds.<sup>10</sup> To use this geoelectric field time series when a different earth model is applicable, it should be scaled with the appropriate supplemental conductivity scaling factor  $\beta_s$ .

<sup>9</sup> Refer to the Supplemental Geomagnetic Disturbance Event Description white paper for details on the determination of the reference geomagnetic field waveform: <http://www.nerc.com/pa/Stand/Pages/Project-2013-03-Geomagnetic-Disturbance-Mitigation.aspx>.

<sup>10</sup> The data file of the benchmark geomagnetic field waveform is available on the NERC GMD Task Force project webpage: [http://www.nerc.com/comm/PC/Pages/Geomagnetic-Disturbance-Task-Force-\(GMDTF\)-2013.aspx](http://www.nerc.com/comm/PC/Pages/Geomagnetic-Disturbance-Task-Force-(GMDTF)-2013.aspx).



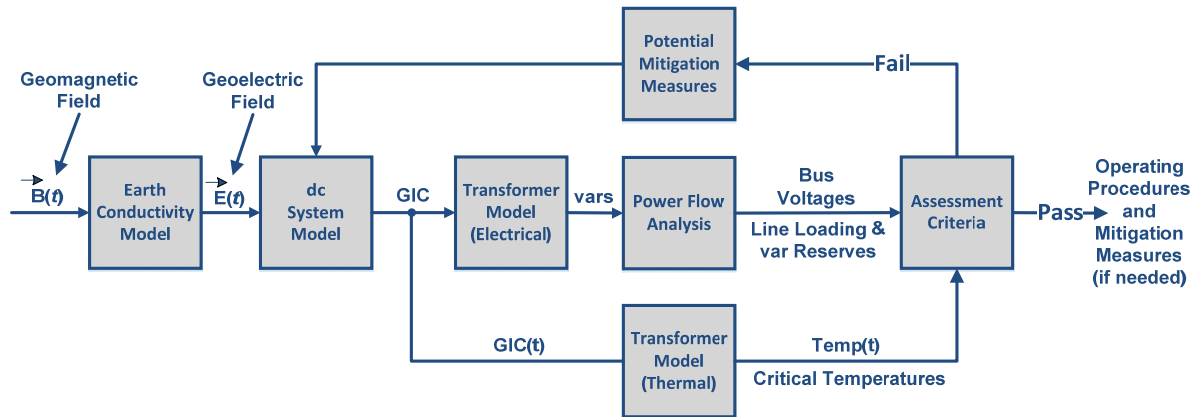
**Figure 6: Supplemental Geomagnetic Field Waveform  
Red  $B_N$  (Northward), Blue  $B_E$  (Eastward)**



**Figure 7: Supplemental Goelectric Field Waveform  
Blue  $E_N$  (Northward), Red  $E_E$  (Eastward)**

## Guidelines and Technical Basis

The diagram below provides an overall view of the GMD Vulnerability Assessment process:



The requirements in this standard cover various aspects of the GMD Vulnerability Assessment process.

### Benchmark GMD Event (Attachment 1)

The benchmark GMD event defines the geoelectric field values used to compute GIC flows that are needed to conduct a benchmark GMD Vulnerability Assessment. The *Benchmark Geomagnetic Disturbance Event Description*, May 2016<sup>11</sup> white paper includes the event description, analysis, and example calculations.

### Supplemental GMD Event (Attachment 1)

The supplemental GMD event defines the geoelectric field values used to compute GIC flows that are needed to conduct a supplemental GMD Vulnerability Assessment. The *Supplemental Geomagnetic Disturbance Event Description*, October 2017<sup>12</sup> white paper includes the event description and analysis.

### Requirement R2

A GMD Vulnerability Assessment requires a GIC System model, which is a dc representation of the System, to calculate GIC flow. In a GMD Vulnerability Assessment, GIC simulations are used to determine transformer Reactive Power absorption and transformer thermal response. Details for developing the GIC System model are provided in the NERC GMD Task Force guide: *Application Guide for Computing Geomagnetically-Induced Current in the Bulk Power System*, December 2013.<sup>13</sup>

Underground pipe-type cables present a special modeling situation in that the steel pipe that encloses the power conductors significantly reduces the geoelectric field induced into the

<sup>11</sup> <http://www.nerc.com/pa/stand/Pages/TPL0071RI.aspx>.

<sup>12</sup> <http://www.nerc.com/pa/Stand/Pages/Project-2013-03-Geomagnetic-Disturbance-Mitigation.aspx>.

<sup>13</sup> [http://www.nerc.com/comm/PC/Geomagnetic%20Disturbance%20Task%20Force%20GMDTF%202013/GIC%20Application%20Guide%202013\\_approved.pdf](http://www.nerc.com/comm/PC/Geomagnetic%20Disturbance%20Task%20Force%20GMDTF%202013/GIC%20Application%20Guide%202013_approved.pdf).

conductors themselves, while they remain a path for GIC. Solid dielectric cables that are not enclosed by a steel pipe will not experience a reduction in the induced geoelectric field. A planning entity should account for special modeling situations in the GIC system model, if applicable.

#### **Requirement R4**

The *Geomagnetic Disturbance Planning Guide*,<sup>14</sup> December 2013 developed by the NERC GMD Task Force provides technical information on GMD-specific considerations for planning studies.

#### **Requirement R5**

The benchmark thermal impact assessment of transformers specified in Requirement R6 is based on GIC information for the benchmark GMD Event. This GIC information is determined by the planning entity through simulation of the GIC System model and must be provided to the entity responsible for conducting the thermal impact assessment. GIC information should be provided in accordance with Requirement R5 each time the GMD Vulnerability Assessment is performed since, by definition, the GMD Vulnerability Assessment includes a documented evaluation of susceptibility to localized equipment damage due to GMD.

The maximum effective GIC value provided in Part 5.1 is used for the benchmark thermal impact assessment. Only those transformers that experience an effective GIC value of 75 A or greater per phase require evaluation in Requirement R6.

GIC(t) provided in Part 5.2 is used to convert the steady state GIC flows to time-series GIC data for the benchmark thermal impact assessment of transformers. This information may be needed by one or more of the methods for performing a benchmark thermal impact assessment. Additional information is in the following section and the *Transformer Thermal Impact Assessment White Paper*,<sup>15</sup> October 2017.

The peak GIC value of 75 Amps per phase has been shown through thermal modeling to be a conservative threshold below which the risk of exceeding known temperature limits established by technical organizations is low.

#### **Requirement R6**

The benchmark thermal impact assessment of a power transformer may be based on manufacturer-provided GIC capability curves, thermal response simulation, thermal impact screening, or other technically justified means. Approaches for conducting the assessment are presented in the *Transformer Thermal Impact Assessment White Paper ERO Enterprise-Endorsed*

---

<sup>14</sup> [http://www.nerc.com/comm/PC/Geomagnetic%20Disturbance%20Task%20Force%20GMDTF%202013/GMD%20Planning%20Guide\\_approved.pdf](http://www.nerc.com/comm/PC/Geomagnetic%20Disturbance%20Task%20Force%20GMDTF%202013/GMD%20Planning%20Guide_approved.pdf).

<sup>15</sup> <http://www.nerc.com/pa/Stand/Pages/Project-2013-03-Geomagnetic-Disturbance-Mitigation.aspx>.



*Implementation Guidance*<sup>16</sup> for this requirement. This ERO-Endorsed document is posted on the NERC Compliance Guidance<sup>17</sup> webpage.

Transformers are exempt from the benchmark thermal impact assessment requirement if the effective GIC value for the transformer is less than 75 A per phase, as determined by a GIC analysis of the System. Justification for this criterion is provided in the *Screening Criterion for Transformer Thermal Impact Assessment White Paper*,<sup>18</sup> October 2017. A documented design specification exceeding this value is also a justifiable threshold criterion that exempts a transformer from Requirement R6.

The benchmark threshold criteria and its associated transformer thermal impact must be evaluated on the basis of effective GIC. Refer to the white papers for additional information.

### **Requirement R7**

Technical considerations for GMD mitigation planning, including operating and equipment strategies, are available in Chapter 5 of the *Geomagnetic Disturbance Planning Guide*,<sup>19</sup> December 2013. Additional information is available in the *2012 Special Reliability Assessment Interim Report: Effects of Geomagnetic Disturbances on the Bulk-Power System*,<sup>20</sup> February 2012.

### **Requirement R8**

The *Geomagnetic Disturbance Planning Guide*,<sup>21</sup> December 2013 developed by the NERC GMD Task Force provides technical information on GMD-specific considerations for planning studies.

The supplemental GMD Vulnerability Assessment process is similar to the benchmark GMD Vulnerability Assessment process described under Requirement R4.

### **Requirement R9**

The supplemental thermal impact assessment specified of transformers in Requirement R10 is based on GIC information for the supplemental GMD Event. This GIC information is determined by the planning entity through simulation of the GIC System model and must be provided to the entity responsible for conducting the thermal impact assessment. GIC information should be provided in accordance with Requirement R9 each time the GMD Vulnerability Assessment is performed since, by definition, the GMD Vulnerability Assessment includes a documented evaluation of susceptibility to localized equipment damage due to GMD.

---

<sup>16</sup> [http://www.nerc.com/pa/comp/guidance/EROEndorsedImplementationGuidance/TPL-007-1\\_Transformer\\_Thermal\\_Impact\\_Assessment\\_White\\_Paper.pdf](http://www.nerc.com/pa/comp/guidance/EROEndorsedImplementationGuidance/TPL-007-1_Transformer_Thermal_Impact_Assessment_White_Paper.pdf).

<sup>17</sup> <http://www.nerc.com/pa/comp/guidance/Pages/default.aspx>.

<sup>18</sup> <http://www.nerc.com/pa/Stand/Pages/Project-2013-03-Geomagnetic-Disturbance-Mitigation.aspx>.

<sup>19</sup> [http://www.nerc.com/comm/PC/Geomagnetic%20Disturbance%20Task%20Force%20GMDTF%202013/GMD%20Planning%20Guide\\_approved.pdf](http://www.nerc.com/comm/PC/Geomagnetic%20Disturbance%20Task%20Force%20GMDTF%202013/GMD%20Planning%20Guide_approved.pdf).

<sup>20</sup> <http://www.nerc.com/pa/RAPA/ra/Reliability%20Assessments%20DL/2012GMD.pdf>.

<sup>21</sup> [http://www.nerc.com/comm/PC/Geomagnetic%20Disturbance%20Task%20Force%20GMDTF%202013/GMD%20Planning%20Guide\\_approved.pdf](http://www.nerc.com/comm/PC/Geomagnetic%20Disturbance%20Task%20Force%20GMDTF%202013/GMD%20Planning%20Guide_approved.pdf).

The maximum effective GIC value provided in Part 9.1 is used for the supplemental thermal impact assessment. Only those transformers that experience an effective GIC value of 85 A or greater per phase require evaluation in Requirement R10.

GIC(t) provided in Part 9.2 is used to convert the steady state GIC flows to time-series GIC data for the supplemental thermal impact assessment of transformers. This information may be needed by one or more of the methods for performing a supplemental thermal impact assessment. Additional information is in the following section.

The peak GIC value of 85 Amps per phase has been shown through thermal modeling to be a conservative threshold below which the risk of exceeding known temperature limits established by technical organizations is low.

### **Requirement R10**

The supplemental thermal impact assessment of a power transformer may be based on manufacturer-provided GIC capability curves, thermal response simulation, thermal impact screening, or other technically justified means. Approaches for conducting the assessment are presented in the *Transformer Thermal Impact Assessment White Paper ERO Enterprise-Endorsed Implementation Guidance*<sup>22</sup> discussed in the Requirement R6 section above. A later version of the *Transformer Thermal Impact Assessment White Paper*,<sup>23</sup> October 2017, has been developed to include updated information pertinent to the supplemental GMD event and supplemental thermal impact assessment.

Transformers are exempt from the supplemental thermal impact assessment requirement if the effective GIC value for the transformer is less than 85 A per phase, as determined by a GIC analysis of the System. Justification for this criterion is provided in the revised *Screening Criterion for Transformer Thermal Impact Assessment White Paper*,<sup>24</sup> October 2017. A documented design specification exceeding this value is also a justifiable threshold criterion that exempts a transformer from Requirement R10.

The supplemental threshold criteria and its associated transformer thermal impact must be evaluated on the basis of effective GIC. Refer to the white papers for additional information.

### **Requirement R11**

Technical considerations for GIC monitoring are contained in Chapter 6 of the *2012 Special Reliability Assessment Interim Report: Effects of Geomagnetic Disturbances on the Bulk-Power System*,<sup>25</sup> February 2012. GIC monitoring is generally performed by Hall effect transducers that are attached to the neutral of the wye-grounded transformer. Data from GIC monitors is useful for model validation and situational awareness.

---

<sup>22</sup> [http://www.nerc.com/pa/comp/guidance/EROEndorsedImplementationGuidance/TPL-007-1\\_Transformer\\_Thermal\\_Impact\\_Assessment\\_White\\_Paper.pdf](http://www.nerc.com/pa/comp/guidance/EROEndorsedImplementationGuidance/TPL-007-1_Transformer_Thermal_Impact_Assessment_White_Paper.pdf).

<sup>23</sup> <http://www.nerc.com/pa/Stand/Pages/Project-2013-03-Geomagnetic-Disturbance-Mitigation.aspx>.

<sup>24</sup> <http://www.nerc.com/pa/Stand/Pages/Project-2013-03-Geomagnetic-Disturbance-Mitigation.aspx>.

<sup>25</sup> <http://www.nerc.com/pa/RAPA/ra/Reliability%20Assessments%20DL/2012GMD.pdf>.

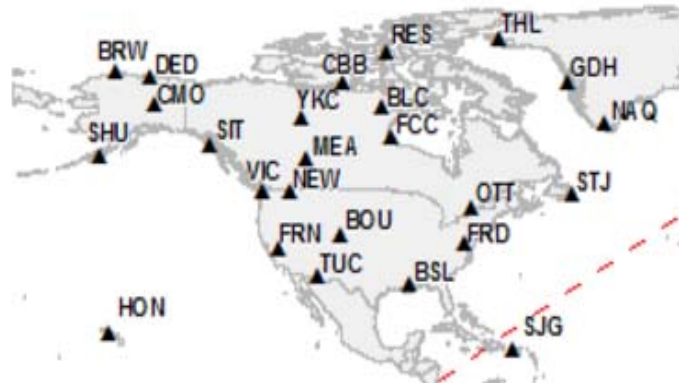
Responsible entities consider the following in developing a process for obtaining GIC monitor data:

- **Monitor locations.** An entity's operating process may be constrained by location of existing GIC monitors. However, when planning for additional GIC monitoring installations consider that data from monitors located in areas found to have high GIC based on system studies may provide more useful information for validation and situational awareness purposes. Conversely, data from GIC monitors that are located in the vicinity of transportation systems using direct current (e.g., subways or light rail) may be unreliable.
- **Monitor specifications.** Capabilities of Hall effect transducers, existing and planned, should be considered in the operating process. When planning new GIC monitor installations, consider monitor data range (e.g., -500 A through + 500 A) and ambient temperature ratings consistent with temperatures in the region in which the monitor will be installed.
- **Sampling Interval.** An entity's operating process may be constrained by capabilities of existing GIC monitors. However, when possible specify data sampling during periods of interest at a rate of 10 seconds or faster.
- **Collection Periods.** The process should specify when the entity expects GIC data to be collected. For example, collection could be required during periods where the Kp index is above a threshold, or when GIC values are above a threshold. Determining when to discontinue collecting GIC data should also be specified to maintain consistency in data collection.
- **Data format.** Specify time and value formats. For example, Greenwich Mean Time (GMT) (MM/DD/YYYY HH:MM:SS) and GIC Value (Ampere). Positive (+) and negative (-) signs indicate direction of GIC flow. Positive reference is flow from ground into transformer neutral. Time fields should indicate the sampled time rather than system or SCADA time if supported by the GIC monitor system.
- **Data retention.** The entity's process should specify data retention periods, for example 1 year. Data retention periods should be adequately long to support availability for the entity's model validation process and external reporting requirements, if any.
- **Additional information.** The entity's process should specify collection of other information necessary for making the data useful, for example monitor location and type of neutral connection (e.g., three-phase or single-phase).

### **Requirement R12**

Magnetometers measure changes in the earth's magnetic field. Entities should obtain data from the nearest accessible magnetometer. Sources of magnetometer data include:

- Observatories such as those operated by U.S. Geological Survey and Natural Resources Canada, see figure below for locations:<sup>26</sup>



- Research institutions and academic universities;
- Entities with installed magnetometers.

Entities that choose to install magnetometers should consider equipment specifications and data format protocols contained in the latest version of the *INTERMAGNET Technical Reference Manual*, Version 4.6, 2012.<sup>27</sup>

---

<sup>26</sup> <http://www.intermagnet.org/index-eng.php>.

<sup>27</sup> [http://www.intermagnet.org/publications/intermag\\_4-6.pdf](http://www.intermagnet.org/publications/intermag_4-6.pdf).

## Rationale

During development of TPL-007-1, text boxes were embedded within the standard to explain the rationale for various parts of the standard. The text from the rationale text boxes was moved to this section upon approval of TPL-007-1 by the NERC Board of Trustees. In developing TPL-007-2, the SDT has made changes to the sections below only when necessary for clarity. Changes are marked with brackets [ ].

### **Rationale for Applicability:**

Instrumentation transformers and station service transformers do not have significant impact on geomagnetically-induced current (GIC) flows; therefore, these transformers are not included in the applicability for this standard.

Terminal voltage describes line-to-line voltage.

### **Rationale for R1:**

In some areas, planning entities may determine that the most effective approach to conduct a GMD Vulnerability Assessment is through a regional planning organization. No requirement in the standard is intended to prohibit a collaborative approach where roles and responsibilities are determined by a planning organization made up of one or more Planning Coordinator(s).

### **Rationale for R2:**

A GMD Vulnerability Assessment requires a GIC System model to calculate GIC flow which is used to determine transformer Reactive Power absorption and transformer thermal response. Guidance for developing the GIC System model is provided in the *Application Guide Computing Geomagnetically-Induced Current in the Bulk-Power System*,<sup>28</sup> December 2013, developed by the NERC GMD Task Force.

The System model specified in Requirement R2 is used in conducting steady state power flow analysis that accounts for the Reactive Power absorption of power transformer(s) due to GIC in the System.

The GIC System model includes all power transformer(s) with a high side, wye-grounded winding with terminal voltage greater than 200 kV. The model is used to calculate GIC flow in the network.

The projected System condition for GMD planning may include adjustments to the System that are executable in response to space weather information. These adjustments could include, for example, recalling or postponing maintenance outages.

The Violation Risk Factor (VRF) for Requirement R2 is changed from Medium to High. This change is for consistency with the VRF for approved standard TPL-001-4 Requirement R1, which is proposed for revision in the NERC filing dated August 29, 2014 (Docket No. RM12-1-000). NERC guidelines require consistency among Reliability Standards.

---

<sup>28</sup> [http://www.nerc.com/comm/PC/Geomagnetic%20Disturbance%20Task%20Force%20GMDTF%202013/GIC%20Application%20Guide%202013\\_approved.pdf](http://www.nerc.com/comm/PC/Geomagnetic%20Disturbance%20Task%20Force%20GMDTF%202013/GIC%20Application%20Guide%202013_approved.pdf).

**Rationale for R3:**

Requirement R3 allows a responsible entity the flexibility to determine the System steady state voltage criteria for System steady state performance in Table 1. Steady state voltage limits are an example of System steady state performance criteria.

**Rationale for R4:**

The GMD Vulnerability Assessment includes steady state power flow analysis and the supporting study or studies using the models specified in Requirement R2 that account for the effects of GIC. Performance criteria are specified in Table 1.

At least one System On-Peak Load and at least one System Off-Peak Load must be examined in the analysis.

Distribution of GMD Vulnerability Assessment results provides a means for sharing relevant information with other entities responsible for planning reliability. Results of GIC studies may affect neighboring systems and should be taken into account by planners.

The *Geomagnetic Disturbance Planning Guide*,<sup>29</sup> December 2013 developed by the NERC GMD Task Force provides technical information on GMD-specific considerations for planning studies. The provision of information in Requirement R4, Part 4.3, shall be subject to the legal and regulatory obligations for the disclosure of confidential and/or sensitive information.

**Rationale for R5:**

This GIC information is necessary for determining the thermal impact of GIC on transformers in the planning area and must be provided to entities responsible for performing the thermal impact assessment so that they can accurately perform the assessment. GIC information should be provided in accordance with Requirement R5 as part of the GMD Vulnerability Assessment process since, by definition, the GMD Vulnerability Assessment includes documented evaluation of susceptibility to localized equipment damage due to GMD.

The maximum effective GIC value provided in Part 5.1 is used for transformer thermal impact assessment.

GIC(t) provided in Part 5.2 can alternatively be used to convert the steady state GIC flows to time-series GIC data for transformer thermal impact assessment. This information may be needed by one or more of the methods for performing a thermal impact assessment. Additional guidance is available in the *Transformer Thermal Impact Assessment White Paper*,<sup>30</sup> October 2017.

A Transmission Owner or Generator Owner that desires GIC(t) may request it from the planning entity. The planning entity shall provide GIC(t) upon request once GIC has been calculated, but

---

<sup>29</sup> [http://www.nerc.com/comm/PC/Geomagnetic%20Disturbance%20Task%20Force%20GMDTF%202013/GMD%20Planning%20Guide\\_approved.pdf](http://www.nerc.com/comm/PC/Geomagnetic%20Disturbance%20Task%20Force%20GMDTF%202013/GMD%20Planning%20Guide_approved.pdf).

<sup>30</sup> <http://www.nerc.com/pa/Stand/Pages/Project-2013-03-Geomagnetic-Disturbance-Mitigation.aspx>.

no later than 90 calendar days after receipt of a request from the owner and after completion of Requirement R5, Part 5.1.

The provision of information in Requirement R5 shall be subject to the legal and regulatory obligations for the disclosure of confidential and/or sensitive information.

**Rationale for R6:**

The transformer thermal impact screening criterion has been revised from 15 A per phase to 75 A per phase [for the benchmark GMD event]. Only those transformers that experience an effective GIC value of 75 A per phase or greater require evaluation in Requirement R6. The justification is provided in the *Screening Criterion for Transformer Thermal Impact Assessment White Paper*,<sup>31</sup> October 2017.

The thermal impact assessment may be based on manufacturer-provided GIC capability curves, thermal response simulation, thermal impact screening, or other technically justified means. The transformer thermal assessment will be repeated or reviewed using previous assessment results each time the planning entity performs a GMD Vulnerability Assessment and provides GIC information as specified in Requirement R5. Approaches for conducting the assessment are presented in the *Transformer Thermal Impact Assessment White Paper*,<sup>32</sup> October 2017.

Thermal impact assessments are provided to the planning entity, as determined in Requirement R1, so that identified issues can be included in the GMD Vulnerability Assessment (R4), and the Corrective Action Plan (R7) as necessary.

Thermal impact assessments of non-BES transformers are not required because those transformers do not have a wide-area effect on the reliability of the interconnected Transmission system.

The provision of information in Requirement R6, Part 6.4, shall be subject to the legal and regulatory obligations for the disclosure of confidential and/or sensitive information.

**Rationale for R7:**

The proposed requirement addresses directives in Order No. 830 for establishing Corrective Action Plan (CAP) deadlines associated with GMD Vulnerability Assessments. In Order No. 830, FERC directed revisions to TPL-007 such that CAPs are developed within one year from the completion of GMD Vulnerability Assessments (P 101). Furthermore, FERC directed establishment of implementation deadlines after the completion of the CAP as follows (P 102):

- Two years for non-hardware mitigation; and
- Four years for hardware mitigation.

The objective of Part 7.4 is to provide awareness to potentially impacted entities when implementation of planned mitigation is not achievable within the deadlines established in Part

---

<sup>31</sup> <http://www.nerc.com/pa/Stand/Pages/Project-2013-03-Geomagnetic-Disturbance-Mitigation.aspx>.

<sup>32</sup> <http://www.nerc.com/pa/Stand/Pages/Project-2013-03-Geomagnetic-Disturbance-Mitigation.aspx>.

7.3. Examples of situations beyond the control of the of the responsible entity (see Section 7.4) include, but are not limited to:

- Delays resulting from regulatory/legal processes, such as permitting;
- Delays resulting from stakeholder processes required by tariff;
- Delays resulting from equipment lead times; or

Delays resulting from the inability to acquire necessary Right-of-Way.

**Rationale for Table 3:**

Table 3 has been revised to use the same ground model designation, FL1, as is being used by USGS. The calculated scaling factor for FL1 is 0.74. [The scaling factor associated with the benchmark GMD event for the Florida earth model (FL1) has been updated to 0.76 in TPL-007-2 based on the earth model published on the USGS public website.]

**Rationale for R8 – R10:**

The proposed requirements address directives in Order No. 830 for revising the benchmark GMD event used in GMD Vulnerability Assessments (P 44, P 47-49). The requirements add a supplemental GMD Vulnerability Assessment based on the supplemental GMD event that accounts for localized peak geoelectric fields.

**Rationale for R11 – R12:**

The proposed requirements address directives in Order No. 830 for requiring responsible entities to collect GIC monitoring and magnetometer data as necessary to enable model validation and situational awareness (P 88; P. 90-92). GMD measurement data refers to GIC monitor data and geomagnetic field data in Requirements R11 and R12, respectively. See the Guidelines and Technical Basis section of this standard for technical information.

The objective of Requirement R11 is for entities to obtain GIC data for the Planning Coordinator's planning area or other part of the system included in the Planning Coordinator's GIC System model to inform GMD Vulnerability Assessments. Technical considerations for GIC monitoring are contained in Chapter 9 of the *2012 Special Reliability Assessment Interim Report: Effects of Geomagnetic Disturbances on the Bulk-Power System* (NERC 2012 GMD Report). GIC monitoring is generally performed by Hall effect transducers that are attached to the neutral of the transformer and measure dc current flowing through the neutral.

The objective of Requirement R12 is for entities to obtain geomagnetic field data for the Planning Coordinator's planning area to inform GMD Vulnerability Assessments. Magnetometers provide geomagnetic field data by measuring changes in the earth's magnetic field. Sources of geomagnetic field data include:

- Observatories such as those operated by U.S. Geological Survey, Natural Resources Canada, research organizations, or university research facilities;
- Installed magnetometers; and
- Commercial or third-party sources of geomagnetic field data.



Geomagnetic field data for a Planning Coordinator’s planning area is obtained from one or more of the above data sources located in the Planning Coordinator’s planning area, or by obtaining a geomagnetic field data product for the Planning Coordinator’s planning area from a government or research organization. The geomagnetic field data product does not need to be derived from a magnetometer or observatory within the Planning Coordinator’s planning area.

**Proposed Reliability Standard TPL-007-2 – Transmission System Planned Performance for  
Geomagnetic Disturbance Operations - Redline**

## Standard Development Timeline

This section is maintained by the drafting team during the development of the standard and will be removed when the standard is adopted by the NERC Board of Trustees (Board).

### Description of Current Draft

<u>Completed Actions</u>	<u>Date</u>
<u>Standards Committee approved Standard Authorization Request (SAR) for posting</u>	<u>December 14, 2016</u>
<u>SAR posted for comment</u>	<u>December 16, 2016 – January 20, 2017</u>
<u>45-day formal comment period with initial ballot</u>	<u>June 28 – August 11, 2017</u>

<u>Anticipated Actions</u>	<u>Date</u>
<u>10-day final ballot</u>	<u>October 2017</u>
<u>Board adoption</u>	<u>November 2017</u>

### **New or Modified Term(s) Used in NERC Reliability Standards**

This section includes all new or modified terms used in the proposed standard that will be included in the *Glossary of Terms Used in NERC Reliability Standards* upon applicable regulatory approval. Terms used in the proposed standard that are already defined and are not being modified can be found in the *Glossary of Terms Used in NERC Reliability Standards*. The new or revised terms listed below will be presented for approval with the proposed standard. Upon Board adoption, this section will be removed.

**Term(s):**

None

Upon Board adoption, the rationale boxes will be moved to the Supplemental Material Section.

## A. Introduction

1. **Title:** Transmission System Planned Performance for Geomagnetic Disturbance Events
2. **Number:** TPL-007-~~1~~2
3. **Purpose:** Establish requirements for Transmission system planned performance during geomagnetic disturbance (GMD) events.
4. **Applicability:**
  - 4.1. **Functional Entities:**
    - 4.1.1. Planning Coordinator with a planning area that includes a Facility or Facilities specified in 4.2;
    - 4.1.2. Transmission Planner with a planning area that includes a Facility or Facilities specified in 4.2;
    - 4.1.3. Transmission Owner who owns a Facility or Facilities specified in 4.2; and
    - 4.1.4. Generator Owner who owns a Facility or Facilities specified in 4.2.
  - 4.2. **Facilities:**
    - 4.2.1. Facilities that include power transformer(s) with a high side, wye-grounded winding with terminal voltage greater than 200 kV.
5. **Effective Date:** See Implementation Plan for TPL-007-~~1~~2.
6. **Background:** During a GMD event, geomagnetically-induced currents (GIC) may cause transformer hot-spot heating or damage, loss of Reactive Power sources, increased Reactive Power demand, and Misoperation(s), the combination of which may result in voltage collapse and blackout.

## B. Requirements and Measures

- R1.** Each Planning Coordinator, in conjunction with its Transmission Planner(s), shall identify the individual and joint responsibilities of the Planning Coordinator and Transmission Planner(s) in the Planning Coordinator’s planning area for maintaining models, ~~and~~ performing the study or studies needed to complete benchmark and supplemental GMD Vulnerability Assessment(s), and implementing process(es) to obtain GMD measurement data as specified in this standard. [Violation Risk Factor: Lower] [Time Horizon: Long-term Planning]
- M1.** Each Planning Coordinator, in conjunction with its Transmission Planners, shall provide documentation on roles and responsibilities, such as meeting minutes, agreements, copies of procedures or protocols in effect between entities or between departments of a vertically integrated system, or email correspondence that identifies an agreement has been reached on individual and joint responsibilities for maintaining models, ~~and~~ performing the study or studies needed to complete benchmark and supplemental GMD Vulnerability Assessment(s), and implementing process(es) to obtain GMD measurement data in accordance with Requirement R1.
- R2.** Each responsible entity, as determined in Requirement R1, shall maintain System models and GIC System models of the responsible entity’s planning area for performing the study or studies needed to complete benchmark and supplemental GMD Vulnerability Assessment(s). [Violation Risk Factor: High] [Time Horizon: Long-term Planning]
- M2.** Each responsible entity, as determined in Requirement R1, shall have evidence in either electronic or hard copy format that it is maintaining System models and GIC System models of the responsible entity’s planning area for performing the study or studies needed to complete benchmark and supplemental GMD Vulnerability Assessment(s).
- R3.** Each responsible entity, as determined in Requirement R1, shall have criteria for acceptable System steady state voltage performance for its System during the ~~benchmark~~ GMD events described in Attachment 1. [Violation Risk Factor: Medium] [Time Horizon: Long-term Planning]
- M3.** Each responsible entity, as determined in Requirement R1, shall have evidence, such as electronic or hard copies of the criteria for acceptable System steady state voltage performance for its System in accordance with Requirement R3.

### Benchmark GMD Vulnerability Assessment(s)

- R4.** Each responsible entity, as determined in Requirement R1, shall complete a benchmark GMD Vulnerability Assessment of the Near-Term Transmission Planning Horizon at least once every 60 calendar months. This benchmark GMD Vulnerability Assessment shall use a study or studies based on models identified in Requirement R2, document assumptions, and document summarized results of the steady state analysis. *[Violation Risk Factor: High] [Time Horizon: Long-term Planning]*
- 4.1.** The study or studies shall include the following conditions:
- 4.1.1.** System On-Peak Load for at least one year within the Near-Term Transmission Planning Horizon; and
- 4.1.2.** System Off-Peak Load for at least one year within the Near-Term Transmission Planning Horizon.
- 4.2.** The study or studies shall be conducted based on the benchmark GMD event described in Attachment 1 to determine whether the System meets the performance requirements for the steady state planning benchmark GMD event contained in Table 1.
- 4.3.** The benchmark GMD Vulnerability Assessment shall be provided ~~within 90 calendar days of completion: (i)~~ to the responsible entity's Reliability Coordinator, adjacent Planning Coordinators, and adjacent Transmission Planners, ~~and~~ within 90 calendar days of completion, and (ii) to any functional entity that submits a written request and has a reliability-related need within 90 calendar days of receipt of such request or within 90 calendar days of completion of the benchmark GMD Vulnerability Assessment, whichever is later.
- 4.3.1.** If a recipient of the benchmark GMD Vulnerability Assessment provides documented comments on the results, the responsible entity shall provide a documented response to that recipient within 90 calendar days of receipt of those comments.

- M4.** Each responsible entity, as determined in Requirement R1, shall have dated evidence such as electronic or hard copies of its benchmark GMD Vulnerability Assessment meeting all of the requirements in Requirement R4. Each responsible entity, as determined in Requirement R1, shall also provide evidence, such as email records, web postings with an electronic notice of posting, or postal receipts showing recipient and date, that it has distributed its benchmark GMD Vulnerability Assessment ~~within 90 calendar days of completion:~~ (i) to its the responsible entity's Reliability Coordinator, adjacent Planning Coordinator(s), and adjacent Transmission Planner(s) within 90 calendar days of completion, and (ii) to any functional entity who has submitted that submits a written request and has a reliability-related need within 90 calendar days of receipt of such request or within 90 calendar days of completion of the benchmark GMD Vulnerability Assessment, whichever is later, as specified in Requirement R4. Each responsible entity, as determined in Requirement R1, shall also provide evidence, such as email notices or postal receipts showing recipient and date, that it has provided a documented response to comments received on its benchmark GMD Vulnerability Assessment within 90 calendar days of receipt of those comments in accordance with Requirement R4.
- R5.** Each responsible entity, as determined in Requirement R1, shall provide GIC flow information to be used for the benchmark transformer thermal impact assessment of transformers specified in Requirement R6 to each Transmission Owner and Generator Owner that owns an applicable Bulk Electric System (BES) power transformer in the planning area. The GIC flow information shall include: *[Violation Risk Factor: Medium] [Time Horizon: Long-term Planning]*
- 5.1.** The maximum effective GIC value for the worst case geoelectric field orientation for the benchmark GMD event described in Attachment 1. This value shall be provided to the Transmission Owner or Generator Owner that owns each applicable BES power transformer in the planning area.
- 5.2.** The effective GIC time series, GIC(t), calculated using the benchmark GMD event described in Attachment 1 in response to a written request from the Transmission Owner or Generator Owner that owns an applicable BES power transformer in the planning area. GIC(t) shall be provided within 90 calendar days of receipt of the written request and after determination of the maximum effective GIC value in Part 5.1.
- M5.** Each responsible entity, as determined in Requirement R1, shall provide evidence, such as email records, web postings with an electronic notice of posting, or postal receipts showing recipient and date, that it has provided the maximum effective GIC values to the Transmission Owner and Generator Owner that owns each applicable BES power transformer in the planning area as specified in Requirement R5, Part 5.1. Each responsible entity, as determined in Requirement R1, shall also provide evidence, such as email records, web postings with an electronic notice of posting, or postal receipts showing recipient and date, that it has provided GIC(t) in response to a written request from the Transmission Owner or Generator Owner that owns an applicable BES power transformer in the planning area.



- R6.** Each Transmission Owner and Generator Owner shall conduct a benchmark thermal impact assessment for its solely and jointly owned applicable BES power transformers where the maximum effective GIC value provided in Requirement R5, Part 5.1, is 75 A per phase or greater. The benchmark thermal impact assessment shall: [*Violation Risk Factor: Medium*] [*Time Horizon: Long-term Planning*]
- 6.1.** Be based on the effective GIC flow information provided in Requirement R5;
  - 6.2.** Document assumptions used in the analysis;
  - 6.3.** Describe suggested actions and supporting analysis to mitigate the impact of GICs, if any; and
  - 6.4.** Be performed and provided to the responsible entities, as determined in Requirement R1, within 24 calendar months of receiving GIC flow information specified in Requirement R5, Part 5.1.
- M6.** Each Transmission Owner and Generator Owner shall have evidence such as electronic or hard copies of its benchmark thermal impact assessment for all of its solely and jointly owned applicable BES power transformers where the maximum effective GIC value provided in Requirement R5, Part 5.1, is 75 A per phase or greater, and shall have evidence such as email records, web postings with an electronic notice of posting, or postal receipts showing recipient and date, that it has provided its thermal impact assessment to the responsible entities as specified in Requirement R6.

**Rationale for Requirement R7:** The proposed requirement addresses directives in Order No. 830 for establishing Corrective Action Plan (CAP) deadlines associated with GMD Vulnerability Assessments. In Order No. 830, FERC directed revisions to TPL-007 such that CAPs are developed within one year from the completion of GMD Vulnerability Assessments (P 101). Furthermore, FERC directed establishment of implementation deadlines after the completion of the CAP as follows (P 102):

- Two years for non-hardware mitigation; and
- Four years for hardware mitigation.

The objective of Part 7.4 is to provide awareness to potentially impacted entities when implementation of planned mitigation is not achievable within the deadlines established in Part 7.3. Examples of situations beyond the control of the of the responsible entity (see Section 7.4) include, but are not limited to:

- Delays resulting from regulatory/legal processes, such as permitting;
- Delays resulting from stakeholder processes required by tariff;
- Delays resulting from equipment lead times; or
- Delays resulting from the inability to acquire necessary Right-of-Way.

R7. Each responsible entity, as determined in Requirement R1, that concludes, through the benchmark GMD Vulnerability Assessment conducted in Requirement R4, that their System does not meet the performance requirements for the steady state planning benchmark GMD event contained in ~~of~~ Table 1, shall develop a Corrective Action Plan (CAP) addressing how the performance requirements will be met. The ~~Corrective Action Plan~~ CAP shall: [Violation Risk Factor: High] [Time Horizon: Long-term Planning]

7.1. List System deficiencies and the associated actions needed to achieve required System performance. Examples of such actions include:

- Installation, modification, retirement, or removal of Transmission and generation Facilities and any associated equipment.
- Installation, modification, or removal of Protection Systems or Remedial Action Schemes~~Special Protection Systems~~.
- Use of Operating Procedures, specifying how long they will be needed as part of the ~~Corrective Action Plan~~ CAP.
- Use of Demand-Side Management, new technologies, or other initiatives.

7.2. Be developed within one year of completion of the benchmark ~~reviewed in subsequent~~ GMD Vulnerability Assessments ~~until it is determined that the System meets the performance requirements contained in Table 1.~~

7.3. ~~Be provided within 90 calendar days of completion to the responsible entity's Reliability Coordinator, adjacent Planning Coordinator(s), adjacent Transmission Planner(s), functional entities referenced in the Corrective Action Plan, and any functional entity that submits a written request and has a reliability related need.~~ Include a timetable, subject to revision by the responsible entity in Part 7.4, for implementing the selected actions from Part 7.1. The timetable shall:

~~7.3.1. If a recipient of the Corrective Action Plan provides documented comments on the results, the responsible entity shall provide a documented response to that recipient within 90 calendar days of receipt of those comments. Specify implementation of non-hardware mitigation, if any, within two years of development of the CAP; and~~

~~7.3.1.7.3.2. Specify implementation of hardware mitigation, if any, within four years of development of the CAP.~~

~~7.4. Be revised if situations beyond the control of the responsible entity determined in Requirement R1 prevent implementation of the CAP within the timetable for implementation provided in Part 7.3. The revised CAP shall document the following, and be updated at least once every 12 calendar months until implemented:~~

~~7.4.1. Circumstances causing the delay for fully or partially implementing the selected actions in Part 7.1;~~

~~7.4.2. Description of the original CAP, and any previous changes to the CAP, with the associated timetable(s) for implementing the selected actions in Part 7.1; and~~

~~7.4.3. Revisions to the selected actions in Part 7.1, if any, including utilization of Operating Procedures if applicable, and the updated timetable for implementing the selected actions.~~

~~7.4.7.5. Be provided within 90 calendar days of completion: (i) to the responsible entity's Reliability Coordinator, adjacent Planning Coordinator(s), adjacent Transmission Planner(s), and functional entities referenced in the Corrective Action Plan, and CAP within 90 calendar days of development or revision, and (ii) to any functional entity that submits a written request and has a reliability-related need within 90 calendar days of receipt of such request or within 90 calendar days of development or revision, whichever is later.~~

~~7.4.1.7.5.1. If a recipient of the Corrective Action Plan CAP provides documented comments on the results, the responsible entity shall provide a documented response to that recipient within 90 calendar days of receipt of those comments.~~

**M7.** Each responsible entity, as determined in Requirement R1, that concludes, through the benchmark GMD Vulnerability Assessment conducted in Requirement R4, that the responsible entity's System does not meet the performance requirements for the steady state planning benchmark GMD event contained in ~~of~~ Table 1 shall have evidence such as dated electronic or hard copies of its CAP Corrective Action Plan including timetable for implementing selected actions, as specified in Requirement R7. Each responsible entity, as determined in Requirement R1, shall also provide evidence, such as email records or postal receipts showing recipient and date, that it has revised its CAP if situations beyond the responsible entity's control prevent implementation of the CAP within the timetable specified. Each responsible entity, as

determined in Requirement R1, shall also provide evidence, such as email records, web postings with an electronic notice of posting, or postal receipts showing recipient and date, that it has distributed its ~~CAP Corrective Action Plan~~ or relevant information, if any, (i) to the responsible entity's Reliability Coordinator, adjacent Planning Coordinator(s), adjacent Transmission Planner(s), and functional entities referenced in the ~~Corrective Action Plan~~ CAP within 90 calendar days of development or revision, and (ii) to any functional entity that submits a written request and has a reliability-related need, within 90 calendar days of receipt of such request or within 90 calendar days of development or revision, whichever is later as specified in Requirement R7. Each responsible entity, as determined in Requirement R1, shall also provide evidence, such as email notices or postal receipts showing recipient and date, that it has provided a documented response to comments received on its ~~CAP Corrective Action Plan~~ within 90 calendar days of receipt of those comments, in accordance with Requirement R7.

### Supplemental GMD Vulnerability Assessment(s)

Rationale for Requirements R8 – R10: The proposed requirements address directives in Order No. 830 for revising the benchmark GMD event used in GMD Vulnerability Assessments (P 44, P 47-49). The requirements add a supplemental GMD Vulnerability Assessment based on the supplemental GMD event that accounts for localized peak geoelectric fields.

- R8.** Each responsible entity, as determined in Requirement R1, shall complete a supplemental GMD Vulnerability Assessment of the Near-Term Transmission Planning Horizon at least once every 60 calendar months. This supplemental GMD Vulnerability Assessment shall use a study or studies based on models identified in Requirement R2, document assumptions, and document summarized results of the steady state analysis. [Violation Risk Factor: High] [Time Horizon: Long-term Planning]
- 8.1.** The study or studies shall include the following conditions:
- 8.1.1.** System On-Peak Load for at least one year within the Near-Term Transmission Planning Horizon; and
  - 8.1.2.** System Off-Peak Load for at least one year within the Near-Term Transmission Planning Horizon.
- 8.2.** The study or studies shall be conducted based on the supplemental GMD event described in Attachment 1 to determine whether the System meets the performance requirements for the steady state planning supplemental GMD event contained in Table 1.

8.3. If the analysis concludes there is Cascading caused by the supplemental GMD event described in Attachment 1, an evaluation of possible actions designed to reduce the likelihood or mitigate the consequences and adverse impacts of the event(s) shall be conducted.

8.4. The supplemental GMD Vulnerability Assessment shall be provided: (i) to the responsible entity's Reliability Coordinator, adjacent Planning Coordinators, adjacent Transmission Planners within 90 calendar days of completion, and (ii) to any functional entity that submits a written request and has a reliability-related need within 90 calendar days of receipt of such request or within 90 calendar days of completion of the supplemental GMD Vulnerability Assessment, whichever is later.

8.4.1. If a recipient of the supplemental GMD Vulnerability Assessment provides documented comments on the results, the responsible entity shall provide a documented response to that recipient within 90 calendar days of receipt of those comments.

M8. Each responsible entity, as determined in Requirement R1, shall have dated evidence such as electronic or hard copies of its supplemental GMD Vulnerability Assessment meeting all of the requirements in Requirement R8. Each responsible entity, as determined in Requirement R1, shall also provide evidence, such as email records, web postings with an electronic notice of posting, or postal receipts showing recipient and date, that it has distributed its supplemental GMD Vulnerability: (i) to the responsible entity's Reliability Coordinator, adjacent Planning Coordinators, adjacent Transmission Planners within 90 calendar days of completion, and (ii) to any functional entity that submits a written request and has a reliability-related need within 90 calendar days of receipt of such request or within 90 calendar days of completion of the supplemental GMD Vulnerability Assessment, whichever is later, as specified in Requirement R8. Each responsible entity, as determined in Requirement R1, shall also provide evidence, such as email notices or postal receipts showing recipient and date, that it has provided a documented response to comments received on its supplemental GMD Vulnerability Assessment within 90 calendar days of receipt of those comments in accordance with Requirement R8.

R9. Each responsible entity, as determined in Requirement R1, shall provide GIC flow information to be used for the supplemental thermal impact assessment of transformers specified in Requirement R10 to each Transmission Owner and Generator Owner that owns an applicable Bulk Electric System (BES) power transformer in the planning area. The GIC flow information shall include: *[Violation Risk Factor: Medium] [Time Horizon: Long-term Planning]*

9.1. The maximum effective GIC value for the worst case geoelectric field orientation for the supplemental GMD event described in Attachment 1. This value shall be provided to the Transmission Owner or Generator Owner that owns each applicable BES power transformer in the planning area.

9.2. The effective GIC time series, GIC(t), calculated using the supplemental GMD event described in Attachment 1 in response to a written request from the Transmission Owner or Generator Owner that owns an applicable BES power transformer in the planning area. GIC(t) shall be provided within 90 calendar days of receipt of the written request and after determination of the maximum effective GIC value in Part 9.1.

M9. Each responsible entity, as determined in Requirement R1, shall provide evidence, such as email records, web postings with an electronic notice of posting, or postal receipts showing recipient and date, that it has provided the maximum effective GIC values to the Transmission Owner and Generator Owner that owns each applicable BES power transformer in the planning area as specified in Requirement R9, Part 9.1. Each responsible entity, as determined in Requirement R1, shall also provide evidence, such as email records, web postings with an electronic notice of posting, or postal receipts showing recipient and date, that it has provided GIC(t) in response to a written request from the Transmission Owner or Generator Owner that owns an applicable BES power transformer in the planning area.

R10. Each Transmission Owner and Generator Owner shall conduct a supplemental thermal impact assessment for its solely and jointly owned applicable BES power transformers where the maximum effective GIC value provided in Requirement R9, Part 9.1, is 85 A per phase or greater. The supplemental thermal impact assessment shall: *[Violation Risk Factor: Medium]* *[Time Horizon: Long-term Planning]*

10.1. Be based on the effective GIC flow information provided in Requirement R9;

10.2. Document assumptions used in the analysis;

10.3. Describe suggested actions and supporting analysis to mitigate the impact of GICs, if any; and

10.4. Be performed and provided to the responsible entities, as determined in Requirement R1, within 24 calendar months of receiving GIC flow information specified in Requirement R9, Part 9.1.

M10. Each Transmission Owner and Generator Owner shall have evidence such as electronic or hard copies of its supplemental thermal impact assessment for all of its solely and jointly owned applicable BES power transformers where the maximum effective GIC value provided in Requirement R9, Part 9.1, is 85 A per phase or greater, and shall have evidence such as email records, web postings with an electronic notice of posting, or postal receipts showing recipient and date, that it has provided its supplemental thermal impact assessment to the responsible entities as specified in Requirement R10.

### GMD Measurement Data Processes

Rationale for Requirements R11 and R12: The proposed requirements address directives in Order No. 830 for requiring responsible entities to collect GIC monitoring and magnetometer data as necessary to enable model validation and situational awareness (P 88; P. 90-92). GMD measurement data refers to GIC monitor data and geomagnetic field data in Requirements R11 and R12, respectively. See the Guidelines and Technical Basis section of this standard for technical information.

The objective of Requirement R11 is for entities to obtain GIC data for the Planning Coordinator's planning area or other part of the system included in the Planning Coordinator's GIC System model to inform GMD Vulnerability Assessments. Technical considerations for GIC monitoring are contained in Chapter 9 of the *2012 Special Reliability Assessment Interim Report: Effects of Geomagnetic Disturbances on the Bulk-Power System* (NERC 2012 GMD Report). GIC monitoring is generally performed by Hall effect transducers that are attached to the neutral of the transformer and measure dc current flowing through the neutral.

The objective of Requirement R12 is for entities to obtain geomagnetic field data for the Planning Coordinator's planning area to inform GMD Vulnerability Assessments. Magnetometers provide geomagnetic field data by measuring changes in the earth's magnetic field. Sources of geomagnetic field data include:

- Observatories such as those operated by U.S. Geological Survey, Natural Resources Canada, research organizations, or university research facilities;
- Installed magnetometers; and
- Commercial or third-party sources of geomagnetic field data.

Geomagnetic field data for a Planning Coordinator’s planning area is obtained from one or more of the above data sources located in the Planning Coordinator’s planning area, or by obtaining a geomagnetic field data product for the Planning Coordinator’s planning area from a government or research organization. The geomagnetic field data product does not need to be derived from a magnetometer or observatory within the Planning Coordinator’s planning area.

R11. Each responsible entity, as determined in Requirement R1, shall implement a process to obtain GIC monitor data from at least one GIC monitor located in the Planning Coordinator's planning area or other part of the system included in the Planning Coordinator's GIC System model. [Violation Risk Factor: Lower] [Time Horizon: Long-term Planning]

M11. Each responsible entity, as determined in Requirement R1, shall have evidence such as electronic or hard copies of its GIC monitor location(s) and documentation of its process to obtain GIC monitor data in accordance with Requirement R11.

R12. Each responsible entity, as determined in Requirement R1, shall implement a process to obtain geomagnetic field data for its Planning Coordinator’s planning area. [Violation Risk Factor: Lower] [Time Horizon: Long-term Planning]

M8-M12. Each responsible entity, as determined in Requirement R1, shall have evidence such as electronic or hard copies of its process to obtain geomagnetic field data for its Planning Coordinator’s planning area in accordance with Requirement R12.

## C. Compliance

### 1. Compliance Monitoring Process

**1.1. Compliance Enforcement Authority:** ~~“As defined in the NERC Rules of Procedure;~~ “Compliance Enforcement Authority” means NERC or the Regional Entity, or any entity as otherwise designated by an Applicable Governmental Authority, in their respective roles of monitoring and /or enforcing compliance with the NERC mandatory and enforceable Reliability Standards in their respective jurisdictions.

**1.2. Evidence Retention:** The following evidence retention ~~periods~~period(s) identify the period of time an entity is required to retain specific evidence to demonstrate compliance. For instances where the evidence retention period specified below is shorter than the time since the last audit, the ~~CEA~~Compliance Enforcement Authority may ask an entity to provide other evidence to show that it was compliant for the ~~full~~time period since the last audit.



~~The Planning Coordinator, Transmission Planner, Transmission Owner, and Generator Owner~~The applicable entity shall keep data or evidence to show compliance as identified below unless directed by its Compliance Enforcement Authority to retain specific evidence for a longer period of time as part of an investigation:

- For Requirements R1, R2, R3, R5, R6, R9, and ~~R6~~R10, each responsible entity shall retain documentation as evidence for five years.
- For Requirements R4 and R8, each responsible entity shall retain documentation of the current GMD Vulnerability Assessment and the preceding GMD Vulnerability Assessment.
- For Requirement R7, each responsible entity shall retain documentation as evidence for five years or until all actions in the Corrective Action Plan are completed, whichever is later.
- For Requirements R11 and R12, each responsible entity shall retain documentation as evidence for three years.

**1.3.** Compliance Monitoring and Enforcement Program: As defined in the NERC Rules of Procedure, “Compliance Monitoring and Enforcement Program” refers to the identification of the processes that will be used to evaluate data or information for the purpose of assessing performance or outcomes with the associated Reliability Standard.

~~Compliance Audits~~

~~Self-Certifications~~

~~Spot Checking~~

~~Compliance Investigations~~

~~Self-Reporting~~

~~Complaints~~

**~~1.4. Additional Compliance Information~~**

~~None~~

**Table 1 – Steady State Planning ~~Events~~ GMD Event**

**Steady State:**

- a. Voltage collapse, Cascading and uncontrolled islanding shall not occur.
- b. Generation loss is acceptable as a consequence of the steady state planning ~~event~~ GMD events.
- c. Planned System adjustments such as Transmission configuration changes and re-dispatch of generation are allowed if such adjustments are executable within the time duration applicable to the Facility Ratings.

Category	Initial Condition	Event	Interruption of Firm Transmission Service Allowed	Load Loss Allowed
<b>Benchmark GMD Event - GMD Event with Outages</b>	1. System as may be postured in response to space weather information <sup>1</sup> , and then 2. GMD event <sup>2</sup>	Reactive Power compensation devices and other Transmission Facilities removed as a result of Protection System operation or Misoperation due to harmonics during the GMD event	Yes <sup>3</sup>	Yes <sup>3</sup>
<b><u>Supplemental GMD Event - GMD Event with Outages</u></b>	<u>1. System as may be postured in response to space weather information<sup>1</sup>, and then</u> <u>2. GMD event<sup>2</sup></u>	<u>Reactive Power compensation devices and other Transmission Facilities removed as a result of Protection System operation or Misoperation due to harmonics during the GMD event</u>	<u>Yes</u>	<u>Yes</u>

**Table 1 – Steady State Performance Footnotes**

1. The System condition for GMD planning may include adjustments to posture the System that are executable in response to space weather information.
2. The GMD conditions for the benchmark and supplemental planning ~~event~~ events are described in Attachment 1 ~~(Benchmark GMD Event)~~.
3. Load loss as a result of manual or automatic Load shedding (e.g., UVLS) and/or curtailment of Firm Transmission Service may be used to meet BES performance requirements during studied GMD conditions. The likelihood and magnitude of Load loss or curtailment of Firm Transmission Service should be minimized.

### Violation Severity Levels

R #	Time Horizon	VRF	Violation Severity Levels			
			Lower VSL	Moderate VSL	High VSL	Severe VSL
R1.	Long-term Planning	Lower	N/A	N/A	N/A	The Planning Coordinator, in conjunction with its Transmission Planner(s), failed to determine and identify individual or joint responsibilities of the Planning Coordinator and Transmission Planner(s) in the Planning Coordinator’s planning area for maintaining models, <del>and</del> performing the study or studies needed to complete <u>benchmark and supplemental</u> GMD Vulnerability Assessment(s), <u>and implementing process(es) to obtain GMD measurement data as specified in this standard.</u>

R #	Time Horizon	VRF	Violation Severity Levels			
			Lower VSL	Moderate VSL	High VSL	Severe VSL
R2.	Long-term Planning	High	N/A	N/A	The responsible entity did not maintain either System models or GIC System models of the responsible entity's planning area for performing the <del>study or</del> studies needed to complete <u>benchmark and supplemental</u> GMD Vulnerability Assessment(s).	The responsible entity did not maintain both System models and GIC System models of the responsible entity's planning area for performing the <del>study or</del> studies needed to complete <u>benchmark and supplemental</u> GMD Vulnerability Assessment(s).
R3.	Long-term Planning	Medium	N/A	N/A	N/A	The responsible entity did not have criteria for acceptable System steady state voltage performance for its System during the <del>benchmark</del> GMD events described in Attachment 1 as required.

R #	Time Horizon	VRF	Violation Severity Levels			
			Lower VSL	Moderate VSL	High VSL	Severe VSL
R4.	Long-term Planning	High	The responsible entity completed a <u>benchmark</u> GMD Vulnerability Assessment, but it was more than 60 calendar months and less than or equal to 64 calendar months since the last <u>benchmark</u> GMD Vulnerability Assessment.	The responsible entity's completed <u>benchmark</u> GMD Vulnerability Assessment failed to satisfy one of <u>the</u> elements listed in Requirement R4, Parts 4.1 through 4.3; OR The responsible entity completed a <u>benchmark</u> GMD Vulnerability Assessment, but it was more than 64 calendar months and less than or equal to 68 calendar months since the last benchmark GMD Vulnerability Assessment.	The responsible entity's completed <u>benchmark</u> GMD Vulnerability Assessment failed to satisfy two of the elements listed in Requirement R4, Parts 4.1 through 4.3; OR The responsible entity completed a <u>benchmark</u> GMD Vulnerability Assessment, but it was more than 68 calendar months and less than or equal to 72 calendar months since the last <u>benchmark</u> GMD Vulnerability Assessment.	The responsible entity's completed <u>benchmark</u> GMD Vulnerability Assessment failed to satisfy three of the elements listed in Requirement R4, Parts 4.1 through 4.3; OR The responsible entity completed a <u>benchmark</u> GMD Vulnerability Assessment, but it was more than 72 calendar months since the last <u>benchmark</u> GMD Vulnerability Assessment; OR The responsible entity does not have a completed <u>benchmark</u> GMD Vulnerability Assessment.

R #	Time Horizon	VRF	Violation Severity Levels			
			Lower VSL	Moderate VSL	High VSL	Severe VSL
R5.	Long-term Planning	Medium	The responsible entity provided the effective GIC time series, GIC(t), in response to written request, but did so more than 90 calendar days and less than or equal to 100 calendar days after receipt of a written request.	The responsible entity provided the effective GIC time series, GIC(t), in response to written request, but did so more than 100 calendar days and less than or equal to 110 calendar days after receipt of a written request.	The responsible entity provided the effective GIC time series, GIC(t), in response to written request, but did so more than 110 calendar days after receipt of a written request.	The responsible entity did not provide the maximum effective GIC value to the Transmission Owner and Generator Owner that owns each applicable BES power transformer in the planning area; OR The responsible entity did not provide the effective GIC time series, GIC(t), upon written request.

R6.	Long-term Planning	Medium	<p>The responsible entity failed to conduct a <u>benchmark</u> thermal impact assessment for 5% or less or one of its solely owned and jointly owned applicable BES power transformers (whichever is greater) where the maximum effective GIC value provided in Requirement R5, Part 5.1, is 75 A or greater per phase;</p> <p>OR</p> <p>The responsible entity conducted a <u>benchmark</u> thermal impact assessment for its solely owned and jointly owned applicable BES power transformers where the maximum effective GIC value provided in Requirement R5, Part</p>	<p>The responsible entity failed to conduct a <u>benchmark</u> thermal impact assessment for more than 5% up to (and including) 10% or two of its solely owned and jointly owned applicable BES power transformers (whichever is greater) where the maximum effective GIC value provided in Requirement R5, Part 5.1, is 75 A or greater per phase;</p> <p>OR</p> <p>The responsible entity conducted a <u>benchmark</u> thermal impact assessment for its solely owned and jointly owned applicable BES power transformers where the maximum effective GIC value provided in Requirement R5, Part 5.1, is 75 A or greater</p>	<p>The responsible entity failed to conduct a <u>benchmark</u> thermal impact assessment for more than 10% up to (and including) 15% or three of its solely owned and jointly owned applicable BES power transformers (whichever is greater) where the maximum effective GIC value provided in Requirement R5, Part 5.1, is 75 A or greater per phase;</p> <p>OR</p> <p>The responsible entity conducted a <u>benchmark</u> thermal impact assessment for its solely owned and jointly owned applicable BES power transformers where the maximum effective GIC value provided in Requirement R5, Part 5.1, is 75 A or greater</p>	<p>The responsible entity failed to conduct a <u>benchmark</u> thermal impact assessment for more than 15% or more than three of its solely owned and jointly owned applicable BES power transformers (whichever is greater) where the maximum effective GIC value provided in Requirement R5, Part 5.1, is 75 A or greater per phase;</p> <p>OR</p> <p>The responsible entity conducted a <u>benchmark</u> thermal impact assessment for its solely owned and jointly owned applicable BES power transformers where the maximum effective GIC value provided in Requirement R5, Part 5.1, is 75 A or greater per phase but did so</p>
-----	--------------------	--------	--	--	---	--

R #	Time Horizon	VRF	Violation Severity Levels			
			Lower VSL	Moderate VSL	High VSL	Severe VSL
			5.1, is 75 A or greater per phase but did so more than 24 calendar months and less than or equal to 26 calendar months of receiving GIC flow information specified in Requirement R5, Part 5.1.	per phase but did so more than 26 calendar months and less than or equal to 28 calendar months of receiving GIC flow information specified in Requirement R5, Part 5.1; OR The responsible entity failed to include one of the required elements as listed in Requirement R6, Parts 6.1 through 6.3.	per phase but did so more than 28 calendar months and less than or equal to 30 calendar months of receiving GIC flow information specified in Requirement R5, Part 5.1; OR The responsible entity failed to include two of the required elements as listed in Requirement R6, Parts 6.1 through 6.3.	more than 30 calendar months of receiving GIC flow information specified in Requirement R5, Part 5.1; OR The responsible entity failed to include three of the required elements as listed in Requirement R6, Parts 6.1 through 6.3.



R #	Time Horizon	VRF	Violation Severity Levels			
			Lower VSL	Moderate VSL	High VSL	Severe VSL
R7.	Long-term Planning	High	<del>N/A</del> <u>The responsible entity's Corrective Action Plan failed to comply with one of the elements in Requirement R7, Parts 7.1 through 7.5.</u>	The responsible entity's Corrective Action Plan failed to comply with <del>one</del> <u>two</u> of the elements in Requirement R7, Parts 7.1 through 7. <del>3</del> <u>5</u> .	The responsible entity's Corrective Action Plan failed to comply with <del>two</del> <u>three</u> of the elements in Requirement R7, Parts 7.1 through 7. <del>3</del> <u>5</u> .	The responsible entity's Corrective Action Plan failed to comply with <u>four or more</u> <del>all three</del> of the elements in Requirement R7, Parts 7.1 through 7. <del>3</del> <u>5</u> ; OR The responsible entity did not have a Corrective Action Plan as required by Requirement R7.

R #	Time Horizon	VRF	Violation Severity Levels			
			Lower VSL	Moderate VSL	High VSL	Severe VSL
R8.			<p><u>The responsible entity completed a supplemental GMD Vulnerability Assessment, but it was more than 60 calendar months and less than or equal to 64 calendar months since the last supplemental GMD Vulnerability Assessment.</u></p> <p><u>OR</u></p> <p><u>The responsible entity's completed supplemental GMD Vulnerability Assessment failed to satisfy one of elements listed in Requirement R8, Parts 8.1 through 8.4;</u></p>	<p><u>The responsible entity's completed supplemental GMD Vulnerability Assessment failed to satisfy two of elements listed in Requirement R8, Parts 8.1 through 8.4;</u></p> <p><u>OR</u></p> <p><u>The responsible entity completed a supplemental GMD Vulnerability Assessment, but it was more than 64 calendar months and less than or equal to 68 calendar months since the last supplemental GMD Vulnerability Assessment.</u></p>	<p><u>The responsible entity's completed supplemental GMD Vulnerability Assessment failed to satisfy three of the elements listed in Requirement R8, Parts 8.1 through 8.4;</u></p> <p><u>OR</u></p> <p><u>The responsible entity completed a supplemental GMD Vulnerability Assessment, but it was more than 68 calendar months and less than or equal to 72 calendar months since the last supplemental GMD Vulnerability Assessment.</u></p>	<p><u>The responsible entity's completed supplemental GMD Vulnerability Assessment failed to satisfy four of the elements listed in Requirement R8, Parts 8.1 through 8.4;</u></p> <p><u>OR</u></p> <p><u>The responsible entity completed a supplemental GMD Vulnerability Assessment, but it was more than 72 calendar months since the last supplemental GMD Vulnerability Assessment;</u></p> <p><u>OR</u></p> <p><u>The responsible entity does not have a completed supplemental GMD Vulnerability Assessment.</u></p>

R #	Time Horizon	VRF	Violation Severity Levels			
			Lower VSL	Moderate VSL	High VSL	Severe VSL
R9.			<p><u>The responsible entity provided the effective GIC time series, GIC(t), in response to written request, but did so more than 90 calendar days and less than or equal to 100 calendar days after receipt of a written request.</u></p>	<p><u>The responsible entity provided the effective GIC time series, GIC(t), in response to written request, but did so more than 100 calendar days and less than or equal to 110 calendar days after receipt of a written request.</u></p>	<p><u>The responsible entity provided the effective GIC time series, GIC(t), in response to written request, but did so more than 110 calendar days after receipt of a written request.</u></p>	<p><u>The responsible entity did not provide the maximum effective GIC value to the Transmission Owner and Generator Owner that owns each applicable BES power transformer in the planning area;</u>  <u>OR</u>  <u>The responsible entity did not provide the effective GIC time series, GIC(t), upon written request.</u></p>

<p><u>R10.</u></p>			<p><u>The responsible entity failed to conduct a supplemental thermal impact assessment for 5% or less or one of its solely owned and jointly owned applicable BES power transformers (whichever is greater) where the maximum effective GIC value provided in Requirement R9, Part 9.1, is 85 A or greater per phase;</u>  <u>OR</u>  <u>The responsible entity conducted a supplemental thermal impact assessment for its solely owned and jointly owned applicable BES power transformers where the maximum effective GIC value</u></p>	<p><u>The responsible entity failed to conduct a supplemental thermal impact assessment for more than 5% up to (and including) 10% or two of its solely owned and jointly owned applicable BES power transformers (whichever is greater) where the maximum effective GIC value provided in Requirement R9, Part 9.1, is 85 A or greater per phase;</u>  <u>OR</u>  <u>The responsible entity conducted a supplemental thermal impact assessment for its solely owned and jointly owned applicable BES power transformers where the maximum effective GIC value provided in Requirement R9, Part 9.1, is 85 A or greater</u></p>	<p><u>The responsible entity failed to conduct a supplemental thermal impact assessment for more than 10% up to (and including) 15% or three of its solely owned and jointly owned applicable BES power transformers (whichever is greater) where the maximum effective GIC value provided in Requirement R9, Part 9.1, is 85 A or greater per phase;</u>  <u>OR</u>  <u>The responsible entity conducted a supplemental thermal impact assessment for its solely owned and jointly owned applicable BES power transformers where the maximum effective GIC value provided in Requirement R9, Part 9.1, is 85 A or greater</u></p>	<p><u>The responsible entity failed to conduct a supplemental thermal impact assessment for more than 15% or more than three of its solely owned and jointly owned applicable BES power transformers (whichever is greater) where the maximum effective GIC value provided in Requirement R9, Part 9.1, is 85 A or greater per phase;</u>  <u>OR</u>  <u>The responsible entity conducted a supplemental thermal impact assessment for its solely owned and jointly owned applicable BES power transformers where the maximum effective GIC value provided in Requirement R9, Part 9.1, is 85 A or greater per phase but did so</u></p>
--------------------	--	--	--	---	--	---

R #	Time Horizon	VRF	Violation Severity Levels			
			Lower VSL	Moderate VSL	High VSL	Severe VSL
			<p><u>provided in Requirement R9, Part 9.1, is 85 A or greater per phase but did so more than 24 calendar months and less than or equal to 26 calendar months of receiving GIC flow information specified in Requirement R9, Part 9.1.</u></p>	<p><u>per phase but did so more than 26 calendar months and less than or equal to 28 calendar months of receiving GIC flow information specified in Requirement R9, Part 9.1</u>                      OR  <u>The responsible entity failed to include one of the required elements as listed in Requirement R10, Parts 10.1 through 10.3.</u></p>	<p><u>per phase but did so more than 28 calendar months and less than or equal to 30 calendar months of receiving GIC flow information specified in Requirement R9, Part 9.1;</u>                      OR  <u>The responsible entity failed to include two of the required elements as listed in Requirement R10, Parts 10.1 through 10.3.</u></p>	<p><u>more than 30 calendar months of receiving GIC flow information specified in Requirement R9, Part 9.1;</u>                      OR  <u>The responsible entity failed to include three of the required elements as listed in Requirement R10, Parts 10.1 through 10.3.</u></p>

R #	Time Horizon	VRF	Violation Severity Levels			
			Lower VSL	Moderate VSL	High VSL	Severe VSL
<u>R11.</u>			<u>N/A</u>	<u>N/A</u>	<u>N/A</u>	<u>The responsible entity did not implement a process to obtain GIC monitor data from at least one GIC monitor located in the Planning Coordinator’s planning area or other part of the system included in the Planning Coordinator’s GIC System Model.</u>
<u>R12.</u>			<u>N/A</u>	<u>N/A</u>	<u>N/A</u>	<u>The responsible entity did not implement a process to obtain geomagnetic field data for its Planning Coordinator’s planning area.</u>

**C. Regional Variances**

None.

**D. Associated Documents**

Attachment 1

## Version History

Version	Date	Action	Change Tracking
1	December 17, 2014	Adopted by the NERC Board of Trustees	New
<u>2</u>	<u>TBD</u>	<u>Revised to respond to directives in FERC Order No. 830.</u>	<u>Revised</u>

## Attachment 1

### Calculating Geoelectric Fields for the Benchmark and Supplemental GMD Events

The benchmark GMD event<sup>1</sup> defines the geoelectric field values used to compute GIC flows that are needed to conduct a benchmark GMD Vulnerability Assessment. It is composed of the following elements: (1) a reference peak geoelectric field amplitude of 8 V/km derived from statistical analysis of historical magnetometer data; (2) scaling factors to account for local geomagnetic latitude; (3) scaling factors to account for local earth conductivity; and (4) a reference geomagnetic field time series or waveshape-waveform to facilitate time-domain analysis of GMD impact on equipment.

The supplemental GMD event is composed of similar elements as described above, except (1) the reference peak geoelectric field amplitude is 12 V/km over a localized area; and (2) the geomagnetic field time series or waveform includes a local enhancement in the waveform.<sup>2</sup>

The regional geoelectric field peak amplitude used in GMD Vulnerability Assessment,  $E_{peak}$ , can be obtained from the reference geoelectric field value of 8 V/km for the benchmark GMD event (1) or 12 V/km for the supplemental GMD event (2) using the following relationships:

$$E_{peak} = 8 \times \alpha \times \beta_b \text{ (V/km)} \quad (1)$$

$$E_{peak} = 12 \times \alpha \times \beta_s \text{ (V/km)} \quad (2)$$

where,  $\alpha$  is the scaling factor to account for local geomagnetic latitude, and  $\beta$  is a scaling factor to account for the local earth conductivity structure. Subscripts  $b$  and  $s$  for the  $\beta$  scaling factor denote association with the benchmark or supplemental GMD events, respectively.

### Scaling the Geomagnetic Field

The benchmark and supplemental GMD events is-are defined for geomagnetic latitude of 60° and ~~it~~ must be scaled to account for regional differences based on geomagnetic latitude. Table 2 provides a scaling factor correlating peak geoelectric field to geomagnetic latitude. Alternatively, the scaling factor  $\alpha$  is computed with the empirical expression:

$$\alpha = 0.001 \times e^{(0.115 \times L)} \quad (23)$$

where,  $L$  is the geomagnetic latitude in degrees and  $0.1 \leq \alpha \leq 1$ .

<sup>1</sup> The ~~benchmark~~ Benchmark GMD-Geomagnetic Disturbance event-Event description-Description, May 2016 is available on the Related Information webProject 2013-03-Geomagnetic Disturbance Mitigation project page for TPL-007-1: [http://www.nerc.com/pa/Stand/TPL0071RD/Benchmark\\_clean\\_May12\\_complete.pdf](http://www.nerc.com/pa/Stand/TPL0071RD/Benchmark_clean_May12_complete.pdf).

<sup>2</sup> The extent of local enhancements is on the order of 100 km in North-South (latitude) direction but longer in East-West (longitude) direction. The local enhancement in the geomagnetic field occurs over the time period of 2-5 minutes. Additional information is available in the Supplemental Geomagnetic Disturbance Event Description, October 2017 white paper on the Project 2013-03 Geomagnetic Disturbance Mitigation project webpage: <http://www.nerc.com/pa/Stand/Pages/Project-2013-03-Geomagnetic-Disturbance-Mitigation.aspx>.



For large planning areas that cover more than one scaling factor from Table 2, the GMD Vulnerability Assessment should be based on a peak geoelectric field that is:

- calculated by using the most conservative (largest) value for  $\alpha$ ; or
- calculated assuming a non-uniform or piecewise uniform geomagnetic field.

Table 2: — <u>Geomagnetic Field Scaling Factors for the Benchmark and Supplemental GMD Events</u>	
Geomagnetic Latitude (Degrees)	Scaling Factor1 ( $\alpha$ )
≤ 40	0.10
45	0.2
50	0.3
54	0.5
56	0.6
57	0.7
58	0.8
59	0.9
≥ 60	1.0

### Scaling the Geoelectric Field

The benchmark GMD event is defined for the reference Quebec earth model described in Table 4. The peak geoelectric field,  $E_{peak}$ , used in a GMD Vulnerability Assessment may be obtained by either:

- Calculating the geoelectric field for the ground conductivity in the planning area and the reference geomagnetic field time series scaled according to geomagnetic latitude, using a procedure such as the plane wave method described in the NERC GMD Task Force GIC Application Guide;<sup>3</sup> or
- Using the earth conductivity scaling factor  $\beta$  from Table 3 that correlates to the ground conductivity map in Figure 1 or Figure 2. Along with the scaling factor  $\alpha$  from equation (23) or Table 2,  $\beta$  is applied to the reference geoelectric field using equation (1 or 2, as applicable) to obtain the regional geoelectric field peak amplitude  $E_{peak}$  to be used in GMD Vulnerability Assessments. When a ground conductivity model is not available, the planning entity should use the largest  $\beta$  factor of adjacent physiographic regions or a technically justified value.

<sup>3</sup> Available at the NERC GMD Task Force project webpage: [http://www.nerc.com/comm/PC/Pages/Geomagnetic-Disturbance-Task-Force-\(GMDTF\)-2013.aspx](http://www.nerc.com/comm/PC/Pages/Geomagnetic-Disturbance-Task-Force-(GMDTF)-2013.aspx)

The earth models used to calculate Table 3 for the United States were obtained from publicly available information published on the U. S. Geological Survey website.<sup>4</sup> The models used to calculate Table 3 for Canada were obtained from Natural Resources Canada (NRCan) and reflect the average structure for large regions. A planner can also use specific earth model(s) with documented justification and the reference geomagnetic field time series to calculate the  $\beta$  factor(s) as follows:

$$\beta_b = E/8 \text{ for the benchmark GMD event} \quad (34)$$

$$\beta_s = E/12 \text{ for the supplemental GMD} \quad (5)$$

where,  $E$  is the absolute value of peak geoelectric in V/km obtained from the technically justified earth model and the reference geomagnetic field time series.

For large planning areas that span more than one  $\beta$  scaling factor, the most conservative (largest) value for  $\beta$  may be used in determining the peak geoelectric field to obtain conservative results. Alternatively, a planner could perform analysis using a non-uniform or piecewise uniform geoelectric field.

#### **Applying the Localized Peak Geoelectric Field in the Supplemental GMD Event**

The peak geoelectric field of the supplemental GMD event occurs in a localized area.<sup>5</sup> Planners have flexibility to determine how to apply the localized peak geoelectric field over the planning area in performing GIC calculations. Examples of approaches are:

- Apply the peak geoelectric field (12 V/km scaled to the planning area) over the entire planning area;
- Apply a spatially limited (12 V/km scaled to the planning area) peak geoelectric field (e.g., 100 km in North-South latitude direction and 500 km in East-West longitude direction) over a portion(s) of the system, and apply the benchmark GMD event over the rest of the system; or
- Other methods to adjust the benchmark GMD event analysis to account for the localized geoelectric field enhancement of the supplemental GMD event.

---

<sup>4</sup> Available at <http://geomag.usgs.gov/conductivity/>.

<sup>5</sup> See the Supplemental Geomagnetic Disturbance Description white paper located on the Project 2013-03 Geomagnetic Disturbance Mitigation project webpage: <http://www.nerc.com/pa/Stand/Pages/Project-2013-03-Geomagnetic-Disturbance-Mitigation.aspx>.

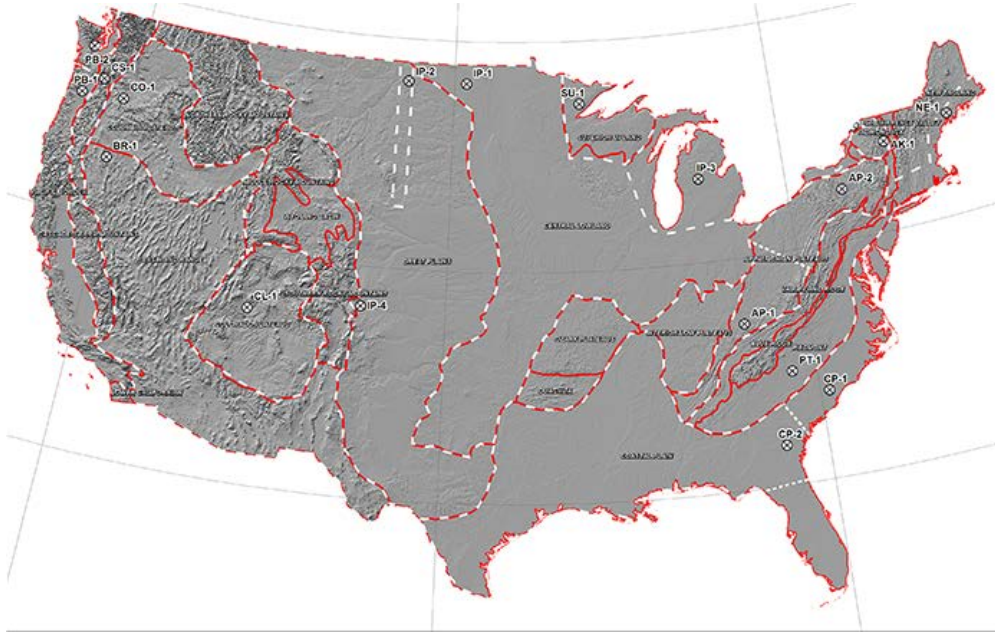


Figure 1: Physiographic Regions of the Continental United States<sup>6</sup>



Figure 2: Physiographic Regions of Canada

<sup>6</sup> Additional map detail is available at the U.S. Geological Survey: <http://geomag.usgs.gov/>.

<b>Table 3: Geoelectric Field Scaling Factors</b>		
<b>USGS Earth model</b>	<b>Scaling Factor Benchmark Event <math>(\beta_b)</math></b>	<b>Scaling Factor Supplemental Event <math>(\beta_s)</math></b>
AK1A	0.56	<u>0.51</u>
AK1B	0.56	<u>0.51</u>
AP1	0.33	<u>0.30</u>
AP2	0.82	<u>0.78</u>
BR1	0.22	<u>0.22</u>
CL1	0.76	<u>0.73</u>
CO1	0.27	<u>0.25</u>
CP1	0.81	<u>0.77</u>
CP2	0.95	<u>0.86</u>
FL1	0. <del>74</del> <u>76</u>	<u>0.73</u>
CS1	0.41	<u>0.37</u>
IP1	0.94	<u>0.90</u>
IP2	0.28	<u>0.25</u>
IP3	0.93	<u>0.90</u>
IP4	0.41	<u>0.35</u>
NE1	0.81	<u>0.77</u>
PB1	0.62	<u>0.55</u>
PB2	0.46	<u>0.39</u>
PT1	1.17	<u>1.19</u>
SL1	0.53	<u>0.49</u>
SU1	0.93	<u>0.90</u>
BOU	0.28	<u>0.24</u>
FBK	0.56	<u>0.56</u>
PRU	0.21	<u>0.22</u>
BC	0.67	<u>0.62</u>
PRAIRIES	0.96	<u>0.88</u>
SHIELD	1.0	<u>1.0</u>
ATLANTIC	0.79	<u>0.76</u>

**Rationale:** Scaling factors in Table 3 are dependent upon the frequency content of the reference storm. Consequently, the benchmark GMD event and the supplemental GMD event may produce different scaling factors for a given earth model.

The scaling factor associated with the benchmark GMD event for the Florida earth model (FL1) has been updated based on the earth model published on the USGS public website.

Layer Thickness (km)	Resistivity ( $\Omega$ -m)
15	20,000
10	200
125	1,000
200	100
$\infty$	3

**Reference Geomagnetic Field Time Series or Waveform for the Benchmark GMD Event**  
~~Waveform for the Benchmark GMD Event~~<sup>7</sup>

The geomagnetic field measurement record of the March 13-14 1989 GMD event, measured at ~~the NRC~~<sup>NARCA</sup>'s Ottawa geomagnetic observatory, is the basis for the reference geomagnetic field waveform to be used to calculate the GIC time series, GIC(t), required for transformer thermal impact assessment.

The geomagnetic latitude of the Ottawa geomagnetic observatory is 55°; therefore, the amplitudes<sub>s</sub> of the geomagnetic field measurement data were scaled up to the 60° reference geomagnetic latitude (see Figure 3) such that the resulting peak geoelectric field amplitude computed using the reference earth model was 8 V/km (see Figures 4 and 5). ~~The S~~<sub>s</sub> sampling rate for the geomagnetic field waveform ~~waveshape~~ is 10 seconds.<sup>8</sup> To use this geoelectric field time series when a different earth model is applicable, it should be scaled with the appropriate benchmark conductivity scaling factor  $\beta_b$ .

<sup>7</sup> Refer to the Benchmark Geomagnetic Disturbance GMD-Event Description white paper for details on the determination of the reference geomagnetic field waveform~~waveshape~~: <http://www.nerc.com/pa/stand/Pages/TPL0071RI.aspx>.

<sup>8</sup> The data file of the benchmark geomagnetic field ~~waveshape~~-waveform is available on the Related Information webpage for TPL-007-1/NERC GMD Task Force project page: <http://www.nerc.com/pa/stand/Pages/TPL0071RI.aspx>.

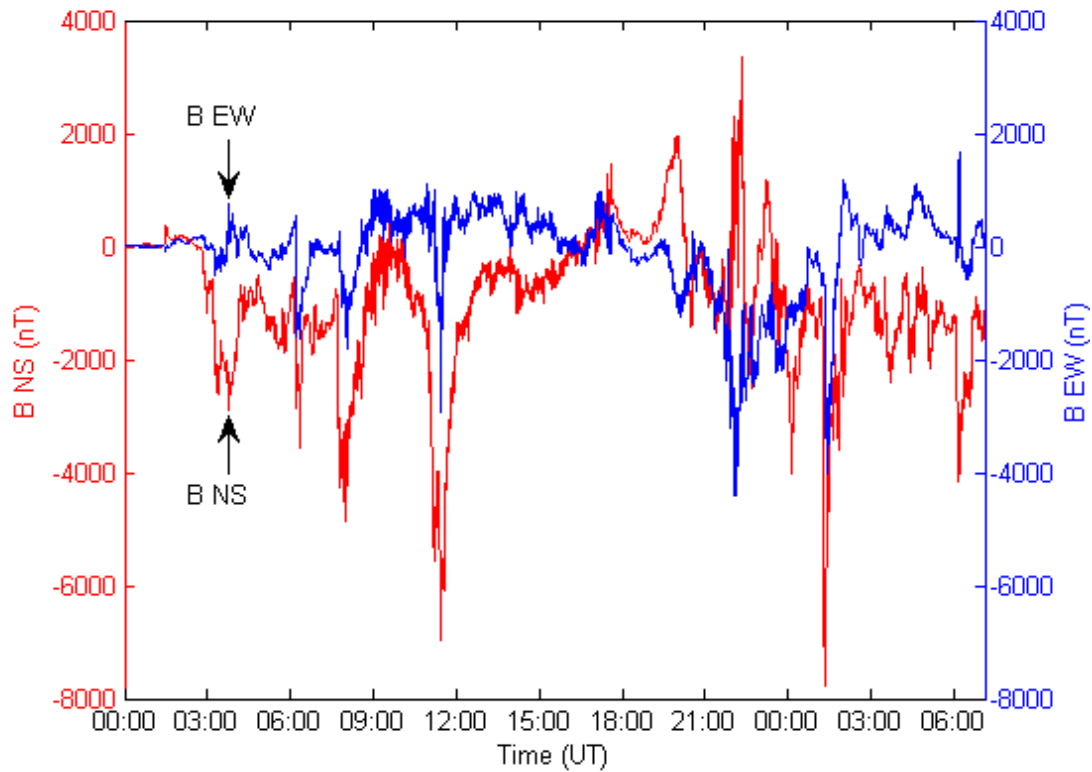


Figure 3: Benchmark Geomagnetic Field Waveform Waveshape  
Red  $B_n$  (Northward), Blue  $B_e$  (Eastward)

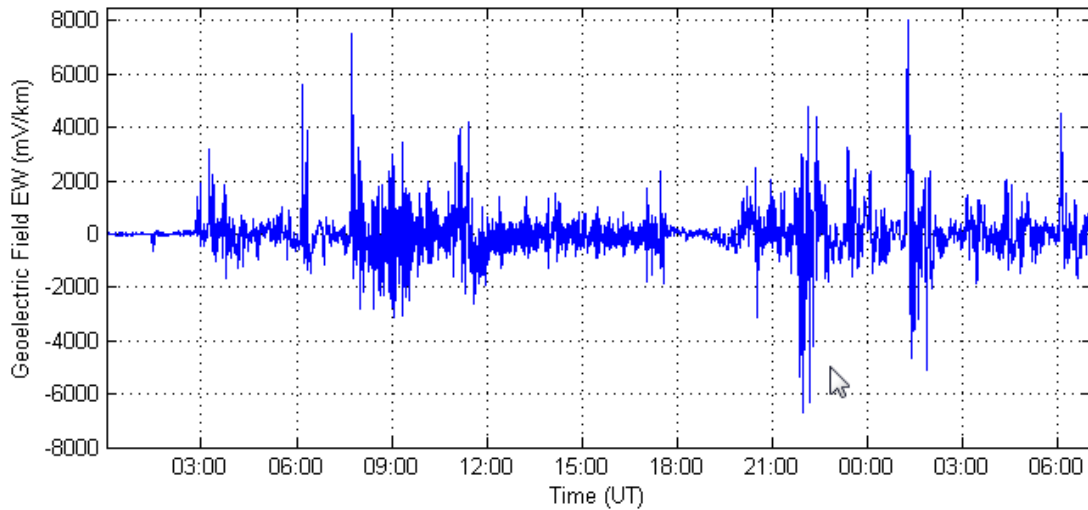


Figure 4: Benchmark Geoelectric Field Waveform Waveshape  
 $E_E$  (Eastward)

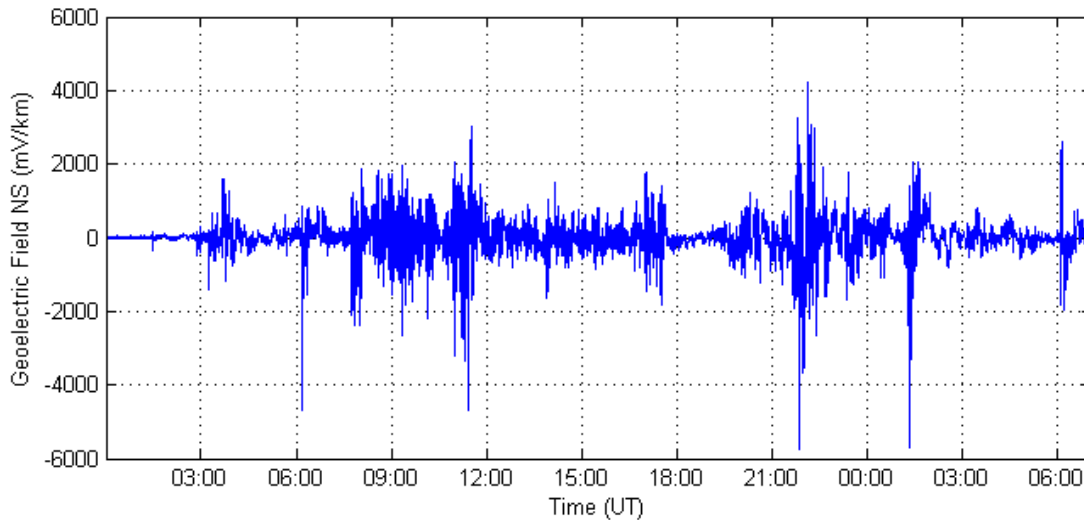


Figure 5: Benchmark Geoelectric Field ~~Waveform~~ **Waveshape**  
 $E_N$  (Northward)

**1.5.1.4.**

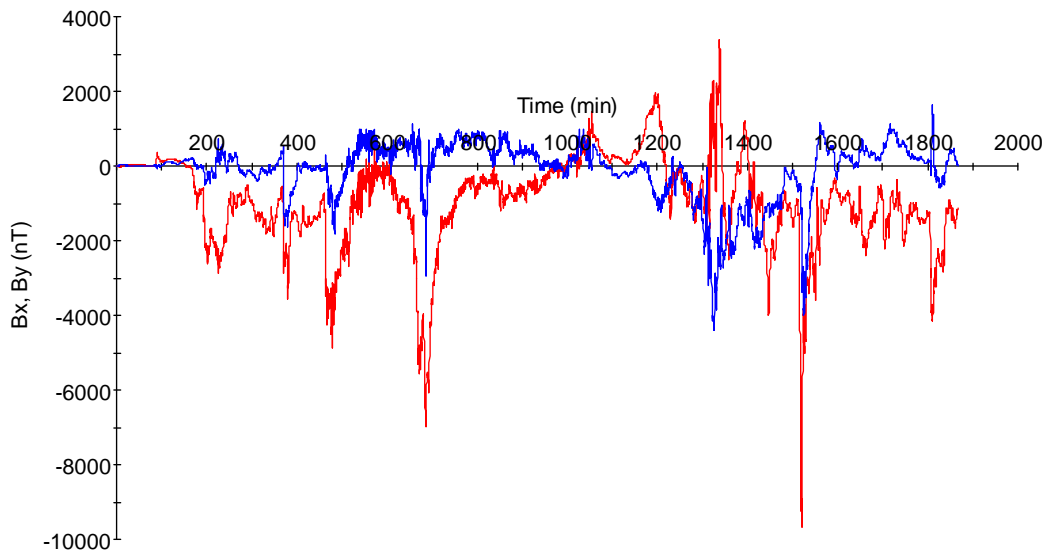
**Reference Geomagnetic Field Time Series or Waveform for the Supplemental GMD Event<sup>9</sup>**

The geomagnetic field measurement record of the March 13-14, 1989 GMD event, measured at the NRCan Ottawa geomagnetic observatory, is the basis for the reference geomagnetic field waveform to be used to calculate the GIC time series,  $GIC(t)$ , required for transformer thermal impact assessment for the supplemental GMD event. The supplemental GMD event waveform differs from the benchmark GMD event waveform in that the supplemental GMD event waveform has a local enhancement.

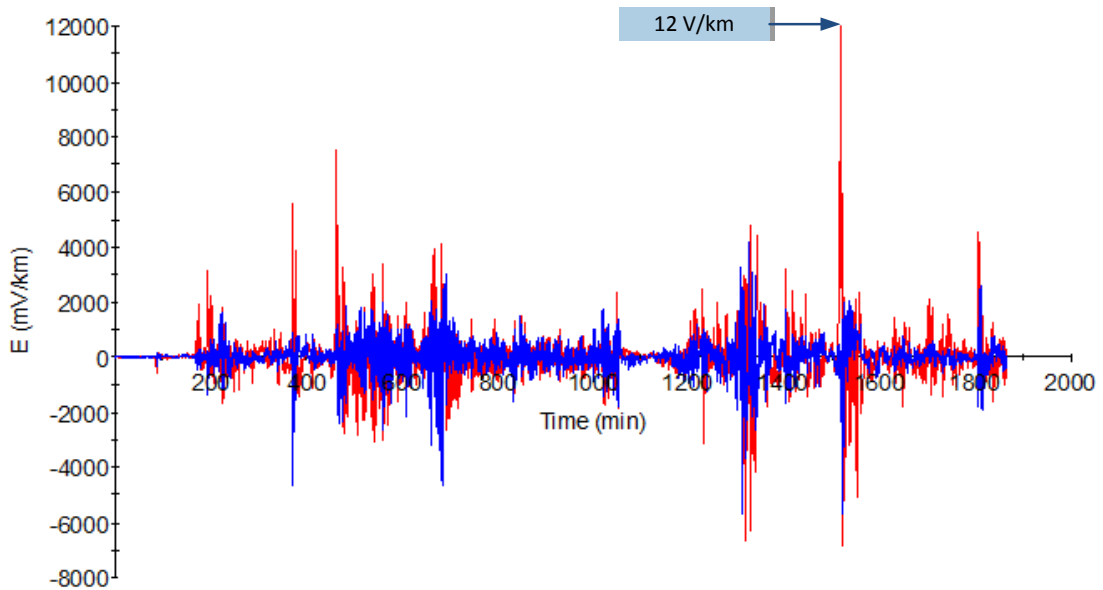
The geomagnetic latitude of the Ottawa geomagnetic observatory is  $55^\circ$ ; therefore, the amplitudes of the geomagnetic field measurement data were scaled up to the  $60^\circ$  reference geomagnetic latitude (see Figure 6) such that the resulting peak geoelectric field amplitude computed using the reference earth model was 12 V/km (see Figure 7). The sampling rate for the geomagnetic field waveform is 10 seconds.<sup>10</sup> To use this geoelectric field time series when a different earth model is applicable, it should be scaled with the appropriate supplemental conductivity scaling factor  $\beta_s$ .

<sup>9</sup> Refer to the Supplemental Geomagnetic Disturbance Event Description white paper for details on the determination of the reference geomagnetic field waveform: <http://www.nerc.com/pa/Stand/Pages/Project-2013-03-Geomagnetic-Disturbance-Mitigation.aspx>.

<sup>10</sup> The data file of the benchmark geomagnetic field waveform is available on the NERC GMD Task Force project webpage: [http://www.nerc.com/comm/PC/Pages/Geomagnetic-Disturbance-Task-Force-\(GMDTF\)-2013.aspx](http://www.nerc.com/comm/PC/Pages/Geomagnetic-Disturbance-Task-Force-(GMDTF)-2013.aspx).



**Figure 6: Supplemental Geomagnetic Field Waveform**  
**Red  $B_N$  (Northward), Blue  $B_E$  (Eastward)**

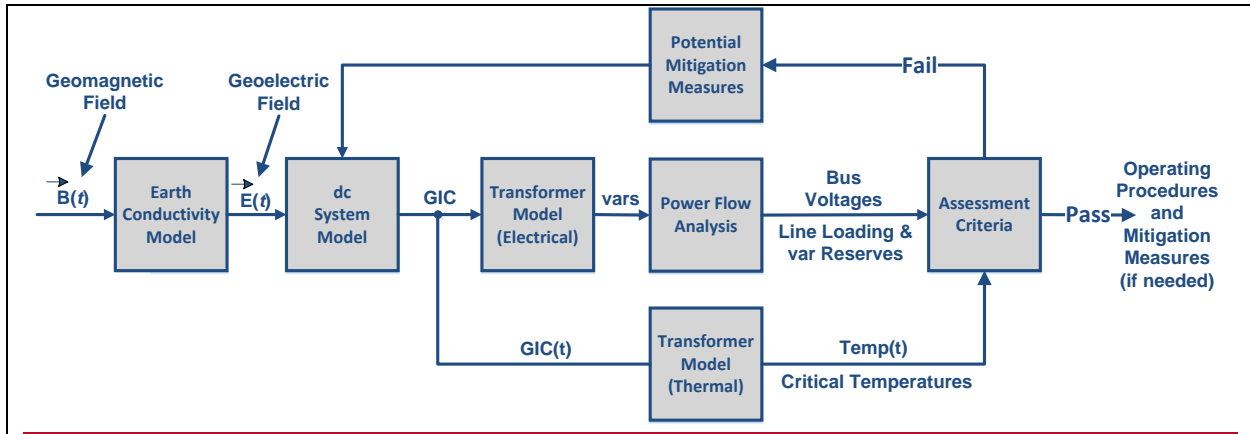


**Figure 7: Supplemental Geoelectric Field Waveform**  
**Blue  $E_N$  (Northward), Red  $E_E$  (Eastward)**



## Guidelines and Technical Basis

The diagram below provides an overall view of the GMD Vulnerability Assessment process:



The requirements in this standard cover various aspects of the GMD Vulnerability Assessment process.

### Benchmark GMD Event (Attachment 1)

The benchmark GMD event defines the goelectric field values used to compute GIC flows that are needed to conduct a benchmark GMD Vulnerability Assessment. The *Benchmark Geomagnetic Disturbance Event Description, May 2016*<sup>11</sup> A white paper ~~that~~ includes the event description, analysis, and example calculations ~~is available on the Project 2013-03 Geomagnetic Disturbance Mitigation project page.~~

### Supplemental GMD Event (Attachment 1)

The supplemental GMD event defines the goelectric field values used to compute GIC flows that are needed to conduct a supplemental GMD Vulnerability Assessment. The *Supplemental Geomagnetic Disturbance Event Description, October 2017*<sup>12</sup> white paper includes the event description and analysis.

### Requirement R2

A GMD Vulnerability Assessment requires a GIC System model, which is a dc representation of the System, to calculate GIC flow. In a GMD Vulnerability Assessment, GIC simulations are used to determine transformer Reactive Power absorption and transformer thermal response. Details for developing the GIC System model are provided in the NERC GMD Task Force guide:

<sup>11</sup> <http://www.nerc.com/pa/stand/Pages/TPL0071RI.aspx>.

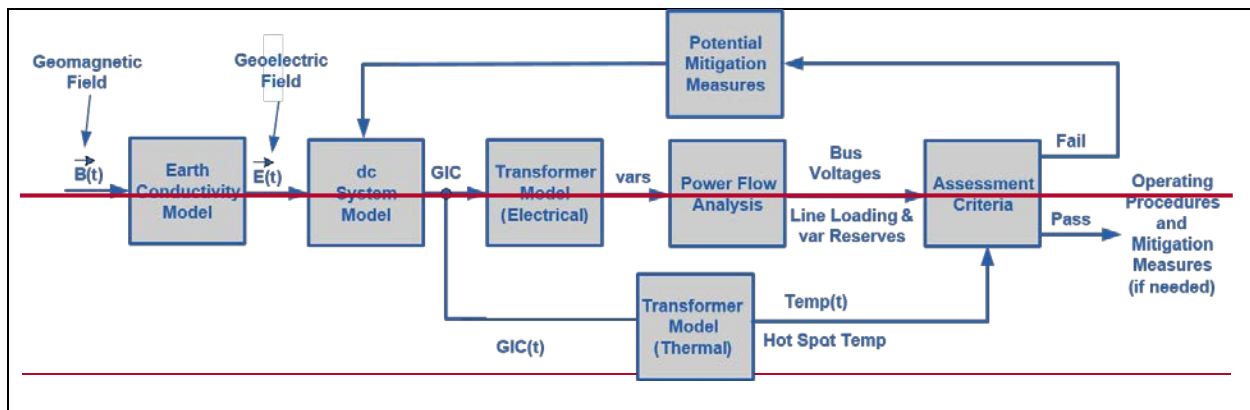
<sup>12</sup> <http://www.nerc.com/pa/Stand/Pages/Project-2013-03-Geomagnetic-Disturbance-Mitigation.aspx>.

*Application Guide for Computing Geomagnetically-Induced Current in the Bulk Power System, December 2013.*<sup>13</sup>

Underground pipe-type cables present a special modeling situation in that the steel pipe that encloses the power conductors significantly reduces the geoelectric field induced into the conductors themselves, while they remain a path for GIC. Solid dielectric cables that are not enclosed by a steel pipe will not experience a reduction in the induced geoelectric field. A planning entity should account for special modeling situations in the GIC system model, if applicable.

**Requirement R4**

The ~~Geomagnetic Disturbance GMD~~ *Planning Guide*,<sup>14</sup> December 2013 developed by the NERC GMD Task Force provides technical information on GMD-specific considerations for planning studies. ~~It is available at:~~



**Requirement R5**

The ~~benchmark transformer~~ thermal impact assessment of transformers specified in Requirement R6 is based on GIC information for the ~~Benchmark~~ GMD Event. This GIC information is determined by the planning entity through simulation of the GIC System model and must be provided to the entity responsible for conducting the thermal impact assessment. GIC information should be provided in accordance with Requirement R5 each time the GMD Vulnerability Assessment is performed since, by definition, the GMD Vulnerability Assessment includes a documented evaluation of susceptibility to localized equipment damage due to GMD.

The maximum effective GIC value provided in Part 5.1 is used for ~~the benchmark transformer~~ thermal impact assessment. Only those transformers that experience an effective GIC value of 75 A or greater per phase require evaluation in Requirement R6.

<sup>13</sup> [http://www.nerc.com/comm/PC/Geomagnetic%20Disturbance%20Task%20Force%20GMDTF%202013/GIC%20Application%20Guide%202013\\_approved.pdf](http://www.nerc.com/comm/PC/Geomagnetic%20Disturbance%20Task%20Force%20GMDTF%202013/GIC%20Application%20Guide%202013_approved.pdf).

<sup>14</sup> [http://www.nerc.com/comm/PC/Geomagnetic%20Disturbance%20Task%20Force%20GMDTF%202013/GMD%20Planning%20Guide\\_approved.pdf](http://www.nerc.com/comm/PC/Geomagnetic%20Disturbance%20Task%20Force%20GMDTF%202013/GMD%20Planning%20Guide_approved.pdf).

GIC(t) provided in Part 5.2 is used to convert the steady state GIC flows to time-series GIC data for the benchmark transformer thermal impact assessment of transformers. This information may be needed by one or more of the methods for performing a benchmark thermal impact assessment. Additional information is in the following section and the Transformer Thermal Impact Assessment White Paper, 15 October 2017~~thermal assessment whitepaper~~.

The peak GIC value of 75 Amps per phase has been shown through thermal modeling to be a conservative threshold below which the risk of exceeding known temperature limits established by technical organizations is low.

### **Requirement R6**

The benchmark thermal impact assessment of a power transformer may be based on manufacturer-provided GIC capability curves, thermal response simulation, thermal impact screening, or other technically justified means. Approaches for conducting the assessment are presented in the *Transformer Thermal Impact Assessment* ~~White Paper posted on the project page~~ ERO Enterprise-Endorsed Implementation Guidance<sup>16</sup> for this requirement. This ERO-Endorsed document is posted on the NERC Compliance Guidance<sup>17</sup> webpage.

Transformers are exempt from the benchmark thermal impact assessment requirement if the effective GIC value for the transformer is less than 75 A per phase, as determined by a GIC analysis of the System. Justification for this criterion is provided in the *Screening Criterion for Transformer Thermal Impact Assessment* ~~White Paper posted on the project page~~,<sup>18</sup> October 2017. A documented design specification exceeding this value is also a justifiable threshold criterion that exempts a transformer from Requirement R6.

The benchmark threshold criteria and its associated transformer thermal impact must be evaluated on the basis of effective GIC. Refer to the white papers for additional information.

### **Requirement R7**

Technical considerations for GMD mitigation planning, including operating and equipment strategies, are available in Chapter 5 of the Geomagnetic Disturbance GMD-Planning Guide,<sup>19</sup> December 2013. Additional information is available in the *2012 Special Reliability Assessment Interim Report: Effects of Geomagnetic Disturbances on the Bulk-Power System*,<sup>20</sup> February 2012.

---

<sup>15</sup> <http://www.nerc.com/pa/Stand/Pages/Project-2013-03-Geomagnetic-Disturbance-Mitigation.aspx>.

<sup>16</sup> [http://www.nerc.com/pa/comp/guidance/EROEndorsedImplementationGuidance/TPL-007-1\\_Transformer\\_Thermal\\_Impact\\_Assessment\\_White\\_Paper.pdf](http://www.nerc.com/pa/comp/guidance/EROEndorsedImplementationGuidance/TPL-007-1_Transformer_Thermal_Impact_Assessment_White_Paper.pdf).

<sup>17</sup> <http://www.nerc.com/pa/comp/guidance/Pages/default.aspx>.

<sup>18</sup> <http://www.nerc.com/pa/Stand/Pages/Project-2013-03-Geomagnetic-Disturbance-Mitigation.aspx>.

<sup>19</sup> [http://www.nerc.com/comm/PC/Geomagnetic%20Disturbance%20Task%20Force%20GMDTF%202013/GMD%20Planning%20Guide\\_approved.pdf](http://www.nerc.com/comm/PC/Geomagnetic%20Disturbance%20Task%20Force%20GMDTF%202013/GMD%20Planning%20Guide_approved.pdf).

<sup>20</sup> <http://www.nerc.com/pa/RAPA/ra/Reliability%20Assessments%20DL/2012GMD.pdf>.

**Requirement R8**

The *Geomagnetic Disturbance Planning Guide*,<sup>21</sup> December 2013 developed by the NERC GMD Task Force provides technical information on GMD-specific considerations for planning studies.

The supplemental GMD Vulnerability Assessment process is similar to the benchmark GMD Vulnerability Assessment process described under Requirement R4.

**Requirement R9**

The supplemental thermal impact assessment specified of transformers in Requirement R10 is based on GIC information for the supplemental GMD Event. This GIC information is determined by the planning entity through simulation of the GIC System model and must be provided to the entity responsible for conducting the thermal impact assessment. GIC information should be provided in accordance with Requirement R9 each time the GMD Vulnerability Assessment is performed since, by definition, the GMD Vulnerability Assessment includes a documented evaluation of susceptibility to localized equipment damage due to GMD.

The maximum effective GIC value provided in Part 9.1 is used for the supplemental thermal impact assessment. Only those transformers that experience an effective GIC value of 85 A or greater per phase require evaluation in Requirement R10.

GIC(t) provided in Part 9.2 is used to convert the steady state GIC flows to time-series GIC data for the supplemental thermal impact assessment of transformers. This information may be needed by one or more of the methods for performing a supplemental thermal impact assessment. Additional information is in the following section.

The peak GIC value of 85 Amps per phase has been shown through thermal modeling to be a conservative threshold below which the risk of exceeding known temperature limits established by technical organizations is low.

**Requirement R10**

The supplemental thermal impact assessment of a power transformer may be based on manufacturer-provided GIC capability curves, thermal response simulation, thermal impact screening, or other technically justified means. Approaches for conducting the assessment are presented in the *Transformer Thermal Impact Assessment White Paper ERO Enterprise-Endorsed Implementation Guidance*<sup>22</sup> discussed in the Requirement R6 section above. A later version of the *Transformer Thermal Impact Assessment White Paper*,<sup>23</sup> October 2017, has been developed to

---

<sup>21</sup> [http://www.nerc.com/comm/PC/Geomagnetic%20Disturbance%20Task%20Force%20GMDTF%202013/GMD%20Planning%20Guide\\_approved.pdf](http://www.nerc.com/comm/PC/Geomagnetic%20Disturbance%20Task%20Force%20GMDTF%202013/GMD%20Planning%20Guide_approved.pdf).

<sup>22</sup> [http://www.nerc.com/pa/comp/guidance/EROEndorsedImplementationGuidance/TPL-007-1\\_Transformer\\_Thermal\\_Impact\\_Assessment\\_White\\_Paper.pdf](http://www.nerc.com/pa/comp/guidance/EROEndorsedImplementationGuidance/TPL-007-1_Transformer_Thermal_Impact_Assessment_White_Paper.pdf).

<sup>23</sup> <http://www.nerc.com/pa/Stand/Pages/Project-2013-03-Geomagnetic-Disturbance-Mitigation.aspx>.

include updated information pertinent to the supplemental GMD event and supplemental thermal impact assessment.

Transformers are exempt from the supplemental thermal impact assessment requirement if the effective GIC value for the transformer is less than 85 A per phase, as determined by a GIC analysis of the System. Justification for this criterion is provided in the revised *Screening Criterion for Transformer Thermal Impact Assessment White Paper*,<sup>24</sup> October 2017. A documented design specification exceeding this value is also a justifiable threshold criterion that exempts a transformer from Requirement R10.

The supplemental threshold criteria and its associated transformer thermal impact must be evaluated on the basis of effective GIC. Refer to the white papers for additional information.

### **Requirement R11**

Technical considerations for GIC monitoring are contained in Chapter 6 of the *2012 Special Reliability Assessment Interim Report: Effects of Geomagnetic Disturbances on the Bulk-Power System*,<sup>25</sup> February 2012. GIC monitoring is generally performed by Hall effect transducers that are attached to the neutral of the wye-grounded transformer. Data from GIC monitors is useful for model validation and situational awareness.

Responsible entities consider the following in developing a process for obtaining GIC monitor data:

- **Monitor locations.** An entity's operating process may be constrained by location of existing GIC monitors. However, when planning for additional GIC monitoring installations consider that data from monitors located in areas found to have high GIC based on system studies may provide more useful information for validation and situational awareness purposes. Conversely, data from GIC monitors that are located in the vicinity of transportation systems using direct current (e.g., subways or light rail) may be unreliable.
- **Monitor specifications.** Capabilities of Hall effect transducers, existing and planned, should be considered in the operating process. When planning new GIC monitor installations, consider monitor data range (e.g., -500 A through + 500 A) and ambient temperature ratings consistent with temperatures in the region in which the monitor will be installed.
- **Sampling Interval.** An entity's operating process may be constrained by capabilities of existing GIC monitors. However, when possible specify data sampling during periods of interest at a rate of 10 seconds or faster.
- **Collection Periods.** The process should specify when the entity expects GIC data to be collected. For example, collection could be required during periods where the Kp index is

---

<sup>24</sup> <http://www.nerc.com/pa/Stand/Pages/Project-2013-03-Geomagnetic-Disturbance-Mitigation.aspx>.

<sup>25</sup> <http://www.nerc.com/pa/RAPA/ra/Reliability%20Assessments%20DL/2012GMD.pdf>.

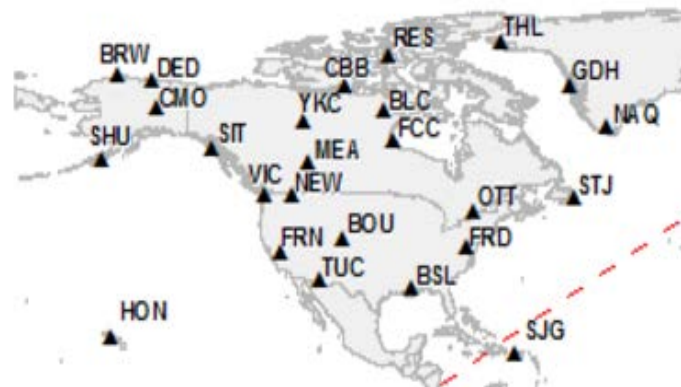
above a threshold, or when GIC values are above a threshold. Determining when to discontinue collecting GIC data should also be specified to maintain consistency in data collection.

- **Data format.** Specify time and value formats. For example, Greenwich Mean Time (GMT) (MM/DD/YYYY HH:MM:SS) and GIC Value (Ampere). Positive (+) and negative (-) signs indicate direction of GIC flow. Positive reference is flow from ground into transformer neutral. Time fields should indicate the sampled time rather than system or SCADA time if supported by the GIC monitor system.
- **Data retention.** The entity's process should specify data retention periods, for example 1 year. Data retention periods should be adequately long to support availability for the entity's model validation process and external reporting requirements, if any.
- **Additional information.** The entity's process should specify collection of other information necessary for making the data useful, for example monitor location and type of neutral connection (e.g., three-phase or single-phase).

### **Requirement R12**

Magnetometers measure changes in the earth's magnetic field. Entities should obtain data from the nearest accessible magnetometer. Sources of magnetometer data include:

- Observatories such as those operated by U.S. Geological Survey and Natural Resources Canada, see figure below for locations:<sup>26</sup>



- Research institutions and academic universities;
- Entities with installed magnetometers.

---

<sup>26</sup> <http://www.intermagnet.org/index-eng.php>.

Entities that choose to install magnetometers should consider equipment specifications and data format protocols contained in the latest version of the *INTERMAGNET Technical Reference Manual, Version 4.6, 2012.*<sup>27</sup>

## **Rationale**

During development of ~~TPL-007-1 this standard~~, text boxes were embedded within the standard to explain the rationale for various parts of the standard. ~~Upon BOT approval, t~~The text from the rationale text boxes was moved to this section upon approval of TPL-007-1 by the NERC Board of Trustees. In developing TPL-007-2, the SDT has made changes to the sections below only when necessary for clarity. Changes are marked with brackets [ ].

### **Rationale for Applicability:**

Instrumentation transformers and station service transformers do not have significant impact on geomagnetically-induced current (GIC) flows; therefore, these transformers are not included in the applicability for this standard.

Terminal voltage describes line-to-line voltage.

### **Rationale for R1:**

In some areas, planning entities may determine that the most effective approach to conduct a GMD Vulnerability Assessment is through a regional planning organization. No requirement in the standard is intended to prohibit a collaborative approach where roles and responsibilities are determined by a planning organization made up of one or more Planning Coordinator(s).

### **Rationale for R2:**

A GMD Vulnerability Assessment requires a GIC System model to calculate GIC flow which is used to determine transformer Reactive Power absorption and transformer thermal response. Guidance for developing the GIC System model is provided in the ~~GIC Application Guide~~ *Computing Geomagnetically-Induced Current in the Bulk-Power System*,<sup>28</sup> December 2013, developed by the NERC GMD Task Force ~~and available at:~~

The System model specified in Requirement R2 is used in conducting steady state power flow analysis that accounts for the Reactive Power absorption of power transformer(s) due to GIC in the System.

The GIC System model includes all power transformer(s) with a high side, wye-grounded winding with terminal voltage greater than 200 kV. The model is used to calculate GIC flow in the network.

---

<sup>27</sup> [http://www.intermagnet.org/publications/intermag\\_4-6.pdf](http://www.intermagnet.org/publications/intermag_4-6.pdf).

<sup>28</sup> [http://www.nerc.com/comm/PC/Geomagnetic%20Disturbance%20Task%20Force%20GMDTF%202013/GIC%20Application%20Guide%202013\\_approved.pdf](http://www.nerc.com/comm/PC/Geomagnetic%20Disturbance%20Task%20Force%20GMDTF%202013/GIC%20Application%20Guide%202013_approved.pdf).

The projected System condition for GMD planning may include adjustments to the System that are executable in response to space weather information. These adjustments could include, for example, recalling or postponing maintenance outages.

The Violation Risk Factor (VRF) for Requirement R2 is changed from Medium to High. This change is for consistency with the VRF for approved standard TPL-001-4 Requirement R1, which is proposed for revision in the NERC filing dated August 29, 2014 ([Docket No. RM12-1-000](#)). NERC guidelines require consistency among Reliability Standards.

**Rationale for R3:**

Requirement R3 allows a responsible entity the flexibility to determine the System steady state voltage criteria for System steady state performance in Table 1. Steady state voltage limits are an example of System steady state performance criteria.

**Rationale for R4:**

The GMD Vulnerability Assessment includes steady state power flow analysis and the supporting study or studies using the models specified in Requirement R2 that account for the effects of GIC. Performance criteria are specified in Table 1.

At least one System On-Peak Load and at least one System Off-Peak Load must be examined in the analysis.

Distribution of GMD Vulnerability Assessment results provides a means for sharing relevant information with other entities responsible for planning reliability. Results of GIC studies may affect neighboring systems and should be taken into account by planners.

The [Geomagnetic Disturbance GMD-Planning Guide](#),<sup>29</sup> [December 2013](#) developed by the NERC GMD Task Force provides technical information on GMD-specific considerations for planning studies. ~~It is available at:~~ The provision of information in Requirement R4, Part 4.3, shall be subject to the legal and regulatory obligations for the disclosure of confidential and/or sensitive information.

**Rationale for R5:**

This GIC information is necessary for determining the thermal impact of GIC on transformers in the planning area and must be provided to entities responsible for performing the thermal impact assessment so that they can accurately perform the assessment. GIC information should be provided in accordance with Requirement R5 as part of the GMD Vulnerability Assessment process since, by definition, the GMD Vulnerability Assessment includes documented evaluation of susceptibility to localized equipment damage due to GMD.

The maximum effective GIC value provided in Part 5.1 is used for transformer thermal impact assessment.

---

<sup>29</sup> [http://www.nerc.com/comm/PC/Geomagnetic%20Disturbance%20Task%20Force%20GMDTF%202013/GMD%20Planning%20Guide\\_approved.pdf](http://www.nerc.com/comm/PC/Geomagnetic%20Disturbance%20Task%20Force%20GMDTF%202013/GMD%20Planning%20Guide_approved.pdf).



GIC(t) provided in Part 5.2 can alternatively be used to convert the steady state GIC flows to time-series GIC data for transformer thermal impact assessment. This information may be needed by one or more of the methods for performing a thermal impact assessment. Additional guidance is available in the *Transformer Thermal Impact Assessment ~~White Paper~~*,<sup>30</sup> October 2017.

A Transmission Owner or Generator Owner that desires GIC(t) may request it from the planning entity. The planning entity shall provide GIC(t) upon request once GIC has been calculated, but no later than 90 calendar days after receipt of a request from the owner and after completion of Requirement R5, Part 5.1.

The provision of information in Requirement R5 shall be subject to the legal and regulatory obligations for the disclosure of confidential and/or sensitive information.

**Rationale for R6:**

The transformer thermal impact screening criterion has been revised from 15 A per phase to 75 A per phase [for the benchmark GMD event]. Only those transformers that experience an effective GIC value of 75 A per phase or greater require evaluation in Requirement R6. The justification is provided in the *Screening Criterion for Transformer Thermal Impact Assessment White Paper*,<sup>31</sup> October 2017~~white paper~~.

The thermal impact assessment may be based on manufacturer-provided GIC capability curves, thermal response simulation, thermal impact screening, or other technically justified means. The transformer thermal assessment will be repeated or reviewed using previous assessment results each time the planning entity performs a GMD Vulnerability Assessment and provides GIC information as specified in Requirement R5. Approaches for conducting the assessment are presented in the *Transformer Thermal Impact Assessment White Paper*,<sup>32</sup> October 2017.

Thermal impact assessments are provided to the planning entity, as determined in Requirement R1, so that identified issues can be included in the GMD Vulnerability Assessment (R4), and the Corrective Action Plan (R7) as necessary.

Thermal impact assessments of non-BES transformers are not required because those transformers do not have a wide-area effect on the reliability of the interconnected Transmission system.

The provision of information in Requirement R6, Part 6.4, shall be subject to the legal and regulatory obligations for the disclosure of confidential and/or sensitive information.

---

<sup>30</sup> <http://www.nerc.com/pa/Stand/Pages/Project-2013-03-Geomagnetic-Disturbance-Mitigation.aspx>.

<sup>31</sup> <http://www.nerc.com/pa/Stand/Pages/Project-2013-03-Geomagnetic-Disturbance-Mitigation.aspx>.

<sup>32</sup> <http://www.nerc.com/pa/Stand/Pages/Project-2013-03-Geomagnetic-Disturbance-Mitigation.aspx>.

**Rationale for R7:**

Corrective Action Plans are defined in the NERC Glossary of Terms:

*A list of actions and an associated timetable for implementation to remedy a specific problem.*

Corrective Action Plans must, subject to the vulnerabilities identified in the assessments, contain strategies for protecting against the potential impact of the Benchmark GMD event, based on factors such as the age, condition, technical specifications, system configuration, or location of specific equipment. Chapter 5 of the NERC GMD Task Force *Geomagnetic Disturbance GMD Planning Guide*,<sup>33</sup> December 2013 provides a list of mitigating measures that may be appropriate to address an identified performance issue.

The provision of information in Requirement R7, Part 7.3 [Part 7.5 in TPL-007-2], shall be subject to the legal and regulatory obligations for the disclosure of confidential and/or sensitive information.

**Rationale for Table 3:**

Table 3 has been revised to use the same ground model designation, FL1, as is being used by USGS. The calculated scaling factor for FL1 is 0.74. [The scaling factor associated with the benchmark GMD event for the Florida earth model (FL1) has been updated to 0.76 in TPL-007-2 based on the earth model published on the USGS public website.]

---

<sup>33</sup> [http://www.nerc.com/comm/PC/Geomagnetic%20Disturbance%20Task%20Force%20GMDTF%202013/GMD%20Planning%20Guide\\_approved.pdf](http://www.nerc.com/comm/PC/Geomagnetic%20Disturbance%20Task%20Force%20GMDTF%202013/GMD%20Planning%20Guide_approved.pdf).

**Exhibit B**

**Implementation Plan for Proposed Reliability Standard TPL-007-2**

# Implementation Plan

## Project 2013-03 Geomagnetic Disturbance Mitigation Reliability Standard TPL-007-2

### Applicable Standard

- TPL-007-2 - Transmission System Planned Performance for Geomagnetic Disturbance Events

### Requested Retirement

- TPL-007-1 - Transmission System Planned Performance for Geomagnetic Disturbance Events

### Prerequisite Standard

None

### Applicable Entities

- *Planning Coordinator with a planning area that includes a Facility or Facilities specified in Section 4.2 of the standard;*
- *Transmission Planner with a planning area that includes a Facility or Facilities specified in Section 4.2 of the standard;*
- *Transmission Owner who owns a Facility or Facilities specified in Section 4.2 of the standard; and*
- *Generator Owner who owns a Facility or Facilities specified in Section 4.2 of the standard.*

Section 4.2 states that the standard applies to facilities that include power transformer(s) with a high-side, wye-grounded winding with terminal voltage greater than 200 kV.

### Terms in the NERC Glossary of Terms

There are no new, modified, or retired terms.

### Background

On September 22, 2016, the Federal Energy Regulatory Commission (FERC) issued Order No. 830 approving Reliability Standard TPL-007-1 and its associated five-year Implementation Plan. In the Order, FERC also directed NERC to develop certain modifications to the standard. FERC established a deadline of 18 months from the effective date of Order No. 830 for completing the revisions, which is May 2018.

### General Considerations

This Implementation Plan is intended to integrate the new requirements in TPL-007-2 with the GMD Vulnerability Assessment process that is being implemented through approved TPL-007-1. At the time of the May 2018 filing deadline, many requirements in approved standard TPL-007-1 that lead

to completion of the geomagnetic disturbance (GMD) Vulnerability Assessment will be in effect. Furthermore, many entities may be taking steps to complete studies or assessments that are required by future enforceable requirements in TPL-007-1. The Implementation Plan phases in the requirements in TPL-007-2 based on the effective date of TPL-007-2, as follows:

- **Effective Date before January 1, 2021.** Implementation timeline supports applicable entities completing new requirements for supplemental GMD Vulnerability Assessments concurrently with requirements for the benchmark GMD Vulnerability Assessment (concurrent effective dates).
- **Effective Date on or after January 1, 2021.** Implementation timeline supports applicable entities completing the benchmark GMD Vulnerability Assessments before new requirements for supplemental GMD Vulnerability Assessments become effective.

### **Effective Date**

The effective date for the proposed Reliability Standard is provided below. Where the standard drafting team identified the need for a longer implementation period for compliance with a particular section of the proposed Reliability Standard (e.g., an entire Requirement or a portion thereof), the additional time for compliance with that section is specified below. These phased-in compliance dates represent the dates that entities must begin to comply with that particular section of the Reliability Standard, even where the Reliability Standard goes into effect at an earlier date.

### **Standard TPL-007-2**

Where approval by an applicable governmental authority is required, the standard shall become effective on the first day of the first calendar quarter that is three (3) months after the effective date of the applicable governmental authority's order approving the standard, or as otherwise provided for by the applicable governmental authority.

Where approval by an applicable governmental authority is not required, the standard shall become effective on the first day of the first calendar quarter that is three (3) months after the date the standard is adopted by the NERC Board of Trustees, or as otherwise provided for in that jurisdiction.

### **Phased-In Compliance Dates**

#### ***If TPL-007-2 becomes effective before January 1, 2021***

Implementation timeline supports applicable entities completing new requirements for supplemental GMD Vulnerability Assessments concurrently with requirements for the benchmark GMD Vulnerability Assessment (concurrent effective dates).

### **Compliance Date for TPL-007-2 Requirements R1 and R2**

Entities shall be required to comply with Requirements R1 and R2 upon the effective date of Reliability Standard TPL-007-2.

**Compliance Date for TPL-007-2 Requirement R5**

Entities shall not be required to comply with Requirements R5 until six (6) months after the effective date of Reliability Standard TPL-007-2.

**Compliance Date for TPL-007-2 Requirement R9**

Entities shall not be required to comply with Requirement R9 until six (6) months after the effective date of Reliability Standard TPL-007-2.

**Compliance Date for TPL-007-2 Requirements R11 and R12**

Entities shall not be required to comply with Requirements R11 and R12 until 24 months after the effective date of Reliability Standard TPL-007-2.

**Compliance Date for TPL-007-2 Requirements R6 and R10**

Entities shall not be required to comply with Requirements R6 and R10 until 30 months after the effective date of Reliability Standard TPL-007-2.

**Compliance Date for TPL-007-2 Requirements R3, R4, and R8**

Entities shall not be required to comply with Requirements R3, R4, and R8 until 42 months after the effective date of Reliability Standard TPL-007-2.

**Compliance Date for TPL-007-2 Requirement R7**

Entities shall not be required to comply with Requirement R7 until 54 months after the effective date of Reliability Standard TPL-007-2.

*If TPL-007-2 becomes effective on or after January 1, 2021*

Implementation timeline supports applicable entities completing the benchmark GMD Vulnerability Assessments before new requirements for supplemental GMD Vulnerability Assessments become effective.

**Compliance Date for TPL-007-2 Requirements R1, R2, R5, and R6**

Entities shall be required to comply with Requirements R1, R2, R5, and R6 upon the effective date of Reliability Standard TPL-007-2.

**Compliance Date for TPL-007-2 Requirements R3 and R4**

Entities shall not be required to comply with Requirements R3 and R4 until 12 months after the effective date of Reliability Standard TPL-007-2.

**Compliance Date for TPL-007-2 Requirements R7, R11, and R12**

Entities shall not be required to comply with Requirements R7, R11, and R12 until 24 months after the effective date of Reliability Standard TPL-007-2.

**Compliance Date for TPL-007-2 Requirement R9**

Entities shall not be required to comply with Requirement R9 until 36 months after the effective date of Reliability Standard TPL-007-2.

**Compliance Date for TPL-007-2 Requirement R10**

Entities shall not be required to comply with Requirement R10 until 60 months after the effective date of Reliability Standard TPL-007-2.

**Compliance Date for TPL-007-2 Requirement R8**

Entities shall not be required to comply with Requirement R8 until 72 months after the effective date of Reliability Standard TPL-007-2.

**Retirement Date**

**Standard TPL-007-1**

Reliability Standard TPL-007-1 shall be retired immediately prior to the effective date of TPL-007-2 in the particular jurisdiction in which the revised standard is becoming effective.

**Initial Performance of Periodic Requirements**

Transmission Owners and Generator Owners are not required to comply with Requirement R6 prior to the compliance date for Requirement R6, regardless of when geomagnetically-induced current (GIC) flow information specified in Requirement R5, Part 5.1 is received.

Transmission Owners and Generator Owners are not required to comply with Requirement R10 prior to the compliance date for Requirement R10, regardless of when GIC flow information specified in Requirement R9, Part 9.1 is received.

## **Exhibit C**

### **Analysis of Violation Risk Factors and Violations Severity Levels**



# Violation Risk Factor and Violation Severity Level

## Justifications

### TPL-007-2 – Transmission System Planned Performance for Geomagnetic Disturbance Events

This document provides the Standard Drafting Team's (SDT) justification for assignment of Violation Risk Factors (VRFs) and Violation Severity Levels (VSLs) for each requirement in TPL-007-2 – Transmission System Planned Performance for Geomagnetic Disturbance Events. Each requirement is assigned a VRF and a VSL. These elements support the determination of an initial value range for the Base Penalty Amount regarding violations of requirements in FERC-approved Reliability Standards, as defined in the ERO Sanction Guidelines. The SDT applied the following NERC criteria and FERC Guidelines when proposing VRFs and VSLs for the requirements under this project.

### NERC Criteria - Violation Risk Factors

#### High Risk Requirement

A requirement that, if violated, could directly cause or contribute to Bulk Electric System instability, separation, or a cascading sequence of failures, or could place the Bulk Electric System at an unacceptable risk of instability, separation, or cascading failures; or, a requirement in a planning time frame that, if violated, could, under emergency, abnormal, or restorative conditions anticipated by the preparations, directly cause or contribute to Bulk Electric System instability, separation, or a cascading sequence of failures, or could place the Bulk Electric System at an unacceptable risk of instability, separation, or cascading failures, or could hinder restoration to a normal condition.

#### Medium Risk Requirement

A requirement that, if violated, could directly affect the electrical state or the capability of the Bulk Electric System, or the ability to effectively monitor and control the Bulk Electric System. However, violation of a medium risk requirement is unlikely to lead to Bulk Electric System instability, separation, or cascading failures; or, a requirement in a planning time frame that, if violated, could, under emergency, abnormal, or restorative conditions anticipated by the preparations, directly and adversely affect the electrical state or capability of the Bulk Electric System, or the ability to effectively monitor, control, or restore the Bulk Electric System. However, violation of a medium risk requirement is unlikely, under emergency, abnormal, or restoration conditions anticipated by the preparations, to lead to Bulk Electric System instability, separation, or cascading failures, nor to hinder restoration to a normal condition.

### **Lower Risk Requirement**

A requirement that is administrative in nature and a requirement that, if violated, would not be expected to adversely affect the electrical state or capability of the Bulk Electric System, or the ability to effectively monitor and control the Bulk Electric System; or, a requirement that is administrative in nature and a requirement in a planning time frame that, if violated, would not, under the emergency, abnormal, or restorative conditions anticipated by the preparations, be expected to adversely affect the electrical state or capability of the Bulk Electric System, or the ability to effectively monitor, control, or restore the Bulk Electric System.

## **FERC Violation Risk Factor Guidelines**

### **Guideline (1) – Consistency with the Conclusions of the Final Blackout Report**

The Commission seeks to ensure that VRFs assigned to Requirements of Reliability Standards in these identified areas appropriately reflect their historical critical impact on the reliability of the Bulk-Power System. In the VSL Order, FERC listed critical areas (from the Final Blackout Report) where violations could severely affect the reliability of the Bulk-Power System:

- Emergency operations
- Vegetation management
- Operator personnel training
- Protection systems and their coordination
- Operating tools and backup facilities
- Reactive power and voltage control
- System modeling and data exchange
- Communication protocol and facilities
- Requirements to determine equipment ratings
- Synchronized data recorders

- Clearer criteria for operationally critical facilities
- Appropriate use of transmission loading relief.

**Guideline (2) – Consistency within a Reliability Standard**

The Commission expects a rational connection between the sub-Requirement VRF assignments and the main Requirement VRF assignment.

**Guideline (3) – Consistency among Reliability Standards**

The Commission expects the assignment of VRFs corresponding to requirements that address similar reliability goals in different Reliability Standards would be treated comparably.

**Guideline (4) – Consistency with NERC’s Definition of the Violation Risk Factor Level**

Guideline (4) was developed to evaluate whether the assignment of a particular VRF level conforms to NERC’s definition of that risk level.

**Guideline (5) – Treatment of Requirements that Co-mingle More Than One Obligation**

Where a single Requirement co-mingles a higher risk reliability objective and a lesser risk reliability objective, the VRF assignment for such requirements must not be watered down to reflect the lower risk level associated with the less important objective of the Reliability Standard.

**NERC Criteria - Violation Severity Levels**

VSLs define the degree to which compliance with a requirement was not achieved. Each requirement must have at least one VSL. While it is preferable to have four VSLs for each requirement, some requirements do not have multiple “degrees” of noncompliant performance and may have only one, two, or three VSLs.

VSLs should be based on NERC’s overarching criteria shown in the table below:

Lower VSL	Moderate VSL	High VSL	Severe VSL
The performance or product measured almost meets the full intent of the requirement.	The performance or product measured meets the majority of the intent of the requirement.	The performance or product measured does not meet the majority of the intent of the requirement, but does meet some of the intent.	The performance or product measured does not substantively meet the intent of the requirement.

**FERC Order of Violation Severity Levels**

FERC’s VSL guidelines are presented below, followed by an analysis of whether the VSLs proposed for each requirement in the standard meet the FERC Guidelines for assessing VSLs:

**Guideline 1 – Violation Severity Level Assignments Should Not Have the Unintended Consequence of Lowering the Current Level of Compliance**

Compare the VSLs to any prior levels of non-compliance and avoid significant changes that may encourage a lower level of compliance than was required when levels of non-compliance were used.

**Guideline 2 – Violation Severity Level Assignments Should Ensure Uniformity and Consistency in the Determination of Penalties**

A violation of a “binary” type requirement must be a “Severe” VSL.  
Do not use ambiguous terms such as “minor” and “significant” to describe noncompliant performance.

**Guideline 3 – Violation Severity Level Assignment Should Be Consistent with the Corresponding Requirement**

VSLs should not expand on what is required in the requirement.

**Guideline 4 – Violation Severity Level Assignment Should Be Based on A Single Violation, Not on A Cumulative Number of Violations**

Unless otherwise stated in the requirement, each instance of non-compliance with a requirement is a separate violation. Section 4 of the Sanction Guidelines states that assessing penalties on a per-violation per-day basis is the “default” for penalty calculations.

<b>VRF Justifications – TPL-007-2, R1</b>	
<b>Proposed VRF</b>	<b>Low</b>
FERC VRF G1 Discussion	Guideline 1- Consistency w/ Blackout Report. N/A
FERC VRF G2 Discussion	Guideline 2- Consistency within a Reliability Standard. The requirement has no sub-requirements so a single VRF was assigned.
FERC VRF G3 Discussion	Guideline 3- Consistency among Reliability Standards. A VRF of Lower is consistent with Reliability Standard TPL-001-4 Requirement R7, which requires the Planning Coordinator, in conjunction with each of its Transmission Planners, to identify each entity’s individual and joint responsibilities for performing required studies for the Planning Assessment. Proposed TPL-007-2 Requirement R1 requires Planning Coordinators, in conjunction with Transmission Planners, to identify individual and joint responsibilities for maintaining models and performing studies needed to complete the benchmark and supplemental GMD Vulnerability Assessments, and implementing process(es) to obtain GMD measurement data as specified in the Standard.
FERC VRF G4 Discussion	Guideline 4- Consistency with NERC Definitions of VRFs. A VRF of Lower is consistent with the NERC VRF definition. The requirement for identifying individual and joint responsibilities of the Planning Coordinator and each of the Transmission Planners in the Planning Coordinator’s planning area for maintaining models, performing GMD studies, and obtaining GMD measurement data, if violated, would not be expected to adversely affect the electrical state or capability of the Bulk Electric System, or the ability to effectively monitor, control, or restore the Bulk Electric System under conditions of a GMD event.

## VRF Justifications – TPL-007-2, R1

Proposed VRF	Low
FERC VRF G5 Discussion	Guideline 5- Treatment of Requirements that Co-mingle More than One Obligation. The requirement contains one objective, therefore a single VRF is assigned.

Proposed VSLs – TPL-007-2, R1			
Lower	Moderate	High	Severe
N/A	N/A	N/A	The Planning Coordinator, in conjunction with its Transmission Planner(s), failed to determine and identify individual or joint responsibilities of the Planning Coordinator and Transmission Planner(s) in the Planning Coordinator’s planning area for maintaining models, performing the study or studies needed to complete benchmark and supplemental GMD Vulnerability Assessments, and implementing process(es) to obtain GMD measurement data as specified in this standard.

VSL Justifications – TPL-007-2, R1	
NERC VSL Guidelines	Consistent with NERC's VSL Guidelines. The requirement does not have elements or quantities to evaluate degrees of compliance. A VSL of Severe is assigned for non-compliance.
FERC VSL G1 Violation Severity Level Assignments Should Not Have the Unintended Consequence of Lowering the Current Level of Compliance	The VSL is not changed in TPL-007-2.
FERC VSL G2 Violation Severity Level Assignments Should Ensure Uniformity and Consistency in the Determination of Penalties Guideline 2a: The Single Violation Severity Level Assignment Category for "Binary" Requirements Is Not Consistent Guideline 2b: Violation Severity Level Assignments that Contain Ambiguous Language	The proposed VSL is written to ensure uniformity and consistency in the determination of penalties.  Guideline 2a: The proposed VSL is binary and assigned a Severe VSL.  Guideline 2b: The proposed VSL does not use ambiguous terms, supporting uniformity and consistency in the determination of similar penalties for similar violations.
FERC VSL G3 Violation Severity Level Assignment Should Be	The proposed VSL is worded consistently with the corresponding requirement.



<p>Consistent with the Corresponding Requirement</p>	
<p>FERC VSL G4 Violation Severity Level Assignment Should Be Based on A Single Violation, Not on A Cumulative Number of Violations</p>	<p>The proposed VSL is not based on a cumulative number of violations.</p>

<b>VRF Justifications – TPL-007-2, R2</b>	
<b>Proposed VRF</b>	<b>High</b>
FERC VRF G1 Discussion	Guideline 1- Consistency w/ Blackout Report: N/A
FERC VRF G2 Discussion	Guideline 2- Consistency within a Reliability Standard: The requirement has no sub-requirements so a single VRF was assigned.
FERC VRF G3 Discussion	Guideline 3- Consistency among Reliability Standards. A VRF of High is consistent with the VRF for Reliability Standard TPL-001-4 Requirement R1 as amended in NERC's filing dated August 29, 2014, which requires Transmission Planners and Planning Coordinators to maintain models within its respective planning area for performing studies needed to complete its Planning Assessment. Proposed TPL-007-2, Requirement R2 requires responsible entities to maintain System models and GIC System models of the responsible entity's planning area for performing the studies needed to complete benchmark and supplemental GMD Vulnerability Assessments.
FERC VRF G4 Discussion	Guideline 4- Consistency with NERC Definitions of VRFs. The VRF of High is consistent with the NERC VRF Definition. The System Models and GIC System Models serve as the foundation for all conditions and events that are required to be studied and evaluated in the benchmark and supplemental GMD Vulnerability Assessments. For this reason, failure to maintain models of the responsible entity's planning area for performing GMD studies could, under GMD conditions that are as severe as the benchmark and supplemental GMD event, place the Bulk Electric System at an unacceptable risk of instability, separation, or cascading failures.
FERC VRF G5 Discussion	Guideline 5- Treatment of Requirements that Co-mingle More than One Obligation. This requirement does not co-mingle a higher-risk reliability objective with a lesser- risk reliability objective.

Proposed VSLs – TPL-007-2, R2			
Lower	Moderate	High	Severe
N/A	N/A	The responsible entity did not maintain either System models or GIC System models of the responsible entity’s planning area for performing the studies needed to complete benchmark and supplemental GMD Vulnerability Assessments.	The responsible entity did not maintain both System models and GIC System models of the responsible entity’s planning area for performing the studies needed to complete benchmark and supplemental GMD Vulnerability Assessments.

VSL Justifications – TPL-007-2, R2	
NERC VSL Guidelines	Consistent with NERC's VSL Guidelines. The requirement may be described by elements or quantities to evaluate degrees of compliance. Two VSLs are specified for a graduated scale.
FERC VSL G1 Violation Severity Level Assignments Should Not Have the Unintended Consequence of Lowering the Current Level of Compliance	The VSL is not changed in TPL-007-2.

VSL Justifications – TPL-007-2, R2	
<p>FERC VSL G2 Violation Severity Level Assignments Should Ensure Uniformity and Consistency in the Determination of Penalties Guideline 2a: The Single Violation Severity Level Assignment Category for "Binary" Requirements Is Not Consistent Guideline 2b: Violation Severity Level Assignments that Contain Ambiguous Language</p>	<p>The proposed VSL is written to ensure uniformity and consistency in the determination of penalties.</p> <p>Guideline 2a: The proposed VSL is not binary.</p> <p>Guideline 2b: The proposed VSL does not use ambiguous terms, supporting uniformity and consistency in the determination of similar penalties for similar violations.</p>
<p>FERC VSL G3 Violation Severity Level Assignment Should Be Consistent with the Corresponding Requirement</p>	<p>The proposed VSL is worded consistently with the corresponding requirement.</p>
<p>FERC VSL G4 Violation Severity Level Assignment Should Be Based on A Single Violation, Not on A Cumulative Number of Violations</p>	<p>The proposed VSL is not based on a cumulative number of violations.</p>

<b>VRF Justifications – TPL-007-2, R3</b>	
<b>Proposed VRF</b>	<b>Medium</b>
FERC VRF G1 Discussion	Guideline 1- Consistency w/ Blackout Report: N/A
FERC VRF G2 Discussion	Guideline 2- Consistency within a Reliability Standard: The requirement has no sub-requirements so a single VRF was assigned.
FERC VRF G3 Discussion	Guideline 3- Consistency among Reliability Standards. A VRF of Medium is consistent with Reliability Standard TPL-001-4 Requirement R5 which requires Transmission Planners and Planning Coordinators to have criteria for acceptable System steady state voltage limits. Proposed TPL-007-2 Requirement R4 requires responsible entities to have criteria for acceptable System steady state voltage performance for its System during the benchmark GMD event; these criteria may be different from the voltage limits determined in Reliability Standard TPL-001-4 Requirement R5.
FERC VRF G4 Discussion	Guideline 4- Consistency with NERC Definitions of VRFs. The VRF of Medium is consistent with the NERC VRF Definition. Failure to have criteria for acceptable System steady state voltage limits for its System during a GMD planning event could directly and adversely affect the electrical state or capability of the Bulk Electric System, or the ability to effectively monitor, control, or restore the Bulk Electric System during an actual GMD event. However, it is unlikely that such a failure by itself would lead to Bulk Electric System instability, separation, or cascading.
FERC VRF G5 Discussion	Guideline 5- Treatment of Requirements that Co-mingle More than One Obligation. This requirement does not co-mingle a higher-risk reliability objective with a lesser- risk reliability objective.

Proposed VSLs – TPL-007-2, R3			
Lower	Moderate	High	Severe
N/A	N/A	N/A	The responsible entity did not have criteria for acceptable System steady state voltage performance for its System during the GMD events described in Attachment 1 as required.

VSL Justifications – TPL-007-2, R3	
NERC VSL Guidelines	Consistent with NERC's VSL Guidelines. The requirement does not have elements or quantities to evaluate degrees of compliance. A VSL of Severe is assigned for non-compliance.
FERC VSL G1 Violation Severity Level Assignments Should Not Have the Unintended Consequence of Lowering the Current Level of Compliance	The VSL is not changed in TPL-007-2.

VSL Justifications – TPL-007-2, R3	
<p>FERC VSL G2 Violation Severity Level Assignments Should Ensure Uniformity and Consistency in the Determination of Penalties Guideline 2a: The Single Violation Severity Level Assignment Category for "Binary" Requirements Is Not Consistent Guideline 2b: Violation Severity Level Assignments that Contain Ambiguous Language</p>	<p>The proposed VSL is written to ensure uniformity and consistency in the determination of penalties.</p> <p>Guideline 2a: The proposed VSL is binary and assigned a Severe VSL.</p> <p>Guideline 2b: The proposed VSL does not use ambiguous terms, supporting uniformity and consistency in the determination of similar penalties for similar violations.</p>
<p>FERC VSL G3 Violation Severity Level Assignment Should Be Consistent with the Corresponding Requirement</p>	<p>The proposed VSL is worded consistently with the corresponding requirement.</p>
<p>FERC VSL G4 Violation Severity Level Assignment Should Be Based on A Single Violation, Not on A Cumulative Number of Violations</p>	<p>The proposed VSL is not based on a cumulative number of violations.</p>

<b>VRF Justifications – TPL-007-2, R4</b>	
<b>Proposed VRF</b>	<b>High</b>
FERC VRF G1 Discussion	Guideline 1- Consistency w/ Blackout Report: N/A
FERC VRF G2 Discussion	Guideline 2- Consistency within a Reliability Standard: The requirement has no sub-requirements so a single VRF was assigned.
FERC VRF G3 Discussion	Guideline 3- Consistency among Reliability Standards. A VRF of High is consistent with Reliability Standard TPL-001-4 Requirement R2 which requires Transmission Planners and Planning Coordinators to prepare an annual Planning Assessment to ensure its portion of the Bulk Electric System meets performance criteria. Proposed TPL-007-2 Requirement R4 requires responsible entities to complete a benchmark GMD Vulnerability Assessment to ensure the system meets performance criteria during the benchmark GMD event.
FERC VRF G4 Discussion	Guideline 4- Consistency with NERC Definitions of VRFs. The VRF of High is consistent with the NERC VRF Definition. Failure to complete a benchmark GMD Vulnerability Assessment could, under GMD conditions that are as severe as the benchmark GMD event, place the Bulk Electric System at an unacceptable risk of instability, separation, or cascading failures.
FERC VRF G5 Discussion	Guideline 5- Treatment of Requirements that Co-mingle More than One Obligation. This requirement does not co-mingle a higher-risk reliability objective with a lesser- risk reliability objective.



<b>Proposed VSLs – TPL-007-2, R4</b>			
<b>Lower</b>	<b>Moderate</b>	<b>High</b>	<b>Severe</b>
<p>The responsible entity completed a benchmark GMD Vulnerability Assessment, but it was more than 60 calendar months and less than or equal to 64 calendar months since the last benchmark GMD Vulnerability Assessment.</p>	<p>The responsible entity's completed benchmark GMD Vulnerability Assessment failed to satisfy one of the elements listed in Requirement R4, Parts 4.1 through 4.3;</p> <p>OR</p> <p>The responsible entity completed a benchmark GMD Vulnerability Assessment, but it was more than 64 calendar months and less than or equal to 68 calendar months since the last benchmark GMD Vulnerability Assessment.</p>	<p>The responsible entity's completed benchmark GMD Vulnerability Assessment failed to satisfy two of the elements listed in Requirement R4, Parts 4.1 through 4.3;</p> <p>OR</p> <p>The responsible entity completed a benchmark GMD Vulnerability Assessment, but it was more than 68 calendar months and less than or equal to 72 calendar months since the last benchmark GMD Vulnerability Assessment.</p>	<p>The responsible entity's completed benchmark GMD Vulnerability Assessment failed to satisfy three of the elements listed in Requirement R4, Parts 4.1 through 4.3;</p> <p>OR</p> <p>The responsible entity completed a benchmark GMD Vulnerability Assessment, but it was more than 72 calendar months since the last benchmark GMD Vulnerability Assessment;</p> <p>OR</p> <p>The responsible entity does not have a completed benchmark GMD Vulnerability Assessment.</p>

VSL Justifications – TPL-007-2, R4	
NERC VSL Guidelines	Consistent with NERC's VSL Guidelines. The requirement may be described by elements or quantities to evaluate degrees of compliance. Four VSLs are specified for a graduated scale.
FERC VSL G1 Violation Severity Level Assignments Should Not Have the Unintended Consequence of Lowering the Current Level of Compliance	The VSL is not changed in TPL-007-2.
FERC VSL G2 Violation Severity Level Assignments Should Ensure Uniformity and Consistency in the Determination of Penalties Guideline 2a: The Single Violation Severity Level Assignment Category for "Binary" Requirements Is Not Consistent Guideline 2b: Violation Severity Level Assignments that Contain Ambiguous Language	The proposed VSL is written to ensure uniformity and consistency in the determination of penalties.  Guideline 2a: The proposed VSL is not binary.  Guideline 2b: The proposed VSL does not use ambiguous terms, supporting uniformity and consistency in the determination of similar penalties for similar violations.

VSL Justifications – TPL-007-2, R4	
FERC VSL G3 Violation Severity Level Assignment Should Be Consistent with the Corresponding Requirement	The proposed VSL is worded consistently with the corresponding requirement.
FERC VSL G4 Violation Severity Level Assignment Should Be Based on A Single Violation, Not on A Cumulative Number of Violations	The proposed VSL is not based on a cumulative number of violations.

VRF Justifications – TPL-007-2, R5	
<b>Proposed VRF</b>	<b>Medium</b>
FERC VRF G1 Discussion	Guideline 1- Consistency w/ Blackout Report: N/A
FERC VRF G2 Discussion	Guideline 2- Consistency within a Reliability Standard: The requirement has no sub-requirements so a single VRF was assigned.

<b>VRF Justifications – TPL-007-2, R5</b>	
<b>Proposed VRF</b>	<b>Medium</b>
FERC VRF G3 Discussion	Guideline 3- Consistency among Reliability Standards. A VRF of Medium is consistent with Reliability Standard MOD-032-1 Requirement R2 which requires applicable entities to provide modeling data to Transmission Planners and Planning Coordinators. A VRF of Medium is also consistent with Reliability Standard IRO-010-2 Requirement R3 which requires entities to provide data necessary for the Reliability Coordinator to perform its Operational Planning Analysis and Real-time Assessments. Proposed TPL-007-2 Requirement R5 requires responsible entities to provide specific geomagnetically-induced currents (GIC) flow information to Transmission Owners and Generator Owners for performing transformer thermal impact assessments.
FERC VRF G4 Discussion	Guideline 4- Consistency with NERC Definitions of VRFs. The VRF of Medium is consistent with the NERC VRF Definition. Failure to provide GIC flow information for the benchmark GMD event could directly and adversely affect the electrical state or capability of the Bulk Electric System, or the ability to effectively monitor, control, or restore the Bulk Electric System during a GMD event. However, it is unlikely that such a failure by itself would lead to Bulk Electric System instability, separation, or cascading.
FERC VRF G5 Discussion	Guideline 5- Treatment of Requirements that Co-mingle More than One Obligation. This requirement does not co-mingle a higher-risk reliability objective with a lesser- risk reliability objective.

<b>Proposed VSLs – TPL-007-2, R5</b>			
<b>Lower</b>	<b>Moderate</b>	<b>High</b>	<b>Severe</b>
The responsible entity provided the effective GIC time series, GIC(t), in response to written request, but did so more than 90 calendar days and less than or equal to 100 calendar days after receipt of a written request.	The responsible entity provided the effective GIC time series, GIC(t), in response to written request, but did so more than 100 calendar days and less than or equal to 110 calendar days after receipt of a written request.	The responsible entity provided the effective GIC time series, GIC(t), in response to written request, but did so more than 110 calendar days after receipt of a written request.	The responsible entity did not provide the maximum effective GIC value to the Transmission Owner and Generator Owner that owns each applicable BES power transformer in the planning area;  OR  The responsible entity did not provide the effective GIC time series, GIC(t), upon written request.

<b>VSL Justifications – TPL-007-2, R5</b>	
NERC VSL Guidelines	Consistent with NERC's VSL Guidelines. The requirement may be described by elements or quantities to evaluate degrees of compliance. Four VSLs are specified for a graduated scale.
FERC VSL G1 Violation Severity Level Assignments Should Not Have the Unintended Consequence of Lowering the Current Level of Compliance	The VSL is not changed in TPL-007-2.

VSL Justifications – TPL-007-2, R5	
<p>FERC VSL G2 Violation Severity Level Assignments Should Ensure Uniformity and Consistency in the Determination of Penalties Guideline 2a: The Single Violation Severity Level Assignment Category for "Binary" Requirements Is Not Consistent Guideline 2b: Violation Severity Level Assignments that Contain Ambiguous Language</p>	<p>The proposed VSL is written to ensure uniformity and consistency in the determination of penalties.</p> <p>Guideline 2a: The proposed VSL is not binary.</p> <p>Guideline 2b: The proposed VSL does not use ambiguous terms, supporting uniformity and consistency in the determination of similar penalties for similar violations.</p>
<p>FERC VSL G3 Violation Severity Level Assignment Should Be Consistent with the Corresponding Requirement</p>	<p>The proposed VSL is worded consistently with the corresponding requirement.</p>
<p>FERC VSL G4 Violation Severity Level Assignment Should Be Based on A Single Violation, Not on A Cumulative Number of Violations</p>	<p>The proposed VSL is not based on a cumulative number of violations.</p>

<b>VRF Justifications – TPL-007-2, R6</b>	
<b>Proposed VRF</b>	<b>Medium</b>
FERC VRF G1 Discussion	Guideline 1- Consistency w/ Blackout Report: N/A
FERC VRF G2 Discussion	Guideline 2- Consistency within a Reliability Standard: The requirement has no sub-requirements so a single VRF was assigned.
FERC VRF G3 Discussion	Guideline 3- Consistency among Reliability Standards. A VRF of Medium is consistent with Reliability Standard FAC-008-3 Requirement R6 which requires Transmission Owners and Generator Owners to have Facility Ratings for all solely and jointly owned Facilities that are consistent with the associated Facility Ratings methodology or documentation. Proposed TPL-007-2 Requirement R6 requires responsible entities to conduct a benchmark thermal impact assessment for solely and jointly owned applicable transformers and provide results including suggested actions to mitigate identified impacts to planning entities.
FERC VRF G4 Discussion	Guideline 4- Consistency with NERC Definitions of VRFs. The VRF of Medium is consistent with the NERC VRF Definition. Failure to conduct a benchmark transformer thermal impact assessment could directly and adversely affect the electrical state or capability of the Bulk Electric System, or the ability to effectively monitor, control, or restore the Bulk Electric System during a GMD event. However, it is unlikely that such a failure by itself would lead to Bulk Electric System instability, separation, or cascading.
FERC VRF G5 Discussion	Guideline 5- Treatment of Requirements that Co-mingle More than One Obligation. This requirement does not co-mingle a higher-risk reliability objective with a lesser- risk reliability objective.

<b>Proposed VSLs – TPL-007-2, R6</b>			
<b>Lower</b>	<b>Moderate</b>	<b>High</b>	<b>Severe</b>
<p>The responsible entity failed to conduct a benchmark thermal impact assessment for 5% or less or one of its solely owned and jointly owned applicable BES power transformers (whichever is greater) where the maximum effective GIC value provided in Requirement R5, Part 5.1, is 75 A or greater per phase;</p> <p>OR</p> <p>The responsible entity conducted a benchmark thermal impact assessment for its solely owned and jointly owned applicable BES power transformers where the maximum effective GIC value provided in Requirement R5, Part 5.1, is 75 A or greater per phase but did so more than 24 calendar months and less than or equal to 26 calendar months</p>	<p>The responsible entity failed to conduct a benchmark thermal impact assessment for more than 5% up to (and including) 10% or two of its solely owned and jointly owned applicable BES power transformers (whichever is greater) where the maximum effective GIC value provided in Requirement R5, Part 5.1, is 75 A or greater per phase;</p> <p>OR</p> <p>The responsible entity conducted a benchmark thermal impact assessment for its solely owned and jointly owned applicable BES power transformers where the maximum effective GIC value provided in Requirement R5, Part 5.1, is 75 A or greater per phase but did so more than 26 calendar months and less than</p>	<p>The responsible entity failed to conduct a benchmark thermal impact assessment for more than 10% up to (and including) 15% or three of its solely owned and jointly owned applicable BES power transformers (whichever is greater) where the maximum effective GIC value provided in Requirement R5, Part 5.1, is 75 A or greater per phase;</p> <p>OR</p> <p>The responsible entity conducted a benchmark thermal impact assessment for its solely owned and jointly owned applicable BES power transformers where the maximum effective GIC value provided in Requirement R5, Part 5.1, is 75 A or greater per phase but did so more than 28 calendar months and less than</p>	<p>The responsible entity failed to conduct a benchmark thermal impact assessment for more than 15% or more than three of its solely owned and jointly owned applicable BES power transformers (whichever is greater) where the maximum effective GIC value provided in Requirement R5, Part 5.1, is 75 A or greater per phase;</p> <p>OR</p> <p>The responsible entity conducted a benchmark thermal impact assessment for its solely owned and jointly owned applicable BES power transformers where the maximum effective GIC value provided in Requirement R5, Part 5.1, is 75 A or greater per phase but did so more than 30 calendar months of receiving</p>



<b>Proposed VSLs – TPL-007-2, R6</b>			
<b>Lower</b>	<b>Moderate</b>	<b>High</b>	<b>Severe</b>
of receiving GIC flow information specified in Requirement R5, Part 5.1.	or equal to 28 calendar months of receiving GIC flow information specified in Requirement R5, Part 5.1; OR The responsible entity failed to include one of the required elements as listed in Requirement R6, Parts 6.1 through 6.3.	or equal to 30 calendar months of receiving GIC flow information specified in Requirement R5, Part 5.1; OR The responsible entity failed to include two of the required elements as listed in Requirement R6, Parts 6.1 through 6.3.	GIC flow information specified in Requirement R5, Part 5.1; OR The responsible entity failed to include three of the required elements as listed in Requirement R6, Parts 6.1 through 6.3.

<b>VSL Justifications – TPL-007-2, R6</b>	
NERC VSL Guidelines	Consistent with NERC's VSL Guidelines. The requirement may be described by elements or quantities to evaluate degrees of compliance. Four VSLs are specified for a graduated scale.
FERC VSL G1 Violation Severity Level Assignments Should Not Have the Unintended Consequence of Lowering the Current Level of Compliance	The VSL is not changed in TPL-007-2.

VSL Justifications – TPL-007-2, R6	
<p>FERC VSL G2 Violation Severity Level Assignments Should Ensure Uniformity and Consistency in the Determination of Penalties Guideline 2a: The Single Violation Severity Level Assignment Category for "Binary" Requirements Is Not Consistent Guideline 2b: Violation Severity Level Assignments that Contain Ambiguous Language</p>	<p>The proposed VSL is written to ensure uniformity and consistency in the determination of penalties.</p> <p>Guideline 2a: The proposed VSL is not binary.</p> <p>Guideline 2b: The proposed VSL does not use ambiguous terms, supporting uniformity and consistency in the determination of similar penalties for similar violations.</p>
<p>FERC VSL G3 Violation Severity Level Assignment Should Be Consistent with the Corresponding Requirement</p>	<p>The proposed VSL is worded consistently with the corresponding requirement.</p>
<p>FERC VSL G4 Violation Severity Level Assignment Should Be Based on A Single Violation, Not on A Cumulative Number of Violations</p>	<p>The proposed VSL is not based on a cumulative number of violations.</p>

VRF Justifications – TPL-007-2, R7	
Proposed VRF	High
FERC VRF G1 Discussion	Guideline 1- Consistency w/ Blackout Report: N/A
FERC VRF G2 Discussion	Guideline 2- Consistency within a Reliability Standard: The requirement has no sub-requirements so a single VRF was assigned.
FERC VRF G3 Discussion	Guideline 3- Consistency among Reliability Standards. A VRF of High is consistent with Reliability Standard TPL-001-4 Requirement R2 which requires Transmission Planners and Planning Coordinators to include a Corrective Action Plan that addresses identified performance issues in the annual Planning Assessment. Proposed TPL-007-2 Requirement R7 requires responsible entities to develop a Corrective Action Plan when results of the benchmark GMD Vulnerability Assessment indicate that the System does not meet performance requirements. While Reliability Standard TPL-001-4 has a single requirement for performing the Planning Assessment and developing the Corrective Action Plan, proposed TPL-007-2 has split the requirements for performing a benchmark GMD Vulnerability Assessment and developing the Corrective Action Plan into two separate requirements because the transformer thermal impact assessments performed by Transmission Owners and Generator Owners must be considered. The sequencing with separate requirements follows a logical flow of the GMD Vulnerability Assessment process.
FERC VRF G4 Discussion	Guideline 4- Consistency with NERC Definitions of VRFs. The VRF of High is consistent with the NERC VRF Definition. Failure to develop a Corrective Action Plan that addresses issues identified in a GMD Vulnerability Assessment could, under GMD conditions that are as severe as the benchmark GMD event, place the Bulk Electric System at an unacceptable risk of instability, separation, or cascading failures.
FERC VRF G5 Discussion	Guideline 5- Treatment of Requirements that Co-mingle More than One Obligation. This requirement does not co-mingle a higher-risk reliability objective with a lesser- risk reliability objective.

<b>Proposed VSLs – TPL-007-2, R7</b>			
<b>Lower</b>	<b>Moderate</b>	<b>High</b>	<b>Severe</b>
The responsible entity's Corrective Action Plan failed to comply with one of the elements in Requirement R7, Parts 7.1 through 7.5.	The responsible entity's Corrective Action Plan failed to comply with two of the elements in Requirement R7, Parts 7.1 through 7.5.	The responsible entity's Corrective Action Plan failed to comply with three of the elements in Requirement R7, Parts 7.1 through 7.5.	The responsible entity's Corrective Action Plan failed to comply with four or more of the elements in Requirement R7, Parts 7.1 through 7.5; OR The responsible entity did not have a Corrective Action Plan as required by Requirement R7.

<b>VSL Justifications – TPL-007-2, R7</b>	
NERC VSL Guidelines	Consistent with NERC's VSL Guidelines. The requirement may be described by elements or quantities to evaluate degrees of compliance. Four VSLs are specified for a graduated scale.
FERC VSL G1 Violation Severity Level Assignments Should Not Have the Unintended Consequence of Lowering the Current Level of Compliance	The proposed requirement is a significant revision to TPL-007-2 to address the directive for Corrective Action Plan deadlines contained in FERC Order No. 830. There is no prior compliance obligation related to the directive. However, the requirement uses the same construct for a graduated scale as TPL-007-1 Requirement R7 and is similar to Reliability Standard TPL-001-4, Requirement R2.

VSL Justifications – TPL-007-2, R7	
<p>FERC VSL G2 Violation Severity Level Assignments Should Ensure Uniformity and Consistency in the Determination of Penalties Guideline 2a: The Single Violation Severity Level Assignment Category for "Binary" Requirements Is Not Consistent Guideline 2b: Violation Severity Level Assignments that Contain Ambiguous Language</p>	<p>The proposed VSL is written to ensure uniformity and consistency in the determination of penalties.</p> <p>Guideline 2a: The proposed VSL is not binary.</p> <p>Guideline 2b: The proposed VSL does not use ambiguous terms, supporting uniformity and consistency in the determination of similar penalties for similar violations.</p>
<p>FERC VSL G3 Violation Severity Level Assignment Should Be Consistent with the Corresponding Requirement</p>	<p>The proposed VSL is worded consistently with the corresponding requirement.</p>
<p>FERC VSL G4 Violation Severity Level Assignment Should Be Based on A Single Violation, Not on A Cumulative Number of Violations</p>	<p>The proposed VSL is not based on a cumulative number of violations.</p>

<b>VRF Justifications – TPL-007-2, R8</b>	
<b>Proposed VRF</b>	<b>High</b>
FERC VRF G1 Discussion	Guideline 1- Consistency w/ Blackout Report: N/A
FERC VRF G2 Discussion	Guideline 2- Consistency within a Reliability Standard: The requirement has no sub-requirements so a single VRF was assigned.
FERC VRF G3 Discussion	Guideline 3- Consistency among Reliability Standards. A VRF of High is consistent with Reliability Standard TPL-001-4 Requirement R2 which requires Transmission Planners and Planning Coordinators to prepare an annual Planning Assessment to ensure its portion of the Bulk Electric System meets performance criteria. The proposed requirement is also consistent with approved TPL-007-1 Requirement R4 (unchanged in proposed TPL-007-2 Requirement R4). Proposed TPL-007-2 Requirement R8 requires responsible entities to complete a supplemental GMD Vulnerability Assessment to assess system performance during a supplemental GMD event.
FERC VRF G4 Discussion	Guideline 4- Consistency with NERC Definitions of VRFs. The VRF of High is consistent with the NERC VRF Definition. Failure to complete a supplemental GMD Vulnerability Assessment could, under GMD conditions that are as severe as the supplemental GMD event, place the Bulk Electric System at an unacceptable risk of instability, separation, or cascading failures by precluding responsible entities from considering actions to mitigate risk of Cascading.
FERC VRF G5 Discussion	Guideline 5- Treatment of Requirements that Co-mingle More than One Obligation. This requirement does not co-mingle a higher-risk reliability objective with a lesser- risk reliability objective.

<b>Proposed VSLs – TPL-007-2, R8</b>			
<b>Lower</b>	<b>Moderate</b>	<b>High</b>	<b>Severe</b>
<p>The responsible entity's completed supplemental GMD Vulnerability Assessment failed to satisfy one of elements listed in Requirement R8, Parts 8.1 through 8.4;</p> <p>OR</p> <p>The responsible entity completed a supplemental GMD Vulnerability Assessment, but it was more than 60 calendar months and less than or equal to 64 calendar months since the last supplemental GMD Vulnerability Assessment.</p>	<p>The responsible entity's completed supplemental GMD Vulnerability Assessment failed to satisfy two of elements listed in Requirement R8, Parts 8.1 through 8.4;</p> <p>OR</p> <p>The responsible entity completed a supplemental GMD Vulnerability Assessment, but it was more than 64 calendar months and less than or equal to 68 calendar months since the last supplemental GMD Vulnerability Assessment.</p>	<p>The responsible entity's completed supplemental GMD Vulnerability Assessment failed to satisfy three of the elements listed in Requirement R8, Parts 8.1 through 8.4;</p> <p>OR</p> <p>The responsible entity completed a supplemental GMD Vulnerability Assessment, but it was more than 68 calendar months and less than or equal to 72 calendar months since the last supplemental GMD Vulnerability Assessment.</p>	<p>The responsible entity's completed supplemental GMD Vulnerability Assessment failed to satisfy four of the elements listed in Requirement R8, Parts 8.1 through 8.4;</p> <p>OR</p> <p>The responsible entity completed a supplemental GMD Vulnerability Assessment, but it was more than 72 calendar months since the last supplemental GMD Vulnerability Assessment;</p> <p>OR</p> <p>The responsible entity does not have a completed supplemental GMD Vulnerability Assessment.</p>

VSL Justifications – TPL-007-2, R8	
NERC VSL Guidelines	Consistent with NERC's VSL Guidelines. The requirement may be described by elements or quantities to evaluate degrees of compliance. Four VSLs are specified for a graduated scale.
FERC VSL G1 Violation Severity Level Assignments Should Not Have the Unintended Consequence of Lowering the Current Level of Compliance	There is no prior compliance obligation related to supplemental GMD Vulnerability Assessment. However, the requirement is similar to approved TPL-007-1, Requirement R4 (unchanged in proposed TPL-007-2 Requirement R4). That requirement also has a graduated scale for VSLs.
FERC VSL G2 Violation Severity Level Assignments Should Ensure Uniformity and Consistency in the Determination of Penalties Guideline 2a: The Single Violation Severity Level Assignment Category for "Binary" Requirements Is Not Consistent Guideline 2b: Violation Severity Level Assignments that Contain Ambiguous Language	<p>The proposed VSL is written to ensure uniformity and consistency in the determination of penalties.</p> <p>Guideline 2a: The proposed VSL is not binary.</p> <p>Guideline 2b: The proposed VSL does not use ambiguous terms, supporting uniformity and consistency in the determination of similar penalties for similar violations.</p>



<b>VSL Justifications – TPL-007-2, R8</b>	
<p>FERC VSL G3 Violation Severity Level Assignment Should Be Consistent with the Corresponding Requirement</p>	<p>The proposed VSL is worded consistently with the corresponding requirement.</p>
<p>FERC VSL G4 Violation Severity Level Assignment Should Be Based on A Single Violation, Not on A Cumulative Number of Violations</p>	<p>The proposed VSL is not based on a cumulative number of violations.</p>

<b>VRF Justifications – TPL-007-2, R9</b>	
<b>Proposed VRF</b>	<b>Medium</b>
FERC VRF G1 Discussion	Guideline 1- Consistency w/ Blackout Report: N/A
FERC VRF G2 Discussion	Guideline 2- Consistency within a Reliability Standard: The requirement has no sub-requirements so a single VRF was assigned.
FERC VRF G3 Discussion	Guideline 3- Consistency among Reliability Standards. A VRF of Medium is consistent with approved TPL-007-1 Requirement R5 (unchanged in proposed TPL-007-2 Requirement R5) which requires responsible entities to provide specific geomagnetically-induced currents (GIC) flow information to Transmission Owners and Generator Owners for performing transformer thermal impact assessments.

<b>VRF Justifications – TPL-007-2, R9</b>	
<b>Proposed VRF</b>	<b>Medium</b>
FERC VRF G4 Discussion	Guideline 4- Consistency with NERC Definitions of VRFs. The VRF of Medium is consistent with the NERC VRF Definition. Failure to provide GIC flow information for the supplemental GMD event could directly and adversely affect the electrical state or capability of the Bulk Electric System, or the ability to effectively monitor, control, or restore the Bulk Electric System during a GMD event. However, it is unlikely that such a failure by itself would lead to Bulk Electric System instability, separation, or cascading.
FERC VRF G5 Discussion	Guideline 5- Treatment of Requirements that Co-mingle More than One Obligation. This requirement does not co-mingle a higher-risk reliability objective with a lesser- risk reliability objective.

<b>Proposed VSLs – TPL-007-2, R9</b>			
<b>Lower</b>	<b>Moderate</b>	<b>High</b>	<b>Severe</b>
The responsible entity provided the effective GIC time series, GIC(t), in response to written request, but did so more than 90 calendar days and less than or equal to 100 calendar days after receipt of a written request.	The responsible entity provided the effective GIC time series, GIC(t), in response to written request, but did so more than 100 calendar days and less than or equal to 110 calendar days after receipt of a written request.	The responsible entity provided the effective GIC time series, GIC(t), in response to written request, but did so more than 110 calendar days after receipt of a written request.	The responsible entity did not provide the maximum effective GIC value to the Transmission Owner and Generator Owner that owns each applicable BES power transformer in the planning area;  OR  The responsible entity did not provide the effective GIC time series, GIC(t), upon written request.

<b>VSL Justifications – TPL-007-2, R9</b>	
NERC VSL Guidelines	Consistent with NERC's VSL Guidelines. The requirement may be described by elements or quantities to evaluate degrees of compliance. Four VSLs are specified for a graduated scale.

VSL Justifications – TPL-007-2, R9	
<p>FERC VSL G1 Violation Severity Level Assignments Should Not Have the Unintended Consequence of Lowering the Current Level of Compliance</p>	<p>There is no prior compliance obligation related to supplemental GMD Vulnerability Assessment. However, the requirement is similar to approved TPL-007-1, Requirement R5 (unchanged in proposed TPL-007-2 Requirement R5). That requirement also has a graduated scale for VSLs.</p>
<p>FERC VSL G2 Violation Severity Level Assignments Should Ensure Uniformity and Consistency in the Determination of Penalties Guideline 2a: The Single Violation Severity Level Assignment Category for "Binary" Requirements Is Not Consistent Guideline 2b: Violation Severity Level Assignments that Contain Ambiguous Language</p>	<p>The proposed VSL is written to ensure uniformity and consistency in the determination of penalties.</p> <p>Guideline 2a: The proposed VSL is not binary.</p> <p>Guideline 2b: The proposed VSL does not use ambiguous terms, supporting uniformity and consistency in the determination of similar penalties for similar violations.</p>
<p>FERC VSL G3 Violation Severity Level Assignment Should Be Consistent with the Corresponding Requirement</p>	<p>The proposed VSL is worded consistently with the corresponding requirement.</p>

<b>VSL Justifications – TPL-007-2, R9</b>	
<p>FERC VSL G4 Violation Severity Level Assignment Should Be Based on A Single Violation, Not on A Cumulative Number of Violations</p>	<p>The proposed VSL is not based on a cumulative number of violations.</p>

<b>VRF Justifications – TPL-007-2, R10</b>	
<b>Proposed VRF</b>	<b>Medium</b>
FERC VRF G1 Discussion	Guideline 1- Consistency w/ Blackout Report: N/A
FERC VRF G2 Discussion	Guideline 2- Consistency within a Reliability Standard: The requirement has no sub-requirements so a single VRF was assigned.
FERC VRF G3 Discussion	Guideline 3- Consistency among Reliability Standards. A VRF of Medium is consistent with approved TPL-007-1 Requirement R6 (unchanged in proposed TPL-007-2 Requirement R6), which requires responsible entities to conduct a benchmark thermal impact assessment for solely and jointly owned applicable transformers and provide results including suggested actions to mitigate identified impacts to planning entities.
FERC VRF G4 Discussion	Guideline 4- Consistency with NERC Definitions of VRFs. The VRF of Medium is consistent with the NERC VRF Definition. Failure to conduct a supplemental transformer thermal impact assessment could directly and adversely affect the electrical state or capability of the Bulk Electric System, or the ability to effectively monitor, control, or restore the Bulk Electric System during a GMD event. However, it is unlikely that such a failure by itself would lead to Bulk Electric System instability, separation, or cascading.

<b>VRF Justifications – TPL-007-2, R10</b>	
<b>Proposed VRF</b>	<b>Medium</b>
FERC VRF G5 Discussion	Guideline 5- Treatment of Requirements that Co-mingle More than One Obligation. This requirement does not co-mingle a higher-risk reliability objective with a lesser- risk reliability objective.

<b>Proposed VSLs – TPL-007-2, R10</b>			
<b>Lower</b>	<b>Moderate</b>	<b>High</b>	<b>Severe</b>
<p>The responsible entity failed to conduct a supplemental thermal impact assessment for 5% or less or one of its solely owned and jointly owned applicable BES power transformers (whichever is greater) where the maximum effective GIC value provided in Requirement R9, Part 9.1, is 85 A or greater per phase;</p> <p>OR</p> <p>The responsible entity conducted a supplemental thermal impact assessment for its solely owned and jointly owned applicable BES power</p>	<p>The responsible entity failed to conduct a supplemental thermal impact assessment for more than 5% up to (and including) 10% or two of its solely owned and jointly owned applicable BES power transformers (whichever is greater) where the maximum effective GIC value provided in Requirement R9, Part 9.1, is 85 A or greater per phase;</p> <p>OR</p> <p>The responsible entity conducted a supplemental thermal impact assessment for its solely owned and jointly</p>	<p>The responsible entity failed to conduct a supplemental thermal impact assessment for more than 10% up to (and including) 15% or three of its solely owned and jointly owned applicable BES power transformers (whichever is greater) where the maximum effective GIC value provided in Requirement R9, Part 9.1, is 85 A or greater per phase;</p> <p>OR</p> <p>The responsible entity conducted a supplemental thermal impact assessment for its solely owned and jointly</p>	<p>The responsible entity failed to conduct a supplemental thermal impact assessment for more than 15% or more than three of its solely owned and jointly owned applicable BES power transformers (whichever is greater) where the maximum effective GIC value provided in Requirement R9, Part 9.1, is 85 A or greater per phase;</p> <p>OR</p> <p>The responsible entity conducted a supplemental thermal impact assessment for its solely owned and jointly owned applicable BES power</p>

<b>Proposed VSLs – TPL-007-2, R10</b>			
<b>Lower</b>	<b>Moderate</b>	<b>High</b>	<b>Severe</b>
transformers where the maximum effective GIC value provided in Requirement R9, Part 9.1, is 85 A or greater per phase but did so more than 24 calendar months and less than or equal to 26 calendar months of receiving GIC flow information specified in Requirement R9, Part 9.1.	<p>owned applicable BES power transformers where the maximum effective GIC value provided in Requirement R9, Part 9.1, is 85 A or greater per phase but did so more than 26 calendar months and less than or equal to 28 calendar months of receiving GIC flow information specified in Requirement R9, Part 9.1</p> <p>OR</p> <p>The responsible entity failed to include one of the required elements as listed in Requirement R10, Parts 10.1 through 10.3.</p>	<p>owned applicable BES power transformers where the maximum effective GIC value provided in Requirement R9, Part 9.1, is 85 A or greater per phase but did so more than 28 calendar months and less than or equal to 30 calendar months of receiving GIC flow information specified in Requirement R9, Part 9.1;</p> <p>OR</p> <p>The responsible entity failed to include two of the required elements as listed in Requirement R10, Parts 10.1 through 10.3.</p>	<p>transformers where the maximum effective GIC value provided in Requirement R9, Part 9.1, is 85 A or greater per phase but did so more than 30 calendar months of receiving GIC flow information specified in Requirement R9, Part 9.1;</p> <p>OR</p> <p>The responsible entity failed to include three of the required elements as listed in Requirement R10, Parts 10.1 through 10.3.</p>

<b>VSL Justifications – TPL-007-2, R10</b>	
NERC VSL Guidelines	Consistent with NERC's VSL Guidelines. The requirement may be described by elements or quantities to evaluate degrees of compliance. Four VSLs are specified for a graduated scale.

VSL Justifications – TPL-007-2, R10	
<p>FERC VSL G1 Violation Severity Level Assignments Should Not Have the Unintended Consequence of Lowering the Current Level of Compliance</p>	<p>There is no prior compliance obligation related to supplemental thermal impact assessment. However, the requirement is similar to approved TPL-007-1, Requirement R6 (unchanged in proposed TPL-007-2 Requirement R6). That requirement also has a graduated scale for VSLs.</p>
<p>FERC VSL G2 Violation Severity Level Assignments Should Ensure Uniformity and Consistency in the Determination of Penalties Guideline 2a: The Single Violation Severity Level Assignment Category for "Binary" Requirements Is Not Consistent Guideline 2b: Violation Severity Level Assignments that Contain Ambiguous Language</p>	<p>The proposed VSL is written to ensure uniformity and consistency in the determination of penalties.</p> <p>Guideline 2a: The proposed VSL is not binary.</p> <p>Guideline 2b: The proposed VSL does not use ambiguous terms, supporting uniformity and consistency in the determination of similar penalties for similar violations.</p>
<p>FERC VSL G3 Violation Severity Level Assignment Should Be Consistent with the Corresponding Requirement</p>	<p>The proposed VSL is worded consistently with the corresponding requirement.</p>



<b>VSL Justifications – TPL-007-2, R10</b>	
<p>FERC VSL G4 Violation Severity Level Assignment Should Be Based on A Single Violation, Not on A Cumulative Number of Violations</p>	<p>The proposed VSL is not based on a cumulative number of violations.</p>

<b>VRF Justifications – TPL-007-2, R11</b>	
<b>Proposed VRF</b>	<b>Lower</b>
FERC VRF G1 Discussion	Guideline 1- Consistency w/ Blackout Report: N/A
FERC VRF G2 Discussion	Guideline 2- Consistency within a Reliability Standard: The requirement has no sub-requirements so a single VRF was assigned.
FERC VRF G3 Discussion	Guideline 3- Consistency among Reliability Standards. A VRF of Lower is consistent with approved Reliability Standards requiring entities to implement processes to obtain data. These include Reliability Standard MOD-032-1 Requirement R1 and Reliability Standard IRO-010-2 Requirement R1.
FERC VRF G4 Discussion	Guideline 4- Consistency with NERC Definitions of VRFs. The VRF of Lower is consistent with the NERC VRF Definition. Failure to obtain GIC monitor data from at least one GIC monitor located in the system would not be expected to adversely affect the electrical state or capability of the Bulk Electric System, or the ability to effectively monitor, control, or restore the Bulk Electric System.
FERC VRF G5 Discussion	Guideline 5- Treatment of Requirements that Co-mingle More than One Obligation. This requirement does not co-mingle a higher-risk reliability objective with a lesser- risk reliability objective.

Proposed VSLs – TPL-007-2, R11			
Lower	Moderate	High	Severe
N/A	N/A	N/A	The responsible entity did not implement a process to obtain GIC monitor data from at least one GIC monitor located in the Planning Coordinator’s planning area or other part of the system included in the Planning Coordinator’s GIC System Model.

VSL Justifications – TPL-007-2, R11	
NERC VSL Guidelines	Consistent with NERC's VSL Guidelines. The requirement does not have elements or quantities to evaluate degrees of compliance. A VSL of Severe is assigned for non-compliance.
FERC VSL G1 Violation Severity Level Assignments Should Not Have the Unintended Consequence of Lowering the Current Level of Compliance	There is no prior compliance obligation for this requirement.

VSL Justifications – TPL-007-2, R11

<p>FERC VSL G2 Violation Severity Level Assignments Should Ensure Uniformity and Consistency in the Determination of Penalties Guideline 2a: The Single Violation Severity Level Assignment Category for "Binary" Requirements Is Not Consistent Guideline 2b: Violation Severity Level Assignments that Contain Ambiguous Language</p>	<p>The proposed VSL is written to ensure uniformity and consistency in the determination of penalties.</p> <p>Guideline 2a: The proposed VSL is binary and assigned a Severe VSL.</p> <p>Guideline 2b: The proposed VSL does not use ambiguous terms, supporting uniformity and consistency in the determination of similar penalties for similar violations.</p>
<p>FERC VSL G3 Violation Severity Level Assignment Should Be Consistent with the Corresponding Requirement</p>	<p>The proposed VSL is worded consistently with the corresponding requirement.</p>
<p>FERC VSL G4 Violation Severity Level Assignment Should Be Based on A Single Violation, Not on A Cumulative Number of Violations</p>	<p>The proposed VSL is not based on a cumulative number of violations.</p>

<b>VRF Justifications – TPL-007-2, R12</b>	
<b>Proposed VRF</b>	<b>Lower</b>
FERC VRF G1 Discussion	Guideline 1- Consistency w/ Blackout Report: N/A
FERC VRF G2 Discussion	Guideline 2- Consistency within a Reliability Standard: The requirement has no sub-requirements so a single VRF was assigned.
FERC VRF G3 Discussion	Guideline 3- Consistency among Reliability Standards. A VRF of Lower is consistent with approved Reliability Standards requiring entities to implement processes to obtain data. These include Reliability Standard MOD-032-1 Requirement R1 and Reliability Standard IRO-010-2 Requirement R1.
FERC VRF G4 Discussion	Guideline 4- Consistency with NERC Definitions of VRFs. The VRF of Lower is consistent with the NERC VRF Definition. Failure to obtain geomagnetic field data for the planning area would not be expected to adversely affect the electrical state or capability of the Bulk Electric System, or the ability to effectively monitor, control, or restore the Bulk Electric System.
FERC VRF G5 Discussion	Guideline 5- Treatment of Requirements that Co-mingle More than One Obligation. This requirement does not co-mingle a higher-risk reliability objective with a lesser- risk reliability objective.

Proposed VSLs – TPL-007-2, R12			
Lower	Moderate	High	Severe
N/A	N/A	N/A	The responsible entity did not implement a process to obtain geomagnetic field data for its Planning Coordinator’s planning area.

VSL Justifications – TPL-007-2, R12	
NERC VSL Guidelines	Consistent with NERC's VSL Guidelines. The requirement does not have elements or quantities to evaluate degrees of compliance. A VSL of Severe is assigned for non-compliance.
FERC VSL G1 Violation Severity Level Assignments Should Not Have the Unintended Consequence of Lowering the Current Level of Compliance	There is no prior compliance obligation for this requirement.
FERC VSL G2 Violation Severity Level Assignments Should Ensure Uniformity and Consistency in the Determination of Penalties Guideline 2a: The Single Violation Severity Level	The proposed VSL is written to ensure uniformity and consistency in the determination of penalties.  Guideline 2a: The proposed VSL is binary and assigned a Severe VSL.

VSL Justifications – TPL-007-2, R12

<p>Assignment Category for "Binary" Requirements Is Not Consistent</p> <p>Guideline 2b: Violation Severity Level Assignments that Contain Ambiguous Language</p>	<p>Guideline 2b: The proposed VSL does not use ambiguous terms, supporting uniformity and consistency in the determination of similar penalties for similar violations.</p>
<p>FERC VSL G3</p> <p>Violation Severity Level Assignment Should Be Consistent with the Corresponding Requirement</p>	<p>The proposed VSL is worded consistently with the corresponding requirement.</p>
<p>FERC VSL G4</p> <p>Violation Severity Level Assignment Should Be Based on A Single Violation, Not on A Cumulative Number of Violations</p>	<p>The proposed VSL is not based on a cumulative number of violations.</p>

## **Exhibit D**

### **Summary of Development History and Complete Record of Development**

## **Summary of Development History**



## **Summary of Development History**

The development record for proposed Reliability Standard TPL-007-2 is summarized below.

### **I. Overview of the Standard Drafting Team**

When evaluating a proposed Reliability Standard, the Commission is expected to give “due weight” to the technical expertise of the ERO.<sup>1</sup> The technical expertise of the ERO is derived from the standard drafting team selected to lead each project in accordance with Section 4.3 of the NERC Standards Process Manual.<sup>2</sup> For this project, the standard drafting team consisted of industry experts, all with a diverse set of experiences. A roster of the Standard Drafting team (“SDT”) members is included in **Exhibit F**.

### **II. Standard Development History**

#### **A. Standard Authorization Request Development**

Project 2013-03 – Geomagnetic Disturbance Mitigation was initiated to address Commission directives in Order No. 830.<sup>3</sup> In Order No. 830, the Commission directed NERC to:

- (1) Modify the benchmark GMD event definition used for GMD Vulnerability Assessments;
- (2) Make related modifications to requirements pertaining to transformer thermal impact assessments;
- (3) Require collection of GMD-related data, which NERC is to make publicly available; and
- (4) Require deadlines for Corrective Action Plans and GMD mitigating actions.<sup>4</sup>

---

<sup>1</sup> Section 215(d)(2) of the Federal Power Act; 16 U.S.C. §824(d)(2) (2012).

<sup>2</sup> The NERC *Standard Processes Manual* is available at [http://www.nerc.com/comm/SC/Documents/Appendix\\_3A\\_StandardsProcessesManual.pdf](http://www.nerc.com/comm/SC/Documents/Appendix_3A_StandardsProcessesManual.pdf).

<sup>3</sup> Order No. 830, *Reliability Standard for Transmission System Planned Performance for Geomagnetic Disturbance Events*, 156 FERC ¶ 61,215, 81 Fed. Reg. 67,210 (2016).

<sup>4</sup> *Id.*

The Commission directed NERC to file the modifications within 18 months of the effective date of Order No. 830. A Standard Authorization Request (“SAR”) was posted for a 30-day formal comment period from December 16, 2016 through January 20, 2017. The Standards Committee accepted the SAR on March 16, 2017.

### **B. First Posting – Comment Period, Initial Ballot and Non-binding Poll**

Proposed Reliability Standard TPL-007-2 and the associated Implementation Plan, Violation Risk Factors, and Violation Severity Levels were posted for a 45-day formal public comment period from June 28, 2017 through August 11, 2017, with a parallel initial ballot and non-binding poll held during the last 10 days of the comment period from August 2, 2017 through August 11, 2017. The initial ballot received 79.87% quorum, and 72.67% approval. The non-binding poll received 77.13% quorum and 69.19% of supportive opinions. There were 58 sets of responses, including comments from approximately 147 different individuals and approximately 106 companies representing all 10 industry segments.<sup>5</sup>

### **C. Final Ballot**

Proposed Reliability Standard TPL-007-2 was posted for a 10-day final ballot period on October 20, 2017 through October 30, 2017. The proposed Reliability Standard received a quorum of 88.74% and an approval rating of 73.35%.

### **D. Board of Trustees Approval**

Proposed Reliability Standard TPL-007-2 was adopted by the NERC Board of Trustees on November 9, 2017.<sup>6</sup>

---

<sup>5</sup> NERC, *Consideration of Comments*, Project 2013-03 - Geomagnetic Disturbance Mitigation, (October 2017), available at [http://www.nerc.com/pa/Stand/Project201303GeomagneticDisturbanceMitigation/Consideration\\_of\\_Comments\\_October\\_2017.pdf](http://www.nerc.com/pa/Stand/Project201303GeomagneticDisturbanceMitigation/Consideration_of_Comments_October_2017.pdf).

<sup>6</sup> NERC, *Board of Trustees Agenda Package*, Agenda Item 7b (Project 2013-03 - Geomagnetic Disturbance Mitigation), available at [http://www.nerc.com/gov/bot/Agenda%20highlights%20and%20Mintues%202013/Board\\_Open\\_Meeting\\_November\\_9\\_2017\\_Agenda\\_Package.pdf](http://www.nerc.com/gov/bot/Agenda%20highlights%20and%20Mintues%202013/Board_Open_Meeting_November_9_2017_Agenda_Package.pdf).

## **E. Implementation Plan Errata**

On January 17, 2018, the Standards Committee approved an errata change to the TPL-007-2 implementation plan.<sup>7</sup>

---

<sup>7</sup> NERC, *Standards Committee Conference Call*, Agenda Item 6 (Project 2013-03 TPL-007-2 Errata), available at [http://www.nerc.com/comm/SC/Agenda%20Highlights%20and%20Minutes/Standards\\_Committee\\_Agenda\\_Package\\_January\\_2018.pdf](http://www.nerc.com/comm/SC/Agenda%20Highlights%20and%20Minutes/Standards_Committee_Agenda_Package_January_2018.pdf).

## **Complete Record of Development**

# Project 2013-03 Geomagnetic Disturbance Mitigation

Related Files

## Status

A 10-day final ballot for **TPL-007-2 - Transmission System Planned Performance for Geomagnetic Disturbance Events concluded at 8 p.m. Eastern, Monday, October 30, 2017**. The voting results can be accessed via the links below. The standard will be submitted to the Board of Trustees for adoption and then filed with the appropriate regulatory authorities.

## Background:

On September 22, 2016, FERC issued Order No. 830 approving Reliability Standard TPL-007-1 – Transmission System Planned Performance for Geomagnetic Disturbance Events. In the order, FERC directed NERC to develop certain modifications to the Standard, or to develop other new or revised Standards. The revisions include:

- Modify the benchmark GMD event definition used for GMD Vulnerability Assessments;
- Make related modifications to requirements pertaining to transformer thermal impact assessments;
- Require collection of GMD-related data. NERC is directed to make data available; and
- Require deadlines for Corrective Action Plans (CAPs) and GMD mitigating actions.

FERC established a deadline of 18 months from the effective date of Order No. 830 for completing the revisions, which is May 2018.

Standard Affected: **TPL-007-1** - Transmission System Planned Performance for Geomagnetic Disturbance Events

## Purpose/Industry Need:

Project 2013-03 will develop reliability standards to mitigate the risk of instability, uncontrolled separation, and Cascading as a result of geomagnetic disturbances (GMDs) through application of Operating Procedures and strategies that address potential impacts identified in a registered entity's assessment as directed in FERC Order 779 and FERC Order No. 830.

While the impacts of space weather are complex and depend on numerous factors, space weather has demonstrated the potential to effect the reliable operation of the Bulk-Power System. During a GMD event, geomagnetically-induced current (GIC) flow in transformers may cause half-cycle saturation, which can increase absorption of Reactive Power, generate harmonic currents, and cause transformer hot spot heating. Increased transformer Reactive Power absorption and harmonic currents associated with GMD events can also cause protection system Misoperation and loss of Reactive Power sources, the combination of which can lead to voltage collapse.

Draft	Action	Dates	Results	Consideration of Comments
<b>The Standards Committee approved the revised Implementation Plan on January 17, 2018.</b>				
<b>Revised</b> <b>Implementation Plan</b> <b>Clean (40)   Redline to Last</b> <b>Posted (41)</b>				
<b>Final Draft</b> <b>TPL-007-2</b> <b>Clean (25)   Redline to</b> <b>Last Posted (26)</b> <b>Redline to Last Approved</b> <b>(27)</b>	Final Ballot  Info (39)  Vote	10/20/17 - 10/30/17		

<p><b>Implementation Plan Clean (28)   Redline to Last Posted (29)</b></p> <p><b>Supporting Materials</b></p> <p><b>Supplemental GMD Event White Paper Clean (30)   Redline to Last Posted (31)</b></p> <p><b>Thermal Screening Criterion White Paper Clean (32)   Redline to Last Posted (33)</b></p> <p><b>Transformer Thermal Impact Assessment White Paper Clean (34)   Redline to Last Posted (35)</b></p> <p><b>VRF/VSL Justification Clean (36)   Redline to Last Posted (37)</b></p> <p><b>Consideration of Directives (38)</b></p>			Ballot Results	
<p><b>Draft 1</b></p> <p><b>TPL-007-2 Clean (8)   Redline to Last Approved (9)</b></p> <p><b>Implementation Plan (10)</b></p> <p><b>Supporting Materials</b></p> <p><b>Supplemental GMD Event White Paper (11)</b></p> <p><b>Thermal Screening Criterion White Paper Clean (12)   Redline (13)</b></p> <p><b>Transformer Thermal Impact Assessment White Paper</b></p>	<p>Initial Ballot and Non-binding Poll</p> <p>Updated Info (19)</p> <p>Info (20)</p> <p>Vote</p>	08/02/17 – 08/11/17	Ballot Results (21) <p>Non-binding Poll Results (22)</p>	
	<p>Comment Period</p> <p>Info (23)</p> <p>Submit Comments</p>	06/28/17 – 08/11/17	Comments Received	Consideration of Comments (24)
	<p>Join Ballot Pools</p>	06/28/17 – 07/27/17		
	<p>Info</p> <p>Send RSAW feedback to: <a href="mailto:RSAWfeedback@nerc.net">RSAWfeedback@nerc.net</a></p>	07/25/17 - 08/25/17		

<p>Clean (14)   Redline (15)</p> <p>Unofficial Comment Form (Word) (16)</p> <p>VRF/VSL Justification (17)</p> <p>Consideration of Directives (18)</p> <p>Draft Reliability Standard Audit Worksheet (RSAW) Clean   Redline to Last Posted</p>				
<p>The Standards Committee accepted the Standards Authorization Request on March 16, 2017.</p>				
<p>Revised Standard Authorization Request Clean (6)   Redline (7)</p>		<p>03/17/17</p>		
<p>Standard Authorization Request (1)</p> <p>Supporting Materials</p> <p>Unofficial Comment Form (Word) (2)</p>	<p>Informal Comment Period</p> <p>Info (3)</p> <p>Submit Comments</p>	<p>12/16/16 – 01/20/17</p>	<p>Comments Received (4)</p>	<p>Consideration of Comments (5)</p>

## Standards Authorization Request Form

When completed, email this form to:  
[sarcomm@nerc.com](mailto:sarcomm@nerc.com)

NERC welcomes suggestions to improve the reliability of the bulk power system through improved reliability standards. Please use this form to submit your request to propose a new or a revision to a NERC's Reliability Standard.

### Request to propose a new or a revision to a Reliability Standard

Title of Proposed Standard(s):	Modifications to Geomagnetic Disturbance Standards		
Date Submitted:	December 1, 2016		
SAR Requester Information			
Name:	Frank Koza		
Organization:	PJM Interconnection / Project 2013-03 SDT Chair		
Telephone:	610-666-4228	E-mail:	frank.koza@pjm.com
SAR Type (Check as many as applicable)			
<input checked="" type="checkbox"/> New Standard	<input type="checkbox"/> Withdrawal of existing Standard		
<input checked="" type="checkbox"/> Revision to existing Standard	<input type="checkbox"/> Urgent Action		

### SAR Information

Purpose (Describe what the standard action will achieve in support of Bulk Electric System reliability.):

The goal of this project is to address the Federal Energy Regulatory Commission (Commission) directives contained in Order No. 830 by modifying **TPL-007-1 - Transmission System Planned Performance for Geomagnetic Disturbance Events** and the benchmark GMD event used in GMD Vulnerability Assessments or by developing an equally efficient and effective alternative.

Industry Need (What is the industry problem this request is trying to solve?):

On September 22, 2016, the Commission issued Order No. 830 approving TPL-007-1. In the order, the Commission directed NERC to develop certain modifications to the Standard, including:

- Modify the benchmark GMD event definition used for GMD Vulnerability Assessments;
- Make related modifications to requirements pertaining to transformer thermal impact assessments;



## SAR Information

- Require collection of GMD-related data, and for NERC to make it publicly available; and
- Require deadlines for Corrective Action Plans (CAPs) and GMD mitigating actions.

The Commission established a deadline of 18 months from the effective date of Order No. 830 for completing the revisions, which is May 29, 2018.

## Brief Description (Provide a paragraph that describes the scope of this standard action.)

The Standards Drafting Team (SDT) shall develop modifications to TPL-007-1 and the benchmark GMD event that address Commission directives from Order No. 830. The work will include development of Violation Risk Factors, Violation Severity Levels, and an Implementation Plan for the modified standards within the deadline established by the Commission in Order No. 830.

Detailed Description (Provide a description of the proposed project with sufficient details for the standard drafting team to execute the SAR. Also provide a justification for the development or revision of the standard, including an assessment of the reliability and market interface impacts of implementing or not implementing the standard action.)

The SDT shall address each of the Order No. 830 directives by developing modifications to requirements in TPL-007-1 and related material, or the SDT shall develop an equally efficient and effective alternative. To address concerns identified in Order No. 830, the Commission directed the following:

**Benchmark GMD Event**

- *[T]he Commission, as proposed in the NOPR, directs NERC to develop revisions to the benchmark GMD event definition so that the reference peak geoelectric field amplitude component is not based solely on spatially-averaged data.(P.44)*
- *Without prejudging how NERC proposes to address the Commission's directive, NERC's response to this directive should satisfy the NOPR's concern that reliance on spatially-averaged data alone does not address localized peaks that could potentially affect the reliable operation of the Bulk-Power System. (P.47)*

**Transformer Thermal Impact Assessment**

- *Consistent with our determination above regarding the reference peak geoelectric field amplitude value, the Commission directs NERC to revise Requirement R6 to require registered entities to apply spatially averaged and non-spatially averaged peak geoelectric field values, or some equally efficient and effective alternative, when conducting thermal impact assessments. (P.65)*

**Collection of GMD Data**

- *The Commission ... adopts the NOPR proposal in relevant part and directs NERC to develop revisions to Reliability Standard TPL-007-1 to require responsible entities to collect GIC monitoring and magnetometer data as necessary to enable model validation and situational awareness, including from any devices that must be added to meet this need. The NERC standard drafting team should address the criteria for collecting GIC monitoring and magnetometer data...*

SAR Information

*and provide registered entities with sufficient guidance in terms of defining the data that must be collected.... (P.88)*

- *Each responsible entity that is a transmission owner should be required to collect necessary GIC monitoring data. However, a transmission owner should be able to apply for an exemption from the GIC monitoring data collection requirement if it demonstrates that little or no value would be added to planning and operations. (P.91)*
- *NERC may also propose to incorporate the GIC monitoring and magnetometer data collection requirements in a different Reliability Standard....(P.91)*

**Deadlines for Corrective Action Plans and Mitigations**

- *The Commission directs NERC to modify Reliability Standard TPL-007-1 to include a deadline of one year from the completion of the GMD Vulnerability Assessments to complete the development of corrective action plans. (P.101)*
- *The Commission also directs NERC to modify Reliability Standard TPL-007-1 to include a two-year deadline after the development of the corrective action plan to complete the implementation of non-hardware mitigation and four-year deadline to complete hardware mitigation.... The Commission agrees that NERC should consider extensions of time on a case-by-case basis. (P.102)*

Reliability Functions

The Standard will Apply to the Following Functions (Check each one that applies.)

<input type="checkbox"/> Regional Reliability Organization	Conducts the regional activities related to planning and operations, and coordinates activities of Responsible Entities to secure the reliability of the Bulk Electric System within the region and adjacent regions.
<input type="checkbox"/> Reliability Coordinator	Responsible for the real-time operating reliability of its Reliability Coordinator Area in coordination with its neighboring Reliability Coordinator’s wide area view.
<input type="checkbox"/> Balancing Authority	Integrates resource plans ahead of time, and maintains load-interchange-resource balance within a Balancing Authority Area and supports Interconnection frequency in real time.
<input type="checkbox"/> Interchange Authority	Ensures communication of interchange transactions for reliability evaluation purposes and coordinates implementation of valid and balanced interchange schedules between Balancing Authority Areas.
<input checked="" type="checkbox"/> Planning Coordinator	Assesses the longer-term reliability of its Planning Coordinator Area.

Reliability Functions	
<input type="checkbox"/> Resource Planner	Develops a >one year plan for the resource adequacy of its specific loads within a Planning Coordinator area.
<input checked="" type="checkbox"/> Transmission Planner	Develops a >one year plan for the reliability of the interconnected Bulk Electric System within its portion of the Planning Coordinator area.
<input type="checkbox"/> Transmission Service Provider	Administers the transmission tariff and provides transmission services under applicable transmission service agreements (e.g., the pro forma tariff).
<input checked="" type="checkbox"/> Transmission Owner	Owns and maintains transmission facilities.
<input type="checkbox"/> Transmission Operator	Ensures the real-time operating reliability of the transmission assets within a Transmission Operator Area.
<input type="checkbox"/> Distribution Provider	Delivers electrical energy to the End-use customer.
<input checked="" type="checkbox"/> Generator Owner	Owns and maintains generation facilities.
<input type="checkbox"/> Generator Operator	Operates generation unit(s) to provide real and Reactive Power.
<input type="checkbox"/> Purchasing-Selling Entity	Purchases or sells energy, capacity, and necessary reliability-related services as required.
<input type="checkbox"/> Market Operator	Interface point for reliability functions with commercial functions.
<input type="checkbox"/> Load-Serving Entity	Secures energy and transmission service (and reliability-related services) to serve the End-use Customer.

Reliability and Market Interface Principles	
Applicable Reliability Principles (Check all that apply).	
<input checked="" type="checkbox"/>	1. Interconnected bulk power systems shall be planned and operated in a coordinated manner to perform reliably under normal and abnormal conditions as defined in the NERC Standards.
<input type="checkbox"/>	2. The frequency and voltage of interconnected bulk power systems shall be controlled within defined limits through the balancing of real and Reactive Power supply and demand.
<input checked="" type="checkbox"/>	3. Information necessary for the planning and operation of interconnected bulk power systems shall be made available to those entities responsible for planning and operating the systems reliably.
<input type="checkbox"/>	4. Plans for emergency operation and system restoration of interconnected bulk power systems shall be developed, coordinated, maintained and implemented.
<input type="checkbox"/>	5. Facilities for communication, monitoring and control shall be provided, used and maintained for the reliability of interconnected bulk power systems.

**Reliability and Market Interface Principles**

<input type="checkbox"/>	6. Personnel responsible for planning and operating interconnected bulk power systems shall be trained, qualified, and have the responsibility and authority to implement actions.
<input checked="" type="checkbox"/>	7. The security of the interconnected bulk power systems shall be assessed, monitored and maintained on a wide area basis.
<input type="checkbox"/>	8. Bulk power systems shall be protected from malicious physical or cyber attacks.
Does the proposed Standard comply with all of the following Market Interface Principles?	
Enter (yes/no)	
1. A reliability standard shall not give any market participant an unfair competitive advantage.	YES
2. A reliability standard shall neither mandate nor prohibit any specific market structure.	YES
3. A reliability standard shall not preclude market solutions to achieving compliance with that standard.	YES
4. A reliability standard shall not require the public disclosure of commercially sensitive information. All market participants shall have equal opportunity to access commercially non-sensitive information that is required for compliance with reliability standards.	YES

**Related Standards**

Standard No.	Explanation

**Related SARs**

SAR ID	Explanation

Regional Variances	
Region	Explanation
FRCC	
MRO	
NPCC	
RF	
SERC	
SPP RE	
Texas RE	
WECC	

# Unofficial Comment Form

## Project 2013-03 Geomagnetic Disturbance Mitigation Standard Authorization Request

**DO NOT** use this form for submitting comments. Use the [electronic form](#) to submit comments on the Standards Authorization Request (SAR). The electronic comment form must be completed by **8:00 p.m. Eastern, Friday, January 20, 2017**.

Documents and information about this project are available on the [project page](#). If you have any questions, contact Standards Developer, [Mark Olson](#) (via email), or at (404) 446-9760.

### Background Information

On September 22, 2016, the Federal Energy Regulatory Commission (FERC) issued Order No. 830 approving Reliability Standard TPL-007-1 - Transmission System Planned Performance for Geomagnetic Disturbance Events. In the order, FERC directed NERC to develop certain modifications to the Standard, including:

- Modify the benchmark GMD event definition used for GMD Vulnerability Assessments;
- Make related modifications to requirements pertaining to transformer thermal impact assessments;
- Require collection of GMD-related data, and for NERC to make it publicly available; and
- Require deadlines for Corrective Action Plans (CAPs) and GMD mitigating actions.

FERC established a deadline of 18 months from the effective date of Order No. 830 for completing the revisions, which is May 2018.

The standard drafting team (SDT) developed the SAR to specifically address the directives in Order No. 830. The SAR is posted for stake holder comment to obtain input for the SDT on whether changes to the SAR are needed to address the directives in Order No. 830.

## Questions

You do not have to answer all questions. Enter comments in simple text format. Bullets, numbers, and special formatting will not be retained.

1. Do you agree with the proposed scope for Project 2013-03 as described in the SAR? If you do not agree, or if you agree but have comments or suggestions for the project scope please provide your recommendation and explanation.

- Yes  
 No

Comments:

2. Provide any additional comments for the Standards Drafting Team (SDT) to consider, if desired.

- Yes  
 No

Comments:

# Standards Announcement

## Project 2013-03 Geomagnetic Disturbance Mitigation Standards Authorization Request

Informal Comment Period Open through January 20, 2017

### [Now Available](#)

A 30-day informal comment period for the **Project 2013-03 Geomagnetic Disturbance Mitigation Standards Authorization Request (SAR)**, is open through **8 p.m. Eastern, Friday, January 20, 2017**.

### Commenting

Use the [electronic form](#) to submit comments on the SAR. If you experience any difficulties using the electronic form, contact [Nasheema Santos](#). An unofficial Word version of the comment form is posted on the [project page](#).

*If you are having difficulty accessing the SBS due to a forgotten password, incorrect credential error messages, or system lock-out, contact NERC IT support directly at <https://support.nerc.net/> (Monday – Friday, 8 a.m. - 5 p.m. Eastern).*

- *Passwords expire every **6 months** and must be reset.*
- *The SBS **is not** supported for use on mobile devices.*
- *Please be mindful of ballot and comment period closing dates. We ask to **allow at least 48 hours** for NERC support staff to assist with inquiries. Therefore, it is recommended that users try logging into their SBS accounts **prior to the last day** of a comment/ballot period.*

### Next Steps

The drafting team will review all responses received during the comment period and determine the next steps of the project.

For more information on the Standards Development Process, refer to the [Standard Processes Manual](#).

For more information or assistance, contact Senior Standards Developer, [Mark Olson](#) (via email) or at (404) 446-9760.

North American Electric Reliability Corporation  
3353 Peachtree Rd, NE  
Suite 600, North Tower



Atlanta, GA 30326  
404-446-2560 | [www.nerc.com](http://www.nerc.com)

## Comment Report

**Project Name:** 2013-03 Geomagnetic Disturbance Mitigation SAR  
Comment Period Start Date: 12/16/2016  
Comment Period End Date: 1/20/2017  
Associated Ballots:

There were 21 sets of responses, including comments from approximately 21 different people from approximately 19 companies representing 8 of the Industry Segments as shown in the table on the following pages.

## **Questions**

- 1. Do you agree with the proposed scope for Project 2013-03 as described in the SAR? If you do not agree, or if you agree but have comments or suggestions for the project scope please provide your recommendation and explanation.**
- 2. Provide any additional comments for the Standards Drafting Team (SDT) to consider, if desired.**

Organization Name	Name	Segment(s)	Region	Group Name	Group Member Name	Group Member Organization	Group Member Segment(s)	Group Member Region
ACES Power Marketing	Brian Van Gheem	6	NA - Not Applicable	ACES Standards Collaborators	Bob Solomon	Hoosier Energy Rural Electric Cooperative, Inc.	1	RF
					Karl Kohlrus	Prairie Power, Inc.	1,3	SERC
					Shari Heino	Brazos Electric Power Cooperative, Inc.	1,5	Texas RE
					Tara Lightner	Sunflower Electric Power Corporation	1	SPP RE
					Mark Ringhausen	Old Dominion Electric Cooperative	3,4	SERC
					John Shaver	Arizona Electric Power Cooperative, Inc.	1	WECC
					Bill Hutchison	Southern Illinois Power Cooperative	1	SERC
					Scott Brame	North Carolina Electric Membership Corporation	3,4,5	SERC
					Bill Hutchison	Southern Illinois Power Cooperative	1,4	RF
					Bill Hutchison	Southern Illinois Power Cooperative	1,4	RF
Duke Energy	Colby Bellville	1,3,5,6	FRCC,RF,SERC	Duke Energy	Doug Hils	Duke Energy	1	RF
					Lee Schuster	Duke Energy	3	FRCC
					Dale Goodwine	Duke Energy	5	SERC
					Greg Cecil	Duke Energy	6	RF
Seattle City Light	Ginette Lacasse	1,3,4,5,6	WECC	Seattle City Light Ballot	Pawel Krupa	Seattle City Light	1	WECC

				Body	Hao Li	Seattle City Light	4	WECC
					Bud (Charles) Freeman	Seattle City Light	6	WECC
					Mike Haynes	Seattle City Light	5	WECC
					Michael Watkins	Seattle City Light	1,4	WECC
					Faz Kasraie	Seattle City Light	5	WECC
					John Clark	Seattle City Light	6	WECC
					Tuan Tran	Seattle City Light	3	WECC
					Laurie Hammack	Seattle City Light	3	WECC
Southern Company - Southern Company Services, Inc.	Marsha Morgan	1,3,5,6	SERC	Southern Company	Katherine Prewitt	Southern Company Services, Inc	1	SERC
					Jennifer Sykes	Southern Company Generation and Energy Marketing	6	SERC
					R Scott Moore	Alabama Power Company	3	SERC
					William Shultz	Southern Company Generation	5	SERC
Lower Colorado River Authority	Michael Shaw	1,5,6		LCRA Compliance	Teresa Cantwell	LCRA	1	Texas RE
					Dixie Wells	LCRA	5	Texas RE
					Michael Shaw	LCRA	6	Texas RE
Northeast Power Coordinating Council	Ruida Shu	1,2,3,4,5,6,7,10	NPCC	RSC no Dominion and OPG	Paul Malozewski	Hydro One.	1	NPCC
					Guy Zito	Northeast Power Coordinating Council	NA - Not Applicable	NPCC
					Randy MacDonald	New Brunswick Power	2	NPCC
					Wayne Sipperly	New York Power Authority	4	NPCC

					Glen Smith	Entergy Services	4	NPCC
					Brian Robinson	Utility Services	5	NPCC
					Bruce Metruck	New York Power Authority	6	NPCC
					Alan Adamson	New York State Reliability Council	7	NPCC
					Edward Bedder	Orange & Rockland Utilities	1	NPCC
					David Burke	UI	3	NPCC
					Michele Tondalo	UI	1	NPCC
					Sylvain Clermont	Hydro Quebec	1	NPCC
					Si Truc Phan	Hydro Quebec	2	NPCC
					Helen Lainis	IESO	2	NPCC
					Laura Mcleod	NB Power	1	NPCC
					Michael Forte	Con Edison	1	NPCC
					Quintin Lee	Eversource Energy	1	NPCC
					Kelly Silver	Con Edison	3	NPCC
					Peter Yost	Con Edison	4	NPCC
					Brian O'Boyle	Con Edison	5	NPCC
					Greg Campoli	NY-ISO	2	NPCC
					Kathleen Goodman	ISO-NE	2	NPCC
					Silvia Parada Mitchell	NextEra Energy, LLC	4	NPCC
					Michael Schiavone	National Grid	1	NPCC
					Michael Jones	National Grid	3	NPCC
Midwest Reliability Organization	Russel Mountjoy	10		MRO NSRF	Joseph DePoorter	Madison Gas & Electric	3,4,5,6	MRO
					Larry Heckert	Alliant Energy	4	MRO
					Amy Casucelli	Xcel Energy	1,3,5,6	MRO
					Chuck Lawrence	American Transmission	1	MRO

						Company		
					Michael Brytowski	Great River Energy	1,3,5,6	MRO
					Jodi Jensen	Western Area Power Administratino	1,6	MRO
					Kayleigh Wilkerson	Lincoln Electric System	1,3,5,6	MRO
					Mahmood Safi	Omaha Public Power District	1,3,5,6	MRO
					Brad Parret	Minnesota Power	1,5	MRO
					Terry Harbour	MidAmerican Energy Company	1,3	MRO
					Tom Breene	Wisconsin Public Service	3,5,6	MRO
					Jeremy Volls	Basin Electric Power Coop	1	MRO
					Kevin Lyons	Central Iowa Power Cooperative	1	MRO
					Mike Morrow	Midcontinent Independent System Operator	2	MRO
Southwest Power Pool, Inc. (RTO)	Shannon Mickens	2	SPP RE	SPP Standards Review Group	Shannon Mickens	Southwest Power Pool Inc.	2	SPP RE
					James Nail	Independence Power and Light	3	SPP RE
					Allan George	Sunflower Electric Power Corp	1	SPP RE
					Jonathan Hayes	Southwest Power Pool Inc.	2	SPP RE

1. Do you agree with the proposed scope for Project 2013-03 as described in the SAR? If you do not agree, or if you agree but have comments or suggestions for the project scope please provide your recommendation and explanation.

David Jendras - Ameren - Ameren Services - 1,3,6

Answer No

Document Name

Comment

The proposed revision to standard TPL-007-1 to address localized peaks in GMD events and not rely solely on the spatially-averaged data has the potential to impact much more of the transmission system and many more EHV Y-connected transformers than we had previously estimated. It is unknown at this time how the SDT will modify the standard to include this FERC mandated revision, but this would be a major concern for TOs.

It appears that Ameren as a TO will be required to install GIC monitoring equipment and magnetometers, collect data from these devices, and make the data available to those that have a need for the information. Details are still to be determined by the SDT, with the cost to install such equipment and maintain data is unknown.

Although the FERC directive allows for TOs to apply for an exemption to collect necessary GIC monitoring data, exemption criteria has not been proposed to determine if the exemption would or would not be allowed in a particular case. Regardless, because of our location in the Midwest and because of the number of 345 kV lines and EHV Y-connected transformers connected to the Ameren system, it is unlikely that Ameren would be allowed an exemption from installing monitoring equipment and collecting the GIC data, regardless of our southerly location in relation to the geomagnetic north pole.

Due to the fact that FERC is mandating these modifications, we are concerned that input from industry on the drafting of the revised standard would be given minimal consideration.

Likes 0

Dislikes 0

Response

Russel Mountjoy - Midwest Reliability Organization - 10, Group Name MRO NSRF

Answer Yes

Document Name

Comment

The NSRF agrees with the proposed scope for Project 2013-03 SAR but would like to make several suggestions that will benefit the reliable operation of the BES. If the standard drafting team plans to incorporate real-time reliability monitoring and analysis to satisfy the GMD monitoring requirements, we



suggest the SDT add Transmission Operator (TOP) as an applicable Reliability Function in the SAR.

Rationale

FERC gives NERC the option to incorporate the GMD monitoring data collection in another reliability standard. The TOP is the responsible entity to complete real-time reliability monitoring.

*“NERC may also propose to incorporate the GIC monitoring and magnetometer data collection requirements in a different Reliability Standard (e.g., real-time reliability monitoring and analysis capabilities as part of the TOP Reliability Standards).” (FERC Order 830, P.91) .*

Likes 0

Dislikes 0

**Response**

**Aaron Cavanaugh - Bonneville Power Administration - 1,3,5,6 - WECC**

**Answer** Yes

**Document Name**

**Comment**

BPA would like to know if the model validation encompasses equipment and system models for accurate GIC current determination (like transformer behavior). BPA would also like to know if the model validation encompass hysteresis curves for VAR consumption determination? BPA believes the model should contain both.

Likes 0

Dislikes 0

**Response**

**Ginette Lacasse - Seattle City Light - 1,3,4,5,6 - WECC, Group Name Seattle City Light Ballot Body**

**Answer** Yes

**Document Name**

**Comment**

Our subject matter experts do not believe that collected data should be available to the public. Or clearly define what is meant by "publicly available" and what specifically can be available.

Likes 0

Dislikes 0

Response	
Brian Van Gheem - ACES Power Marketing - 6 - NA - Not Applicable, Group Name ACES Standards Collaborators	
Answer	Yes
Document Name	
Comment	
<p>(1) We believe the proposed scope captures the directives identified in FERC Order No. 830. However, we believe several references to the FERC Order are taken out of context, and should be removed from the SAR's Detailed Description Section. The Commission wants GIC monitoring and magnetometer data to be gathered through collaboration with academia and government agencies. The reference to include "...any device that must be added..." could misdirect the SDT from the Commission's intentions. We recommend the removal of this particular reference to limit the scope of data collection.</p> <p>(2) We feel the FERC directive references should be mapped to existing requirements to identify proposed changes. For example, we recommend adding a reference to Requirement R3 when listing the directives associated with Benchmark Events. Likewise, when listing directives for Transformer Thermal Impact Assessment or Corrective Action Plans, Requirement R6 and Requirement R7 should be included as references, respectively.</p> <p>(3) We question the addition of a reference to move the data collection of GIC monitoring and magnetometer data to a different Reliability Standard. We feel this inclusion opens the door to a Commission suggestion to incorporate data collection as part of real-time reliability monitoring and analysis and relocated to the TOP Reliability Standards. We feel that if such data was required for real-time operations, it likely would have been incorporated in NERC Reliability Standard EOP-010-1, as part of emergency Geomagnetic Disturbance Operations. We recommend the removal of this reference to focus the scope of this project on TPL-007.</p> <p>(4) The SAR briefly lists the development of an implementation plan, although does not elaborate on what may change within the SAR's Detailed Description Section. While the current five year implementation plan takes effect starting July 2017, we feel a significant portion of the implementation plan will pass by the time the Commission approves the work of this SDT. We recommend the addition of a reference within the SAR's Detailed Description Section to incorporate modifications to the implementation plan that accounts for the transition away from the current implementation plane. We believe the transition period should not be less than 18 months to accommodate an impacted entity's effort to implement modeling and software changes, additional resource procurements, and quality assurance of assessments.</p>	
Likes	0
Dislikes	0

Response	
Ruida Shu - Northeast Power Coordinating Council - 1,2,3,4,5,6,7,10 - NPCC, Group Name RSC no Dominion and OPG	
Answer	Yes
Document Name	
Comment	
NPCC RSC support the proposed scope for Project 2013-03.	
Likes	0
Dislikes	0

**Response**

**Karie Barczak - DTE Energy - Detroit Edison Company - 3,4,5**

**Answer** Yes

**Document Name**

**Comment**

Likes 0

Dislikes 0

**Response**

**Jeffrey DePriest - DTE Energy - Detroit Edison Company - 3,4,5**

**Answer** Yes

**Document Name**

**Comment**

Likes 0

Dislikes 0

**Response**

**Tho Tran - Oncor Electric Delivery - 1 - Texas RE**

**Answer** Yes

**Document Name**

**Comment**

Likes 0

Dislikes 0

**Response**

**Sean Bodkin - Dominion - Dominion Resources, Inc. - 3,5,6**

**Answer** Yes

**Document Name**

**Comment**

Likes 0

Dislikes 0

**Response****RoLynda Shumpert - SCANA - South Carolina Electric and Gas Co. - 1,3,5,6 - SERC****Answer**

Yes

**Document Name****Comment**

Likes 0

Dislikes 0

**Response****Thomas Foltz - AEP - 3,5****Answer**

Yes

**Document Name****Comment**

Likes 0

Dislikes 0

**Response****Laura Nelson - IDACORP - Idaho Power Company - 1****Answer**

Yes

**Document Name****Comment**

Likes 0

Dislikes 0

**Response**

**John Merrell - Tacoma Public Utilities (Tacoma, WA) - 1,3,4,5,6**

**Answer** Yes

**Document Name**

**Comment**

Likes 0

Dislikes 0

**Response**

**Colby Bellville - Duke Energy - 1,3,5,6 - FRCC,SERC,RF, Group Name Duke Energy**

**Answer** Yes

**Document Name**

**Comment**

Likes 0

Dislikes 0

**Response**

**Shannon Mickens - Southwest Power Pool, Inc. (RTO) - 2 - SPP RE, Group Name SPP Standards Review Group**

**Answer** Yes

**Document Name**

**Comment**

Likes 0

Dislikes 0

**Response**

**Rachel Coyne - Texas Reliability Entity, Inc. - 10**

**Answer** Yes

**Document Name**

**Comment**

Likes 0

Dislikes 0

**Response**

**Teresa Cantwell - Lower Colorado River Authority - 1,5,6**

**Answer**

Yes

**Document Name**

**Comment**

Likes 0

Dislikes 0

**Response**

**Michael Shaw - Lower Colorado River Authority - 1,5,6, Group Name LCRA Compliance**

**Answer**

**Document Name**

2013-03\_GMD\_SAR\_Unofficial\_Comment\_Form\_121516.docx

**Comment**

Likes 0

Dislikes 0

**Response**

**2. Provide any additional comments for the Standards Drafting Team (SDT) to consider, if desired.**

**Brian Van Gheem - ACES Power Marketing - 6 - NA - Not Applicable, Group Name ACES Standards Collaborators**

**Answer**

**Document Name**

**Comment**

(1) We believe the SDT should collaborate its activities with existing industry technical groups, including the NERC Geomagnetic Disturbance Task Force, when designing GIC monitoring and magnetometer data collection criteria. We propose limiting the focus of this SAR to GIC monitoring and magnetometer data collection, and allow NERC and these other groups to address how such data will be shared publicly. We fear the SDT's involvement with the distribution of data could lead to unnecessary development of new Reliability Standards for currently unregistered entities and functions.

(2) We thank you for this opportunity to provide these comments.

Likes 0

Dislikes 0

**Response**

**Teresa Cantwell - Lower Colorado River Authority - 1,5,6**

**Answer**

**Document Name**

**Comment**

The approach related to the GMD benchmark definition and transformer thermal impact assessment needs to balance ease of implementation with the quality of results.

A methodology similar to that employed in PRC-002 should be utilized to limit the required number of installations of monitoring data (e.g. based on short circuit MVA or some other parameter). Not every TO should be required to install monitoring data. This may be better accomplished by rolling the monitoring requirement into another standard (e.g. PRC-002).

NERC should consider extensions of time for CAPs and/or hardware installation on a case-by-case basis.

Likes 0

Dislikes 0

**Response**

**Rachel Coyne - Texas Reliability Entity, Inc. - 10**

**Answer**

<b>Document Name</b>	
<b>Comment</b>	
Texas RE made the following observations:	
<ul style="list-style-type: none"> <li>Paragraph 91 in Order No. 830 discusses the ability for a Transmission Owner to apply for an exemption. Texas RE is concerned if the responsible entity determined in R1 is allowed to grant exemptions, many entities that are registered as a TP and TO will be able to grant itself an exemption. Texas RE recommends determining who is responsible for granting exemptions, since Order No. 830 does not specify.</li> <li>The “Industry Need” section includes details about NERC making GMD-related data publicly available, but “Detailed Description” section does not.</li> <li>In the “Collection of GMD Data” section, the SAR states that “Each responsible entity that is a transmission owner should be required to collect necessary GIC monitoring data.” However, TPL-007-1 R1 currently defines a “responsible entity” as either a TP or a PC. When updating the Standard, the SDT should avoid using “responsible entity” when referencing a TO.</li> <li>Texas RE recommends emphasizing sufficient and appropriate compliance documentation, regarding an “equally efficient and effective alternative”. An entity would be required to demonstrate efficiency and effectiveness. For the data submittal portion, there needs to be care in addressing timing as the directive included historical and new data. There is no discussion of data requirements, per se, and the content, format, or timing associated with the data.</li> </ul>	
Likes	0
Dislikes	0
<b>Response</b>	
Shannon Mickens - Southwest Power Pool, Inc. (RTO) - 2 - SPP RE, Group Name SPP Standards Review Group	
<b>Answer</b>	
<b>Document Name</b>	
<b>Comment</b>	
After reviewing the transcript associated with the Level 2 Appeal of Foundation For Resilient Societies, INC. in reference to TPL-007-1, we suggest the drafting team review and use this document as guidance throughout their modification process to the Standard. In our review, we found some similarities of concerns shared by both <b>The Foundation for Resilient Societies, INC</b> and <b>FERC Order 830</b> such as, transformer thermal impact assessments as well as data collection and how that information would be made publicly available.	
Likes	0
Dislikes	0
<b>Response</b>	
Ginette Lacasse - Seattle City Light - 1,3,4,5,6 - WECC, Group Name Seattle City Light Ballot Body	
<b>Answer</b>	
<b>Document Name</b>	



**Comment**

Thank you for seeking our input in advance.

Likes 0

Dislikes 0

**Response**

**Marsha Morgan - Southern Company - Southern Company Services, Inc. - 1,3,5,6 - SERC, Group Name Southern Company**

**Answer****Document Name****Comment**

Because commercially available models and tools do not currently exist for performing transformer thermal impact assessments, we ask the SDT to continue considering suitable alternates (e.g., look up tables, development of flowcharts or processes).

Also, we ask the SDT to provide clarification of the event included in Table 1 - Steady State Planning Events. In particular, with regards to protection system misoperation due to harmonics during a GMD event, please provide clarification as to what is expected. Will this require that large scale harmonic penetration studies be performed in order to analyze potential impact of half-cycle saturation generated harmonics on system protection and/or equipment controls? Or will engineering assessments that identify credible scenarios be sufficient?

SDT to consider that the procurement and installation of instrument transformers for the collection of GIC monitoring and magnetometer data takes months to implement. SDT to consider realistic timelines for implementation, as well as providing technical guidance for implementation of GIC measurement devices.

We ask the SDT to provide additional clarification on R2. In particular, SDT to elaborate on "maintaining System models and GIC System Models." Is R2 referring to gathering and maintaining dc and ac models (e.g., substation dc resistances, dc network data) of the system under study? Does it require having to complete a GIC analysis by R2 deadline, so that GIC system models can be produced and maintained? Please provide clarification.

Likes 0

Dislikes 0

**Response**

**David Jendras - Ameren - Ameren Services - 1,3,6**

**Answer****Document Name****Comment**

The change in deadlines for mitigation of GMD events would not be a concern in Ameren's case. Ameren is not interested in installing blocking devices to Y-connected EHV transformers. Therefore, operational solutions will provide the likely mitigations.

Likes 0

Dislikes 0

**Response**

**Aaron Cavanaugh - Bonneville Power Administration - 1,3,5,6 - WECC**

**Answer**

**Document Name**

**Comment**

BPA would like to know how the Standard Drafting Team envisions collecting the data to perform the studies. If there is no regional data collection effort similar to MOD-032, then how is it envisioned that accurate GIC studies to determine DC currents will be run? BPA believes a documented process needs to be created WECC wide (or nationally). BPA envisions the data collection included with MOD-032 to be collected every 5 years (or according to study schedule with version 2 of TPL-007). BPA's experience is that most entities are not willing to take on extra work if they do not have to.

Likes 0

Dislikes 0

**Response**

**Russel Mountjoy - Midwest Reliability Organization - 10, Group Name MRO NSRF**

**Answer**

**Document Name**

**Comment**

None

Likes 0

Dislikes 0

**Response**

**Sandra Shaffer - Berkshire Hathaway - PacifiCorp - 6**

**Answer**

**Document Name**

**Comment**

PacifiCorp supports the proposal to incorporate the GIC monitoring and magnetometer data collection requirements in a different Reliability Standard.

This separation would allow more attention to the specific upgrades already outlined in the SAR.

Likes 0

Dislikes 0

**Response**

**Jeffrey DePriest - DTE Energy - Detroit Edison Company - 3,4,5**

**Answer**

**Document Name**

**Comment**

Please consider an approach where GIC monitor locations are determined on a regional basis in order to obtain the most value from each installation and insure that all areas are covered appropriately. An individual GO/TO may not have the information needed to properly place equipment. Also, providing monitoring equipment specifications would insure that manufacturers would design, and entities would install, capable monitors that will provide reliable data.

Likes 0

Dislikes 0

**Response**

**Karie Barczak - DTE Energy - Detroit Edison Company - 3,4,5**

**Answer**

**Document Name**

**Comment**

Please consider an approach where GIC monitor locations are determined on a regional basis in order to obtain the most value from each installation and insure that all areas are covered appropriately. An individual GO/TO may not have the information needed to properly place equipment. Also, providing monitoring equipment specifications would insure that manufacturers would design, and entities would install, capable monitors that will provide reliable data.

Likes 0

Dislikes 0

**Response**

**Michael Shaw - Lower Colorado River Authority - 1,5,6, Group Name LCRA Compliance**

**Answer**

**Document Name**

2013-03\_GMD\_SAR\_Unofficial\_Comment\_Form\_121516.docx

**Comment**

Likes 0

Dislikes 0

**Response**

## Consideration of Comments

**Project Name:** 2013-03 Geomagnetic Disturbance Mitigation SAR  
Comment Period Start Date: 12/16/2016  
Comment Period End Date: 1/20/2017

There were 21 sets of responses, including comments from approximately 21 different people from approximately 19 companies representing 8 of the Industry Segments as shown in the table on the following pages.

All comments submitted can be reviewed in their original format on the [project page](#).

If you feel that your comment has been overlooked, please let us know immediately. Our goal is to give every comment serious consideration in this process. If you feel there has been an error or omission, you can contact the Director of Standards Development, [Steve Noess](#) (via email) or at (404) 446-9691.

## Questions

- 1. Do you agree with the proposed scope for Project 2013-03 as described in the SAR? If you do not agree, or if you agree but have comments or suggestions for the project scope please provide your recommendation and explanation.**
- 2. Provide any additional comments for the Standards Drafting Team (SDT) to consider, if desired.**

### **The Industry Segments are:**

- 1 — Transmission Owners
- 2 — RTOs, ISOs
- 3 — Load-serving Entities
- 4 — Transmission-dependent Utilities
- 5 — Electric Generators
- 6 — Electricity Brokers, Aggregators, and Marketers
- 7 — Large Electricity End Users
- 8 — Small Electricity End Users
- 9 — Federal, State, Provincial Regulatory or other Government Entities
- 10 — Regional Reliability Organizations, Regional Entities

Organization Name	Name	Segment(s)	Region	Group Name	Group Member Name	Group Member Organization	Group Member Segment(s)	Group Member Region
ACES Power Marketing	Brian Van Gheem	6	NA - Not Applicable	ACES Standards Collaborators	Bob Solomon	Hoosier Energy Rural Electric Cooperative, Inc.	1	RF
					Karl Kohlrus	Prairie Power, Inc.	1,3	SERC
					Shari Heino	Brazos Electric Power Cooperative, Inc.	1,5	Texas RE
					Tara Lightner	Sunflower Electric Power Corporation	1	SPP RE
					Mark Ringhausen	Old Dominion Electric Cooperative	3,4	SERC
					John Shaver	Arizona Electric Power Cooperative, Inc.	1	WECC
					Bill Hutchison	Southern Illinois Power Cooperative	1	SERC

					Scott Brame	North Carolina Electric Membership Corporation	3,4,5	SERC
					Bill Hutchison	Southern Illinois Power Cooperative	1,4	RF
					Bill Hutchison	Southern Illinois Power Cooperative	1,4	RF
Duke Energy	Colby Bellville	1,3,5,6	FRCC,RF,SERC	Duke Energy	Doug Hils	Duke Energy	1	RF
					Lee Schuster	Duke Energy	3	FRCC
					Dale Goodwine	Duke Energy	5	SERC
					Greg Cecil	Duke Energy	6	RF
Seattle City Light	Ginette Lacasse	1,3,4,5,6	WECC	Seattle City Light Ballot Body	Pawel Krupa	Seattle City Light	1	WECC
					Hao Li	Seattle City Light	4	WECC
					Bud (Charles) Freeman	Seattle City Light	6	WECC
					Mike Haynes	Seattle City Light	5	WECC
					Michael Watkins	Seattle City Light	1,4	WECC
					Faz Kasraie	Seattle City Light	5	WECC



					John Clark	Seattle City Light	6	WECC
					Tuan Tran	Seattle City Light	3	WECC
					Laurrie Hammack	Seattle City Light	3	WECC
Southern Company - Southern Company Services, Inc.	Marsha Morgan	1,3,5,6	SERC	Southern Company	Katherine Prewitt	Southern Company Services, Inc	1	SERC
					Jennifer Sykes	Southern Company Generation and Energy Marketing	6	SERC
					R Scott Moore	Alabama Power Company	3	SERC
					William Shultz	Southern Company Generation	5	SERC
Lower Colorado River Authority	Michael Shaw	1,5,6		LCRA Compliance	Teresa Cantwell	LCRA	1	Texas RE
					Dixie Wells	LCRA	5	Texas RE
					Michael Shaw	LCRA	6	Texas RE
Northeast Power Coordinating Council	Ruida Shu	1,2,3,4,5,6,7,10	NPCC	RSC no Dominion and OPG	Paul Malozewski	Hydro One.	1	NPCC
					Guy Zito	Northeast Power	NA - Not Applicable	NPCC

	Coordinating Council		
Randy MacDonald	New Brunswick Power	2	NPCC
Wayne Sipperly	New York Power Authority	4	NPCC
Glen Smith	Entergy Services	4	NPCC
Brian Robinson	Utility Services	5	NPCC
Bruce Metruck	New York Power Authority	6	NPCC
Alan Adamson	New York State Reliability Council	7	NPCC
Edward Bedder	Orange & Rockland Utilities	1	NPCC
David Burke	UI	3	NPCC
Michele Tondalo	UI	1	NPCC
Sylvain Clermont	Hydro Quebec	1	NPCC
Si Truc Phan	Hydro Quebec	2	NPCC

					Helen Lainis	IESO	2	NPCC
					Laura Mcleod	NB Power	1	NPCC
					Michael Forte	Con Edison	1	NPCC
					Quintin Lee	Eversource Energy	1	NPCC
					Kelly Silver	Con Edison	3	NPCC
					Peter Yost	Con Edison	4	NPCC
					Brian O'Boyle	Con Edison	5	NPCC
					Greg Campoli	NY-ISO	2	NPCC
					Kathleen Goodman	ISO-NE	2	NPCC
					Silvia Parada Mitchell	NextEra Energy, LLC	4	NPCC
					Michael Schiavone	National Grid	1	NPCC
					Michael Jones	National Grid	3	NPCC
Midwest Reliability Organization	Russel Mountjoy	10		MRO NSRF	Joseph DePoorter	Madison Gas & Electric	3,4,5,6	MRO
					Larry Heckert	Alliant Energy	4	MRO
					Amy Casucelli	Xcel Energy	1,3,5,6	MRO
					Chuck Lawrence	American Transmission Company	1	MRO
					Michael Brytowski	Great River Energy	1,3,5,6	MRO

					Jodi Jensen	Western Area Power Administratino	1,6	MRO
					Kayleigh Wilkerson	Lincoln Electric System	1,3,5,6	MRO
					Mahmood Safi	Omaha Public Power District	1,3,5,6	MRO
					Brad Parret	Minnesota Power	1,5	MRO
					Terry Harbour	MidAmerican Energy Company	1,3	MRO
					Tom Breene	Wisconsin Public Service	3,5,6	MRO
					Jeremy Volls	Basin Electric Power Coop	1	MRO
					Kevin Lyons	Central Iowa Power Cooperative	1	MRO
					Mike Morrow	Midcontinent Independent System Operator	2	MRO
Southwest Power Pool, Inc. (RTO)	Shannon Mickens	2	SPP RE	SPP Standards	Shannon Mickens	Southwest Power Pool Inc.	2	SPP RE

				Review Group	James Nail	Independence Power and Light	3	SPP RE
					Allan George	Sunflower Electric Power Corp	1	SPP RE
					Jonathan Hayes	Southwest Power Pool Inc.	2	SPP RE

**1. Do you agree with the proposed scope for Project 2013-03 as described in the SAR? If you do not agree, or if you agree but have comments or suggestions for the project scope please provide your recommendation and explanation.**

**David Jendras - Ameren - Ameren Services - 1,3,6**

**Answer**

No

**Document Name**

**Comment**

The proposed revision to standard TPL-007-1 to address localized peaks in GMD events and not rely solely on the spatially-averaged data has the potential to impact much more of the transmission system and many more EHV Y-connected transformers than we had previously estimated. It is unknown at this time how the SDT will modify the standard to include this FERC mandated revision, but this would be a major concern for TOs.

It appears that Ameren as a TO will be required to install GIC monitoring equipment and magnetometers, collect data from these devices, and make the data available to those that have a need for the information. Details are still to be determined by the SDT, with the cost to install such equipment and maintain data is unknown.

Although the FERC directive allows for TOs to apply for an exemption to collect necessary GIC monitoring data, exemption criteria has not been proposed to determine if the exemption would or would not be allowed in a particular case. Regardless, because of our location in the Midwest and because of the number of 345 kV lines and EHV Y-connected transformers connected to the Ameren system, it is unlikely that Ameren would be allowed an exemption from installing monitoring equipment and collecting the GIC data, regardless of our southerly location in relation to the geomagnetic north pole.

Due to the fact that FERC is mandating these modifications, we are concerned that input from industry on the drafting of the revised standard would be given minimal consideration.

Likes 0

Dislikes 0

**Response.** Thank you for your comments. In order to address the FERC Order No. 830 directives, the SDT will consider ways to incorporate localized peak events into the existing GMD benchmark. It is too soon to know how the benchmark will change and what the impact on the industry will be. Regarding the installation of GIC monitors and magnetometers the SDT intends to coordinate technical details with the NERC GMD Task Force. There is significant industry experience on the SDT, so any requirements that are added to the standard will be discussed within the SDT and with the NERC GMD Task Force. Stakeholder input will be considered by the SDT throughout the standard development process.

**Russel Mountjoy - Midwest Reliability Organization - 10, Group Name MRO NSRF**

<b>Answer</b>	Yes
---------------	-----

<b>Document Name</b>	
----------------------	--

<b>Comment</b>
----------------

The NSRF agrees with the proposed scope for Project 2013-03 SAR but would like to make several suggestions that will benefit the reliable operation of the BES. If the standard drafting team plans to incorporate real-time reliability monitoring and analysis to satisfy the GMD monitoring requirements, we suggest the SDT add Transmission Operator (TOP) as an applicable Reliability Function in the SAR.

Rationale

FERC gives NERC the option to incorporate the GMD monitoring data collection in another reliability standard. The TOP is the responsible entity to complete real-time reliability monitoring.

*“NERC may also propose to incorporate the GIC monitoring and magnetometer data collection requirements in a different Reliability Standard (e.g., real-time reliability monitoring and analysis capabilities as part of the TOP Reliability Standards).” (FERC Order 830, P.91) .*

Likes	0
-------	---

Dislikes	0
----------	---

**Response.** Thank you for your comments. Order No. 830 directs NERC to address the collection of data from GIC detectors and magnetometers for the purpose of aiding in the validation of models used to facilitate the calculations required in TPL-007. It does not require real time data collection, but that doesn't limit entities from collecting real time data in support of system operations. If an entity's

operating procedure requires real time data collection, then that process would be documented in procedures under EOP-010 and the TOP would be an applicable entity.

**Aaron Cavanaugh - Bonneville Power Administration - 1,3,5,6 - WECC**

<b>Answer</b>	Yes
---------------	-----

<b>Document Name</b>	
----------------------	--

**Comment**

BPA would like to know if the model validation encompasses equipment and system models for accurate GIC current determination (like transformer behavior). BPA would also like to know if the model validation encompass hysteresis curves for VAR consumption determination? BPA believes the model should contain both.

Likes	0
-------	---

Dislikes	0
----------	---

**Response.** Thank you for your comments. Order No. 830 is not prescriptive regarding what kind of models would be validated using GIC and/or geomagnetic field measurements. The SDT believes the requirements should be application-neutral.

**Ginette Lacasse - Seattle City Light - 1,3,4,5,6 - WECC, Group Name Seattle City Light Ballot Body**

<b>Answer</b>	Yes
---------------	-----

<b>Document Name</b>	
----------------------	--

**Comment**

Our subject matter experts do not believe that collected data should be available to the public. Or clearly define what is meant by "publicly available" and what specifically can be available.

Likes	0
-------	---

Dislikes	0
----------	---



**Response.** Thank you for your comment. Order No. 830 is clear in directing NERC to require entities to collect GIC and magnetometer data, and for NERC to make the data publically available. The details of such a program are yet to be worked out, but will include discussions among the SDT, the NERC GMD Task Force, and NERC. In Order No. 830, FERC indicated that they were not persuaded by arguments in the record for TPL-007-1 that this data should be treated as confidential, but that entities could seek confidential treatment of their data from NERC (P 94-95). Accordingly, NERC's data collection process developed to meet Order No. 830 is expected to provide entities with the means for identifying some or all data that the entity believes should be treated as confidential.

**Brian Van Gheem - ACES Power Marketing - 6 - NA - Not Applicable, Group Name ACES Standards Collaborators**

**Answer** Yes

**Document Name**

**Comment**

(1) We believe the proposed scope captures the directives identified in FERC Order No. 830. However, we believe several references to the FERC Order are taken out of context, and should be removed from the SAR's Detailed Description Section. The Commission wants GIC monitoring and magnetometer data to be gathered through collaboration with academia and government agencies. The reference to include "...any device that must be added..." could misdirect the SDT from the Commission's intentions. We recommend the removal of this particular reference to limit the scope of data collection.

(2) We feel the FERC directive references should be mapped to existing requirements to identify proposed changes. For example, we recommend adding a reference to Requirement R3 when listing the directives associated with Benchmark Events. Likewise, when listing directives for Transformer Thermal Impact Assessment or Corrective Action Plans, Requirement R6 and Requirement R7 should be included as references, respectively.

(3) We question the addition of a reference to move the data collection of GIC monitoring and magnetometer data to a different Reliability Standard. We feel this inclusion opens the door to a Commission suggestion to incorporate data collection as part of real-time reliability monitoring and analysis and relocated to the TOP Reliability Standards. We feel that if such data was required for real-time operations, it likely would have been incorporated in NERC Reliability Standard EOP-010-1, as part of emergency Geomagnetic Disturbance Operations. We recommend the removal of this reference to focus the scope of this project on TPL-007.

(4) The SAR briefly lists the development of an implementation plan, although does not elaborate on what may change within the SAR's Detailed Description Section. While the current five year implementation plan takes effect starting July 2017, we feel a significant portion of

the implementation plan will pass by the time the Commission approves the work of this SDT. We recommend the addition of a reference within the SAR’s Detailed Description Section to incorporate modifications to the implementation plan that accounts for the transition away from the current implementation plane. We believe the transition period should not be less than 18 months to accommodate an impacted entity’s effort to implement modeling and software changes, additional resource procurements, and quality assurance of assessments.

Likes 0

Dislikes 0

**Response.** Thank you for your comments.

- (1) The FERC order discusses the option of collaborating with academia and government agencies for the collection of data, but that is not the only option provided in the order. It is understood that additional GIC detectors and magnetometers may be required and the SAR accounts for this additional option.
- (2) References to the existing standard requirements will be added to the SAR as minor editorial changes.
- (3) The SAR statement on the possibility of placing data collection requirements in another standard is from the FERC order. (paragraph 91)
- (4) It is too soon to know what additional requirements may be placed on applicable entities as a result of modifications to the existing standard. Accordingly, any statements about changes to the implementation plan are premature. The SDT believes the SAR as written provides the necessary project scope for developing an implementation plan.

**Ruida Shu - Northeast Power Coordinating Council - 1,2,3,4,5,6,7,10 - NPCC, Group Name** RSC no Dominion and OPG

**Answer** Yes

**Document Name**

**Comment**

NPCC RSC support the proposed scope for Project 2013-03.

Likes 0

Dislikes 0

**Response.** Thank you for your comment.

**Karie Barczak - DTE Energy - Detroit Edison Company - 3,4,5**

**Answer** Yes

**Document Name**

**Comment**

Likes 0

Dislikes 0

**Response**

**Jeffrey DePriest - DTE Energy - Detroit Edison Company - 3,4,5**

**Answer** Yes

**Document Name**

**Comment**

Likes 0

Dislikes 0

**Response**

**Tho Tran - Oncor Electric Delivery - 1 - Texas RE**

**Answer** Yes

**Document Name**

**Comment**

Likes 0	
Dislikes 0	
<b>Response</b>	
Sean Bodkin - Dominion - Dominion Resources, Inc. - 3,5,6	
Answer	Yes
Document Name	
<b>Comment</b>	
Likes 0	
Dislikes 0	
<b>Response</b>	
RoLynda Shumpert - SCANA - South Carolina Electric and Gas Co. - 1,3,5,6 - SERC	
Answer	Yes
Document Name	
<b>Comment</b>	
Likes 0	
Dislikes 0	
<b>Response</b>	
Thomas Foltz - AEP - 3,5	

<b>Answer</b>	Yes
<b>Document Name</b>	
<b>Comment</b>	
Likes 0	
Dislikes 0	
<b>Response</b>	
<b>Laura Nelson - IDACORP - Idaho Power Company - 1</b>	
<b>Answer</b>	Yes
<b>Document Name</b>	
<b>Comment</b>	
Likes 0	
Dislikes 0	
<b>Response</b>	
<b>John Merrell - Tacoma Public Utilities (Tacoma, WA) - 1,3,4,5,6</b>	
<b>Answer</b>	Yes
<b>Document Name</b>	
<b>Comment</b>	
Likes 0	
Dislikes 0	

**Response**

**Colby Bellville - Duke Energy - 1,3,5,6 - FRCC,SERC,RF, Group Name Duke Energy**

**Answer** Yes

**Document Name**

**Comment**

Likes 0

Dislikes 0

**Response**

**Shannon Mickens - Southwest Power Pool, Inc. (RTO) - 2 - SPP RE, Group Name SPP Standards Review Group**

**Answer** Yes

**Document Name**

**Comment**

Likes 0

Dislikes 0

**Response**

**Rachel Coyne - Texas Reliability Entity, Inc. - 10**

**Answer** Yes

**Document Name**

**Comment**

Likes 0	
Dislikes 0	
<b>Response</b>	
<b>Teresa Cantwell - Lower Colorado River Authority - 1,5,6</b>	
<b>Answer</b>	Yes
<b>Document Name</b>	
<b>Comment</b>	
Likes 0	
Dislikes 0	
<b>Response</b>	
<b>Michael Shaw - Lower Colorado River Authority - 1,5,6, Group Name LCRA Compliance</b>	
<b>Answer</b>	
<b>Document Name</b>	
<b>Comment</b>	
Likes 0	
Dislikes 0	
<b>Response</b>	

2. Provide any additional comments for the Standards Drafting Team (SDT) to consider, if desired.

Brian Van Gheem - ACES Power Marketing - 6 - NA - Not Applicable, Group Name ACES Standards Collaborators

Answer

Document Name

Comment

(1) We believe the SDT should collaborate its activities with existing industry technical groups, including the NERC Geomagnetic Disturbance Task Force, when designing GIC monitoring and magnetometer data collection criteria. We propose limiting the focus of this SAR to GIC monitoring and magnetometer data collection, and allow NERC and these other groups to address how such data will be shared publicly. We fear the SDT’s involvement with the distribution of data could lead to unnecessary development of new Reliability Standards for currently unregistered entities and functions.

(2) We thank you for this opportunity to provide these comments.

Likes 0

Dislikes 0

**Response.** Thank you for your comment. The SDT intends to collaborate its standards development activities with the NERC GMD Task Force, and where appropriate other industry technical groups. The SDT agrees that NERC and other technical groups should address issues with the public availability of collected data. The SDT is focused on developing requirements for the collection of data as specified in Order No. 830 P 88 and P 91. The SDT has clarified this in the project SAR. The process for the distribution of that data will likely be addressed outside of the revised standard.

Teresa Cantwell - Lower Colorado River Authority - 1,5,6

Answer

Document Name



**Comment**

The approach related to the GMD benchmark definition and transformer thermal impact assessment needs to balance ease of implementation with the quality of results.

A methodology similar to that employed in PRC-002 should be utilized to limit the required number of installations of monitoring data (e.g. based on short circuit MVA or some other parameter). Not every TO should be required to install monitoring data. This may be better accomplished by rolling the monitoring requirement into another standard (e.g. PRC-002).

NERC should consider extensions of time for CAPs and/or hardware installation on a case-by-case basis.

Likes 0

Dislikes 0

**Response.** Thank you for your comment. The SDT will consider these inputs during standard development. The SDT believes that there is a balance between ease of implementation and a conservative approach to potential transformer impact by means of the transformer thermal screening criteria.

The SDT will work in conjunction with the NERC GMD Task Force and other industry technical groups in the development of criteria for number and/or location of monitoring equipment.

**Rachel Coyne - Texas Reliability Entity, Inc. - 10**

**Answer**

**Document Name**

**Comment**

Texas RE made the following observations:

- Paragraph 91 in Order No. 830 discusses the ability for a Transmission Owner to apply for an exemption. Texas RE is concerned if the responsible entity determined in R1 is allowed to grant exemptions, many entities that are registered as a TP and TO will be able to

grant itself an exemption. Texas RE recommends determining who is responsible for granting exemptions, since Order No. 830 does not specify.

- The “Industry Need” section includes details about NERC making GMD-related data publicly available, but “Detailed Description” section does not.
- In the “Collection of GMD Data” section, the SAR states that “Each responsible entity that is a transmission owner should be required to collect necessary GIC monitoring data.” However, TPL-007-1 R1 currently defines a “responsible entity” as either a TP or a PC. When updating the Standard, the SDT should avoid using “responsible entity” when referencing a TO.
- Texas RE recommends emphasizing sufficient and appropriate compliance documentation, regarding an “equally efficient and effective alternative”. An entity would be required to demonstrate efficiency and effectiveness. For the data submittal portion, there needs to be care in addressing timing as the directive included historical and new data. There is no discussion of data requirements, per se, and the content, format, or timing associated with the data.

Likes 0

Dislikes 0

**Response.** Thank you for your comments.

Order No. 830 states that entities should be able to apply for exemption from data collection requirements if an entity “demonstrates that no or little value would be added to planning and operations.” The order provides flexibility for the SDT to establish the process and criteria for requesting and approving such exemptions. The SDT will be discussing the exemption process as part of its work on the revised standard.

The detailed description section of the SAR contains excerpts from the FERC order with a reference to the applicable paragraph in the order. The SDT believes that it is sufficiently clear that the intent is to make the data publicly available

The SDT will make every attempt to provide clarity as to the applicability of the requirements of the standard and will minimize the use of the term “responsible entity”.

The requirements for the collection and distribution of GIC detector and magnetometer data will be developed by the SDT. The FERC order does require both historical and new data to be provided, however historical data will be collected by NERC via a Rules of Procedure Section

1600 data request (not in scope for the standards project). The SDT does not view the Order No. 830 phrase "equally efficient and effective" to apply to compliance documentation.

**Shannon Mickens - Southwest Power Pool, Inc. (RTO) - 2 - SPP RE, Group Name SPP Standards Review Group**

**Answer**

**Document Name**

**Comment**

After reviewing the transcript associated with the Level 2 Appeal of Foundation For Resilient Societies, INC. in reference to TPL-007-1, we suggest the drafting team review and use this document as guidance throughout their modification process to the Standard. In our review, we found some similarities of concerns shared by both **The Foundation for Resilient Societies, INC** and **FERC Order 830** such as, transformer thermal impact assessments as well as data collection and how that information would be made publicly available.

Likes 0

Dislikes 0

**Response.** Thank you for your comments. The SDT is aware of Level 2 Appeal transcript. The SDT responded to comments raised by the Foundation for Resilient Societies during development of TPL-007-1.

**Ginette Lacasse - Seattle City Light - 1,3,4,5,6 - WECC, Group Name Seattle City Light Ballot Body**

**Answer**

**Document Name**

**Comment**

Thank you for seeking our input in advance.

Likes 0

Dislikes 0

**Response**

**Marsha Morgan - Southern Company - Southern Company Services, Inc. - 1,3,5,6 - SERC, Group Name** Southern Company

**Answer**

**Document Name**

**Comment**

Because commercially available models and tools do not currently exist for performing transformer thermal impact assessments, we ask the SDT to continue considering suitable alternates (e.g., look up tables, development of flowcharts or processes).

Also, we ask the SDT to provide clarification of the event included in Table 1 - Steady State Planning Events. In particular, with regards to protection system misoperation due to harmonics during a GMD event, please provide clarification as to what is expected. Will this require that large scale harmonic penetration studies be performed in order to analyze potential impact of half-cycle saturation generated harmonics on system protection and/or equipment controls? Or will engineering assessments that identify credible scenarios be sufficient?

SDT to consider that the procurement and installation of instrument transformers for the collection of GIC monitoring and magnetometer data takes months to implement. SDT to consider realistic timelines for implementation, as well as providing technical guidance for implementation of GIC measurement devices.

We ask the SDT to provide additional clarification on R2. In particular, SDT to elaborate on "maintaining System models and GIC System Models." Is R2 referring to gathering and maintaining dc and ac models (e.g., substation dc resistances, dc network data) of the system under study? Does it require having to complete a GIC analysis by R2 deadline, so that GIC system models can be produced and maintained? Please provide clarification.

Likes 0

Dislikes 0

**Response.** Thank you for your comments. The SDT has provided alternatives for conducting the transformer thermal impact assessments in the original standard and intends to continue in that mode for any modifications that may be necessary to address the FERC directives.

The SDT recognizes that detailed harmonic analyses may be beyond the capability of many applicable entities. As stated in the development of TPL-007-1, reasonable engineering judgment can be exercised to identify protection equipment that may be vulnerable to misoperation in the Benchmark GMD event and therefore, should be placed out of service in the power flow analysis. (See Project 2013-03 Consideration of Comments dated December 5, 2014, P. 16, P. 48)

To the degree that additional GIC detectors and/or magnetometers are necessary to be installed, the SDT will address the timeframe to install such devices in the implementation plan.

The intent of requirement R2 in TPL-007-1 is to require entities to maintain models necessary to perform the required analysis (both ac models for the network analysis and dc models for the GIC calculation). Requirement R2 does not specify that GIC calculations must be completed.

**David Jendras - Ameren - Ameren Services - 1,3,6**

**Answer**

**Document Name**

**Comment**

The change in deadlines for mitigation of GMD events would not be a concern in Ameren's case. Ameren is not interested in installing blocking devices to Y-connected EHV transformers. Therefore, operational solutions will provide the likely mitigations.

Likes 0

Dislikes 0

**Response** Thank you for the comment.

**Aaron Cavanaugh - Bonneville Power Administration - 1,3,5,6 - WECC**

**Answer**

**Document Name**

**Comment**

BPA would like to know how the Standard Drafting Team envisions collecting the data to perform the studies. If there is no regional data collection effort similar to MOD-032, then how is it envisioned that accurate GIC studies to determine DC currents will be run? BPA believes a documented process needs to be created WECC wide (or nationally). BPA envisions the data collection included with MOD-032 to be collected every 5 years (or according to study schedule with version 2 of TPL-007). BPA’s experience is that most entities are not willing to take on extra work if they do not have to.

Likes 0

Dislikes 0

**Response.** Thank you for your comment. As noted in development of TPL-007-1, the standard provides flexibility for various approaches to collecting the necessary data for GMD Vulnerability Assessments, including the use of regional planning groups. (See Project 2013-03 Consideration of Comments dated October 28, 2014, P. 23). The whitepapers associated with the development of TPL-007-1 address the process of performing the GIC calculations.

**Russel Mountjoy - Midwest Reliability Organization - 10, Group Name MRO NSRF**

**Answer**

**Document Name**

**Comment**

None

Likes 0

Dislikes 0

**Response**

**Sandra Shaffer - Berkshire Hathaway - PacifiCorp - 6**

<b>Answer</b>	
<b>Document Name</b>	
<b>Comment</b>	
<p>PacifiCorp supports the proposal to incorporate the GIC monitoring and magnetometer data collection requirements in a different Reliability Standard. This separation would allow more attention to the specific upgrades already outlined in the SAR.</p>	
Likes 0	
Dislikes 0	
<p><b>Response.</b> Thank you for your comment. The SDT will develop the GIC monitoring and magnetometer data collection requirements and then determine the most appropriate location for those requirements.</p>	
<p><b>Jeffrey DePriest - DTE Energy - Detroit Edison Company - 3,4,5</b></p>	
<b>Answer</b>	
<b>Document Name</b>	
<b>Comment</b>	
<p>Please consider an approach where GIC monitor locations are determined on a regional basis in order to obtain the most value from each installation and insure that all areas are covered appropriately. An individual GO/TO may not have the information needed to properly place equipment. Also, providing monitoring equipment specifications would insure that manufacturers would design, and entities would install, capable monitors that will provide reliable data.</p>	
Likes 0	
Dislikes 0	
<p><b>Response.</b> The SDT will develop the GIC monitoring and magnetometer data collection requirements and determine the most appropriate location for those requirements. The SDT will work with the NERC GMD Task Force on the issue of equipment specifications.</p>	

**Karie Barczak - DTE Energy - Detroit Edison Company - 3,4,5**

Answer

Document Name

Comment

Please consider an approach where GIC monitor locations are determined on a regional basis in order to obtain the most value from each installation and insure that all areas are covered appropriately. An individual GO/TO may not have the information needed to properly place equipment. Also, providing monitoring equipment specifications would insure that manufacturers would design, and entities would install, capable monitors that will provide reliable data.

Likes 0

Dislikes 0

**Response.** The SDT will develop the GIC monitoring and magnetometer data collection requirements and determine the most appropriate location for those requirements. The SDT will work with the NERC GMD Task Force on the issue of equipment specifications

**Michael Shaw - Lower Colorado River Authority - 1,5,6, Group Name LCRA Compliance**

Answer

Document Name

Comment

Likes 0

Dislikes 0

**Response**



## Standards Authorization Request Form

When completed, email this form to:  
[sarcomm@nerc.com](mailto:sarcomm@nerc.com)

NERC welcomes suggestions to improve the reliability of the bulk power system through improved reliability standards. Please use this form to submit your request to propose a new or a revision to a NERC's Reliability Standard.

### Request to propose a new or a revision to a Reliability Standard

Title of Proposed Standard(s):	Modifications to Geomagnetic Disturbance Standards		
Date Submitted:	February 23, 2017		
SAR Requester Information			
Name:	Frank Koza		
Organization:	PJM Interconnection / Project 2013-03 SDT Chair		
Telephone:	610-666-4228	E-mail:	frank.koza@pjm.com
SAR Type (Check as many as applicable)			
<input checked="" type="checkbox"/> New Standard	<input type="checkbox"/> Withdrawal of existing Standard		
<input checked="" type="checkbox"/> Revision to existing Standard	<input type="checkbox"/> Urgent Action		

### SAR Information

Purpose (Describe what the standard action will achieve in support of Bulk Electric System reliability.):

The goal of this project is to address the Federal Energy Regulatory Commission (Commission) directives contained in Order No. 830 by modifying **TPL-007-1 - Transmission System Planned Performance for Geomagnetic Disturbance Events** and the benchmark GMD event used in GMD Vulnerability Assessments or by developing an equally efficient and effective alternative.

Industry Need (What is the industry problem this request is trying to solve?):

On September 22, 2016, the Commission issued Order No. 830 approving TPL-007-1. In the order, the Commission directed NERC to develop certain modifications to the Standard, including:

- Modify the benchmark GMD event definition used for GMD Vulnerability Assessments;
- Make related modifications to requirements pertaining to transformer thermal impact assessments;

## SAR Information

- Require collection of GMD-related data, which NERC should make available to the public; and
- Require deadlines for Corrective Action Plans (CAPs) and GMD mitigating actions.

The Commission established a deadline of 18 months from the effective date of Order No. 830 for completing the revisions, which is May 29, 2018.

Brief Description (Provide a paragraph that describes the scope of this standard action.)

The Standards Drafting Team (SDT) shall develop modifications to TPL-007-1 and the benchmark GMD event that address Commission directives from Order No. 830. The work will include development of Violation Risk Factors, Violation Severity Levels, and an Implementation Plan for the modified standards within the deadline established by the Commission in Order No. 830.

Detailed Description (Provide a description of the proposed project with sufficient details for the standard drafting team to execute the SAR. Also provide a justification for the development or revision of the standard, including an assessment of the reliability and market interface impacts of implementing or not implementing the standard action.)

The SDT shall address each of the Order No. 830 directives by developing modifications to requirements in TPL-007-1 and related material, or the SDT shall develop an equally efficient and effective alternative. To address concerns identified in Order No. 830, the Commission directed the following:

**Benchmark GMD Event (TPL-007-1 Attachment 1 and related requirements)**

- *[T]he Commission, as proposed in the NOPR, directs NERC to develop revisions to the benchmark GMD event definition so that the reference peak geoelectric field amplitude component is not based solely on spatially-averaged data. (P.44)*
- *Without prejudging how NERC proposes to address the Commission's directive, NERC's response to this directive should satisfy the NOPR's concern that reliance on spatially-averaged data alone does not address localized peaks that could potentially affect the reliable operation of the Bulk-Power System. (P.47)*

**Transformer Thermal Impact Assessment (TPL-007-1 Requirement R6)**

- *Consistent with our determination above regarding the reference peak geoelectric field amplitude value, the Commission directs NERC to revise Requirement R6 to require registered entities to apply spatially averaged and non-spatially averaged peak geoelectric field values, or some equally efficient and effective alternative, when conducting thermal impact assessments. (P.65)*

**Collection of GMD Data**

- *The Commission ... adopts the NOPR proposal in relevant part and directs NERC to develop revisions to Reliability Standard TPL-007-1 to require responsible entities to collect GIC monitoring and magnetometer data as necessary to enable model validation and situational awareness, including from any devices that must be added to meet this need. The NERC standard*

SAR Information

*drafting team should address the criteria for collecting GIC monitoring and magnetometer data... and provide registered entities with sufficient guidance in terms of defining the data that must be collected.... (P.88)*

- *Each responsible entity that is a transmission owner should be required to collect necessary GIC monitoring data. However, a transmission owner should be able to apply for an exemption from the GIC monitoring data collection requirement if it demonstrates that little or no value would be added to planning and operations. (P.91)*
- *NERC may also propose to incorporate the GIC monitoring and magnetometer data collection requirements in a different Reliability Standard....(P.91)*

**Deadlines for Corrective Action Plans and Mitigations (TPL-007-1 Requirement R7)**

- *The Commission directs NERC to modify Reliability Standard TPL-007-1 to include a deadline of one year from the completion of the GMD Vulnerability Assessments to complete the development of corrective action plans. (P.101)*
- *The Commission also directs NERC to modify Reliability Standard TPL-007-1 to include a two-year deadline after the development of the corrective action plan to complete the implementation of non-hardware mitigation and four-year deadline to complete hardware mitigation.... The Commission agrees that NERC should consider extensions of time on a case-by-case basis. (P.102)*

Reliability Functions

The Standard will Apply to the Following Functions (Check each one that applies.)

<input type="checkbox"/> Regional Reliability Organization	Conducts the regional activities related to planning and operations, and coordinates activities of Responsible Entities to secure the reliability of the Bulk Electric System within the region and adjacent regions.
<input type="checkbox"/> Reliability Coordinator	Responsible for the real-time operating reliability of its Reliability Coordinator Area in coordination with its neighboring Reliability Coordinator’s wide area view.
<input type="checkbox"/> Balancing Authority	Integrates resource plans ahead of time, and maintains load-interchange-resource balance within a Balancing Authority Area and supports Interconnection frequency in real time.
<input type="checkbox"/> Interchange Authority	Ensures communication of interchange transactions for reliability evaluation purposes and coordinates implementation of valid and balanced interchange schedules between Balancing Authority Areas.

Reliability Functions	
<input checked="" type="checkbox"/> Planning Coordinator	Assesses the longer-term reliability of its Planning Coordinator Area.
<input type="checkbox"/> Resource Planner	Develops a >one year plan for the resource adequacy of its specific loads within a Planning Coordinator area.
<input checked="" type="checkbox"/> Transmission Planner	Develops a >one year plan for the reliability of the interconnected Bulk Electric System within its portion of the Planning Coordinator area.
<input type="checkbox"/> Transmission Service Provider	Administers the transmission tariff and provides transmission services under applicable transmission service agreements (e.g., the pro forma tariff).
<input checked="" type="checkbox"/> Transmission Owner	Owns and maintains transmission facilities.
<input type="checkbox"/> Transmission Operator	Ensures the real-time operating reliability of the transmission assets within a Transmission Operator Area.
<input type="checkbox"/> Distribution Provider	Delivers electrical energy to the End-use customer.
<input checked="" type="checkbox"/> Generator Owner	Owns and maintains generation facilities.
<input type="checkbox"/> Generator Operator	Operates generation unit(s) to provide real and Reactive Power.
<input type="checkbox"/> Purchasing-Selling Entity	Purchases or sells energy, capacity, and necessary reliability-related services as required.
<input type="checkbox"/> Market Operator	Interface point for reliability functions with commercial functions.
<input type="checkbox"/> Load-Serving Entity	Secures energy and transmission service (and reliability-related services) to serve the End-use Customer.

Reliability and Market Interface Principles	
Applicable Reliability Principles (Check all that apply).	
<input checked="" type="checkbox"/>	1. Interconnected bulk power systems shall be planned and operated in a coordinated manner to perform reliably under normal and abnormal conditions as defined in the NERC Standards.
<input type="checkbox"/>	2. The frequency and voltage of interconnected bulk power systems shall be controlled within defined limits through the balancing of real and Reactive Power supply and demand.
<input checked="" type="checkbox"/>	3. Information necessary for the planning and operation of interconnected bulk power systems shall be made available to those entities responsible for planning and operating the systems reliably.
<input type="checkbox"/>	4. Plans for emergency operation and system restoration of interconnected bulk power systems shall be developed, coordinated, maintained and implemented.

Reliability and Market Interface Principles

<input type="checkbox"/>	5. Facilities for communication, monitoring and control shall be provided, used and maintained for the reliability of interconnected bulk power systems.
<input type="checkbox"/>	6. Personnel responsible for planning and operating interconnected bulk power systems shall be trained, qualified, and have the responsibility and authority to implement actions.
<input checked="" type="checkbox"/>	7. The security of the interconnected bulk power systems shall be assessed, monitored and maintained on a wide area basis.
<input type="checkbox"/>	8. Bulk power systems shall be protected from malicious physical or cyber attacks.
Does the proposed Standard comply with all of the following Market Interface Principles?	
	Enter (yes/no)
1. A reliability standard shall not give any market participant an unfair competitive advantage.	YES
2. A reliability standard shall neither mandate nor prohibit any specific market structure.	YES
3. A reliability standard shall not preclude market solutions to achieving compliance with that standard.	YES
4. A reliability standard shall not require the public disclosure of commercially sensitive information. All market participants shall have equal opportunity to access commercially non-sensitive information that is required for compliance with reliability standards.	YES

Related Standards

Standard No.	Explanation

Related SARs

SAR ID	Explanation

Regional Variances	
Region	Explanation
FRCC	
MRO	
NPCC	
RF	
SERC	
SPP RE	
Texas RE	
WECC	

## Standards Authorization Request Form

When completed, email this form to:  
[sarcomm@nerc.com](mailto:sarcomm@nerc.com)

NERC welcomes suggestions to improve the reliability of the bulk power system through improved reliability standards. Please use this form to submit your request to propose a new or a revision to a NERC's Reliability Standard.

### Request to propose a new or a revision to a Reliability Standard

Title of Proposed Standard(s):	Modifications to Geomagnetic Disturbance Standards		
Date Submitted:	<del>December-February 123, 2016</del> 2017		
SAR Requester Information			
Name:	Frank Koza		
Organization:	PJM Interconnection / Project 2013-03 SDT Chair		
Telephone:	610-666-4228	E-mail:	frank.koza@pjm.com
SAR Type (Check as many as applicable)			
<input checked="" type="checkbox"/> New Standard	<input type="checkbox"/> Withdrawal of existing Standard		
<input checked="" type="checkbox"/> Revision to existing Standard	<input type="checkbox"/> Urgent Action		

### SAR Information

Purpose (Describe what the standard action will achieve in support of Bulk Electric System reliability.):

The goal of this project is to address the Federal Energy Regulatory Commission (Commission) directives contained in Order No. 830 by modifying **TPL-007-1 - Transmission System Planned Performance for Geomagnetic Disturbance Events** and the benchmark GMD event used in GMD Vulnerability Assessments or by developing an equally efficient and effective alternative.

Industry Need (What is the industry problem this request is trying to solve?):

On September 22, 2016, the Commission issued Order No. 830 approving TPL-007-1. In the order, the Commission directed NERC to develop certain modifications to the Standard, including:

- Modify the benchmark GMD event definition used for GMD Vulnerability Assessments;
- Make related modifications to requirements pertaining to transformer thermal impact assessments;

## SAR Information

- Require collection of GMD-related data, ~~which and for~~ NERC ~~should~~ make ~~it available to the publicly available~~; and
- Require deadlines for Corrective Action Plans (CAPs) and GMD mitigating actions.

The Commission established a deadline of 18 months from the effective date of Order No. 830 for completing the revisions, which is May 29, 2018.

Brief Description (Provide a paragraph that describes the scope of this standard action.)

The Standards Drafting Team (SDT) shall develop modifications to TPL-007-1 and the benchmark GMD event that address Commission directives from Order No. 830. The work will include development of Violation Risk Factors, Violation Severity Levels, and an Implementation Plan for the modified standards within the deadline established by the Commission in Order No. 830.

Detailed Description (Provide a description of the proposed project with sufficient details for the standard drafting team to execute the SAR. Also provide a justification for the development or revision of the standard, including an assessment of the reliability and market interface impacts of implementing or not implementing the standard action.)

The SDT shall address each of the Order No. 830 directives by developing modifications to requirements in TPL-007-1 and related material, or the SDT shall develop an equally efficient and effective alternative. To address concerns identified in Order No. 830, the Commission directed the following:

**Benchmark GMD Event (TPL-007-1 Attachment 1 and related requirements)**

- *[T]he Commission, as proposed in the NOPR, directs NERC to develop revisions to the benchmark GMD event definition so that the reference peak geoelectric field amplitude component is not based solely on spatially-averaged data. (P.44)*
- *Without prejudging how NERC proposes to address the Commission's directive, NERC's response to this directive should satisfy the NOPR's concern that reliance on spatially-averaged data alone does not address localized peaks that could potentially affect the reliable operation of the Bulk-Power System. (P.47)*

**Transformer Thermal Impact Assessment (TPL-007-1 Requirement R6)**

- *Consistent with our determination above regarding the reference peak geoelectric field amplitude value, the Commission directs NERC to revise Requirement R6 to require registered entities to apply spatially averaged and non-spatially averaged peak geoelectric field values, or some equally efficient and effective alternative, when conducting thermal impact assessments. (P.65)*

**Collection of GMD Data**

- *The Commission ... adopts the NOPR proposal in relevant part and directs NERC to develop revisions to Reliability Standard TPL-007-1 to require responsible entities to collect GIC monitoring and magnetometer data as necessary to enable model validation and situational awareness, including from any devices that must be added to meet this need. The NERC standard*



SAR Information

*drafting team should address the criteria for collecting GIC monitoring and magnetometer data... and provide registered entities with sufficient guidance in terms of defining the data that must be collected.... (P.88)*

- *Each responsible entity that is a transmission owner should be required to collect necessary GIC monitoring data. However, a transmission owner should be able to apply for an exemption from the GIC monitoring data collection requirement if it demonstrates that little or no value would be added to planning and operations. (P.91)*
- *NERC may also propose to incorporate the GIC monitoring and magnetometer data collection requirements in a different Reliability Standard....(P.91)*

**Deadlines for Corrective Action Plans and Mitigations (TPL-007-1 Requirement R7)**

- *The Commission directs NERC to modify Reliability Standard TPL-007-1 to include a deadline of one year from the completion of the GMD Vulnerability Assessments to complete the development of corrective action plans. (P.101)*
- *The Commission also directs NERC to modify Reliability Standard TPL-007-1 to include a two-year deadline after the development of the corrective action plan to complete the implementation of non-hardware mitigation and four-year deadline to complete hardware mitigation.... The Commission agrees that NERC should consider extensions of time on a case-by-case basis. (P.102)*

Reliability Functions

The Standard will Apply to the Following Functions (Check each one that applies.)

<input type="checkbox"/> Regional Reliability Organization	Conducts the regional activities related to planning and operations, and coordinates activities of Responsible Entities to secure the reliability of the Bulk Electric System within the region and adjacent regions.
<input type="checkbox"/> Reliability Coordinator	Responsible for the real-time operating reliability of its Reliability Coordinator Area in coordination with its neighboring Reliability Coordinator’s wide area view.
<input type="checkbox"/> Balancing Authority	Integrates resource plans ahead of time, and maintains load-interchange-resource balance within a Balancing Authority Area and supports Interconnection frequency in real time.
<input type="checkbox"/> Interchange Authority	Ensures communication of interchange transactions for reliability evaluation purposes and coordinates implementation of valid and balanced interchange schedules between Balancing Authority Areas.

Reliability Functions	
<input checked="" type="checkbox"/> Planning Coordinator	Assesses the longer-term reliability of its Planning Coordinator Area.
<input type="checkbox"/> Resource Planner	Develops a >one year plan for the resource adequacy of its specific loads within a Planning Coordinator area.
<input checked="" type="checkbox"/> Transmission Planner	Develops a >one year plan for the reliability of the interconnected Bulk Electric System within its portion of the Planning Coordinator area.
<input type="checkbox"/> Transmission Service Provider	Administers the transmission tariff and provides transmission services under applicable transmission service agreements (e.g., the pro forma tariff).
<input checked="" type="checkbox"/> Transmission Owner	Owns and maintains transmission facilities.
<input type="checkbox"/> Transmission Operator	Ensures the real-time operating reliability of the transmission assets within a Transmission Operator Area.
<input type="checkbox"/> Distribution Provider	Delivers electrical energy to the End-use customer.
<input checked="" type="checkbox"/> Generator Owner	Owns and maintains generation facilities.
<input type="checkbox"/> Generator Operator	Operates generation unit(s) to provide real and Reactive Power.
<input type="checkbox"/> Purchasing-Selling Entity	Purchases or sells energy, capacity, and necessary reliability-related services as required.
<input type="checkbox"/> Market Operator	Interface point for reliability functions with commercial functions.
<input type="checkbox"/> Load-Serving Entity	Secures energy and transmission service (and reliability-related services) to serve the End-use Customer.

Reliability and Market Interface Principles	
Applicable Reliability Principles (Check all that apply).	
<input checked="" type="checkbox"/>	1. Interconnected bulk power systems shall be planned and operated in a coordinated manner to perform reliably under normal and abnormal conditions as defined in the NERC Standards.
<input type="checkbox"/>	2. The frequency and voltage of interconnected bulk power systems shall be controlled within defined limits through the balancing of real and Reactive Power supply and demand.
<input checked="" type="checkbox"/>	3. Information necessary for the planning and operation of interconnected bulk power systems shall be made available to those entities responsible for planning and operating the systems reliably.
<input type="checkbox"/>	4. Plans for emergency operation and system restoration of interconnected bulk power systems shall be developed, coordinated, maintained and implemented.

Reliability and Market Interface Principles

<input type="checkbox"/>	5. Facilities for communication, monitoring and control shall be provided, used and maintained for the reliability of interconnected bulk power systems.
<input type="checkbox"/>	6. Personnel responsible for planning and operating interconnected bulk power systems shall be trained, qualified, and have the responsibility and authority to implement actions.
<input checked="" type="checkbox"/>	7. The security of the interconnected bulk power systems shall be assessed, monitored and maintained on a wide area basis.
<input type="checkbox"/>	8. Bulk power systems shall be protected from malicious physical or cyber attacks.

Does the proposed Standard comply with all of the following Market Interface Principles?	Enter (yes/no)
1. A reliability standard shall not give any market participant an unfair competitive advantage.	YES
2. A reliability standard shall neither mandate nor prohibit any specific market structure.	YES
3. A reliability standard shall not preclude market solutions to achieving compliance with that standard.	YES
4. A reliability standard shall not require the public disclosure of commercially sensitive information. All market participants shall have equal opportunity to access commercially non-sensitive information that is required for compliance with reliability standards.	YES

Related Standards

Standard No.	Explanation

Related SARs

SAR ID	Explanation

Regional Variances	
Region	Explanation
FRCC	
MRO	
NPCC	
RF	
SERC	
SPP RE	
Texas RE	
WECC	

## Standard Development Timeline

This section is maintained by the drafting team during the development of the standard and will be removed when the standard is adopted by the NERC Board of Trustees (Board).

### Description of Current Draft

Completed Actions	Date
Standards Committee approved Standard Authorization Request (SAR) for posting	December 14, 2016
SAR posted for comment	December 16, 2016 – January 20, 2017

Anticipated Actions	Date
45-day formal comment period with ballot	June 2017
45-day formal comment period with additional ballot	September 2017
10-day final ballot	TBD
Board adoption	February 2018

## **New or Modified Term(s) Used in NERC Reliability Standards**

This section includes all new or modified terms used in the proposed standard that will be included in the *Glossary of Terms Used in NERC Reliability Standards* upon applicable regulatory approval. Terms used in the proposed standard that are already defined and are not being modified can be found in the *Glossary of Terms Used in NERC Reliability Standards*. The new or revised terms listed below will be presented for approval with the proposed standard. Upon Board adoption, this section will be removed.

**Term(s):**

None

Upon Board adoption, the rationale boxes will be moved to the Supplemental Material Section.

## A. Introduction

1. **Title:** Transmission System Planned Performance for Geomagnetic Disturbance Events
2. **Number:** TPL-007-2
3. **Purpose:** Establish requirements for Transmission system planned performance during geomagnetic disturbance (GMD) events.
4. **Applicability:**
  - 4.1. **Functional Entities:**
    - 4.1.1. Planning Coordinator with a planning area that includes a Facility or Facilities specified in 4.2;
    - 4.1.2. Transmission Planner with a planning area that includes a Facility or Facilities specified in 4.2;
    - 4.1.3. Transmission Owner who owns a Facility or Facilities specified in 4.2;
    - 4.1.4. Generator Owner who owns a Facility or Facilities specified in 4.2.
  - 4.2. **Facilities:**
    - 4.2.1. Facilities that include power transformer(s) with a high side, wye-grounded winding with terminal voltage greater than 200 kV.
5. **Effective Date:** See Implementation Plan for TPL-007-1
6. **Background:**

During a GMD event, geomagnetically-induced currents (GIC) may cause transformer hot-spot heating or damage, loss of Reactive Power sources, increased Reactive Power demand, and Misoperation(s), the combination of which may result in voltage collapse and blackout.

## B. Requirements and Measures

- R1.** Each Planning Coordinator, in conjunction with its Transmission Planner(s), shall identify the individual and joint responsibilities of the Planning Coordinator and Transmission Planner(s) in the Planning Coordinator's planning area for maintaining models, performing the study or studies needed to complete benchmark and supplemental GMD Vulnerability Assessments, and implementing process(es) to obtain GMD measurement data as specified in this standard. *[Violation Risk Factor: Lower] [Time Horizon: Long-term Planning]*
- M1.** Each Planning Coordinator, in conjunction with its Transmission Planners, shall provide documentation on roles and responsibilities, such as meeting minutes, agreements,

copies of procedures or protocols in effect between entities or between departments of a vertically integrated system, or email correspondence that identifies an agreement has been reached on individual and joint responsibilities for maintaining models, performing the study or studies needed to complete benchmark and supplemental GMD Vulnerability Assessments, and implementing process(es) to obtain GMD measurement data in accordance with Requirement R1.

- R2.** Each responsible entity, as determined in Requirement R1, shall maintain System models and GIC System models of the responsible entity's planning area for performing the study or studies needed to complete benchmark and supplemental GMD Vulnerability Assessments. *[Violation Risk Factor: High] [Time Horizon: Long-term Planning]*
- M2.** Each responsible entity, as determined in Requirement R1, shall have evidence in either electronic or hard copy format that it is maintaining System models and GIC System models of the responsible entity's planning area for performing the study or studies needed to complete benchmark and supplemental GMD Vulnerability Assessments.
- R3.** Each responsible entity, as determined in Requirement R1, shall have criteria for acceptable System steady state voltage performance for its System during the GMD events described in Attachment 1. *[Violation Risk Factor: Medium] [Time Horizon: Long-term Planning]*
- M3.** Each responsible entity, as determined in Requirement R1, shall have evidence, such as electronic or hard copies of the criteria for acceptable System steady state voltage performance for its System in accordance with Requirement R3.

**Benchmark GMD Vulnerability Assessment(s)**

- R4.** Each responsible entity, as determined in Requirement R1, shall complete a benchmark GMD Vulnerability Assessment of the Near-Term Transmission Planning Horizon at least once every 60 calendar months. This benchmark GMD Vulnerability Assessment shall use a study or studies based on models identified in Requirement R2, document assumptions, and document summarized results of the steady state analysis. *[Violation Risk Factor: High] [Time Horizon: Long-term Planning]*
  - 4.1.** The study or studies shall include the following conditions:
    - 4.1.1.** System On-Peak Load for at least one year within the Near-Term Transmission Planning Horizon; and
    - 4.1.2.** System Off-Peak Load for at least one year within the Near-Term Transmission Planning Horizon.
  - 4.2.** The study or studies shall be conducted based on the benchmark GMD event described in Attachment 1 to determine whether the System meets the



performance requirements for the steady state planning benchmark GMD event contained in Table 1.

**4.3.** The benchmark GMD Vulnerability Assessment shall be provided: (i) to the responsible entity's Reliability Coordinator, adjacent Planning Coordinators, and adjacent Transmission Planners within 90 calendar days of completion, and (ii) to any functional entity that submits a written request and has a reliability-related need within 90 calendar days of receipt of such request or within 90 calendar days of completion of the benchmark GMD Vulnerability Assessment, whichever is later.

**4.3.1.** If a recipient of the benchmark GMD Vulnerability Assessment provides documented comments on the results, the responsible entity shall provide a documented response to that recipient within 90 calendar days of receipt of those comments.

**M4.** Each responsible entity, as determined in Requirement R1, shall have dated evidence such as electronic or hard copies of its benchmark GMD Vulnerability Assessment meeting all of the requirements in Requirement R4. Each responsible entity, as determined in Requirement R1, shall also provide evidence, such as email records, web postings with an electronic notice of posting, or postal receipts showing recipient and date, that it has distributed its benchmark GMD Vulnerability Assessment: (i) to the responsible entity's Reliability Coordinator, adjacent Planning Coordinators, and adjacent Transmission Planners within 90 calendar days of completion, and (ii) to any functional entity that submits a written request and has a reliability-related need within 90 calendar days of receipt of such request or within 90 calendar days of completion of the benchmark GMD Vulnerability Assessment, whichever is later, as specified in Requirement R4. Each responsible entity, as determined in Requirement R1, shall also provide evidence, such as email notices or postal receipts showing recipient and date, that it has provided a documented response to comments received on its benchmark GMD Vulnerability Assessment within 90 calendar days of receipt of those comments in accordance with Requirement R4.

**R5.** Each responsible entity, as determined in Requirement R1, shall provide GIC flow information to be used for the benchmark thermal impact assessment of transformers specified in Requirement R6 to each Transmission Owner and Generator Owner that owns an applicable Bulk Electric System (BES) power transformer in the planning area. The GIC flow information shall include: *[Violation Risk Factor: Medium] [Time Horizon: Long-term Planning]*

**5.1.** The maximum effective GIC value for the worst case geoelectric field orientation for the benchmark GMD event described in Attachment 1. This value shall be provided to the Transmission Owner or Generator Owner that owns each applicable BES power transformer in the planning area.

**5.2.** The effective GIC time series, GIC(t), calculated using the benchmark GMD event described in Attachment 1 in response to a written request from the

Transmission Owner or Generator Owner that owns an applicable BES power transformer in the planning area. GIC(t) shall be provided within 90 calendar days of receipt of the written request and after determination of the maximum effective GIC value in Part 5.1.

- M5.** Each responsible entity, as determined in Requirement R1, shall provide evidence, such as email records, web postings with an electronic notice of posting, or postal receipts showing recipient and date, that it has provided the maximum effective benchmark GIC value to the Transmission Owner and Generator Owner that owns each applicable BES power transformer in the planning area as specified in Requirement R5, Part 5.1. Each responsible entity, as determined in Requirement R1, shall also provide evidence, such as email records, web postings with an electronic notice of posting, or postal receipts showing recipient and date, that it has provided GIC(t) in response to a written request from the Transmission Owner or Generator Owner that owns an applicable BES power transformer in the planning area.
- R6.** Each Transmission Owner and Generator Owner shall conduct a benchmark thermal impact assessment for its solely and jointly owned applicable BES power transformers where the maximum effective GIC value provided in Requirement R5, Part 5.1, is 75 A per phase or greater. The benchmark thermal impact assessment shall: *[Violation Risk Factor: Medium] [Time Horizon: Long-term Planning]*
- 6.1.** Be based on the effective GIC flow information provided in Requirement R5;
  - 6.2.** Document assumptions used in the analysis;
  - 6.3.** Describe suggested actions and supporting analysis to mitigate the impact of GICs, if any; and
  - 6.4.** Be performed and provided to the responsible entities, as determined in Requirement R1, within 24 calendar months of receiving GIC flow information specified in Requirement R5, Part 5.1.
- M6.** Each Transmission Owner and Generator Owner shall have evidence such as electronic or hard copies of its benchmark thermal impact assessment for all of its solely and jointly owned applicable BES power transformers where the maximum effective GIC value provided in Requirement R5, Part 5.1, is 75 A per phase or greater, and shall have evidence such as email records, web postings with an electronic notice of posting, or postal receipts showing recipient and date, that it has provided its thermal impact assessment to the responsible entities as specified in Requirement R6.

**Rationale for Requirement R7:** The proposed requirement addresses directives in Order No. 830 for establishing Corrective Action Plan (CAP) deadlines associated with GMD Vulnerability Assessments. In Order No. 830, FERC directed revisions to TPL-007 such that CAPs are developed within one year from the completion of GMD Vulnerability Assessments (P. 101). Furthermore, FERC directed establishment of implementation deadlines after the completion of the CAP as follows (P. 102):

- Two years for non-hardware mitigation; and
- Four years for hardware mitigation.

The objective of Part 7.4 is to provide awareness to potentially impacted entities when implementation of planned mitigation is not achievable within the deadlines established in Part 7.3.

**R7.** Each responsible entity, as determined in Requirement R1, that concludes through the benchmark GMD Vulnerability Assessment conducted in Requirement R4 that their System does not meet the performance requirements for the steady state planning benchmark GMD event contained in Table 1 shall develop a Corrective Action Plan (CAP) addressing how the performance requirements will be met. The CAP shall: *[Violation Risk Factor: High] [Time Horizon: Long-term Planning]*

**7.1.** List System deficiencies and the associated actions needed to achieve required System performance. Examples of such actions include:

- Installation, modification, retirement, or removal of Transmission and generation Facilities and any associated equipment.
- Installation, modification, or removal of Protection Systems or Remedial Action Schemes.
- Use of Operating Procedures, specifying how long they will be needed as part of the CAP.
- Use of Demand-Side Management, new technologies, or other initiatives.

**7.2.** Be developed within one year of completion of the benchmark GMD Vulnerability Assessment.

**7.3.** Include a timetable, subject to revision by the responsible entity in Part 7.4, for implementing the selected actions from Part 7.1. The timetable shall:

**7.3.1.** Specify implementation of non-hardware mitigation, if any, within two years of development of the CAP; and

**7.3.2.** Specify implementation of hardware mitigation, if any, within four years of development of the CAP.

**7.4.** Be revised if situations beyond the control of the responsible entity determined in Requirement R1 prevent implementation of the CAP within the timetable for implementation provided in Part 7.3. The revised CAP shall document the following, and be updated at least once every 12 calendar months until implemented:

**7.4.1.** Circumstances causing the delay for fully or partially implementing the selected actions in Part 7.1;



**Supplemental GMD Vulnerability Assessment(s)**

**Rationale for Requirements R8 - R10:** The proposed requirements address directives in Order No. 830 for revising the benchmark GMD event used in GMD Vulnerability Assessments (P.44, P47-49). The requirements add a supplemental GMD Vulnerability Assessment based on the supplemental GMD event that accounts for localized peak geoelectric fields.

- R8.** Each responsible entity, as determined in Requirement R1, shall complete a supplemental GMD Vulnerability Assessment of the Near-Term Transmission Planning Horizon at least once every 60 calendar months. This supplemental GMD Vulnerability Assessment shall use a study or studies based on models identified in Requirement R2, document assumptions, and document summarized results of the steady state analysis. [*Violation Risk Factor: High*] [*Time Horizon: Long-term Planning*]
- 8.1.** The study or studies shall include the following conditions:
- 8.1.1.** System On-Peak Load for at least one year within the Near-Term Transmission Planning Horizon; and
  - 8.1.2.** System Off-Peak Load for at least one year within the Near-Term Transmission Planning Horizon.
- 8.2.** The study or studies shall be conducted based on the supplemental GMD event described in Attachment 1 to determine whether the System meets the performance requirements for the steady state planning supplemental GMD event contained in Table 1.
- 8.3.** If the analysis concludes there is Cascading caused by the supplemental GMD event described in Attachment 1, an evaluation of possible actions designed to reduce the likelihood or mitigate the consequences and adverse impacts of the event(s) shall be conducted.
- 8.4.** The supplemental GMD Vulnerability Assessment shall be provided: (i) to the responsible entity's Reliability Coordinator, adjacent Planning Coordinators, adjacent Transmission Planners within 90 calendar days of completion, and (ii) to any functional entity that submits a written request and has a reliability-related need within 90 calendar days of receipt of such request or within 90 calendar days of completion of the supplemental GMD Vulnerability Assessment, whichever is later.
- 8.4.1.** If a recipient of the supplemental GMD Vulnerability Assessment provides documented comments on the results, the responsible entity shall provide a documented response to that recipient within 90 calendar days of receipt of those comments.
- M8.** Each responsible entity, as determined in Requirement R1, shall have dated evidence such as electronic or hard copies of its supplemental GMD Vulnerability Assessment

meeting all of the requirements in Requirement R8. Each responsible entity, as determined in Requirement R1, shall also provide evidence, such as email records, web postings with an electronic notice of posting, or postal receipts showing recipient and date, that it has distributed its supplemental GMD Vulnerability: (i) to the responsible entity's Reliability Coordinator, adjacent Planning Coordinators, adjacent Transmission Planners within 90 calendar days of completion, and (ii) to any functional entity that submits a written request and has a reliability-related need within 90 calendar days of receipt of such request or within 90 calendar days of completion of the supplemental GMD Vulnerability Assessment, whichever is later, as specified in Requirement R8. Each responsible entity, as determined in Requirement R1, shall also provide evidence, such as email notices or postal receipts showing recipient and date, that it has provided a documented response to comments received on its supplemental GMD Vulnerability Assessment within 90 calendar days of receipt of those comments in accordance with Requirement R8.

- R9.** Each responsible entity, as determined in Requirement R1, shall provide GIC flow information to be used for the supplemental thermal impact assessment of transformers specified in Requirement R10 to each Transmission Owner and Generator Owner that owns an applicable Bulk Electric System (BES) power transformer in the planning area. The GIC flow information shall include: *[Violation Risk Factor: Medium] [Time Horizon: Long-term Planning]*
- 9.1.** The maximum effective GIC value for the worst case geoelectric field orientation for the supplemental GMD event described in Attachment 1. This value shall be provided to the Transmission Owner or Generator Owner that owns each applicable BES power transformer in the planning area.
- 9.2.** The effective GIC time series, GIC(t), calculated using the supplemental GMD event described in Attachment 1 in response to a written request from the Transmission Owner or Generator Owner that owns an applicable BES power transformer in the planning area. GIC(t) shall be provided within 90 calendar days of receipt of the written request and after determination of the maximum effective GIC value in Part 9.1.
- M9.** Each responsible entity, as determined in Requirement R1, shall provide evidence, such as email records, web postings with an electronic notice of posting, or postal receipts showing recipient and date, that it has provided the maximum effective supplemental GIC value to the Transmission Owner and Generator Owner that owns each applicable BES power transformer in the planning area as specified in Requirement R9, Part 9.1. Each responsible entity, as determined in Requirement R1, shall also provide evidence, such as email records, web postings with an electronic notice of posting, or postal receipts showing recipient and date, that it has provided GIC(t) in response to a written request from the Transmission Owner or Generator Owner that owns an applicable BES power transformer in the planning area.
- R10.** Each Transmission Owner and Generator Owner shall conduct a supplemental thermal impact assessment for its solely and jointly owned applicable BES power

transformers where the maximum effective GIC value provided in Requirement R9, Part 9.1, is 85 A per phase or greater. The supplemental thermal impact assessment shall: [*Violation Risk Factor: Medium*] [*Time Horizon: Long-term Planning*]

**10.1.** Be based on the effective GIC flow information provided in Requirement R9;

**10.2.** Document assumptions used in the analysis;

**10.3.** Describe suggested actions and supporting analysis to mitigate the impact of GICs, if any; and

**10.4.** Be performed and provided to the responsible entities, as determined in Requirement R1, within 24 calendar months of receiving GIC flow information specified in Requirement R9, Part 9.1.

**M10.** Each Transmission Owner and Generator Owner shall have evidence such as electronic or hard copies of its supplemental thermal impact assessment for all of its solely and jointly owned applicable BES power transformers where the maximum effective GIC value provided in Requirement R9, Part 9.1, is 85 A per phase or greater, and shall have evidence such as email records, web postings with an electronic notice of posting, or postal receipts showing recipient and date, that it has provided its supplemental thermal impact assessment to the responsible entities as specified in Requirement R10.

### GMD Measurement Data Processes

**Rationale for Requirements R11 and R12:** The proposed requirements address directives in Order No. 830 for requiring responsible entities to collect GIC monitoring and magnetometer data as necessary to enable model validation and situational awareness (P. 88; P. 90-92). See the Guidelines and Technical Basis section of this standard for technical information.

The objective of Requirement R11 is for entities to obtain GIC data for the Planning Coordinator's planning area or other part of the system included in the Planning Coordinator's GIC System model to inform GMD Vulnerability Assessments. Technical considerations for GIC monitoring are contained in Chapter 6 of the *2012 Special Reliability Assessment Interim Report: Effects of Geomagnetic Disturbances on the Bulk-Power System* (NERC 2012 GMD Report). GIC monitoring is generally performed by Hall effect transducers that are attached to the neutral of the transformer and measure dc current flowing through the neutral.

The objective of Requirement R12 is for entities to obtain geomagnetic field data for the Planning Coordinator's planning area to inform GMD Vulnerability Assessments. Magnetometers provide geomagnetic field data by measuring changes in the earth's magnetic field. Sources of geomagnetic field data include:

- Observatories such as those operated by U.S. Geological Survey, Natural Resources Canada, research organizations, or university research facilities.
- Installed magnetometers

- Commercial or third-party sources of geomagnetic field data

Geomagnetic field data for a Planning Coordinator’s planning area is obtained from one or more of the above data sources located in the Planning Coordinator’s planning area, or by obtaining a geomagnetic field data product for the Planning Coordinator’s planning area from a government or research organization. The geomagnetic field data product does not need to be derived from a magnetometer or observatory within the Planning Coordinator’s planning area.

- R11.** Each responsible entity, as determined in Requirement R1, shall implement a process to obtain GIC monitor data from at least one GIC monitor located in the Planning Coordinator's planning area or other part of the system included in the Planning Coordinator's GIC System model. *[Violation Risk Factor: Lower] [Time Horizon: Long-term Planning]*
- M11.** Each responsible entity, as determined in Requirement R1, shall have evidence such as electronic or hard copies of its GIC monitor location(s) and documentation of its process to obtain GIC monitor data in accordance with Requirement R11.
- R12.** Each responsible entity, as determined in Requirement R1, shall implement a process to obtain geomagnetic field data for its Planning Coordinator’s planning area. *[Violation Risk Factor: Lower] [Time Horizon: Long-term Planning]*
- M12.** Each responsible entity, as determined in Requirement R1, shall have evidence such as electronic or hard copies of its process to obtain geomagnetic field data for its Planning Coordinator’s planning area in accordance with Requirement R12.

## C. Compliance

### 1. Compliance Monitoring Process

- 1.1. Compliance Enforcement Authority:** “Compliance Enforcement Authority” means NERC or the Regional Entity, or any entity as otherwise designated by an Applicable Governmental Authority, in their respective roles of monitoring and/or enforcing compliance with mandatory and enforceable Reliability Standards in their respective jurisdictions.
- 1.2. Evidence Retention:** The following evidence retention period(s) identify the period of time an entity is required to retain specific evidence to demonstrate compliance. For instances where the evidence retention period specified below is shorter than the time since the last audit, the Compliance Enforcement Authority may ask an entity to provide other evidence to show that it was compliant for the full-time period since the last audit.



The applicable entity shall keep data or evidence to show compliance as identified below unless directed by its Compliance Enforcement Authority to retain specific evidence for a longer period of time as part of an investigation.

- For Requirements R1, R2, R3, R5, R6, R9, and R10, each responsible entity shall retain documentation as evidence for five years.
- For Requirements R4 and R8, each responsible entity shall retain documentation of the current GMD Vulnerability Assessment and the preceding GMD Vulnerability Assessment.
- For Requirement R7, each responsible entity shall retain documentation as evidence for five years or until all actions in the Corrective Action Plan are completed, whichever is later.
- For Requirements R11 and R12, each responsible entity shall retain documentation as evidence for three years.

**1.3. Compliance Monitoring and Enforcement Program:** As defined in the NERC Rules of Procedure, “Compliance Monitoring and Enforcement Program” refers to the identification of the processes that will be used to evaluate data or information for the purpose of assessing performance or outcomes with the associated Reliability Standard.

Table 1 – Steady State Planning GMD Event				
<p><b>Steady State:</b></p> <ul style="list-style-type: none"> <li>a. Voltage collapse, Cascading and uncontrolled islanding shall not occur.</li> <li>b. Generation loss is acceptable as a consequence of the steady state planning GMD events.</li> <li>c. Planned System adjustments such as Transmission configuration changes and re-dispatch of generation are allowed if such adjustments are executable within the time duration applicable to the Facility Ratings.</li> </ul>				
Category	Initial Condition	Event	Interruption of Firm Transmission Service Allowed	Load Loss Allowed
<b>Benchmark GMD Event - GMD Event with Outages</b>	1. System as may be postured in response to space weather information <sup>1</sup> , and then 2. GMD event <sup>2</sup>	Reactive Power compensation devices and other Transmission Facilities removed as a result of Protection System operation or Misoperation due to harmonics during the GMD event	Yes <sup>3</sup>	Yes <sup>3</sup>
<b>Supplemental GMD Event - GMD Event with Outages</b>	1. System as may be postured in response to space weather information <sup>1</sup> , and then 2. GMD event <sup>2</sup>	Reactive Power compensation devices and other Transmission Facilities removed as a result of Protection System operation or Misoperation due to harmonics during the GMD event	Yes	Yes
Table 1 – Steady State Performance Footnotes				
<ol style="list-style-type: none"> <li>1. The System condition for GMD planning may include adjustments to posture the System that are executable in response to space weather information.</li> <li>2. The GMD conditions for the benchmark and supplemental planning events are described in Attachment 1.</li> <li>3. Load loss as a result of manual or automatic Load shedding (e.g., UVLS) and/or curtailment of Firm Transmission Service may be used to meet BES performance requirements during studied GMD conditions. The likelihood and magnitude of Load loss or curtailment of Firm Transmission Service should be minimized.</li> </ol>				

### Violation Severity Levels

R #	Violation Severity Levels			
	Lower VSL	Moderate VSL	High VSL	Severe VSL
<b>R1.</b>	N/A	N/A	N/A	The Planning Coordinator, in conjunction with its Transmission Planner(s), failed to determine and identify individual or joint responsibilities of the Planning Coordinator and Transmission Planner(s) in the Planning Coordinator’s planning area for maintaining models, performing the study or studies needed to complete benchmark and supplemental GMD Vulnerability Assessments, and implementing process(es) to obtain GMD measurement data as specified in this standard.
<b>R2.</b>	N/A	N/A	The responsible entity did not maintain either System models or GIC System models of the responsible entity’s planning area for performing the study or	The responsible entity did not maintain both System models and GIC System models of the responsible entity’s planning area for performing the study or

			studies needed to complete benchmark and supplemental GMD Vulnerability Assessments.	studies needed to complete benchmark and supplemental GMD Vulnerability Assessments.
<b>R3.</b>	N/A	N/A	N/A	The responsible entity did not have criteria for acceptable System steady state voltage performance for its System during the GMD events described in Attachment 1 as required.
<b>R4.</b>	The responsible entity completed a benchmark GMD Vulnerability Assessment, but it was more than 60 calendar months and less than or equal to 64 calendar months since the last benchmark GMD Vulnerability Assessment.	The responsible entity's completed benchmark GMD Vulnerability Assessment failed to satisfy one of elements listed in Requirement R4, Parts 4.1 through 4.3; OR The responsible entity completed a benchmark GMD Vulnerability Assessment, but it was more than 64 calendar months and less than or equal to 68 calendar months since the last benchmark GMD Vulnerability Assessment.	The responsible entity's completed benchmark GMD Vulnerability Assessment failed to satisfy two of the elements listed in Requirement R4, Parts 4.1 through 4.3; OR The responsible entity completed a benchmark GMD Vulnerability Assessment, but it was more than 68 calendar months and less than or equal to 72 calendar months since the last benchmark GMD Vulnerability Assessment.	The responsible entity's completed benchmark GMD Vulnerability Assessment failed to satisfy three of the elements listed in Requirement R4, Parts 4.1 through 4.3; OR The responsible entity completed a benchmark GMD Vulnerability Assessment, but it was more than 72 calendar months since the last benchmark GMD Vulnerability Assessment; OR

				The responsible entity does not have a completed benchmark GMD Vulnerability Assessment.
<b>R5.</b>	The responsible entity provided the effective GIC time series, GIC(t), in response to written request, but did so more than 90 calendar days and less than or equal to 100 calendar days after receipt of a written request.	The responsible entity provided the effective GIC time series, GIC(t), in response to written request, but did so more than 100 calendar days and less than or equal to 110 calendar days after receipt of a written request.	The responsible entity provided the effective GIC time series, GIC(t), in response to written request, but did so more than 110 calendar days after receipt of a written request.	The responsible entity did not provide the maximum effective GIC value to the Transmission Owner and Generator Owner that owns each applicable BES power transformer in the planning area; OR The responsible entity did not provide the effective GIC time series, GIC(t), upon written request.
<b>R6.</b>	The responsible entity failed to conduct a benchmark thermal impact assessment for 5% or less or one of its solely owned and jointly owned applicable BES power transformers (whichever is greater) where the maximum effective GIC value provided in Requirement R5, Part 5.1, is 75 A or greater per phase;	The responsible entity failed to conduct a benchmark thermal impact assessment for more than 5% up to (and including) 10% or two of its solely owned and jointly owned applicable BES power transformers (whichever is greater) where the maximum effective GIC value provided in Requirement R5,	The responsible entity failed to conduct a benchmark thermal impact assessment for more than 10% up to (and including) 15% or three of its solely owned and jointly owned applicable BES power transformers (whichever is greater) where the maximum effective GIC value provided in	The responsible entity failed to conduct a benchmark thermal impact assessment for more than 15% or more than three of its solely owned and jointly owned applicable BES power transformers (whichever is greater) where the maximum effective GIC value provided in Requirement R5,

	<p>OR</p> <p>The responsible entity conducted a benchmark thermal impact assessment for its solely owned and jointly owned applicable BES power transformers where the maximum effective GIC value provided in Requirement R5, Part 5.1, is 75 A or greater per phase but did so more than 24 calendar months and less than or equal to 26 calendar months of receiving GIC flow information specified in Requirement R5, Part 5.1.</p>	<p>Part 5.1, is 75 A or greater per phase;</p> <p>OR</p> <p>The responsible entity conducted a benchmark thermal impact assessment for its solely owned and jointly owned applicable BES power transformers where the maximum effective GIC value provided in Requirement R5, Part 5.1, is 75 A or greater per phase but did so more than 26 calendar months and less than or equal to 28 calendar months of receiving GIC flow information specified in Requirement R5, Part 5.1;</p> <p>OR</p> <p>The responsible entity failed to include one of the required elements as listed in Requirement R6, Parts 6.1 through 6.3.</p>	<p>Requirement R5, Part 5.1, is 75 A or greater per phase;</p> <p>OR</p> <p>The responsible entity conducted a benchmark thermal impact assessment for its solely owned and jointly owned applicable BES power transformers where the maximum effective GIC value provided in Requirement R5, Part 5.1, is 75 A or greater per phase but did so more than 28 calendar months and less than or equal to 30 calendar months of receiving GIC flow information specified in Requirement R5, Part 5.1;</p> <p>OR</p> <p>The responsible entity failed to include two of the required elements as listed in Requirement R6, Parts 6.1 through 6.3.</p>	<p>Part 5.1, is 75 A or greater per phase;</p> <p>OR</p> <p>The responsible entity conducted a benchmark thermal impact assessment for its solely owned and jointly owned applicable BES power transformers where the maximum effective GIC value provided in Requirement R5, Part 5.1, is 75 A or greater per phase but did so more than 30 calendar months of receiving GIC flow information specified in Requirement R5, Part 5.1;</p> <p>OR</p> <p>The responsible entity failed to include three of the required elements as listed in Requirement R6, Parts 6.1 through 6.3.</p>
<b>R7.</b>	<p>The responsible entity's Corrective Action Plan failed to comply with one of the elements in Requirement R7, Parts 7.1 through 7.5.</p>	<p>The responsible entity's Corrective Action Plan failed to comply with two of the elements in Requirement R7, Parts 7.1 through 7.5.</p>	<p>The responsible entity's Corrective Action Plan failed to comply with three of the elements in Requirement R7, Parts 7.1 through 7.5.</p>	<p>The responsible entity's Corrective Action Plan failed to comply with four or more of the elements in</p>

				<p>Requirement R7, Parts 7.1 through 7.5;</p> <p>OR</p> <p>The responsible entity did not have a Corrective Action Plan as required by Requirement R7.</p>
<b>R8.</b>	<p>The responsible entity completed a supplemental GMD Vulnerability Assessment, but it was more than 60 calendar months and less than or equal to 64 calendar months since the last supplemental GMD Vulnerability Assessment;</p> <p>OR</p> <p>The responsible entity's completed supplemental GMD Vulnerability Assessment failed to satisfy one of elements listed in Requirement R8, Parts 8.1 through 8.4;</p>	<p>The responsible entity's completed supplemental GMD Vulnerability Assessment failed to satisfy two of elements listed in Requirement R8, Parts 8.1 through 8.4;</p> <p>OR</p> <p>The responsible entity completed a supplemental GMD Vulnerability Assessment, but it was more than 64 calendar months and less than or equal to 68 calendar months since the last supplemental GMD Vulnerability Assessment.</p>	<p>The responsible entity's completed supplemental GMD Vulnerability Assessment failed to satisfy three of the elements listed in Requirement R8, Parts 8.1 through 8.4;</p> <p>OR</p> <p>The responsible entity completed a supplemental GMD Vulnerability Assessment, but it was more than 68 calendar months and less than or equal to 72 calendar months since the last supplemental GMD Vulnerability Assessment.</p>	<p>The responsible entity's completed supplemental GMD Vulnerability Assessment failed to satisfy four of the elements listed in Requirement R8, Parts 8.1 through 8.4;</p> <p>OR</p> <p>The responsible entity completed a supplemental GMD Vulnerability Assessment, but it was more than 72 calendar months since the last supplemental GMD Vulnerability Assessment;</p> <p>OR</p> <p>The responsible entity does not have a completed supplemental GMD Vulnerability Assessment.</p>

<p><b>R9.</b></p>	<p>The responsible entity provided the effective GIC time series, GIC(t), in response to written request, but did so more than 90 calendar days and less than or equal to 100 calendar days after receipt of a written request.</p>	<p>The responsible entity provided the effective GIC time series, GIC(t), in response to written request, but did so more than 100 calendar days and less than or equal to 110 calendar days after receipt of a written request.</p>	<p>The responsible entity provided the effective GIC time series, GIC(t), in response to written request, but did so more than 110 calendar days after receipt of a written request.</p>	<p>The responsible entity did not provide the maximum effective GIC value to the Transmission Owner and Generator Owner that owns each applicable BES power transformer in the planning area; OR The responsible entity did not provide the effective GIC time series, GIC(t), upon written request.</p>
<p><b>R10.</b></p>	<p>The responsible entity failed to conduct a supplemental thermal impact assessment for 5% or less or one of its solely owned and jointly owned applicable BES power transformers (whichever is greater) where the maximum effective GIC value provided in Requirement R9, Part 9.1, is 85 A or greater per phase; OR The responsible entity conducted a supplemental thermal impact assessment</p>	<p>The responsible entity failed to conduct a supplemental thermal impact assessment for more than 5% up to (and including) 10% or two of its solely owned and jointly owned applicable BES power transformers (whichever is greater) where the maximum effective GIC value provided in Requirement R9, Part 9.1, is 85 A or greater per phase; OR The responsible entity conducted a supplemental</p>	<p>The responsible entity failed to conduct a supplemental thermal impact assessment for more than 10% up to (and including) 15% or three of its solely owned and jointly owned applicable BES power transformers (whichever is greater) where the maximum effective GIC value provided in Requirement R9, Part 9.1, is 85 A or greater per phase; OR The responsible entity conducted a supplemental</p>	<p>The responsible entity failed to conduct a supplemental thermal impact assessment for more than 15% or more than three of its solely owned and jointly owned applicable BES power transformers (whichever is greater) where the maximum effective GIC value provided in Requirement R9, Part 9.1, is 85 A or greater per phase; OR The responsible entity conducted a supplemental</p>



	<p>for its solely owned and jointly owned applicable BES power transformers where the maximum effective GIC value provided in Requirement R9, Part 9.1, is 85 A or greater per phase but did so more than 24 calendar months and less than or equal to 26 calendar months of receiving GIC flow information specified in Requirement R9, Part 9.1.</p>	<p>thermal impact assessment for its solely owned and jointly owned applicable BES power transformers where the maximum effective GIC value provided in Requirement R9, Part 9.1, is 85 A or greater per phase but did so more than 26 calendar months and less than or equal to 28 calendar months of receiving GIC flow information specified in Requirement R9, Part 9.1; OR The responsible entity failed to include one of the required elements as listed in Requirement R10, Parts 10.1 through 10.3.</p>	<p>thermal impact assessment for its solely owned and jointly owned applicable BES power transformers where the maximum effective GIC value provided in Requirement R9, Part 9.1, is 85 A or greater per phase but did so more than 28 calendar months and less than or equal to 30 calendar months of receiving GIC flow information specified in Requirement R9, Part 9.1; OR The responsible entity failed to include two of the required elements as listed in Requirement R10, Parts 10.1 through 10.3.</p>	<p>thermal impact assessment for its solely owned and jointly owned applicable BES power transformers where the maximum effective GIC value provided in Requirement R9, Part 9.1, is 85 A or greater per phase but did so more than 30 calendar months of receiving GIC flow information specified in Requirement R9, Part 9.1; OR The responsible entity failed to include three of the required elements as listed in Requirement R10, Parts 10.1 through 10.3.</p>
<b>R11.</b>	N/A	N/A	N/A	<p>The responsible entity did not implement a process to obtain GIC monitor data from at least one GIC monitor located in the Planning Coordinator’s planning area or other part of the system included in the Planning Coordinator’s GIC System Model.</p>

<b>R12.</b>	N/A	N/A	N/A	The responsible entity did not implement a process to obtain geomagnetic field data for its Planning Coordinator’s planning area.
-------------	-----	-----	-----	---

**D. Regional Variances**

None.

**E. Associated Documents**

None.

## Version History

Version	Date	Action	Change Tracking
1	December 17, 2014	Adopted by the NERC Board of Trustees	
2	TBD	Revised to respond to directives in FERC Order No. 830.	Revised

## **Standard Attachments**

The following attachments are part of TPL-007-2.

## Attachment 1

### Calculating Geoelectric Fields for the Benchmark and Supplemental GMD Events

The benchmark GMD event<sup>1</sup> defines the geoelectric field values used to compute GIC flows that are needed to conduct a benchmark GMD Vulnerability Assessment. It is composed of the following elements: (1) a reference peak geoelectric field amplitude of 8 V/km derived from statistical analysis of historical magnetometer data; (2) scaling factors to account for local geomagnetic latitude; (3) scaling factors to account for local earth conductivity; and (4) a reference geomagnetic field time series or waveform to facilitate time-domain analysis of GMD impact on equipment.

The supplemental GMD event is composed of similar elements as described above, except (1) the reference peak geoelectric field amplitude is 12 V/km over a localized area; and (2) the geomagnetic field time series or waveform includes a local enhancement in the waveform.<sup>2</sup>

The regional geoelectric field peak amplitude used in GMD Vulnerability Assessment,  $E_{\text{peak}}$ , can be obtained from the reference geoelectric field value of 8 V/km for the benchmark GMD event (1) or 12 V/km for the supplemental GMD event (2) using the following relationships:

$$E_{\text{peak}} = 8 \times \alpha \times \beta_b \text{ (V/km)} \quad (1)$$

$$E_{\text{peak}} = 12 \times \alpha \times \beta_s \text{ (V/km)} \quad (2)$$

where  $\alpha$  is the scaling factor to account for local geomagnetic latitude, and  $\beta$  is a scaling factor to account for the local earth conductivity structure. Subscripts  $b$  and  $s$  for the  $\beta$  scaling factor denote association with the benchmark or supplemental GMD events, respectively.

#### Scaling the Geomagnetic Field

The benchmark and supplemental GMD events are defined for geomagnetic latitude of 60° and must be scaled to account for regional differences based on geomagnetic latitude. Table 2 provides a scaling factor correlating peak geoelectric field to geomagnetic latitude.

Alternatively, the scaling factor  $\alpha$  is computed with the empirical expression

$$\alpha = 0.001 \cdot e^{(0.115 \cdot L)} \quad (3)$$

where  $L$  is the geomagnetic latitude in degrees and  $0.1 \leq \alpha \leq 1$ .

<sup>1</sup> The benchmark GMD event description is available on the Related Information page for TPL-007-1: <http://www.nerc.com/pa/stand/Pages/TPL0071RI.aspx>

<sup>2</sup> The extent of local enhancements is on the order of 100 km in North-South (latitude) direction but longer in East-West (longitude) direction. The local enhancement in the geomagnetic field occurs over the time period of 2-5 minutes. Additional information is available in the Supplemental GMD Event Description white paper on the Project 2013-03 Geomagnetic Disturbance Mitigation project page: <http://www.nerc.com/pa/Stand/Pages/Project-2013-03-Geomagnetic-Disturbance-Mitigation.aspx>

For large planning areas that cover more than one scaling factor from Table 2, the GMD Vulnerability Assessment should be based on a peak geoelectric field that is:

- calculated by using the most conservative (largest) value for  $\alpha$ ; or
- calculated assuming a non-uniform or piecewise uniform geomagnetic field.

Geomagnetic Latitude (Degrees)	Scaling Factor1 ( $\alpha$ )
≤ 40	0.10
45	0.2
50	0.3
54	0.5
56	0.6
57	0.7
58	0.8
59	0.9
≥ 60	1.0

### Scaling the Geoelectric Field

The benchmark GMD event is defined for the reference Quebec earth model described in Table 4. The peak geoelectric field,  $E_{peak}$ , used in a GMD Vulnerability Assessment may be obtained by either:

- Calculating the geoelectric field for the ground conductivity in the planning area and the reference geomagnetic field time series scaled according to geomagnetic latitude, using a procedure such as the plane wave method described in the NERC GMD Task Force GIC Application Guide;<sup>3</sup> or
- Using the earth conductivity scaling factor  $\beta$  from Table 3 that correlates to the ground conductivity map in Figure 1 or Figure 2. Along with the scaling factor  $\alpha$  from equation (3) or Table 2,  $\beta$  is applied to the reference geoelectric field using equation (1 or 2, as applicable) to obtain the regional geoelectric field peak amplitude  $E_{peak}$  to be used in GMD Vulnerability Assessments. When a ground conductivity model is not available, the planning entity should use the largest  $\beta$  factor of adjacent physiographic regions or a technically justified value.

The earth models used to calculate Table 3 for the United States were obtained from publicly available information published on the U. S. Geological Survey website.<sup>4</sup> The models used to calculate Table 3 for Canada were obtained from Natural Resources Canada (NRCan) and reflect the average structure for large regions. A planner can also use specific earth model(s) with

<sup>3</sup> Available at the NERC GMD Task Force project page: [http://www.nerc.com/comm/PC/Pages/Geomagnetic-Disturbance-Task-Force-\(GMDTF\)-2013.aspx](http://www.nerc.com/comm/PC/Pages/Geomagnetic-Disturbance-Task-Force-(GMDTF)-2013.aspx)

<sup>4</sup> Available at <http://geomag.usgs.gov/conductivity/>

documented justification and the reference geomagnetic field time series to calculate the  $\beta$  factor(s) as follows:

$$\beta_b = E/8 \text{ for the benchmark GMD event} \quad (4)$$

$$\beta_s = E/12 \text{ for the supplemental GMD event} \quad (5)$$

where  $E$  is the absolute value of peak geoelectric in V/km obtained from the technically justified earth model and the reference geomagnetic field time series.

For large planning areas that span more than one  $\beta$  scaling factor, the most conservative (largest) value for  $\beta$  may be used in determining the peak geoelectric field to obtain conservative results. Alternatively, a planner could perform analysis using a non-uniform or piecewise uniform geoelectric field.

### **Applying the Localized Peak Geoelectric Field in the Supplemental GMD Event**

The peak geoelectric field of the supplemental GMD event occurs in a localized area.<sup>5</sup> Planners have flexibility to determine how to apply the localized peak geoelectric field over the planning area in performing GIC calculations. Examples of approaches are:

- Apply the peak geoelectric field (12 V/km scaled to the planning area) over the entire planning area;
- Apply a spatially limited (12 V/km scaled to the planning area) peak geoelectric field (e.g., 100 km in North-South latitude direction and 500 km in East-West longitude direction) over a portion(s) of the system, and apply the benchmark GMD event over the rest of the system; or
- Other methods to adjust the benchmark GMD event analysis to account for the localized geoelectric field enhancement of the supplemental GMD event.

---

<sup>5</sup> See the Supplemental Geomagnetic Disturbance Description white paper located on the Project 2013-03 Geomagnetic Disturbance Mitigation project page: <http://www.nerc.com/pa/Stand/Pages/Project-2013-03-Geomagnetic-Disturbance-Mitigation.aspx>

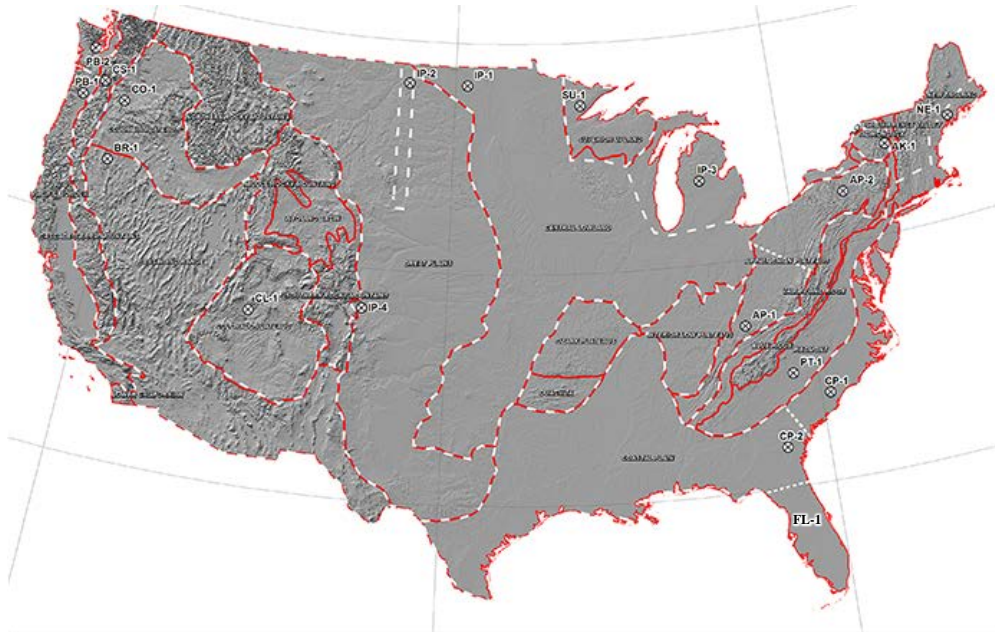


Figure 1: Physiographic Regions of the Continental United States<sup>6</sup>



Figure 2: Physiographic Regions of Canada

<sup>6</sup> Additional map detail is available at the U.S. Geological Survey (<http://geomag.usgs.gov/>)



Table 3 – Geoelectric Field Scaling Factors		
Earth model	Scaling Factor Benchmark Event ( $\beta_b$ )	Scaling Factor Supplemental Event ( $\beta_s$ )
AK1A	0.56	0.51
AK1B	0.56	0.51
AP1	0.33	0.30
AP2	0.82	0.78
BR1	0.22	0.22
CL1	0.76	0.73
CO1	0.27	0.25
CP1	0.81	0.77
CP2	0.95	0.86
FL1	0.76	0.73
CS1	0.41	0.37
IP1	0.94	0.90
IP2	0.28	0.25
IP3	0.93	0.90
IP4	0.41	0.35
NE1	0.81	0.77
PB1	0.62	0.55
PB2	0.46	0.39
PT1	1.17	1.19
SL1	0.53	0.49
SU1	0.93	0.90
BOU	0.28	0.24
FBK	0.56	0.56
PRU	0.21	0.22
BC	0.67	0.62
PRAIRIES	0.96	0.88
SHIELD	1.0	1.0
ATLANTIC	0.79	0.76

**Rationale:** Scaling factors in Table 3 are dependent upon the frequency content of the reference storm. Consequently, the benchmark GMD event and the supplemental GMD event may produce different scaling factors for a given earth model.

The scaling factor associated with the benchmark GMD event for the Florida earth model (FL-1) has been updated based on the earth model published on the USGS public website.

Layer Thickness (km)	Resistivity ( $\Omega$ -m)
15	20,000
10	200
125	1,000
200	100
$\infty$	3

### Reference Geomagnetic Field Time Series or Waveform for the Benchmark GMD Event<sup>7</sup>

The geomagnetic field measurement record of the March 13-14 1989 GMD event, measured at NRCan’s Ottawa geomagnetic observatory is the basis for the reference geomagnetic field waveform to be used to calculate the GIC time series, GIC(t), required for transformer thermal impact assessment.

The geomagnetic latitude of the Ottawa geomagnetic observatory is 55°; therefore, the amplitudes of the geomagnetic field measurement data were scaled up to the 60° reference geomagnetic latitude (see Figure 3) such that the resulting peak geoelectric field amplitude computed using the reference earth model was 8 V/km (see Figures 4 and 5). The sampling rate for the geomagnetic field waveform is 10 seconds.<sup>8</sup> To use this geoelectric field time series when a different earth model is applicable, it should be scaled with the appropriate benchmark conductivity scaling factor  $\beta_b$ .

---

<sup>7</sup> Refer to the Benchmark GMD Event Description white paper for details on the determination of the reference geomagnetic field waveform: <http://www.nerc.com/pa/stand/Pages/TPL0071RI.aspx>

<sup>8</sup> The data file of the benchmark geomagnetic field waveform is available on the Related Information page for TPL-007-1: <http://www.nerc.com/pa/stand/Pages/TPL0071RI.aspx>

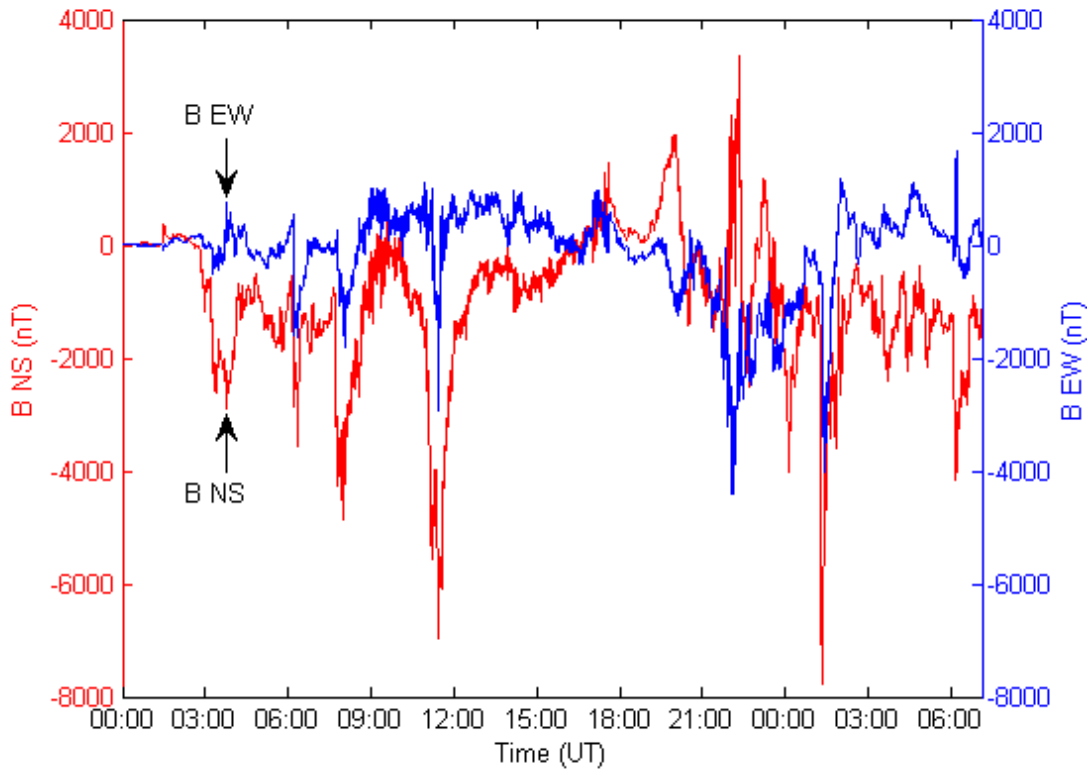


Figure 3: Benchmark Geomagnetic Field Waveform. Red  $B_n$  (Northward), Blue  $B_e$  (Eastward)

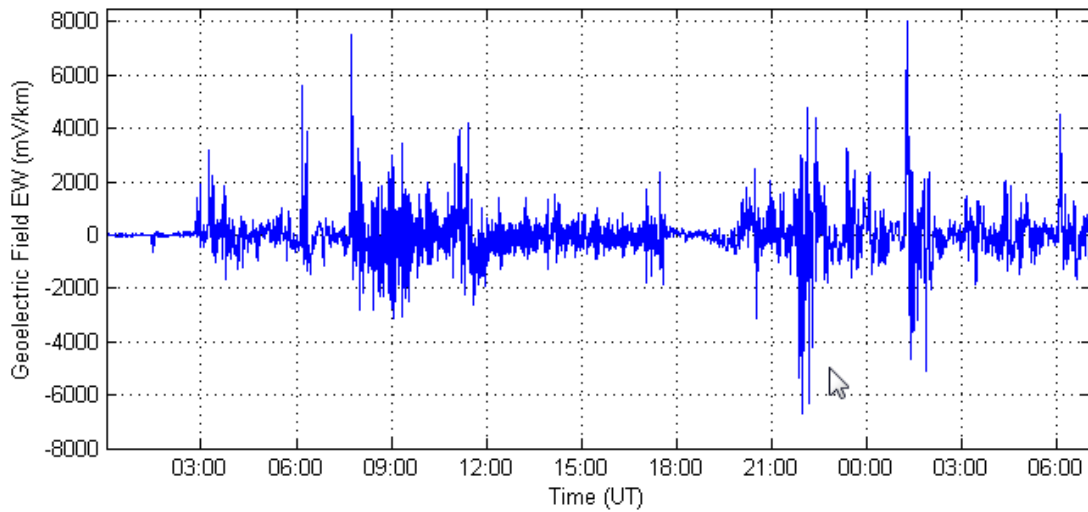
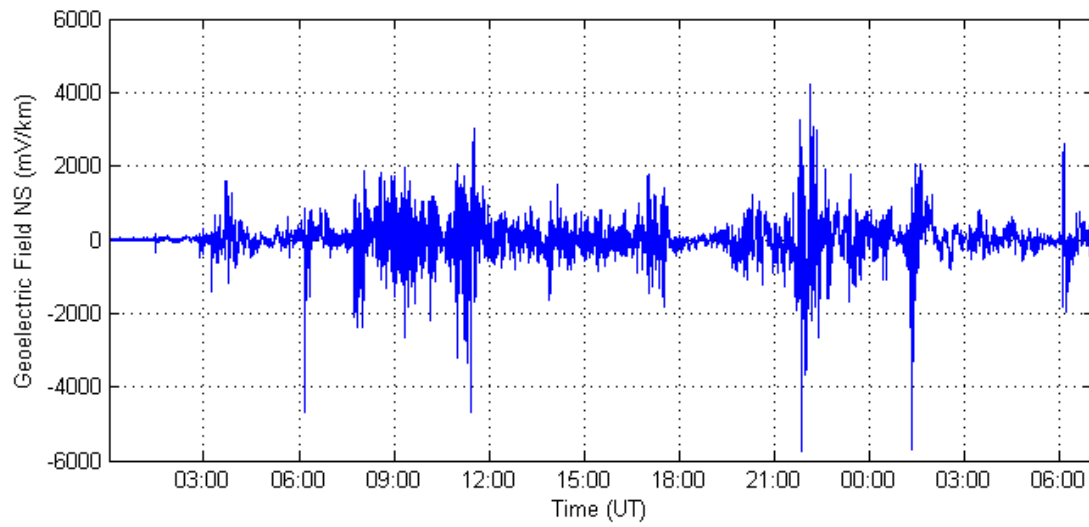


Figure 4: Benchmark Geoelectric Field Waveform -  $E_e$  (Eastward)



**Figure 5: Benchmark Geoelectric Field Waveform –  $E_N$  (Northward)**

## Reference Geomagnetic Field Time Series or Waveform for the Supplemental GMD Event<sup>9</sup>

The geomagnetic field measurement record of the March 13-14, 1989 GMD event, measured at NRCan's Ottawa geomagnetic observatory is the basis for the reference geomagnetic field waveform to be used to calculate the GIC time series, GIC(t), required for transformer thermal impact assessment for the supplemental GMD event. The supplemental GMD event waveform differs from the benchmark GMD event waveform in that the supplemental GMD event waveform has a local enhancement.

The geomagnetic latitude of the Ottawa geomagnetic observatory is 55°; therefore, the amplitudes of the geomagnetic field measurement data were scaled up to the 60° reference geomagnetic latitude (see Figure 6) such that the resulting peak geoelectric field amplitude computed using the reference earth model was 12 V/km (see Figure 7). The sampling rate for the geomagnetic field waveform is 10 seconds.<sup>10</sup> To use this geoelectric field time series when a different earth model is applicable, it should be scaled with the appropriate supplemental conductivity scaling factor  $\beta_s$ .

---

<sup>9</sup> Refer to the Supplemental GMD Event Description white paper for details on the determination of the reference geomagnetic field waveform: <http://www.nerc.com/pa/Stand/Pages/Project-2013-03-Geomagnetic-Disturbance-Mitigation.aspx>

<sup>10</sup> The data file of the benchmark geomagnetic field waveform is available on the NERC GMD Task Force project page: [http://www.nerc.com/comm/PC/Pages/Geomagnetic-Disturbance-Task-Force-\(GMDTF\)-2013.aspx](http://www.nerc.com/comm/PC/Pages/Geomagnetic-Disturbance-Task-Force-(GMDTF)-2013.aspx)

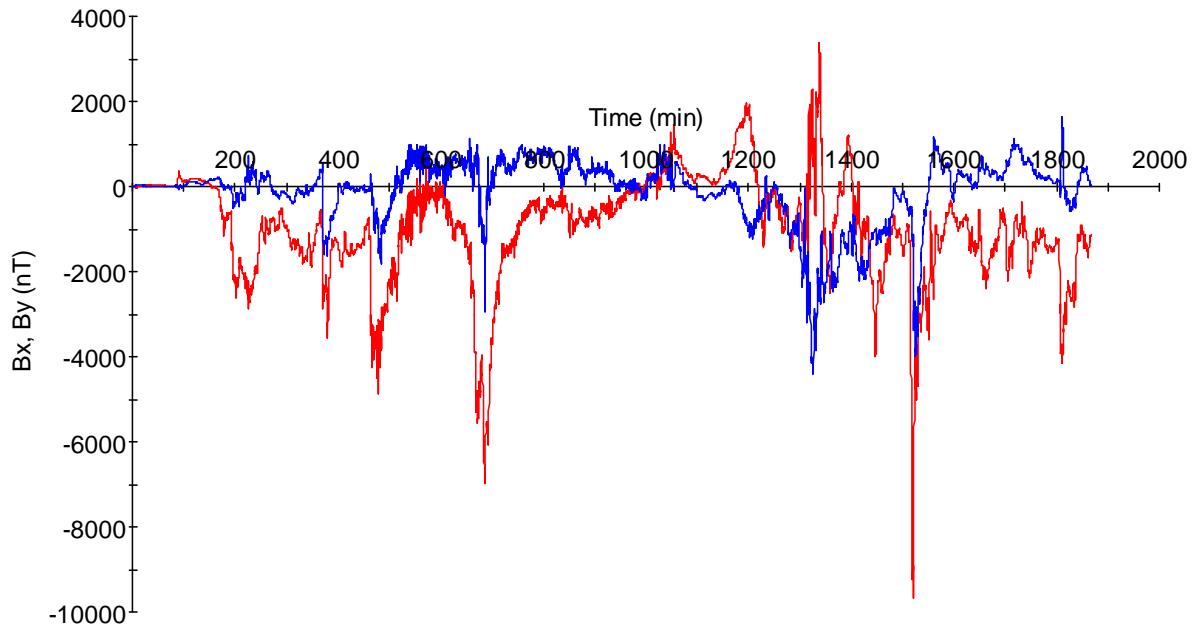


Figure 6: Supplemental Geomagnetic Field Waveform. Red B<sub>n</sub> (Northward), Blue B<sub>e</sub> (Eastward)

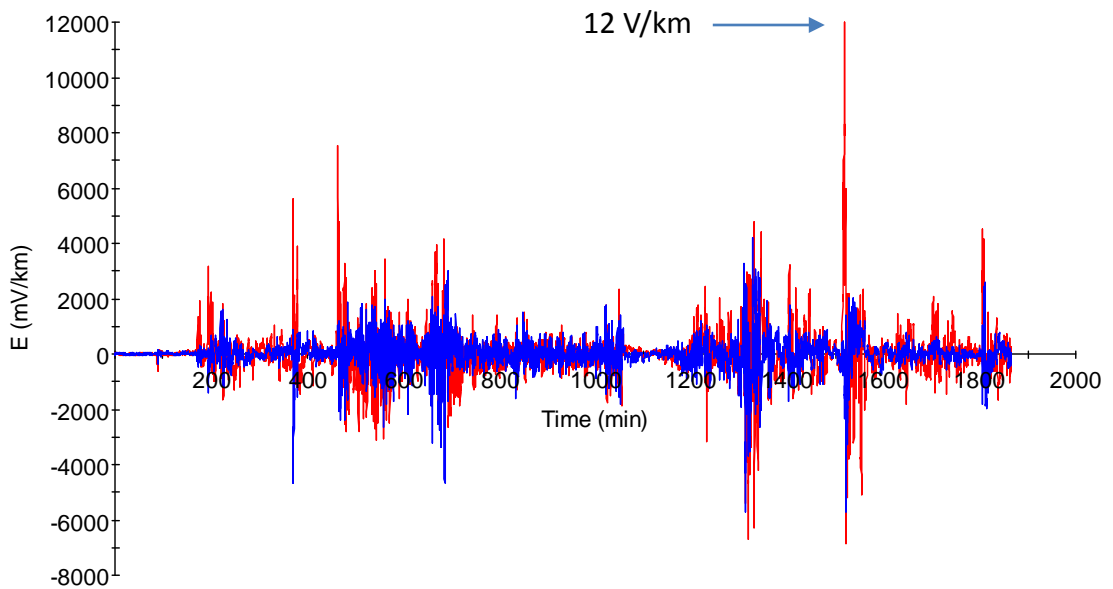
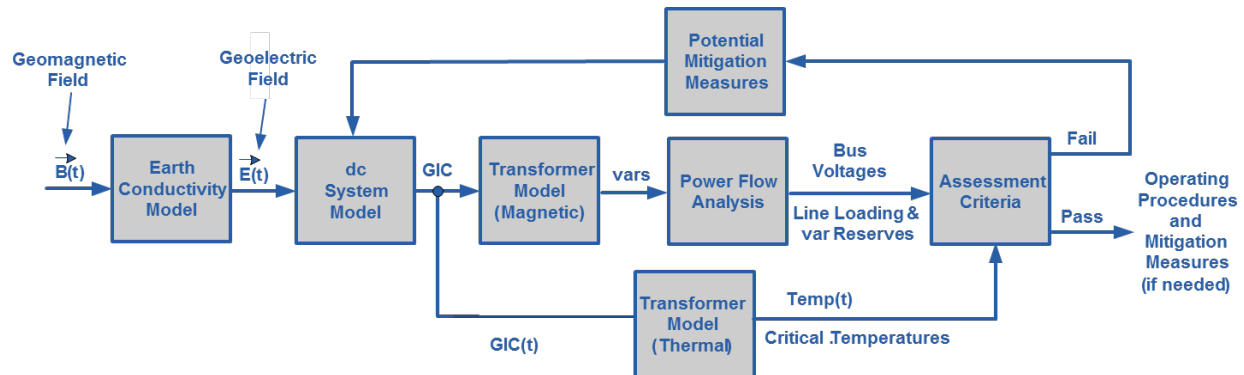


Figure 7: Supplemental Geoelectric Field Waveform. Blue E<sub>n</sub> (Northward), Red E<sub>e</sub> (Eastward)

## Guidelines and Technical Basis

The diagram below provides an overall view of the GMD Vulnerability Assessment process:



The requirements in this standard cover various aspects of the GMD Vulnerability Assessment process.

### Benchmark GMD Event (Attachment 1)

The benchmark GMD event defines the geoelectric field values used to compute GIC flows that are needed to conduct a benchmark GMD Vulnerability Assessment. A white paper that includes the event description, analysis, and example calculations is available on the Project 2013-03 Geomagnetic Disturbance Mitigation project page at:

<http://www.nerc.com/pa/stand/Pages/TPL0071RI.aspx>

### Supplemental GMD Event (Attachment 1)

The supplemental GMD event defines the geoelectric field values used to compute GIC flows that are needed to conduct a supplemental GMD Vulnerability Assessment. A white paper that includes the event description and analysis is available on the Project 2013-03 Geomagnetic Disturbance Mitigation project page:

<http://www.nerc.com/pa/Stand/Pages/Project-2013-03-Geomagnetic-Disturbance-Mitigation.aspx>

### Requirement R2

A GMD Vulnerability Assessment requires a GIC System model, which is a dc representation of the System, to calculate GIC flow. In a GMD Vulnerability Assessment, GIC simulations are used to determine transformer Reactive Power absorption and transformer thermal response.

Details for developing the GIC System model are provided in the NERC GMD Task Force guide: *Application Guide for Computing Geomagnetically-Induced Current in the Bulk Power System*.

The guide is available at:

[http://www.nerc.com/comm/PC/Geomagnetic%20Disturbance%20Task%20Force%20GMDTF%202013/GIC%20Application%20Guide%202013\\_approved.pdf](http://www.nerc.com/comm/PC/Geomagnetic%20Disturbance%20Task%20Force%20GMDTF%202013/GIC%20Application%20Guide%202013_approved.pdf)

Underground pipe-type cables present a special modeling situation in that the steel pipe that encloses the power conductors significantly reduces the geoelectric field induced into the conductors themselves, while they remain a path for GIC. Solid dielectric cables that are not

enclosed by a steel pipe will not experience a reduction in the induced geoelectric field. A planning entity should account for special modeling situations in the GIC system model, if applicable.

#### **Requirement R4**

The *GMD Planning Guide* developed by the NERC GMD Task Force provides technical information on GMD-specific considerations for planning studies. It is available at: [http://www.nerc.com/comm/PC/Geomagnetic%20Disturbance%20Task%20Force%20GMDTF%202013/GMD%20Planning%20Guide\\_approved.pdf](http://www.nerc.com/comm/PC/Geomagnetic%20Disturbance%20Task%20Force%20GMDTF%202013/GMD%20Planning%20Guide_approved.pdf)

#### **Requirement R5**

The benchmark thermal impact assessment of transformers specified in Requirement R6 is based on GIC information for the benchmark GMD Event. This GIC information is determined by the planning entity through simulation of the GIC System model and must be provided to the entity responsible for conducting the thermal impact assessment. GIC information should be provided in accordance with Requirement R5 each time the GMD Vulnerability Assessment is performed since, by definition, the GMD Vulnerability Assessment includes a documented evaluation of susceptibility to localized equipment damage due to GMD.

The maximum effective GIC value provided in Part 5.1 is used for the benchmark thermal impact assessment. Only those transformers that experience an effective GIC value of 75 A or greater per phase require evaluation in Requirement R6.

GIC(t) provided in Part 5.2 is used to convert the steady state GIC flows to time-series GIC data for the benchmark thermal impact assessment of transformers. This information may be needed by one or more of the methods for performing a benchmark thermal impact assessment. Additional information is in the following section and the thermal impact assessment white paper.

The peak GIC value of 75 Amps per phase has been shown through thermal modeling to be a conservative threshold below which the risk of exceeding known temperature limits established by technical organizations is low.

#### **Requirement R6**

The benchmark thermal impact assessment of a power transformer may be based on manufacturer-provided GIC capability curves, thermal response simulation, thermal impact screening, or other technically justified means. Approaches for conducting the assessment are presented in the *Transformer Thermal Impact Assessment* white paper. The ERO enterprise has endorsed the white paper as Implementation Guidance for this requirement. The white paper is posted on the NERC compliance guidance page: <http://www.nerc.com/pa/comp/guidance/Pages/default.aspx>

Transformers are exempt from the benchmark thermal impact assessment requirement if the effective GIC value for the transformer is less than 75 A per phase, as determined by a GIC



analysis of the System. Justification for this criterion is provided in the *Screening Criterion for Transformer Thermal Impact Assessment* white paper posted on the Related Information page for TPL-007-1. A documented design specification exceeding this value is also a justifiable threshold criterion that exempts a transformer from Requirement R6.

The benchmark threshold criteria and its associated transformer thermal impact must be evaluated on the basis of effective GIC. Refer to the white papers for additional information.

### **Requirement R7**

Technical considerations for GMD mitigation planning, including operating and equipment strategies, are available in Chapter 5 of the *GMD Planning Guide*. Additional information is available in the *2012 Special Reliability Assessment Interim Report: Effects of Geomagnetic Disturbances on the Bulk-Power System*:

<http://www.nerc.com/pa/RAPA/ra/Reliability%20Assessments%20DL/2012GMD.pdf>

### **Requirement R8**

The *GMD Planning Guide* developed by the NERC GMD Task Force provides technical information on GMD-specific considerations for planning studies. It is available at:

[http://www.nerc.com/comm/PC/Geomagnetic%20Disturbance%20Task%20Force%20GMDTF%202013/GMD%20Planning%20Guide\\_approved.pdf](http://www.nerc.com/comm/PC/Geomagnetic%20Disturbance%20Task%20Force%20GMDTF%202013/GMD%20Planning%20Guide_approved.pdf)

[The supplemental GMD Vulnerability Assessment process is similar to the benchmark GMD Vulnerability Assessment process described under Requirement R4.](#)

### **Requirement R9**

The supplemental thermal impact assessment specified of transformers in Requirement R10 is based on GIC information for the supplemental GMD Event. This GIC information is determined by the planning entity through simulation of the GIC System model and must be provided to the entity responsible for conducting the thermal impact assessment. GIC information should be provided in accordance with Requirement R9 each time the GMD Vulnerability Assessment is performed since, by definition, the GMD Vulnerability Assessment includes a documented evaluation of susceptibility to localized equipment damage due to GMD.

The maximum effective GIC value provided in Part 9.1 is used for the supplemental thermal impact assessment. Only those transformers that experience an effective GIC value of 85 A or greater per phase require evaluation in Requirement R10.

GIC(t) provided in Part 9.2 is used to convert the steady state GIC flows to time-series GIC data for the supplemental thermal impact assessment of transformers. This information may be needed by one or more of the methods for performing a supplemental thermal impact assessment. Additional information is in the following section.

The peak GIC value of 85 Amps per phase has been shown through thermal modeling to be a conservative threshold below which the risk of exceeding known temperature limits established by technical organizations is low.

### Requirement R10

The supplemental thermal impact assessment of a power transformer may be based on manufacturer-provided GIC capability curves, thermal response simulation, thermal impact screening, or other technically justified means. Approaches for conducting the assessment are presented in the *Transformer Thermal Impact Assessment* white paper discussed in the Requirement R6 section above. A revised version of the Transformer Thermal Impact Assessment white paper has been developed to include updated information pertinent to the supplemental GMD event and supplemental thermal impact assessment. This revised white paper is posted on the project page at:

<http://www.nerc.com/pa/Stand/Pages/Project-2013-03-Geomagnetic-Disturbance-Mitigation.aspx>

Transformers are exempt from the supplemental thermal impact assessment requirement if the effective GIC value for the transformer is less than 85 A per phase, as determined by a GIC analysis of the System. Justification for this criterion is provided in the revised *Screening Criterion for Transformer Thermal Impact Assessment* white paper posted on the project page. A documented design specification exceeding this value is also a justifiable threshold criterion that exempts a transformer from Requirement R10.

The supplemental threshold criteria and its associated transformer thermal impact must be evaluated on the basis of effective GIC. Refer to the white papers for additional information.

### Requirement R11

Technical considerations for GIC monitoring are contained in the NERC 2012 GMD Report (see Chapter 6). GIC monitoring is generally performed by Hall effect transducers that are attached to the neutral of the wye-grounded transformer. Data from GIC monitors is useful for model validation and situational awareness.

Responsible entities consider the following in developing a process for obtaining GIC monitor data:

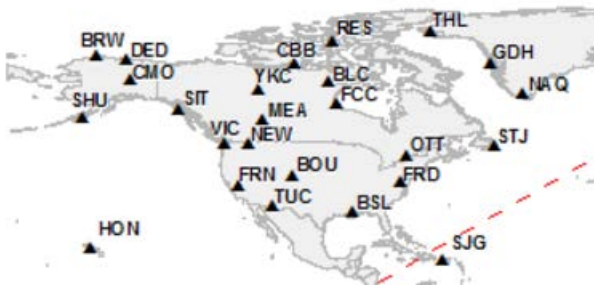
- **Monitor locations.** An entity's operating process may be constrained by location of existing GIC monitors. However, when planning for additional GIC monitoring installations consider that data from monitors located in areas found to have high GIC based on system studies may provide more useful information for validation and situational awareness purposes. Conversely, data from GIC monitors that are located in the vicinity of transportation systems using direct current (e.g., subways or light rail) may be unreliable.
- **Monitor specifications.** Capabilities of Hall effect transducers, existing and planned, should be considered in the operating process. When planning new GIC monitor installations, consider monitor data range (e.g., -500 A through + 500 A) and ambient temperature ratings consistent with temperatures in the region in which the monitor will be installed.

- **Sampling Interval.** An entity's operating process may be constrained by capabilities of existing GIC monitors. However, when possible specify data sampling during periods of interest at a rate of 10 seconds or faster.
- **Collection Periods.** The process should specify when the entity expects GIC data to be collected. For example, collection could be required during periods where the Kp index is above a threshold, or when GIC values are above a threshold. Determining when to discontinue collecting GIC data should also be specified to maintain consistency in data collection.
- **Data format.** Specify time and value formats. For example, Greenwich Mean Time (GMT) (MM/DD/YYYY HH:MM:SS) and GIC Value (Ampere). Positive (+) and negative (-) signs indicate direction of GIC flow. Positive reference is flow from ground into transformer neutral. Time fields should indicate the sampled time rather than system or SCADA time if supported by the GIC monitor system.
- **Data retention.** The entity's process should specify data retention periods, for example 1 year. Data retention periods should be adequately long to support availability for the entity's model validation process and external reporting requirements, if any.
- **Additional information.** The entity's process should specify collection of other information necessary for making the data useful, for example monitor location and type of neutral connection (e.g., three-phase or single-phase).

### Requirement R12

Magnetometers measure changes in the earth's magnetic field. Entities should obtain data from the nearest accessible magnetometer. Sources of magnetometer data include:

- Observatories such as those operated by U.S. Geological Survey and Natural Resources Canada, see figure below for locations (<http://www.intermagnet.org/>):



- Research institutions and academic universities;
- Entities with installed magnetometers.

Entities that choose to install magnetometers should consider equipment specifications and data format protocols contained in the latest version of the Intermagnet Technical Reference Manual, which is available at:

[http://www.intermagnet.org/publications/intermag\\_4-6.pdf](http://www.intermagnet.org/publications/intermag_4-6.pdf)

## Rationale

During development of TPL-007-1, text boxes were embedded within the standard to explain the rationale for various parts of the standard. The text from the rationale text boxes was moved to this section upon approval of TPL-007-1 by the NERC Board of Trustees. In developing TPL-007-2, the SDT has made changes to the sections below only when necessary for clarity. Changes are marked with brackets [ ].

### **Rationale for Applicability:**

Instrumentation transformers and station service transformers do not have significant impact on geomagnetically-induced current (GIC) flows; therefore, these transformers are not included in the applicability for this standard.

Terminal voltage describes line-to-line voltage.

### **Rationale for R1:**

In some areas, planning entities may determine that the most effective approach to conduct a GMD Vulnerability Assessment is through a regional planning organization. No requirement in the standard is intended to prohibit a collaborative approach where roles and responsibilities are determined by a planning organization made up of one or more Planning Coordinator(s).

### **Rationale for R2:**

A GMD Vulnerability Assessment requires a GIC System model to calculate GIC flow which is used to determine transformer Reactive Power absorption and transformer thermal response. Guidance for developing the GIC System model is provided in the GIC Application Guide developed by the NERC GMD Task Force and available at:

[http://www.nerc.com/comm/PC/Geomagnetic%20Disturbance%20Task%20Force%20GMDTF%202013/GIC%20Application%20Guide%202013\\_approved.pdf](http://www.nerc.com/comm/PC/Geomagnetic%20Disturbance%20Task%20Force%20GMDTF%202013/GIC%20Application%20Guide%202013_approved.pdf)

The System model specified in Requirement R2 is used in conducting steady state power flow analysis that accounts for the Reactive Power absorption of power transformer(s) due to GIC in the System.

The GIC System model includes all power transformer(s) with a high side, wye-grounded winding with terminal voltage greater than 200 kV. The model is used to calculate GIC flow in the network.

The projected System condition for GMD planning may include adjustments to the System that are executable in response to space weather information. These adjustments could include, for example, recalling or postponing maintenance outages.

The Violation Risk Factor (VRF) for Requirement R2 is changed from Medium to High. This change is for consistency with the VRF for approved standard TPL-001-4 Requirement R1, which is proposed for revision in the NERC filing dated August 29, 2014 (RM12-1-000). NERC guidelines require consistency among Reliability Standards.

### **Rationale for R3:**

Requirement R3 allows a responsible entity the flexibility to determine the System steady state voltage criteria for System steady state performance in Table 1. Steady state voltage limits are an example of System steady state performance criteria.

**Rationale for R4:**

The GMD Vulnerability Assessment includes steady state power flow analysis and the supporting study or studies using the models specified in Requirement R2 that account for the effects of GIC. Performance criteria are specified in Table 1.

At least one System On-Peak Load and at least one System Off-Peak Load must be examined in the analysis.

Distribution of GMD Vulnerability Assessment results provides a means for sharing relevant information with other entities responsible for planning reliability. Results of GIC studies may affect neighboring systems and should be taken into account by planners.

The GMD Planning Guide developed by the NERC GMD Task Force provides technical information on GMD-specific considerations for planning studies. It is available at:

[http://www.nerc.com/comm/PC/Geomagnetic%20Disturbance%20Task%20Force%20GMDTF%202013/GMD%20Planning%20Guide\\_approved.pdf](http://www.nerc.com/comm/PC/Geomagnetic%20Disturbance%20Task%20Force%20GMDTF%202013/GMD%20Planning%20Guide_approved.pdf)

The provision of information in Requirement R4, Part 4.3, shall be subject to the legal and regulatory obligations for the disclosure of confidential and/or sensitive information.

**Rationale for R5:**

This GIC information is necessary for determining the thermal impact of GIC on transformers in the planning area and must be provided to entities responsible for performing the thermal impact assessment so that they can accurately perform the assessment. GIC information should be provided in accordance with Requirement R5 as part of the GMD Vulnerability Assessment process since, by definition, the GMD Vulnerability Assessment includes documented evaluation of susceptibility to localized equipment damage due to GMD.

The maximum effective GIC value provided in Part 5.1 is used for transformer thermal impact assessment.

GIC(t) provided in Part 5.2 can alternatively be used to convert the steady state GIC flows to time-series GIC data for transformer thermal impact assessment. This information may be needed by one or more of the methods for performing a thermal impact assessment. Additional guidance is available in the Transformer Thermal Impact Assessment white paper:

<http://www.nerc.com/pa/comp/guidance/Pages/default.aspx>

A Transmission Owner or Generator Owner that desires GIC(t) may request it from the planning entity. The planning entity shall provide GIC(t) upon request once GIC has been calculated, but no later than 90 calendar days after receipt of a request from the owner and after completion of Requirement R5, Part 5.1.

The provision of information in Requirement R5 shall be subject to the legal and regulatory obligations for the disclosure of confidential and/or sensitive information.

**Rationale for R6:**

The transformer thermal impact screening criterion has been revised from 15 A per phase to 75 A per phase [for the benchmark GMD event]. Only those transformers that experience an

effective GIC value of 75 A per phase or greater require evaluation in Requirement R6. The justification is provided in the Thermal Screening Criterion white paper.

The thermal impact assessment may be based on manufacturer-provided GIC capability curves, thermal response simulation, thermal impact screening, or other technically justified means. The transformer thermal assessment will be repeated or reviewed using previous assessment results each time the planning entity performs a GMD Vulnerability Assessment and provides GIC information as specified in Requirement R5. Approaches for conducting the assessment are presented in the Transformer Thermal Impact Assessment white paper posted on the project page.

<http://www.nerc.com/pa/Stand/Pages/Project-2013-03-Geomagnetic-Disturbance-Mitigation.aspx>

Thermal impact assessments are provided to the planning entity, as determined in Requirement R1, so that identified issues can be included in the GMD Vulnerability Assessment (R4), and the Corrective Action Plan (R7) as necessary.

Thermal impact assessments of non-BES transformers are not required because those transformers do not have a wide-area effect on the reliability of the interconnected Transmission system.

The provision of information in Requirement R6, Part 6.4, shall be subject to the legal and regulatory obligations for the disclosure of confidential and/or sensitive information.

**Rationale for R7:**

Corrective Action Plans are defined in the NERC Glossary of Terms:

*A list of actions and an associated timetable for implementation to remedy a specific problem.*

Corrective Action Plans must, subject to the vulnerabilities identified in the assessments, contain strategies for protecting against the potential impact of the benchmark GMD event, based on factors such as the age, condition, technical specifications, system configuration, or location of specific equipment. Chapter 5 of the NERC GMD Task Force *GMD Planning Guide* provides a list of mitigating measures that may be appropriate to address an identified performance issue.

The provision of information in Requirement R7, Part 7.3 [Part 7.5 in TPL-007-2], shall be subject to the legal and regulatory obligations for the disclosure of confidential and/or sensitive information.

**Rationale for Table 3:**

Table 3 has been revised to use the same ground model designation, FL1, as is being used by USGS. The calculated scaling factor for FL1 is 0.74. [The scaling factor associated with the benchmark GMD event for the Florida earth model (FL1) has been updated to 0.76 in TPL-007-2 based on the earth model published on the USGS public website.]

## A. Introduction

1. **Title:** Transmission System Planned Performance for Geomagnetic Disturbance Events
2. **Number:** TPL-007-42
3. **Purpose:** Establish requirements for Transmission system planned performance during geomagnetic disturbance (GMD) events.
4. **Applicability:**
  - 4.1. **Functional Entities:**
    - 4.1.1 Planning Coordinator with a planning area that includes a Facility or Facilities specified in 4.2;
    - 4.1.2 Transmission Planner with a planning area that includes a Facility or Facilities specified in 4.2;
    - 4.1.3 Transmission Owner who owns a Facility or Facilities specified in 4.2;
    - 4.1.4 Generator Owner who owns a Facility or Facilities specified in 4.2.
  - 4.2. **Facilities:**
    - 4.2.1 Facilities that include power transformer(s) with a high side, wye-grounded winding with terminal voltage greater than 200 kV.
5. **Background:**

During a GMD event, geomagnetically-induced currents (GIC) may cause transformer hot-spot heating or damage, loss of Reactive Power sources, increased Reactive Power demand, and Misoperation(s), the combination of which may result in voltage collapse and blackout.
6. **Effective Date:**

See Implementation Plan for TPL-007-42

## B. Requirements and Measures

- R1. Each Planning Coordinator, in conjunction with its Transmission Planner(s), shall identify the individual and joint responsibilities of the Planning Coordinator and Transmission Planner(s) in the Planning Coordinator's planning area for maintaining models ~~and~~, performing the study or studies needed to complete benchmark and supplemental GMD Vulnerability Assessment(s), and implementing process(es) to obtain GMD measurement data as specified in this standard. [Violation Risk Factor: Lower] [Time Horizon: Long-term Planning]
- M1. Each Planning Coordinator, in conjunction with its Transmission Planners, shall provide documentation on roles and responsibilities, such as meeting minutes, agreements, copies of procedures or protocols in effect between entities or between departments of a vertically integrated system, or email correspondence that identifies an agreement has been reached on individual and joint responsibilities for maintaining models ~~and~~,

performing the study or studies needed to complete benchmark and supplemental GMD Vulnerability Assessment(s), and implementing process(es) to obtain GMD Measurement Data in accordance with Requirement R1.

- R2.** Each responsible entity, as determined in Requirement R1, shall maintain System models and GIC System models of the responsible entity's planning area for performing the study or studies needed to complete benchmark and supplemental GMD Vulnerability Assessment(s). *[Violation Risk Factor: High] [Time Horizon: Long-term Planning]*
- M2.** Each responsible entity, as determined in Requirement R1, shall have evidence in either electronic or hard copy format that it is maintaining System models and GIC System models of the responsible entity's planning area for performing the study or studies needed to complete benchmark and supplemental GMD Vulnerability Assessment(s).
- R3.** Each responsible entity, as determined in Requirement R1, shall have criteria for acceptable System steady state voltage performance for its System during the benchmark GMD event events described in Attachment 1. *[Violation Risk Factor: Medium] [Time Horizon: Long-term Planning]*
- M3.** Each responsible entity, as determined in Requirement R1, shall have evidence, such as electronic or hard copies of the criteria for acceptable System steady state voltage performance for its System in accordance with Requirement R3.

#### Benchmark GMD Vulnerability Assessment(s)

- R4.** Each responsible entity, as determined in Requirement R1, shall complete a benchmark GMD Vulnerability Assessment of the Near-Term Transmission Planning Horizon at least once every 60 calendar months. This benchmark GMD Vulnerability Assessment shall use a study or studies based on models identified in Requirement R2, document assumptions, and document summarized results of the steady state analysis. *[Violation Risk Factor: High] [Time Horizon: Long-term Planning]*
  - 4.1.** The study or studies shall include the following conditions:
    - 4.1.1.** System On-Peak Load for at least one year within the Near-Term Transmission Planning Horizon; and
    - 4.1.2.** System Off-Peak Load for at least one year within the Near-Term Transmission Planning Horizon.
  - 4.2.** The study or studies shall be conducted based on the benchmark GMD event described in Attachment 1 to determine whether the System meets the performance requirements for the steady state planning benchmark GMD event contained in Table 1.
  - 4.3.** The benchmark GMD Vulnerability Assessment shall be provided: (i) within 90 calendar days of completion to the responsible entity's Reliability Coordinator,



adjacent Planning Coordinators, and adjacent Transmission Planners, within 90 calendar days of completion, and (ii) to any functional entity that submits a written request and has a reliability-related need within 90 calendar days of receipt of such request or within 90 calendar days of completion of the benchmark GMD Vulnerability Assessment, whichever is later.

**4.3.1.** If a recipient of the benchmark GMD Vulnerability Assessment provides documented comments on the results, the responsible entity shall provide a documented response to that recipient within 90 calendar days of receipt of those comments.

**M4.** Each responsible entity, as determined in Requirement R1, shall have dated evidence such as electronic or hard copies of its benchmark GMD Vulnerability Assessment meeting all of the requirements in Requirement R4. Each responsible entity, as determined in Requirement R1, shall also provide evidence, such as email records, web postings with an electronic notice of posting, or postal receipts showing recipient and date, that it has distributed its benchmark GMD Vulnerability Assessment: (i) to the responsible entity's Reliability Coordinator, adjacent Planning Coordinators, and adjacent Transmission Planners within 90 calendar days of completion, and (ii) to any functional entity that submits a written request and has a reliability-related need within 90 calendar days of receipt of such request or within 90 calendar days of completion of the benchmark GMD Vulnerability Assessment, whichever is later, within 90 calendar days of completion to its Reliability Coordinator, adjacent Planning Coordinator(s), adjacent Transmission Planner(s), and to any functional entity who has submitted a written request and has a reliability-related need as specified in Requirement R4. Each responsible entity, as determined in Requirement R1, shall also provide evidence, such as email notices or postal receipts showing recipient and date, that it has provided a documented response to comments received on its benchmark GMD Vulnerability Assessment within 90 calendar days of receipt of those comments in accordance with Requirement R4.

**R5.** Each responsible entity, as determined in Requirement R1, shall provide GIC flow information to be used for the ~~transformer~~benchmark thermal impact assessment of transformers specified in Requirement R6 to each Transmission Owner and Generator Owner that owns an applicable Bulk Electric System (BES) power transformer in the planning area. The GIC flow information shall include: *[Violation Risk Factor: Medium]* *[Time Horizon: Long-term Planning]*

**5.1.** The maximum effective GIC value for the worst case geoelectric field orientation for the benchmark GMD event described in Attachment 1. This value shall be provided to the Transmission Owner or Generator Owner that owns each applicable BES power transformer in the planning area.

**5.2.** The effective GIC time series, GIC(t), calculated using the benchmark GMD event described in Attachment 1 in response to a written request from the Transmission Owner or Generator Owner that owns an applicable BES power

transformer in the planning area. GIC(t) shall be provided within 90 calendar days of receipt of the written request and after determination of the maximum effective GIC value in Part 5.1.

- M5.** Each responsible entity, as determined in Requirement R1, shall provide evidence, such as email records, web postings with an electronic notice of posting, or postal receipts showing recipient and date, that it has provided the maximum effective [benchmark](#) GIC value to the Transmission Owner and Generator Owner that owns each applicable BES power transformer in the planning area as specified in Requirement R5, Part 5.1. Each responsible entity, as determined in Requirement R1, shall also provide evidence, such as email records, web postings with an electronic notice of posting, or postal receipts showing recipient and date, that it has provided GIC(t) in response to a written request from the Transmission Owner or Generator Owner that owns an applicable BES power transformer in the planning area.
- R6.** Each Transmission Owner and Generator Owner shall conduct a [benchmark](#) thermal impact assessment for its solely and jointly owned applicable BES power transformers where the maximum effective GIC value provided in Requirement R5, Part 5.1, is 75 A per phase or greater. The [benchmark](#) thermal impact assessment shall: *[Violation Risk Factor: Medium] [Time Horizon: Long-term Planning]*
- 6.1.** Be based on the effective GIC flow information provided in Requirement R5;
  - 6.2.** Document assumptions used in the analysis;
  - 6.3.** Describe suggested actions and supporting analysis to mitigate the impact of GICs, if any; and
  - 6.4.** Be performed and provided to the responsible entities, as determined in Requirement R1, within 24 calendar months of receiving GIC flow information specified in Requirement R5, Part 5.1.
- M6.** Each Transmission Owner and Generator Owner shall have evidence such as electronic or hard copies of its [benchmark](#) thermal impact assessment for all of its solely and jointly owned applicable BES power transformers where the maximum effective GIC value provided in Requirement R5, Part 5.1, is 75 A per phase or greater, and shall have evidence such as email records, web postings with an electronic notice of posting, or postal receipts showing recipient and date, that it has provided its thermal impact assessment to the responsible entities as specified in Requirement R6.

**Rationale for Requirement R7:** The proposed requirement addresses directives in Order No. 830 for establishing Corrective Action Plan (CAP) deadlines associated with GMD Vulnerability Assessments. In Order No. 830, FERC directed revisions to TPL-007 such that CAPs are developed within one year from the completion of GMD Vulnerability Assessments (P. 101). Furthermore, FERC directed establishment of implementation deadlines after the completion of the CAP as follows (P. 102):

- Two years for non-hardware mitigation; and

- Four years for hardware mitigation.

The objective of Part 7.4 is to provide awareness to potentially impacted entities when implementation of planned mitigation is not achievable within the deadlines established in Part 7.3.

**R7.** Each responsible entity, as determined in Requirement R1, that concludes, through the benchmark GMD Vulnerability Assessment conducted in Requirement R4, that their System does not meet the performance requirements ~~off~~for the steady state planning benchmark GMD event contained in Table 1 shall develop a Corrective Action Plan (CAP) addressing how the performance requirements will be met. The ~~Corrective Action Plan~~CAP shall: [*Violation Risk Factor: High*] [*Time Horizon: Long-term Planning*]

**7.1.** List System deficiencies and the associated actions needed to achieve required System performance. Examples of such actions include:

- Installation, modification, retirement, or removal of Transmission and generation Facilities and any associated equipment.
- Installation, modification, or removal of Protection Systems or ~~Special Protection Systems~~Remedial Action Schemes.
- Use of Operating Procedures, specifying how long they will be needed as part of the ~~Corrective Action Plan~~CAP.
- Use of Demand-Side Management, new technologies, or other initiatives.

~~**7.2.** Be reviewed in subsequent GMD Vulnerability Assessments until it is determined that the System meets the performance requirements contained in Table 1. Be developed within one year of completion of the benchmark GMD Vulnerability Assessment.~~

~~**7.3.** Include a timetable, subject to revision by the responsible entity in Part 7.4, for implementing the selected actions from Part 7.1. The timetable shall:~~

~~**7.3.1.** Specify implementation of non-hardware mitigation, if any, within two years of development of the CAP; and~~

~~**7.3.2.** Specify implementation of hardware mitigation, if any, within four years of development of the CAP.~~

**7.4.** Be revised if situations beyond the control of the responsible entity determined in Requirement R1 prevent implementation of the CAP within the timetable for implementation provided in Part 7.3. The revised CAP shall document the following, and be updated at least once every 12 calendar months until implemented:

**7.4.1.** Circumstances causing the delay for fully or partially implementing the selected actions in Part 7.1;

7.4.2. Description of the original CAP, and any previous changes to the CAP, with the associated timetable(s) for implementing the selected actions in Part 7.1; and

7.4.3. Revisions to the selected actions in Part 7.1, if any, including utilization of Operating Procedures if applicable, and the updated timetable for implementing the selected actions.

7.2.7.5. Be provided: (i) within 90 calendar days of completion development or revision to the responsible entity's Reliability Coordinator, adjacent Planning Coordinator(s), adjacent Transmission Planner(s), and functional entities referenced in the Corrective Action Plan CAP within 90 calendar days of development or revision, and (ii) to any functional entity that submits a written request and has a reliability-related need within 90 calendar days of receipt of such request or within 90 calendar days of development or revision, whichever is later.

7.2.1.7.5.1. If a recipient of the Corrective Action Plan CAP provides documented comments on the results, the responsible entity shall provide a documented response to that recipient within 90 calendar days of receipt of those comments.

**M7.** Each responsible entity, as determined in Requirement R1, that concludes, through the benchmark GMD Vulnerability Assessment conducted in Requirement R4, that the responsible entity's System does not meet the performance requirements ~~of for the steady state planning benchmark GMD event contained in~~ Table 1 shall have evidence such as dated electronic or hard copies of its Corrective Action Plan CAP including timetable for implementing selected actions, as specified in Requirement R7. Each responsible entity, as determined in Requirement R1, shall also provide evidence, such as email records or postal receipts showing recipient and date, that it has revised its CAP if situations beyond the responsible entity's control prevent implementation of the CAP within the timetable specified. Each responsible entity, as determined in Requirement R1, shall also provide evidence, such as email records, web postings with an electronic notice of posting, or postal receipts showing recipient and date, that it has distributed its Corrective Action Plan CAP or relevant information, if any, (i) to the responsible entity's Reliability Coordinator, adjacent Planning Coordinator(s), adjacent Transmission Planner(s), and functional entities referenced in the CAP within 90 calendar days of development or revision, and (ii) to any functional entity that submits a written request and has a reliability-related need within 90 calendar days of receipt of such request or within 90 calendar days of development or revision, whichever is later, within 90 calendar days of its completion development or revision to its Reliability Coordinator, adjacent Planning Coordinator(s), adjacent Transmission Planner(s), a functional entity referenced in the Corrective Action Plan CAP, and any functional entity that submits who has submitted a written request and has a reliability-related need, as specified in Requirement R7. Each responsible entity, as determined in Requirement R1, shall also provide evidence, such as email notices or postal receipts showing recipient and date,

that it has provided a documented response to comments received on its ~~Corrective Action Plan~~CAP within 90 calendar days of receipt of those comments, in accordance with Requirement R7.

### Supplemental GMD Vulnerability Assessment(s)

**Rationale for Requirements R8 - R10:** The proposed requirements address directives in Order No. 830 for revising the benchmark GMD event used in GMD Vulnerability Assessments (P.44, P47-49). The requirements add a supplemental GMD Vulnerability Assessment based on the supplemental GMD event that accounts for localized peak geoelectric fields.

R8. Each responsible entity, as determined in Requirement R1, shall complete a supplemental GMD Vulnerability Assessment of the Near-Term Transmission Planning Horizon at least once every 60 calendar months. This supplemental GMD Vulnerability Assessment shall use a study or studies based on models identified in Requirement R2, document assumptions, and document summarized results of the steady state analysis. [Violation Risk Factor: High] [Time Horizon: Long-term Planning]

8.1. The study or studies shall include the following conditions:

8.1.1. System On-Peak Load for at least one year within the Near-Term Transmission Planning Horizon; and

8.1.2. System Off-Peak Load for at least one year within the Near-Term Transmission Planning Horizon.

8.2 The study or studies shall be conducted based on the supplemental GMD event described in Attachment 1 to determine whether the System meets the performance requirements for the steady state planning supplemental GMD event contained in Table 1.

8.3 If the analysis concludes there is Cascading caused by the supplemental GMD event described in Attachment 1, an evaluation of possible actions designed to reduce the likelihood or mitigate the consequences and adverse impacts of the event(s) shall be conducted.

8.4 The supplemental GMD Vulnerability Assessment shall be provided: (i) to the responsible entity's Reliability Coordinator, adjacent Planning Coordinators, and adjacent Transmission Planners within 90 calendar days of completion, and (ii) to any functional entity that submits a written request and has a reliability-related need within 90 calendar days of receipt of such request or within 90 calendar days of completion of the supplemental GMD Vulnerability Assessment, whichever is later.

8.4.1 If a recipient of the supplemental GMD Vulnerability Assessment provides documented comments on the results, the responsible entity

shall provide a documented response to that recipient within 90 calendar days of receipt of those comments.

**M8.** Each responsible entity, as determined in Requirement R1, shall have dated evidence such as electronic or hard copies of its supplemental GMD Vulnerability Assessment meeting all of the requirements in Requirement R8. Each responsible entity, as determined in Requirement R1, shall also provide evidence, such as email records, web postings with an electronic notice of posting, or postal receipts showing recipient and date, that it has distributed its supplemental GMD Vulnerability Assessment: (i) to the responsible entity's Reliability Coordinator, adjacent Planning Coordinators, adjacent Transmission Planners within 90 calendar days of completion, and (ii) to any functional entity that submits a written request and has a reliability-related need within 90 calendar days of receipt of such request or within 90 calendar days of completion of the supplemental GMD Vulnerability Assessment, whichever is later, as specified in Requirement R8. Each responsible entity, as determined in Requirement R1, shall also provide evidence, such as email notices or postal receipts showing recipient and date, that it has provided a documented response to comments received on its supplemental GMD Vulnerability Assessment within 90 calendar days of receipt of those comments in accordance with Requirement R8.

**R9.** Each responsible entity, as determined in Requirement R1, shall provide GIC flow information to be used for the supplemental thermal impact assessment of transformers specified in Requirement R10 to each Transmission Owner and Generator Owner that owns an applicable Bulk Electric System (BES) power transformer in the planning area. The GIC flow information shall include: *[Violation Risk Factor: Medium]* *[Time Horizon: Long-term Planning]*

**9.1.** The maximum effective GIC value for the worst case geoelectric field orientation for the supplemental GMD event described in Attachment 1. This value shall be provided to the Transmission Owner or Generator Owner that owns each applicable BES power transformer in the planning area.

**9.2.** The effective GIC time series, GIC(t), calculated using the supplemental GMD event described in Attachment 1 in response to a written request from the Transmission Owner or Generator Owner that owns an applicable BES power transformer in the planning area. GIC(t) shall be provided within 90 calendar days of receipt of the written request and after determination of the maximum effective GIC value in Part 9.1.

**M9.** Each responsible entity, as determined in Requirement R1, shall provide evidence, such as email records, web postings with an electronic notice of posting, or postal receipts showing recipient and date, that it has provided the maximum effective supplemental GIC value to the Transmission Owner and Generator Owner that owns each applicable BES power transformer in the planning area as specified in Requirement R9, Part 9.1. Each responsible entity, as determined in Requirement R1, shall also provide evidence, such as email records, web postings with an electronic notice of posting, or postal

receipts showing recipient and date, that it has provided GIC(t) in response to a written request from the Transmission Owner or Generator Owner that owns an applicable BES power transformer in the planning area.

**R10.** Each Transmission Owner and Generator Owner shall conduct a supplemental thermal impact assessment for its solely and jointly owned applicable BES power transformers where the maximum effective GIC value provided in Requirement R9, Part 9.1, is 85 A per phase or greater. The supplemental thermal impact assessment shall: [Violation Risk Factor: Medium] [Time Horizon: Long-term Planning]

10.1. Be based on the effective GIC flow information provided in Requirement R9;

10.2. Document assumptions used in the analysis;

10.3. Describe suggested actions and supporting analysis to mitigate the impact of GICs, if any; and

10.4. Be performed and provided to the responsible entities, as determined in Requirement R1, within 24 calendar months of receiving GIC flow information specified in Requirement R9, Part 9.1.

**M10.** Each Transmission Owner and Generator Owner shall have evidence such as electronic or hard copies of its supplemental thermal impact assessment for all of its solely and jointly owned applicable BES power transformers where the maximum effective GIC value provided in Requirement R9, Part 9.1, is 85 A per phase or greater, and shall have evidence such as email records, web postings with an electronic notice of posting, or postal receipts showing recipient and date, that it has provided its **supplemental** thermal impact assessment to the responsible entities as specified in Requirement R10.

### GMD Measurement Data Processes

**Rationale for Requirements R11 and R12:** The proposed requirements address directives in Order No. 830 for requiring responsible entities to collect GIC monitoring and magnetometer data as necessary to enable model validation and situational awareness (P. 88; P. 90-92). See the Guidelines and Technical Basis section of this standard for technical information.

The objective of Requirement R11 is for entities to obtain GIC data for the Planning Coordinator's planning area or other part of the system included in the Planning Coordinator's GIC System model to inform GMD Vulnerability Assessments. Technical considerations for GIC monitoring are contained in Chapter 6 of the *2012 Special Reliability Assessment Interim Report: Effects of Geomagnetic Disturbances on the Bulk-Power System* (NERC 2012 GMD Report). GIC monitoring is generally performed by Hall effect transducers that are attached to the neutral of the transformer and measure dc current flowing through the neutral.

The objective of Requirement R12 is for entities to obtain geomagnetic field data for the Planning Coordinator's planning area to inform GMD Vulnerability Assessments.

Magnetometers provide geomagnetic field data by measuring changes in the earth's magnetic field. Sources of geomagnetic field data include:

- Observatories such as those operated by U.S. Geological Survey, Natural Resources Canada, research organizations, or university research facilities.
- Installed magnetometers
- Commercial or third-party sources of geomagnetic field data

Geomagnetic field data for a Planning Coordinator's planning area is obtained from one or more of the above data sources located in the Planning Coordinator's planning area, or by obtaining a geomagnetic field data product for the Planning Coordinator's planning area from a government or research organization. The geomagnetic field data product does not need to be derived from a magnetometer or observatory within the Planning Coordinator's planning area.

**R8.R11.** Each responsible entity, as determined in Requirement R1, shall implement a process to obtain GIC monitor data from at least one GIC monitor located in the Planning Coordinator's planning area or other part of the system included in the Planning Coordinator's GIC System model. [Violation Risk Factor: Lower] [Time Horizon: Long-term Planning]

**M11.** Each responsible entity, as determined in Requirement R1, shall have evidence such as electronic or hard copies of its GIC monitor location(s) and documentation of its process to obtain GIC monitor data in accordance with Requirement R11.

**R9.R12.** Each responsible entity, as determined in Requirement R1, shall implement a process to obtain geomagnetic field data for its Planning Coordinator's planning area. [Violation Risk Factor: Lower] [Time Horizon: Long-term Planning]

**M12.** Each responsible entity, as determined in Requirement R1, shall have evidence such as electronic or hard copies of its process to obtain geomagnetic field data for its Planning Coordinator's planning area in accordance with Requirement R12.



Table 1 – Steady State Planning GMD Event				
<p><b>Steady State:</b></p> <ul style="list-style-type: none"> <li>a. Voltage collapse, Cascading and uncontrolled islanding shall not occur.</li> <li>b. Generation loss is acceptable as a consequence of the <u>steady state</u> planning <u>GMD events</u>.</li> <li>c. Planned System adjustments such as Transmission configuration changes and re-dispatch of generation are allowed if such adjustments are executable within the time duration applicable to the Facility Ratings.</li> </ul>				
Category	Initial Condition	Event	Interruption of Firm Transmission Service Allowed	Load Loss Allowed
<u>Benchmark GMD Event - GMD Event with Outages</u>	1. System as may be postured in response to space weather information <sup>1</sup> , and then 2. GMD event <sup>2</sup>	Reactive Power compensation devices and other Transmission Facilities removed as a result of Protection System operation or Misoperation due to harmonics during the GMD event	Yes <sup>3</sup>	Yes <sup>3</sup>
<u>Supplemental GMD Event - GMD Event with Outages</u>	<u>1. System as may be postured in response to space weather information<sup>1</sup>, and then</u> <u>2. GMD event<sup>2</sup></u>	<u>Reactive Power compensation devices and other Transmission Facilities removed as a result of Protection System operation or Misoperation due to harmonics during the GMD event</u>	<u>Yes</u>	<u>Yes</u>
Table 1 – Steady State Performance Footnotes				
<ul style="list-style-type: none"> <li>1. The System condition for GMD planning may include adjustments to posture the System that are executable in response to space weather information.</li> <li>2. The GMD conditions for the <u>benchmark and supplemental</u> planning <u>event events</u> are described in Attachment 1 (<del>Benchmark GMD Event</del>).</li> <li>3. Load loss as a result of manual or automatic Load shedding (e.g., UVLS) and/or curtailment of Firm Transmission Service may be used to meet BES performance requirements during studied GMD conditions. The likelihood and magnitude of Load loss or curtailment of Firm Transmission Service should be minimized.</li> </ul>				

## Attachment 1

### Calculating Geoelectric Fields for the Benchmark and Supplemental GMD EventEvents

The benchmark GMD event<sup>1</sup> defines the geoelectric field values used to compute GIC flows that are needed to conduct a benchmark GMD Vulnerability Assessment. It is composed of the following elements: (1) a reference peak geoelectric field amplitude of 8 V/km derived from statistical analysis of historical magnetometer data; (2) scaling factors to account for local geomagnetic latitude; (3) scaling factors to account for local earth conductivity; and (4) a reference geomagnetic field time series or waveshapewaveform to facilitate time-domain analysis of GMD impact on equipment.

The supplemental GMD event is composed of similar elements as described above, except (1) the reference peak geoelectric field amplitude is 12 V/km over a localized area; and (2) the geomagnetic field time series or waveform includes a local enhancement in the waveform.<sup>2</sup>

The regional geoelectric field peak amplitude used in GMD Vulnerability Assessment,  $E_{\text{peak}}$ , can be obtained from the reference geoelectric field value of 8 V/km for the benchmark GMD event (1) or 12 V/km for the supplemental GMD event (2) using the following relationships:

$$E_{\text{peak}} = 8 \times \alpha \times \beta_b \text{ (V/km)} \quad (1)$$

$$E_{\text{peak}} = 12 \times \alpha \times \beta_s \text{ (V/km)} \quad (2)$$

where  $\alpha$  is the scaling factor to account for local geomagnetic latitude, and  $\beta$  is a scaling factor to account for the local earth conductivity structure. Subscripts  $b$  and  $s$  for the  $\beta$  scaling factor denotes association with the benchmark or supplemental GMD events, respectively.

### Scaling the Geomagnetic Field

The benchmark and supplemental GMD eventisevents are defined for geomagnetic latitude of 60° and ~~it~~ must be scaled to account for regional differences based on geomagnetic latitude. Table 2 provides a scaling factor correlating peak geoelectric field to geomagnetic latitude. Alternatively, the scaling factor  $\alpha$  is computed with the empirical expression

$$\alpha = 0.001 \cdot e^{(0.115 \cdot L)} \quad (2)$$

<sup>1</sup> The benchmark GMD event description is available on the Project 2013-03 Geomagnetic Disturbance Mitigation projectRelated Information page: <http://www.nerc.com/pa/Stand/Pages/Project-2013-03-Geomagnetic-Disturbance-Mitigation.aspx> for TPL-007-1; <http://www.nerc.com/pa/stand/Pages/TPL0071RI.aspx>

<sup>2</sup> The extent of local enhancements is on the order of 100 km in North-South (latitude) direction but longer in East-West (longitude) direction. The local enhancement in the geomagnetic field occurs over the time period of 2-5 minutes. Additional information is available in the sSupplemental GMD eEvent dDescription white paper on the Project 2013-03 Geomagnetic Disturbance Mitigation project page: <http://www.nerc.com/pa/Stand/Pages/Project-2013-03-Geomagnetic-Disturbance-Mitigation.aspx>

$$\alpha = 0.001 \cdot e^{(0.115 \cdot L)} \tag{3}$$

where L is the geomagnetic latitude in degrees and  $0.1 \leq \alpha \leq 1$ .

For large planning areas that cover more than one scaling factor from Table 2, the GMD Vulnerability Assessment should be based on a peak geoelectric field that is:

- calculated by using the most conservative (largest) value for  $\alpha$ ; or
- calculated assuming a non-uniform or piecewise uniform geomagnetic field.

Table 2– Geomagnetic Field Scaling Factors for the Benchmark and Supplemental GMD Events	
Geomagnetic Latitude (Degrees)	Scaling Factor <sup>1</sup> ( $\alpha$ )
≤ 40	0.10
45	0.2
50	0.3
54	0.5
56	0.6
57	0.7
58	0.8
59	0.9
≥ 60	1.0

### Scaling the Geoelectric Field

The benchmark GMD event is defined for the reference Quebec earth model described in Table 4. The peak geoelectric field,  $E_{peak}$ , used in a GMD Vulnerability Assessment may be obtained by either:

- Calculating the geoelectric field for the ground conductivity in the planning area and the reference geomagnetic field time series scaled according to geomagnetic latitude, using a procedure such as the plane wave method described in the NERC GMD Task Force GIC Application Guide;<sup>3</sup> or
- Using the earth conductivity scaling factor  $\beta$  from Table 3 that correlates to the ground conductivity map in Figure 1 or Figure 2. Along with the scaling factor  $\alpha$  from equation (23) or Table 2,  $\beta$  is applied to the reference geoelectric field using equation (1 or 2, as applicable) to obtain the regional geoelectric field peak amplitude  $E_{peak}$  to be used in GMD Vulnerability Assessments. When a ground conductivity model is not

<sup>3</sup> Available at the NERC GMD Task Force project page: [http://www.nerc.com/comm/PC/Pages/Geomagnetic-Disturbance-Task-Force-\(GMDTF\)-2013.aspx](http://www.nerc.com/comm/PC/Pages/Geomagnetic-Disturbance-Task-Force-(GMDTF)-2013.aspx)

available, the planning entity should use the largest  $\beta$  factor of adjacent physiographic regions or a technically justified value.

The earth models used to calculate Table 3 for the United States were obtained from publicly available information published on the U. S. Geological Survey website.<sup>4</sup> The models used to calculate Table 3 for Canada were obtained from Natural Resources Canada (NRCan) and reflect the average structure for large regions. A planner can also use specific earth model(s) with documented justification and the reference geomagnetic field time series to calculate the  $\beta$  factor(s) as follows:

$$\beta_b = E/8 \text{ for the benchmark GMD event} \quad (4)$$

$$\beta_s = E/12 \text{ for the supplemental GMD event} \quad (5)$$

where  $E$  is the absolute value of peak geoelectric in V/km obtained from the technically justified earth model and the reference geomagnetic field time series.

For large planning areas that span more than one  $\beta$  scaling factor, the most conservative (largest) value for  $\beta$  may be used in determining the peak geoelectric field to obtain conservative results. Alternatively, a planner could perform analysis using a non-uniform or piecewise uniform geoelectric field.

### Applying the Localized Peak Geoelectric Field in the Supplemental GMD Event

The peak geoelectric field of the supplemental GMD event occurs in a localized area.<sup>5</sup> Planners have flexibility to determine how to apply the localized peak geoelectric field over the planning area in performing GIC calculations. Examples of approaches are:

- Apply the peak geoelectric field (12 V/km scaled to the planning area) over the entire planning area;
- Apply a spatially limited (12 V/km scaled to the planning area) peak geoelectric field (e.g., 100 km in North-South latitude direction and 500 km in East-West longitude direction) over a portion(s) of the system, and apply the benchmark GMD event over the rest of the system; or
- Other methods to adjust the benchmark GMD event analysis to account for the localized geoelectric field enhancement of the supplemental GMD event.

---

<sup>4</sup> Available at <http://geomag.usgs.gov/conductivity/>

<sup>5</sup> See the [Supplemental Geomagnetic Disturbance Description white paper located on the Project 2013-03 Geomagnetic Disturbance Mitigation project page: http://www.nerc.com/pa/Stand/Pages/Project-2013-03-Geomagnetic-Disturbance-Mitigation.aspx](http://www.nerc.com/pa/Stand/Pages/Project-2013-03-Geomagnetic-Disturbance-Mitigation.aspx)

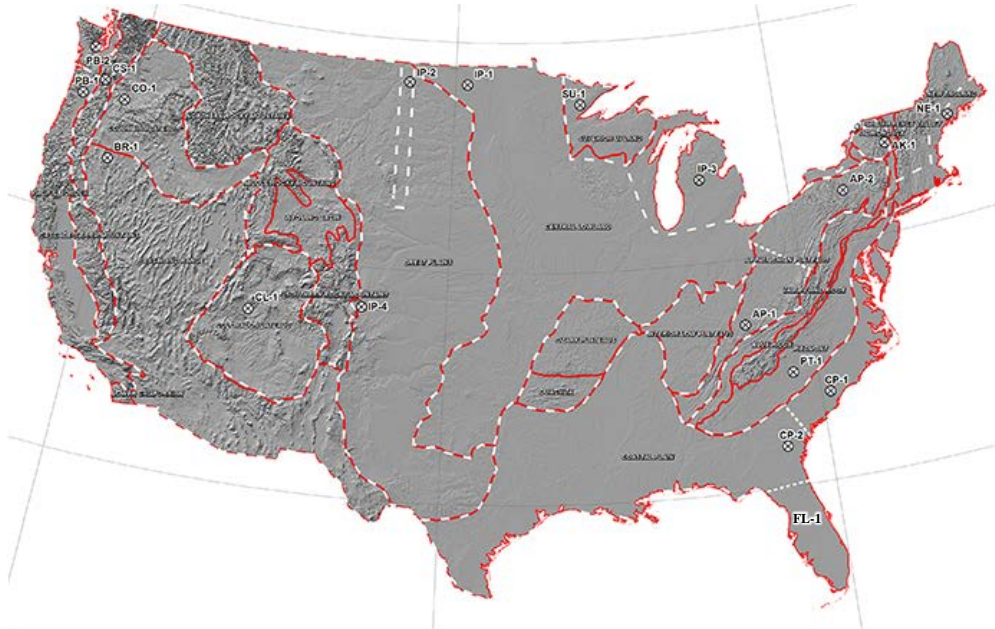


Figure 1: Physiographic Regions of the Continental United States<sup>6</sup>



Figure 2: Physiographic Regions of Canada

<sup>6</sup> Additional map detail is available at the U.S. Geological Survey (<http://geomag.usgs.gov/>)

Table 3 – Geoelectric Field Scaling Factors		
USGS Earth model	Scaling Factor (β) Benchmark Event (β <sub>b</sub> )	Scaling Factor Supplemental Event (β <sub>s</sub> )
AK1A	0.56	<u>0.51</u>
AK1B	0.56	<u>0.51</u>
AP1	0.33	<u>0.30</u>
AP2	0.82	<u>0.78</u>
BR1	0.22	<u>0.22</u>
CL1	0.76	<u>0.73</u>
CO1	0.27	<u>0.25</u>
CP1	0.81	<u>0.77</u>
CP2	0.95	<u>0.86</u>
FL1	<del>0.74</del> <u>0.76</u>	<u>0.73</u>
CS1	0.41	<u>0.37</u>
IP1	0.94	<u>0.90</u>
IP2	0.28	<u>0.25</u>
IP3	0.93	<u>0.90</u>
IP4	0.41	<u>0.35</u>
NE1	0.81	<u>0.77</u>
PB1	0.62	<u>0.55</u>
PB2	0.46	<u>0.39</u>
PT1	1.17	<u>1.19</u>
SL1	0.53	<u>0.49</u>
SU1	0.93	<u>0.90</u>
BOU	0.28	<u>0.24</u>
FBK	0.56	<u>0.56</u>
PRU	0.21	<u>0.22</u>
BC	0.67	<u>0.62</u>
PRAIRIES	0.96	<u>0.88</u>
SHIELD	1.0	<u>1.0</u>
ATLANTIC	0.79	<u>0.76</u>

**Rationale:** Scaling factors in Table 3 are dependent upon the frequency content of the reference storm. Consequently, the benchmark GMD event and the supplemental GMD event may produce different scaling factors for a given earth model.

The scaling factor associated with the benchmark GMD event for the Florida earth model (FL-1) has been updated based on the earth model published on the USGS public website.

Layer Thickness (km)	Resistivity ( $\Omega$ -m)
15	20,000
10	200
125	1,000
200	100
$\infty$	3

Reference Geomagnetic Field Time Series or [Waveshape<sup>7</sup>Waveform for the Benchmark GMD Event<sup>8</sup>](#)

The geomagnetic field measurement record of the March 13-14 1989 GMD event, measured at NRCan's Ottawa geomagnetic observatory is the basis for the reference geomagnetic field [waveshapewaveform](#) to be used to calculate the GIC time series, GIC(t), required for transformer thermal impact assessment.

The geomagnetic latitude of the Ottawa geomagnetic observatory is 55°; therefore, the amplitude of the geomagnetic field measurement data were scaled up to the 60° reference geomagnetic latitude (see Figure 3) such that the resulting peak geoelectric field amplitude computed using the reference earth model was 8 V/km (see Figures 4 and 5). [The Sampling sampling](#) rate for the geomagnetic field [waveshapewaveform](#) is 10 seconds.<sup>9</sup> To use this geoelectric field time series when a different earth model is applicable, it should be scaled with the appropriate [benchmark](#) conductivity scaling factor  $\beta/\beta_b$ .

---

<sup>7</sup> Refer to the [Benchmark GMD Event Description](#) for details on the determination of the reference geomagnetic field waveshape: [http://www.nerc.com/pa/Stand/Pages/Project\\_2013\\_03\\_Geomagnetic\\_Disturbance\\_Mitigation.aspx](http://www.nerc.com/pa/Stand/Pages/Project_2013_03_Geomagnetic_Disturbance_Mitigation.aspx)

<sup>8</sup> Refer to the [Benchmark GMD Event Description white paper](#) for details on the determination of the reference geomagnetic field waveform: <http://www.nerc.com/pa/stand/Pages/TPL0071RI.aspx>

<sup>9</sup> The data file of the benchmark geomagnetic field [waveshapewaveform](#) is available on the [NERC GMD Task Force projectRelated Information](#) page: [http://www.nerc.com/comm/PC/Pages/Geomagnetic\\_Disturbance\\_Task\\_Force\\_\(GMDTF\)\\_2013.aspx](http://www.nerc.com/comm/PC/Pages/Geomagnetic_Disturbance_Task_Force_(GMDTF)_2013.aspx) for TPL-007-1: <http://www.nerc.com/pa/stand/Pages/TPL0071RI.aspx>



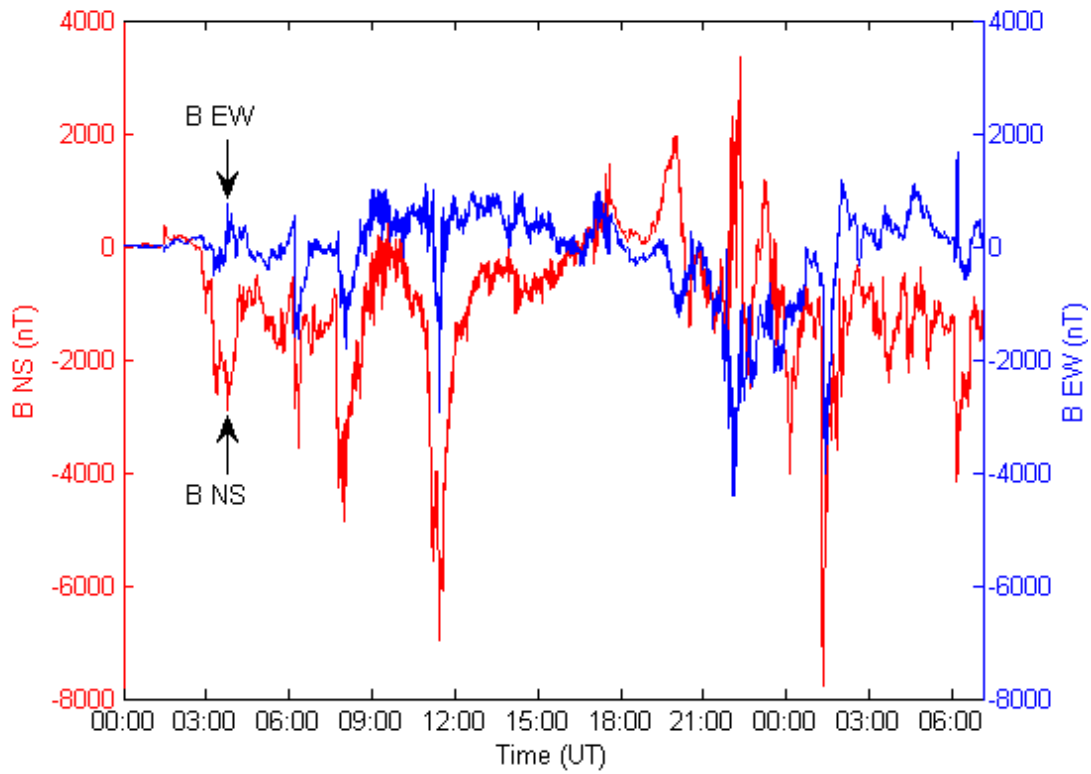


Figure 3: Benchmark Geomagnetic Field [WaveshapeWaveform](#). Red  $B_n$  (Northward), Blue  $B_e$  (Eastward)

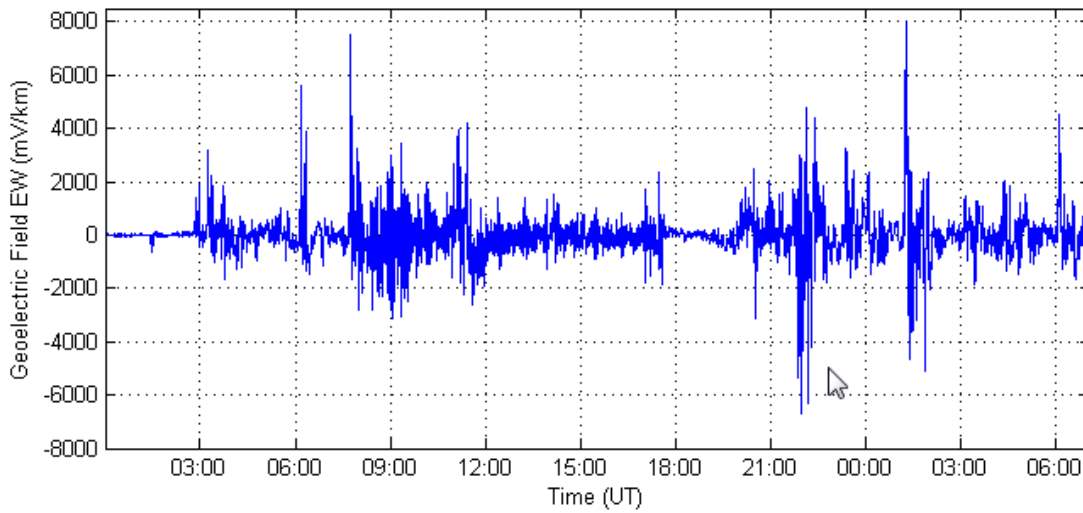


Figure 4: Benchmark Geoelectric Field [WaveshapeWaveform](#) -  $E_E$  (Eastward)

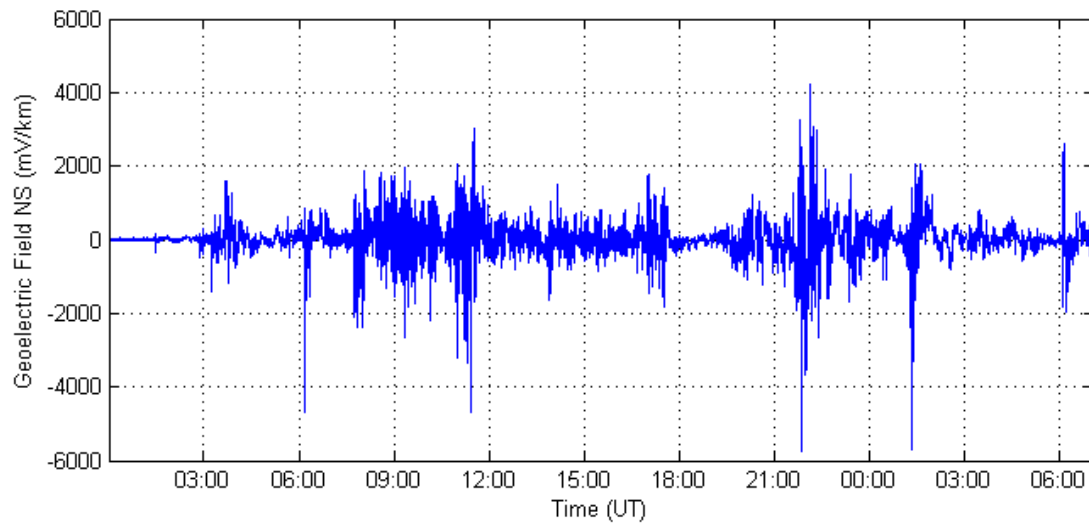


Figure 5: Benchmark Geoelectric Field ~~Waveshape~~Waveform –  $E_N$  (Northward)

### Reference Geomagnetic Field Time Series or Waveform for the Supplemental GMD Event<sup>10</sup>

The geomagnetic field measurement record of the March 13-14, 1989 GMD event, measured at NRCan's Ottawa geomagnetic observatory is the basis for the reference geomagnetic field waveform to be used to calculate the GIC time series, GIC(t), required for transformer thermal impact assessment for the supplemental GMD event. The supplemental GMD event waveform differs from the benchmark GMD event waveform in that the supplemental GMD event waveform has a local enhancement.

The geomagnetic latitude of the Ottawa geomagnetic observatory is 55°; therefore, the amplitude of the geomagnetic field measurement data were scaled up to the 60° reference geomagnetic latitude (see Figure 6) such that the resulting peak geoelectric field amplitude computed using the reference earth model was 12 V/km (see Figure7). The sampling rate for the geomagnetic field waveform is 10 seconds.<sup>11</sup> To use this geoelectric field time series when a different earth model is applicable, it should be scaled with the appropriate supplemental conductivity scaling factor  $\beta_s$ .

---

<sup>10</sup> Refer to the Supplemental GMD Event Description white paper for details on the determination of the reference geomagnetic field waveform: <http://www.nerc.com/pa/Stand/Pages/Project-2013-03-Geomagnetic-Disturbance-Mitigation.aspx>

<sup>11</sup> The data file of the benchmark geomagnetic field waveform is available on the NERC GMD Task Force project page: [http://www.nerc.com/comm/PC/Pages/Geomagnetic-Disturbance-Task-Force-\(GMDTF\)-2013.aspx](http://www.nerc.com/comm/PC/Pages/Geomagnetic-Disturbance-Task-Force-(GMDTF)-2013.aspx)

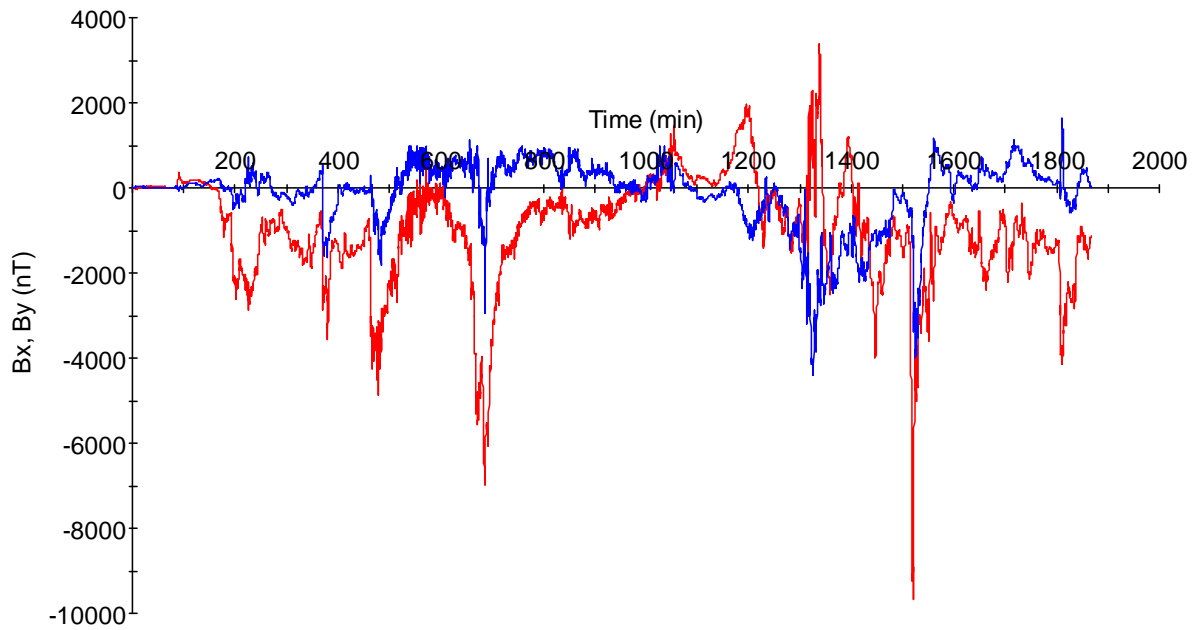


Figure 6: Supplemental Geomagnetic Field Waveform. Red  $B_n$  (Northward), Blue  $B_e$  (Eastward)

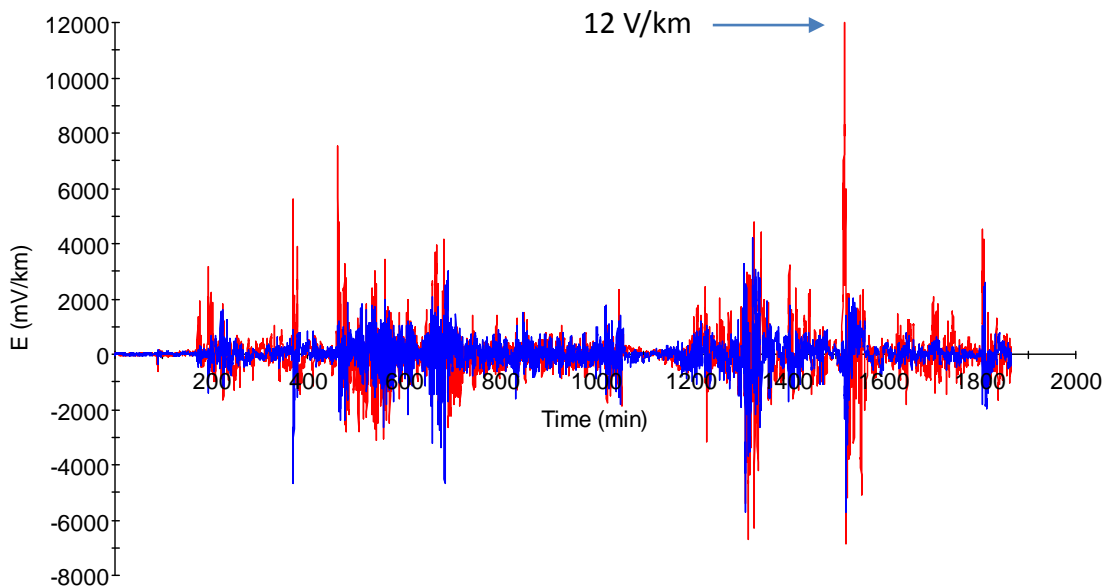


Figure 7: Supplemental Geoelectric Field Waveform. Red  $E_n$  (Northward), Blue  $E_e$  (Eastward)

## C. Compliance

### 1. Compliance Monitoring Process

#### 1.1. Compliance Enforcement Authority

~~As defined in the NERC Rules of Procedure, “Compliance Enforcement Authority” means NERC or the Regional Entity, or any entity as otherwise designated by an Applicable Governmental Authority, in their respective roles of monitoring and/or enforcing compliance with the NERC mandatory and enforceable Reliability Standards in their respective jurisdictions.~~

#### 1.2. Evidence Retention

The following evidence retention ~~periods~~period(s) identify the period of time an entity is required to retain specific evidence to demonstrate compliance. For instances where the evidence retention period specified below is shorter than the time since the last audit, the ~~CEA~~Compliance Enforcement Authority may ask an entity to provide other evidence to show that it was compliant for the full-time period since the last audit.

~~The Planning Coordinator, Transmission Planner, Transmission Owner, and Generator Owner~~The applicable entity shall keep data or evidence to show compliance as identified below unless directed by its Compliance Enforcement Authority to retain specific evidence for a longer period of time as part of an investigation.

- For Requirements R1, R2, R3, R5, R6, R9, and R10, each responsible entity shall retain documentation as evidence for five years.
- For ~~Requirement~~Requirements R4 and R8, each responsible entity shall retain documentation of the current GMD Vulnerability Assessment and the preceding GMD Vulnerability Assessment.
- For Requirement R7, each responsible entity shall retain documentation as evidence for five years or until all actions in the Corrective Action Plan are completed, whichever is later.
- For Requirements R11 and R12, each responsible entity shall retain documentation as evidence for three years.

~~If a Planning Coordinator, Transmission Planner, Transmission Owner, or Generator Owner is found non-compliant it shall keep information related to the non-compliance until mitigation is complete and approved or for the time specified above, whichever is longer.~~

~~The Compliance Enforcement Authority shall keep the last audit records and all requested and submitted subsequent audit records.~~

#### ~~1.3. Compliance Monitoring and Assessment Processes:~~

~~Compliance Audits~~

~~Self-Certifications~~

~~Spot-Checking~~

~~Compliance Investigations~~

~~Self-Reporting~~

~~Complaints~~

~~1.4. Additional Compliance Information~~

~~None~~

- For Requirements R11 and R12, each responsible entity shall retain documentation as evidence for three years.

**1.3. Compliance Monitoring and Assessment Processes:** As defined in the NERC Rules of Procedure, “Compliance Monitoring and Enforcement Program” refers to the identification of the processes that will be used to evaluate data or information for the purpose of assessing performance or outcomes with the associated Reliability Standard.

Table of Compliance Elements

R #	Time Horizon	VRF	Violation Severity Levels			
			Lower VSL	Moderate VSL	High VSL	Severe VSL
R1	Long-term Planning	Lower	N/A	N/A	N/A	The Planning Coordinator, in conjunction with its Transmission Planner(s), failed to determine and identify individual or joint responsibilities of the Planning Coordinator and Transmission Planner(s) in the Planning Coordinator’s planning area for maintaining models and performing the study or studies needed to complete <u>benchmark and supplemental</u> GMD Vulnerability Assessment(s), and <u>implementing process(es) to obtain</u>



TPL-007-12 — Transmission System Planned Performance for Geomagnetic Disturbance Events

						<a href="#">GMD measurement data as specified in this standard.</a>
R2	<a href="#">Long-term Planning</a>	<del>High</del>	N/A	N/A	The responsible entity did not maintain either System models or GIC System models of the responsible entity's planning area for performing the study or studies needed to complete <a href="#">benchmark and supplemental</a> GMD Vulnerability Assessment(s).	The responsible entity did not maintain both System models and GIC System models of the responsible entity's planning area for performing the study or studies needed to complete <a href="#">benchmark and supplemental</a> GMD Vulnerability Assessment(s).
R3	<a href="#">Long-term Planning</a>	<del>Medium</del>	N/A	N/A	N/A	The responsible entity did not have criteria for acceptable System steady state voltage performance for its System during the <del>benchmark</del> GMD <del>event</del> events described in Attachment 1 as required.
R4	<a href="#">Long-term Planning</a>	<del>High</del>	The responsible entity completed a <a href="#">benchmark</a> GMD	The responsible entity's completed <a href="#">benchmark</a> GMD	The responsible entity's completed <a href="#">benchmark</a> GMD	The responsible entity's completed <a href="#">benchmark</a> GMD

			<p>Vulnerability Assessment, but it was more than 60 calendar months and less than or equal to 64 calendar months since the last <a href="#">benchmark</a> GMD Vulnerability Assessment.</p>	<p>Vulnerability Assessment failed to satisfy one of elements listed in Requirement R4, Parts 4.1 through 4.3; OR The responsible entity completed a <a href="#">benchmark</a> GMD Vulnerability Assessment, but it was more than 64 calendar months and less than or equal to 68 calendar months since the last <a href="#">benchmark</a> GMD Vulnerability Assessment.</p>	<p>Vulnerability Assessment failed to satisfy two of the elements listed in Requirement R4, Parts 4.1 through 4.3; OR The responsible entity completed a <a href="#">benchmark</a> GMD Vulnerability Assessment, but it was more than 68 calendar months and less than or equal to 72 calendar months since the last <a href="#">benchmark</a> GMD Vulnerability Assessment.</p>	<p>Vulnerability Assessment failed to satisfy three of the elements listed in Requirement R4, Parts 4.1 through 4.3; OR The responsible entity completed a <a href="#">benchmark</a> GMD Vulnerability Assessment, but it was more than 72 calendar months since the last <a href="#">benchmark</a> GMD Vulnerability Assessment; OR The responsible entity does not have a completed <a href="#">benchmark</a> GMD Vulnerability Assessment.</p>
R5	Long-term Planning	Medium	<p>The responsible entity provided the effective GIC time series, GIC(t), in response to written request, but did so more than 90 calendar days and less than or</p>	<p>The responsible entity provided the effective GIC time series, GIC(t), in response to written request, but did so more than 100 calendar days and less</p>	<p>The responsible entity provided the effective GIC time series, GIC(t), in response to written request, but did so more than 110 calendar days after</p>	<p>The responsible entity did not provide the maximum effective GIC value to the Transmission Owner and Generator Owner that owns each</p>

TPL-007-12 — Transmission System Planned Performance for Geomagnetic Disturbance Events

			equal to 100 calendar days after receipt of a written request.	than or equal to 110 calendar days after receipt of a written request.	receipt of a written request.	applicable BES power transformer in the planning area; OR The responsible entity did not provide the effective GIC time series, GIC(t), upon written request.
R6	Long-term Planning	Medium	The responsible entity failed to conduct a <a href="#">benchmark</a> thermal impact assessment for 5% or less or one of its solely owned and jointly owned applicable BES power transformers (whichever is greater) where the maximum effective GIC value provided in Requirement R5, Part 5.1, is 75 A or greater per phase; OR The responsible entity conducted a <a href="#">benchmark</a> thermal impact assessment for	The responsible entity failed to conduct a <a href="#">benchmark</a> thermal impact assessment for more than 5% up to (and including) 10% or two of its solely owned and jointly owned applicable BES power transformers (whichever is greater) where the maximum effective GIC value provided in Requirement R5, Part 5.1, is 75 A or greater per phase; OR The responsible entity conducted a <a href="#">benchmark</a> thermal	The responsible entity failed to conduct a <a href="#">benchmark</a> thermal impact assessment for more than 10% up to (and including) 15% or three of its solely owned and jointly owned applicable BES power transformers (whichever is greater) where the maximum effective GIC value provided in Requirement R5, Part 5.1, is 75 A or greater per phase; OR The responsible entity conducted a <a href="#">benchmark</a> thermal	The responsible entity failed to conduct a <a href="#">benchmark</a> thermal impact assessment for more than 15% or more than three of its solely owned and jointly owned applicable BES power transformers (whichever is greater) where the maximum effective GIC value provided in Requirement R5, Part 5.1, is 75 A or greater per phase; OR The responsible entity conducted a <a href="#">benchmark</a> thermal

			<p>its solely owned and jointly owned applicable BES power transformers where the maximum effective GIC value provided in Requirement R5, Part 5.1, is 75 A or greater per phase but did so more than 24 calendar months and less than or equal to 26 calendar months of receiving GIC flow information specified in Requirement R5, Part 5.1.</p>	<p>impact assessment for its solely owned and jointly owned applicable BES power transformers where the maximum effective GIC value provided in Requirement R5, Part 5.1, is 75 A or greater per phase but did so more than 26 calendar months and less than or equal to 28 calendar months of receiving GIC flow information specified in Requirement R5, Part 5.1; OR The responsible entity failed to include one of the required elements as listed in Requirement R6, Parts 6.1 through 6.3.</p>	<p>impact assessment for its solely owned and jointly owned applicable BES power transformers where the maximum effective GIC value provided in Requirement R5, Part 5.1, is 75 A or greater per phase but did so more than 28 calendar months and less than or equal to 30 calendar months of receiving GIC flow information specified in Requirement R5, Part 5.1; OR The responsible entity failed to include two of the required elements as listed in Requirement R6, Parts 6.1 through 6.3.</p>	<p>impact assessment for its solely owned and jointly owned applicable BES power transformers where the maximum effective GIC value provided in Requirement R5, Part 5.1, is 75 A or greater per phase but did so more than 30 calendar months of receiving GIC flow information specified in Requirement R5, Part 5.1; OR The responsible entity failed to include three of the required elements as listed in Requirement R6, Parts 6.1 through 6.3.</p>
<a href="#">R7</a>			<p><a href="#">The responsible entity's Corrective Action Plan failed to comply with one of the elements in</a></p>	<p><a href="#">The responsible entity's Corrective Action Plan failed to comply with two of the elements in</a></p>	<p><a href="#">The responsible entity's Corrective Action Plan failed to comply with three of the elements in</a></p>	<p><a href="#">The responsible entity's Corrective Action Plan failed to comply with four or more of the elements</a></p>

			<a href="#">Requirement R7, Parts 7.1 through 7.5.</a>	<a href="#">Requirement R7, Parts 7.1 through 7.5.</a>	<a href="#">Requirement R7, Parts 7.1 through 7.5.</a>	<a href="#">in Requirement R7, Parts 7.1 through 7.5;</a> <a href="#">OR</a> <a href="#">The responsible entity did not have a Corrective Action Plan as required by Requirement R7.</a>
<a href="#">R8</a>			<a href="#">The responsible entity completed a supplemental GMD Vulnerability Assessment, but it was more than 60 calendar months and less than or equal to 64 calendar months since the last supplemental GMD Vulnerability Assessment;</a> <a href="#">OR</a> <a href="#">The responsible entity's completed supplemental GMD Vulnerability Assessment failed to satisfy one of elements listed in Requirement R8, Parts 8.1 through 8.4;</a>	<a href="#">The responsible entity's completed supplemental GMD Vulnerability Assessment failed to satisfy two of elements listed in Requirement R8, Parts 8.1 through 8.4;</a> <a href="#">OR</a> <a href="#">The responsible entity completed a supplemental GMD Vulnerability Assessment, but it was more than 64 calendar months and less than or equal to 68 calendar months since the last supplemental GMD</a>	<a href="#">The responsible entity's completed supplemental GMD Vulnerability Assessment failed to satisfy three of the elements listed in Requirement R8, Parts 8.1 through 8.4;</a> <a href="#">OR</a> <a href="#">The responsible entity completed a supplemental GMD Vulnerability Assessment, but it was more than 68 calendar months and less than or equal to 72 calendar months since the last supplemental GMD Vulnerability Assessment.</a>	<a href="#">The responsible entity's completed supplemental GMD Vulnerability Assessment failed to satisfy four of the elements listed in Requirement R8, Parts 8.1 through 8.4;</a> <a href="#">OR</a> <a href="#">The responsible entity completed a supplemental GMD Vulnerability Assessment, but it was more than 72 calendar months since the last supplemental GMD Vulnerability Assessment;</a> <a href="#">OR</a>

				<a href="#">Vulnerability Assessment.</a>		<a href="#">The responsible entity does not have a completed supplemental GMD Vulnerability Assessment.</a>
<a href="#">R9</a>			<a href="#">The responsible entity provided the effective GIC time series, GIC(t), in response to written request, but did so more than 90 calendar days and less than or equal to 100 calendar days after receipt of a written request.</a>	<a href="#">The responsible entity provided the effective GIC time series, GIC(t), in response to written request, but did so more than 100 calendar days and less than or equal to 110 calendar days after receipt of a written request.</a>	<a href="#">The responsible entity provided the effective GIC time series, GIC(t), in response to written request, but did so more than 110 calendar days after receipt of a written request.</a>	<a href="#">The responsible entity did not provide the maximum effective GIC value to the Transmission Owner and Generator Owner that owns each applicable BES power transformer in the planning area; OR The responsible entity did not provide the effective GIC time series, GIC(t), upon written request.</a>
<a href="#">R10</a>			<a href="#">The responsible entity failed to conduct a supplemental thermal impact assessment for 5% or less or one of its solely owned and jointly owned applicable BES power</a>	<a href="#">The responsible entity failed to conduct a supplemental thermal impact assessment for more than 5% up to (and including) 10% or two of its solely owned and jointly</a>	<a href="#">The responsible entity failed to conduct a supplemental thermal impact assessment for more than 10% up to (and including) 15% or three of its solely owned and jointly</a>	<a href="#">The responsible entity failed to conduct a supplemental thermal impact assessment for more than 15% or more than <b>three of its</b> solely owned and jointly owned</a>

			<p><u>transformers (whichever is greater) where the maximum effective GIC value provided in Requirement R9, Part 9.1, is 85 A or greater per phase;</u>  <u>OR</u>  <u>The responsible entity conducted a supplemental thermal impact assessment for its solely owned and jointly owned applicable BES power transformers where the maximum effective GIC value provided in Requirement R9, Part 9.1, is 85 A or greater per phase but did so more than 24 calendar months and less than or equal to 26 calendar months of receiving GIC flow information specified in Requirement R9, Part 9.1.</u></p>	<p><u>owned applicable BES power transformers (whichever is greater) where the maximum effective GIC value provided in Requirement R9, Part 9.1, is 85 A or greater per phase;</u>  <u>OR</u>  <u>The responsible entity conducted a supplemental thermal impact assessment for its solely owned and jointly owned applicable BES power transformers where the maximum effective GIC value provided in Requirement R9, Part 9.1, is 85 A or greater per phase but did so more than 26 calendar months and less than or equal to 28 calendar months of receiving GIC flow information specified</u></p>	<p><u>owned applicable BES power transformers (whichever is greater) where the maximum effective GIC value provided in Requirement R9, Part 9.1, is 85 A or greater per phase;</u>  <u>OR</u>  <u>The responsible entity conducted a supplemental thermal impact assessment for its solely owned and jointly owned applicable BES power transformers where the maximum effective GIC value provided in Requirement R9, Part 9.1, is 85 A or greater per phase but did so more than 28 calendar months and less than or equal to 30 calendar months of receiving GIC flow information specified</u></p>	<p><u>applicable BES power transformers (whichever is greater) where <b>the</b> maximum effective GIC value provided <b>in Requirement R9, Part 9.1</b>, is 85 A or greater per phase;</u>  <u>OR</u>  <u>The responsible entity conducted a supplemental thermal impact assessment for its solely owned and jointly owned applicable BES power transformers where the maximum effective GIC value provided in Requirement R9, Part 9.1, is 85 A or greater per phase but did so more than 30 calendar months of receiving GIC flow information specified in Requirement R9, Part 9.1;</u>  <u>OR</u></p>
--	--	--	--	--	--	---

TPL-007-42 — Transmission System Planned Performance for Geomagnetic Disturbance Events

				<p><a href="#">in Requirement R9, Part 9.1;</a>  <a href="#">OR</a>  <a href="#">The responsible entity failed to include <u>one</u> of the required elements as listed in Requirement R10, Parts 10.1 through 10.3.</a></p>	<p><a href="#">in Requirement R9, Part 9.1;</a>  <a href="#">OR</a>  <a href="#">The responsible entity failed to include <u>two</u> of the required elements as listed in Requirement R10, Parts 10.1 through 10.3.</a></p>	<p><a href="#">The responsible entity failed to include three of the required elements as listed in Requirement R10, Parts 10.1 through 10.3.</a></p>
<a href="#">R11</a>			<a href="#">N/A</a>	<a href="#">N/A</a>	<a href="#">N/A</a>	<p><a href="#">The responsible entity did not implement a process to obtain GIC monitor data from at least one GIC monitor located in the Planning Coordinator’s planning area or other part of the system included in the Planning Coordinator’s GIC System Model.</a></p>
<a href="#">R12</a>			<a href="#">N/A</a>	<a href="#">N/A</a>	<a href="#">N/A</a>	<p><a href="#">The responsible entity did not implement a process to obtain geomagnetic field data for its Planning Coordinator’s planning area.</a></p>





**D. Regional Variances**

None.

**E. Interpretations**

None.

**F. Associated Documents**

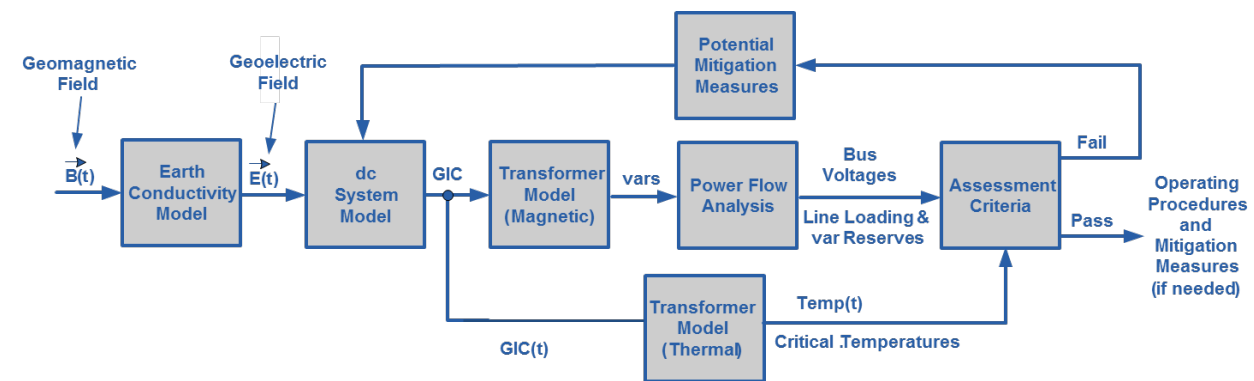
None.

**Version History**

Version	Date	Action	Change Tracking
1	December 17, 2014	Adopted by the NERC Board of Trustees	
<u>2</u>	<u>TBD</u>	<u>Revised to respond to directives in FERC Order No. 830.</u>	<u>Revised</u>

### Guidelines and Technical Basis

The diagram below provides an overall view of the GMD Vulnerability Assessment process:



The requirements in this standard cover various aspects of the GMD Vulnerability Assessment process.

#### Benchmark GMD Event (Attachment 1)

The benchmark GMD event defines the geoelectric field values used to compute GIC flows that are needed to conduct a [benchmark](#) GMD Vulnerability Assessment. A white paper that includes the event description, analysis, and example calculations is available on the Project 2013-03 Geomagnetic Disturbance Mitigation project page [at](#):

<http://www.nerc.com/pa/Stand/Pages/Project-2013-03-Geomagnetic-Disturbance-Mitigation.aspx>  
<http://www.nerc.com/pa/stand/Pages/TPL0071RI.aspx>

#### Supplemental GMD Event (Attachment 1)

The supplemental GMD event defines the geoelectric field values used to compute GIC flows that are needed to conduct a supplemental GMD Vulnerability Assessment. A white paper that includes the event description and analysis is available on the Project 2013-03 Geomagnetic Disturbance Mitigation project page:

<http://www.nerc.com/pa/Stand/Pages/Project-2013-03-Geomagnetic-Disturbance-Mitigation.aspx>

#### Requirement R2

A GMD Vulnerability Assessment requires a GIC System model, which is a dc representation of the System, to calculate GIC flow. In a GMD Vulnerability Assessment, GIC simulations are used to determine transformer Reactive Power absorption and transformer thermal response. Details for developing the GIC System model are provided in the NERC GMD Task Force guide: *Application Guide for Computing Geomagnetically-Induced Current in the Bulk Power System*. The guide is available at:

[http://www.nerc.com/comm/PC/Geomagnetic%20Disturbance%20Task%20Force%20GMDTF%202013/GIC%20Application%20Guide%202013\\_approved.pdf](http://www.nerc.com/comm/PC/Geomagnetic%20Disturbance%20Task%20Force%20GMDTF%202013/GIC%20Application%20Guide%202013_approved.pdf)

## Application Guidelines

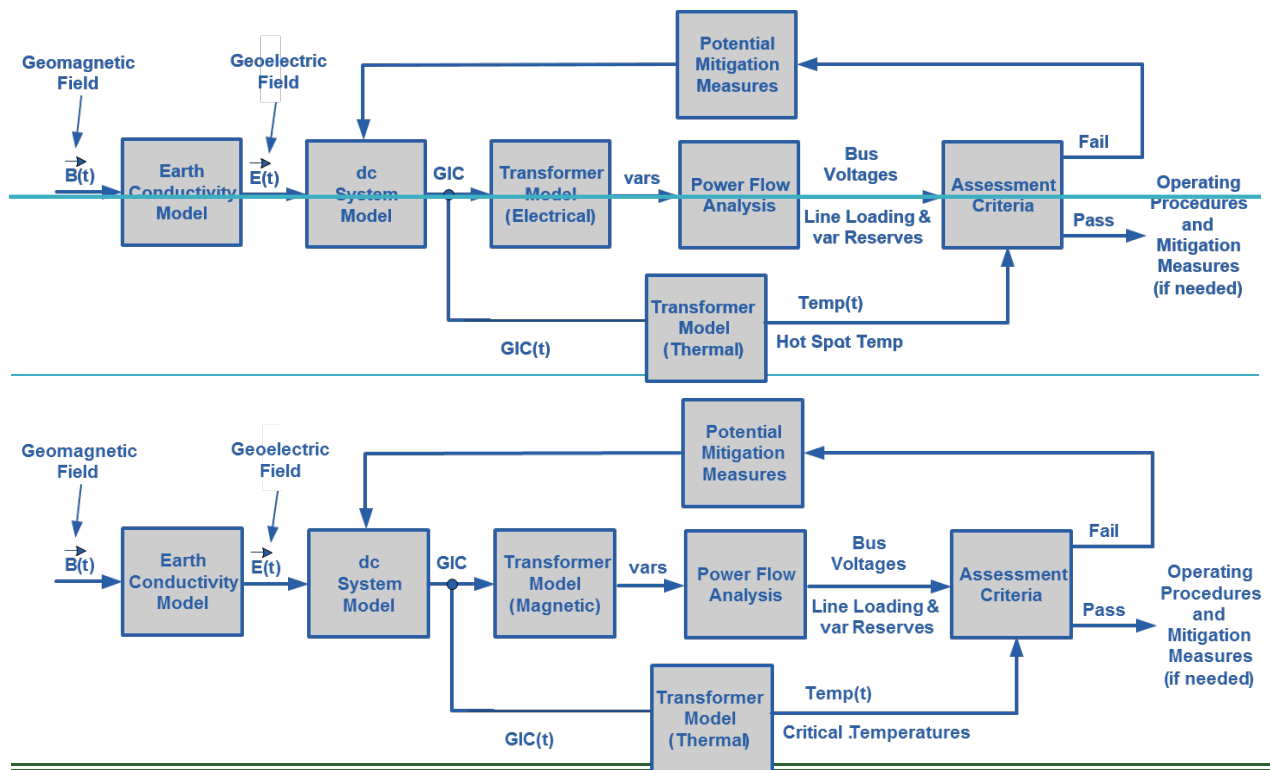
Underground pipe-type cables present a special modeling situation in that the steel pipe that encloses the power conductors significantly reduces the geoelectric field induced into the conductors themselves, while they remain a path for GIC. Solid dielectric cables that are not enclosed by a steel pipe will not experience a reduction in the induced geoelectric field. A planning entity should account for special modeling situations in the GIC system model, if applicable.

### Requirement R4

The *GMD Planning Guide* developed by the NERC GMD Task Force provides technical information on GMD-specific considerations for planning studies. It is available at:

[http://www.nerc.com/comm/PC/Geomagnetic%20Disturbance%20Task%20Force%20GMDTF%202013/GMD%20Planning%20Guide\\_approved.pdf](http://www.nerc.com/comm/PC/Geomagnetic%20Disturbance%20Task%20Force%20GMDTF%202013/GMD%20Planning%20Guide_approved.pdf)

The diagram below provides an overall view of the GMD Vulnerability Assessment process:



### Requirement R5

The [transformer benchmark](#) thermal impact assessment [of transformers](#) specified in Requirement R6 is based on GIC information for the [benchmark benchmark](#) GMD Event. This GIC information is determined by the planning entity through simulation of the GIC System model and must be provided to the entity responsible for conducting the thermal impact assessment. GIC information should be provided in accordance with Requirement R5 each time the GMD Vulnerability Assessment is performed since, by definition, the GMD Vulnerability Assessment includes a documented evaluation of susceptibility to localized equipment damage due to GMD.

## Application Guidelines

---

The maximum effective GIC value provided in Part 5.1 is used for ~~transformer~~the benchmark thermal impact assessment. Only those transformers that experience an effective GIC value of 75 A or greater per phase require evaluation in Requirement R6.

GIC(t) provided in Part 5.2 is used to convert the steady -state GIC flows to time-series GIC data for ~~transformer~~the benchmark thermal impact assessment of transformers. This information may be needed by one or more of the methods for performing a benchmark thermal impact assessment. Additional information is in the following section and the thermal impact assessment white paper.

The peak GIC value of 75 Amps per phase has been shown through thermal modeling to be a conservative threshold below which the risk of exceeding known temperature limits established by technical organizations is low.

### **Requirement R6**

The benchmark thermal impact assessment of a power transformer may be based on manufacturer-provided GIC capability curves, thermal response simulation, thermal impact screening, or other technically justified means. Approaches for conducting the assessment are presented in the *Transformer Thermal Impact Assessment* white paper ~~posted on the project page~~. The ERO enterprise has endorsed the white paper as Implementation Guidance for this requirement. The white paper is posted on the NERC compliance guidance page:  
<http://www.nerc.com/pa/Stand/Pages/Project-2013-03-Geomagnetic-Disturbance-Mitigation.aspx>

<http://www.nerc.com/pa/comp/guidance/Pages/default.aspx>

Transformers are exempt from the benchmark thermal impact assessment requirement if the effective GIC value for the transformer is less than 75 A per phase, as determined by a GIC analysis of the System. Justification for this criterion is provided in the *Screening Criterion for Transformer Thermal Impact Assessment* white paper posted on the Related Information page for project TPL-007-1. A documented design specification exceeding this value is also a justifiable threshold criterion that exempts a transformer from Requirement R6.

The benchmark threshold criteria and its associated transformer thermal impact must be evaluated on the basis of effective GIC. Refer to the white papers for additional information.

### **Requirement R7**

Technical considerations for GMD mitigation planning, including operating and equipment strategies, are available in Chapter 5 of the *GMD Planning Guide*. Additional information is available in the *2012 Special Reliability Assessment Interim Report: Effects of Geomagnetic Disturbances on the Bulk-Power System*:  
<http://www.nerc.com/pa/RAPA/ra/Reliability%20Assessments%20DL/2012GMD.pdf>

### **Requirement R8**

## Application Guidelines

---

The *GMD Planning Guide* developed by the NERC GMD Task Force provides technical information on GMD-specific considerations for planning studies. It is available at: [http://www.nerc.com/comm/PC/Geomagnetic%20Disturbance%20Task%20Force%20GMDTF%202013/GMD%20Planning%20Guide\\_approved.pdf](http://www.nerc.com/comm/PC/Geomagnetic%20Disturbance%20Task%20Force%20GMDTF%202013/GMD%20Planning%20Guide_approved.pdf)

The supplemental GMD Vulnerability Assessment process is similar to the benchmark GMD Vulnerability Assessment process described under Requirement R4.

### **Requirement R9**

The supplemental thermal impact assessment specified of transformers in Requirement R10 is based on GIC information for the supplemental GMD Event. This GIC information is determined by the planning entity through simulation of the GIC System model and must be provided to the entity responsible for conducting the thermal impact assessment. GIC information should be provided in accordance with Requirement R9 each time the GMD Vulnerability Assessment is performed since, by definition, the GMD Vulnerability Assessment includes a documented evaluation of susceptibility to localized equipment damage due to GMD.

The maximum effective GIC value provided in Part 9.1 is used for the supplemental thermal impact assessment. Only those transformers that experience an effective GIC value of 85 A or greater per phase require evaluation in Requirement R10.

GIC(t) provided in Part 9.2 is used to convert the steady state GIC flows to time-series GIC data for the supplemental thermal impact assessment of transformers. This information may be needed by one or more of the methods for performing a supplemental thermal impact assessment. Additional information is in the following section.

The peak GIC value of 85 Amps per phase has been shown through thermal modeling to be a conservative threshold below which the risk of exceeding known temperature limits established by technical organizations is low.

### **Requirement R10**

The supplemental thermal impact assessment of a power transformer may be based on manufacturer-provided GIC capability curves, thermal response simulation, thermal impact screening, or other technically justified means. Approaches for conducting the assessment are presented in the *Transformer Thermal Impact Assessment* white paper discussed in the Requirement R6 section above. A revised version of the *Transformer Thermal Impact Assessment* white paper has been developed to include updated information pertinent to the supplemental GMD event and supplemental thermal impact assessment. This revised white paper is posted on the project page at:

<http://www.nerc.com/pa/Stand/Pages/Project-2013-03-Geomagnetic-Disturbance-Mitigation.aspx>

Transformers are exempt from the supplemental thermal impact assessment requirement if the effective GIC value for the transformer is less than 85 A per phase, as determined by a GIC analysis of the System. Justification for this criterion is provided in the revised *Screening*

## Application Guidelines

---

Criterion for Transformer Thermal Impact Assessment white paper posted on the project page. A documented design specification exceeding this value is also a justifiable threshold criterion that exempts a transformer from Requirement R10.

The supplemental threshold criteria and its associated transformer thermal impact must be evaluated on the basis of effective GIC. Refer to the white papers for additional information.

### Requirement R11

Technical considerations for GIC monitoring are contained in the NERC 2012 GMD Report (see Chapter 6). GIC monitoring is generally performed by Hall effect transducers that are attached to the neutral of the wye-grounded transformer. Data from GIC monitors is useful model validation and situational awareness.

Responsible entities consider the following in developing a process for obtaining GIC monitor data:

- **Monitor locations.** An entity's operating process may be constrained by location of existing GIC monitors. However, when planning for additional GIC monitoring installations consider that data from monitors located in areas found to have high GIC based on system studies may provide more useful information for validation and situational awareness purposes. Conversely, data from GIC monitors that are located in the vicinity of transportation systems using direct current (e.g., subways or light rail) may be unreliable.
- **Monitor specifications.** Capabilities of Hall effect transducers, existing and planned, should be considered in the operating process. When planning new GIC monitor installations, consider monitor data range (e.g., -500 A through + 500 A) and ambient temperature ratings consistent with temperatures in the region in which the monitor will be installed.
- **Sampling Interval.** An entity's operating process may be constrained by capabilities of existing GIC monitors. However, when possible specify data sampling during periods of interest at a rate of 10 seconds or faster.
- **Collection Periods.** The process should specify when the entity expects GIC data to be collected. For example, collection could be required during periods where the Kp index is above a threshold, or when GIC values are above a threshold. Determining when to discontinue collecting GIC data should also be specified to maintain consistency in data collection.
- **Data format.** Specify time and value formats. For example, Greenwich Mean Time (GMT) (MM/DD/YYYY HH:MM:SS) and GIC Value (Ampere). Positive (+) and negative (-) signs indicate direction of GIC flow. Positive reference is flow from ground into transformer neutral. Time fields should indicate the sampled time rather than system or SCADA time if **supported by the** GIC monitor system.
- **Data retention.** The entity's process should specify data retention periods, for example 1 year. Data retention periods should be adequately long to support availability for the entity's model validation process and external reporting requirements, if any.

## Application Guidelines

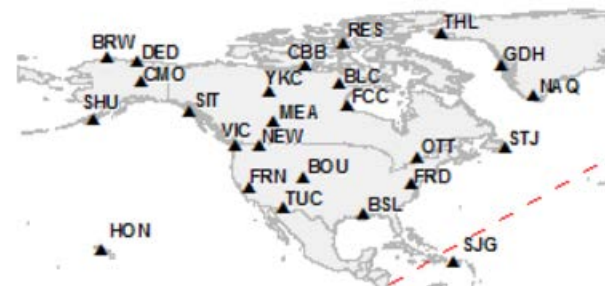
---

- Additional information. The entity's process should specify collection of other information necessary for making the data useful, for example monitor location and type of neutral connection (e.g., three-phase or single-phase).

### Requirement R12

Magnetometers measure changes in the earth's magnetic field. Entities should obtain data from the nearest accessible magnetometer. Sources of magnetometer data include:

- Observatories such as those operated by U.S. Geological Survey and Natural Resources Canada, see figure below for locations (<http://www.intermagnet.org/>):



- Research institutions and academic universities;
- Entities with installed magnetometers.

Entities that choose to install magnetometers should consider equipment specifications and data format protocols contained in the latest version of the Intermagnet Technical Reference Manual, which is available at:

[http://www.intermagnet.org/publications/intermag\\_4-6.pdf](http://www.intermagnet.org/publications/intermag_4-6.pdf)



### **Rationale:**

During development of ~~this standard~~ [TPL-007-1](#), text boxes were embedded within the standard to explain the rationale for various parts of the standard. ~~Upon BOT approval, the~~ [The](#) text from the rationale text boxes was moved to this section. ~~upon approval of TPL-007-1 by the NERC Board of Trustees. In developing TPL-007-2, the SDT has made changes to the sections below only when necessary for clarity. Changes are marked with brackets [ ]~~.

### **Rationale for Applicability:**

Instrumentation transformers and station service transformers do not have significant impact on geomagnetically-induced current (GIC) flows; therefore, these transformers are not included in the applicability for this standard.

Terminal voltage describes line-to-line voltage.

### **Rationale for R1:**

In some areas, planning entities may determine that the most effective approach to conduct a GMD Vulnerability Assessment is through a regional planning organization. No requirement in the standard is intended to prohibit a collaborative approach where roles and responsibilities are determined by a planning organization made up of one or more Planning Coordinator(s).

### **Rationale for R2:**

A GMD Vulnerability Assessment requires a GIC System model to calculate GIC flow which is used to determine transformer Reactive Power absorption and transformer thermal response. Guidance for developing the GIC System model is provided in the GIC Application Guide developed by the NERC GMD Task Force and available at:

[http://www.nerc.com/comm/PC/Geomagnetic%20Disturbance%20Task%20Force%20GMDTF%202013/GIC%20Application%20Guide%202013\\_approved.pdf](http://www.nerc.com/comm/PC/Geomagnetic%20Disturbance%20Task%20Force%20GMDTF%202013/GIC%20Application%20Guide%202013_approved.pdf)

The System model specified in Requirement R2 is used in conducting steady state power flow analysis that accounts for the Reactive Power absorption of power transformer(s) due to GIC in the System.

The GIC System model includes all power transformer(s) with a high side, wye-grounded winding with terminal voltage greater than 200 kV. The model is used to calculate GIC flow in the network.

The projected System condition for GMD planning may include adjustments to the System that are executable in response to space weather information. These adjustments could include, for example, recalling or postponing maintenance outages.

The Violation Risk Factor (VRF) for Requirement R2 is changed from Medium to High. This change is for consistency with the VRF for approved standard TPL-001-4 Requirement R1, which is proposed for revision in the NERC filing dated August 29, 2014 (RM12-1-000). NERC guidelines require consistency among Reliability Standards.

### **Rationale for R3:**

Requirement R3 allows a responsible entity the flexibility to determine the System steady state voltage criteria for System steady state performance in Table 1. Steady state voltage limits are an example of System steady state performance criteria.

### **Rationale for R4:**

The GMD Vulnerability Assessment includes steady state power flow analysis and the supporting study or studies using the models specified in Requirement R2 that account for the effects of GIC. Performance criteria are specified in Table 1.

At least one System On-Peak Load and at least one System Off-Peak Load must be examined in the analysis.

Distribution of GMD Vulnerability Assessment results provides a means for sharing relevant information with other entities responsible for planning reliability. Results of GIC studies may affect neighboring systems and should be taken into account by planners.

The GMD Planning Guide developed by the NERC GMD Task Force provides technical information on GMD-specific considerations for planning studies. It is available at:

[http://www.nerc.com/comm/PC/Geomagnetic%20Disturbance%20Task%20Force%20GMDTF%202013/GMD%20Planning%20Guide\\_approved.pdf](http://www.nerc.com/comm/PC/Geomagnetic%20Disturbance%20Task%20Force%20GMDTF%202013/GMD%20Planning%20Guide_approved.pdf)

The provision of information in Requirement R4, Part 4.3, shall be subject to the legal and regulatory obligations for the disclosure of confidential and/or sensitive information.

### **Rationale for R5:**

This GIC information is necessary for determining the thermal impact of GIC on transformers in the planning area and must be provided to entities responsible for performing the thermal impact assessment so that they can accurately perform the assessment. GIC information should be provided in accordance with Requirement R5 as part of the GMD Vulnerability Assessment process since, by definition, the GMD Vulnerability Assessment includes documented evaluation of susceptibility to localized equipment damage due to GMD.

The maximum effective GIC value provided in Part 5.1 is used for transformer thermal impact assessment.

GIC(t) provided in Part 5.2 can alternatively be used to convert the steady -state GIC flows to time-series GIC data for transformer thermal impact assessment. This information may be needed by one or more of the methods for performing a thermal impact assessment. Additional guidance is available in the Transformer Thermal Impact Assessment white paper:

<http://www.nerc.com/pa/Stand/Pages/Project-2013-03-Geomagnetic-Disturbance-Mitigation.aspx>

[<http://www.nerc.com/pa/comp/guidance/Pages/default.aspx>]

A Transmission Owner or Generator Owner that desires GIC(t) may request it from the planning entity. The planning entity shall provide GIC(t) upon request once GIC has been calculated, but no later than 90 calendar days after receipt of a request from the owner and after completion of Requirement R5, Part 5.1.

The provision of information in Requirement R5 shall be subject to the legal and regulatory obligations for the disclosure of confidential and/or sensitive information.

### **Rationale for R6:**

## Application Guidelines

---

The transformer thermal impact screening criterion has been revised from 15 A per phase to 75 A per phase- [\[for the benchmark GMD event\]](#). Only those transformers that experience an effective GIC value of 75 A per phase or greater require evaluation in Requirement R6. The justification is provided in the Thermal Screening Criterion white paper.

The thermal impact assessment may be based on manufacturer-provided GIC capability curves, thermal response simulation, thermal impact screening, or other technically justified means. The transformer thermal assessment will be repeated or reviewed using previous assessment results each time the planning entity performs a GMD Vulnerability Assessment and provides GIC information as specified in Requirement R5. Approaches for conducting the assessment are presented in the Transformer Thermal Impact Assessment white paper posted on the project page.

<http://www.nerc.com/pa/Stand/Pages/Project-2013-03-Geomagnetic-Disturbance-Mitigation.aspx>

Thermal impact assessments are provided to the planning entity, as determined in Requirement R1, so that identified issues can be included in the GMD Vulnerability Assessment (R4), and the Corrective Action Plan (R7) as necessary.

Thermal impact assessments of non-BES transformers are not required because those transformers do not have a wide-area effect on the reliability of the interconnected Transmission system.

The provision of information in Requirement R6, Part 6.4, shall be subject to the legal and regulatory obligations for the disclosure of confidential and/or sensitive information.

### **Rationale for R7:**

Corrective Action Plans are defined in the NERC Glossary of Terms:

*A list of actions and an associated timetable for implementation to remedy a specific problem.*

Corrective Action Plans must, subject to the vulnerabilities identified in the assessments, contain strategies for protecting against the potential impact of the ~~benchmark~~[\[B\]enchmark](#) GMD event, based on factors such as the age, condition, technical specifications, system configuration, or location of specific equipment. Chapter 5 of the NERC GMD Task Force *GMD Planning Guide* provides a list of mitigating measures that may be appropriate to address an identified performance issue.

The provision of information in Requirement R7, Part 7.3, [\[Part 7.5 in TPL-007-2\]](#), shall be subject to the legal and regulatory obligations for the disclosure of confidential and/or sensitive information.

### **Rationale for Table 3:**

Table 3 has been revised to use the same ground model designation, FL1, as is being used by USGS. The calculated scaling factor for FL1 is 0.74- [\[The scaling factor associated with the benchmark GMD event for the Florida earth model \(FL-1\) has been updated to 0.76 in TPL-007-2 based on the earth model published on the USGS public website.\]](#)

# Implementation Plan

## Project 2013-03 Geomagnetic Disturbance Mitigation Reliability Standard TPL-007-2

### Applicable Standard(s)

- TPL-007-2 - Transmission System Planned Performance for Geomagnetic Disturbance Events

### Requested Retirement(s)

- TPL-007-1 - Transmission System Planned Performance for Geomagnetic Disturbance Events

### Prerequisite Standard(s)

None

### Applicable Entities

- Planning Coordinator with a planning area that includes a Facility or Facilities specified in Section 4.2 of the standard;
- Transmission Planner with a planning area that includes a Facility or Facilities specified in Section 4.2 of the standard;
- Transmission Owner who owns a Facility or Facilities specified in Section 4.2 of the standard;
- Generator Owner who owns a Facility or Facilities specified in Section 4.2 of the standard.

Section 4.2 states that the standard applies to facilities that include power transformer(s) with a high side, wye-grounded winding with terminal voltage greater than 200 kV.

### Terms in the NERC Glossary of Terms

There are no new, modified, or retired terms.

### Background

On September 22, 2016, the Federal Energy Regulatory Commission (FERC) issued Order No. 830 approving Reliability Standard TPL-007-1 and its associated five-year Implementation Plan. In the Order, FERC also directed NERC to develop certain modifications to the standard. FERC established a deadline of 18 months from the effective date of Order No. 830 for completing the revisions, which is May 2018.

### General Considerations

This Implementation Plan is intended to integrate the new requirements in TPL-007-2 with the GMD Vulnerability Assessment process that is being implemented through approved TPL-007-1. At the time of the May 2018 filing deadline, many requirements in approved standard TPL-007-1 that lead to completion of the GMD Vulnerability Assessment will be in effect. Furthermore, many entities

may be taking steps to complete studies or assessments that are required by future enforceable requirements in TPL-007-1. The Implementation Plan phases in the requirements in TPL-007-2 based on the effective date of TPL-007-2, as follows:

- **Effective Date before January 1, 2021.** Implementation timeline supports applicable entities completing new requirements for supplemental GMD Vulnerability Assessments concurrently with requirements for the benchmark GMD Vulnerability Assessment (concurrent effective dates).
- **Effective Date on or after January 1, 2021.** Implementation timeline supports applicable entities completing the benchmark GMD Vulnerability Assessments before new requirements for supplemental GMD Vulnerability Assessments become effective.

### **Effective Date and Phased-In Compliance Dates**

The effective date for the proposed Reliability Standard is provided below. Where the standard drafting team identified the need for a longer implementation period for compliance with a particular section of a proposed Reliability Standard (e.g., an entire Requirement or a portion thereof), the additional time for compliance with that section is specified below. The phased-in compliance date for those particular sections represents the date that entities must begin to comply with that particular section of the Reliability Standard, even where the Reliability Standard goes into effect at an earlier date.

#### **Standard TPL-007-2**

Where approval by an applicable governmental authority is required, the standard shall become effective on the first day of the first calendar quarter that is three (3) months after the effective date of the applicable governmental authority's order approving the standard, or as otherwise provided for by the applicable governmental authority.

Where approval by an applicable governmental authority is not required, the standard shall become effective on the first day of the first calendar quarter that is three (3) months after the date the standard is adopted by the NERC Board of Trustees, or as otherwise provided for in that jurisdiction.

#### ***If TPL-007-2 becomes effective before January 1, 2021***

Implementation timeline supports applicable entities completing new requirements for supplemental GMD Vulnerability Assessments concurrently with requirements for the benchmark GMD Vulnerability Assessment (concurrent effective dates).

#### **Compliance Date for TPL-007-2 Requirement R9**

Entities shall not be required to comply with Requirement R9 until six (6) months after the effective date of Reliability Standard TPL-007-2.

**Compliance Date for TPL-007-2 Requirements R11 and R12**

Entities shall not be required to comply with Requirements R11 and R12 until 24 months after the effective date of Reliability Standard TPL-007-2.

**Compliance Date for TPL-007-2 Requirements R6 and R10**

Entities shall not be required to comply with Requirements R6 and R10 until 30 months after the effective date of Reliability Standard TPL-007-2.

**Compliance Date for TPL-007-2 Requirements R3, R4, and R8**

Entities shall not be required to comply with Requirements R3, R4, and R8 until 42 months after the effective date of Reliability Standard TPL-007-2.

**Compliance Date for TPL-007-2 Requirement R7**

Entities shall not be required to comply with Requirement R7 until 54 months after the effective date of Reliability Standard TPL-007-2.

*If TPL-007-2 becomes effective on or after January 1, 2021*

Implementation timeline supports applicable entities completing the benchmark GMD Vulnerability Assessments before new requirements for supplemental GMD Vulnerability Assessments become effective.

**Compliance Date for TPL-007-2 Requirements R3 and R4**

Entities shall not be required to comply with Requirements R3 and R4 until 12 months after the effective date of Reliability Standard TPL-007-2.

**Compliance Date for TPL-007-2 Requirements R7, R11, and R12**

Entities shall not be required to comply with Requirements R7, R11, and R12 until 24 months after the effective date of Reliability Standard TPL-007-2.

**Compliance Date for TPL-007-2 Requirement R9**

Entities shall not be required to comply with Requirement R9 until 36 months after the effective date of Reliability Standard TPL-007-2.

**Compliance Date for TPL-007-2 Requirement R10**

Entities shall not be required to comply with Requirement R10 until 60 months after the effective date of Reliability Standard TPL-007-2.

**Compliance Date for TPL-007-2 Requirement R8**

Entities shall not be required to comply with Requirement R8 until 72 months after the effective date of Reliability Standard TPL-007-2.

## **Retirement Date**

### **Standard TPL-007-1**

Reliability Standard TPL-007-1 shall be retired immediately prior to the effective date of TPL-007-2 in the particular jurisdiction in which the revised standard is becoming effective.

## **Initial Performance of Periodic Requirements**

Transmission Owners and Generator Owners are not required to comply with Requirement R6 prior to the compliance date for Requirement R6, regardless of when GIC flow information specified in Requirement R5 Part 5.1 is received.

Transmission Owners and Generator Owners are not required to comply with Requirement R10 prior to the compliance date for Requirement R10, regardless of when GIC flow information specified in Requirement R9 Part 9.1 is received.

**NERC**

NORTH AMERICAN ELECTRIC  
RELIABILITY CORPORATION

# Supplemental Geomagnetic Disturbance Event Description

Project 2013-03 GMD Mitigation

June 2017

**RELIABILITY | ACCOUNTABILITY**



3353 Peachtree Road NE  
Suite 600, North Tower  
Atlanta, GA 30326  
404-446-2560 | [www.nerc.com](http://www.nerc.com)



# Table of Contents

---

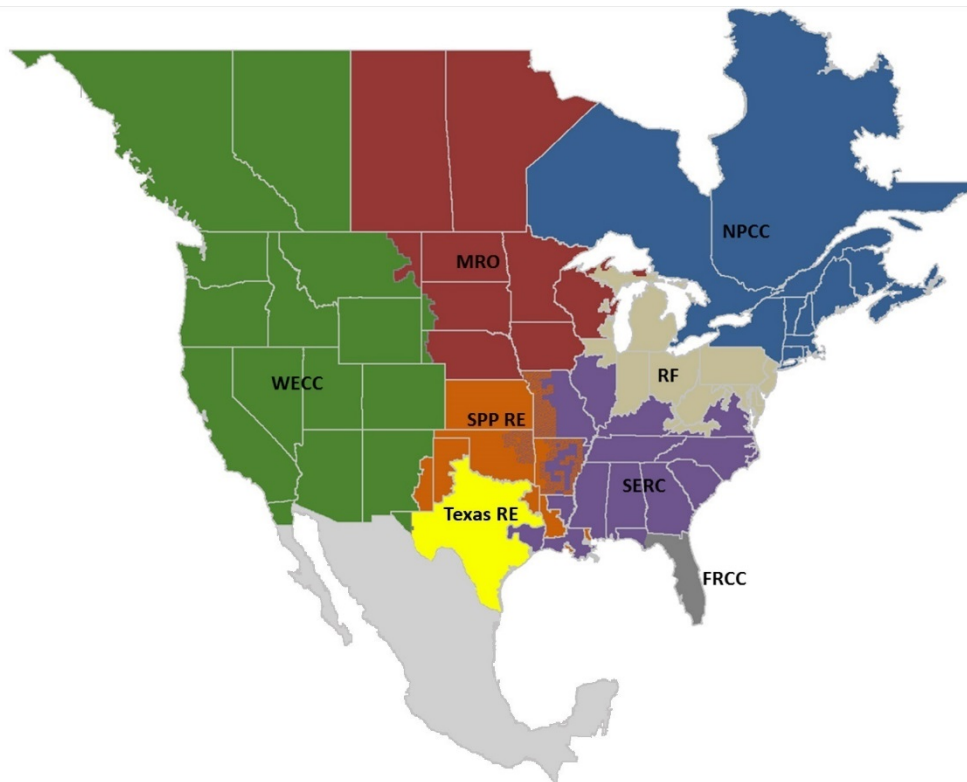
Preface.....	iii
Introduction.....	iv
Background.....	iv
General Characteristics.....	iv
Supplemental GMD Event Description.....	1
Supplemental GMD Event Geoelectric Field Amplitude.....	1
Supplemental Geomagnetic Field Waveform.....	1
Appendix I – Technical Considerations.....	3
Statistical Considerations.....	3
Extreme Value Analysis.....	4
Spatial Considerations.....	7
Local Enhancement Waveform.....	13
Transformer Thermal Assessment.....	15
Appendix II – Scaling the Supplemental GMD Event.....	16
Scaling the Geomagnetic Field.....	16
Scaling the Geoelectric Field.....	18
References.....	22

## Preface

---

The North American Electric Reliability Corporation (NERC) is a not-for-profit international regulatory authority whose mission is to assure the reliability and security of the bulk power system (BPS) in North America. NERC develops and enforces Reliability Standards; annually assesses seasonal and long-term reliability; monitors the BPS through system awareness; and educates, trains, and certifies industry personnel. NERC's area of responsibility spans the continental United States, Canada, and the northern portion of Baja California, Mexico. NERC is the Electric Reliability Organization (ERO) for North America, subject to oversight by the Federal Energy Regulatory Commission (FERC) and governmental authorities in Canada. NERC's jurisdiction includes users, owners, and operators of the BPS, which serves more than 334 million people.

The North American BPS is divided into eight Regional Entity (RE) boundaries as shown in the map and corresponding table below.



*The North American BPS is divided into eight RE boundaries. The highlighted areas denote overlap as some load-serving entities participate in one Region while associated transmission owners/operators participate in another.*

<b>FRCC</b>	Florida Reliability Coordinating Council
<b>MRO</b>	Midwest Reliability Organization
<b>NPCC</b>	Northeast Power Coordinating Council
<b>RF</b>	ReliabilityFirst
<b>SERC</b>	SERC Reliability Corporation
<b>SPP RE</b>	Southwest Power Pool Regional Entity
<b>Texas RE</b>	Texas Reliability Entity
<b>WECC</b>	Western Electricity Coordinating Council

# Introduction

---

## Background

Proposed TPL-007-2 includes requirements for entities to perform two types of GMD Vulnerability Assessments to evaluate the potential impacts of GMD events on the Bulk Electric System (BES):

- The benchmark GMD Vulnerability Assessment is based on the benchmark GMD event associated with TPL-007-1 which was approved by the Federal Energy Regulatory Commission (FERC) in Order No. 830 in September 2016. The benchmark GMD event is derived from spatially-averaged geoelectric field values to address potential wide-area effects that could be caused by a severe 1-in-100 year GMD event.<sup>1</sup>
- The supplemental GMD Vulnerability Assessment, based on the supplemental GMD event described in this white paper, is used by entities to evaluate localized enhancements of geomagnetic field during a severe GMD event that "could potentially affect the reliable operation of the Bulk-Power System".<sup>2</sup> Localized enhancements of geomagnetic field can result in geoelectric field values above the spatially-averaged benchmark in a local area.

The purpose of the supplemental geomagnetic disturbance (GMD) event description is to provide a defined event for assessing system performance for a GMD event which includes a local enhancement of the geomagnetic field. In addition to varying with time, geomagnetic fields can be spatially non-uniform with higher and lower strengths across a region. This spatial non-uniformity has been observed in a number of GMD events, so localized enhancement of field strength above the average value is considered. The supplemental GMD event defines the geomagnetic and geoelectric field values used to compute geomagnetically-induced current (GIC) flows for a supplemental GMD Vulnerability Assessment.

## General Characteristics

The supplemental GMD event described herein takes into consideration observed characteristics of a local geomagnetic field enhancement, recognizing that the science and understanding of these events is evolving. Based on observations and initial assessments, the characteristics of local enhancements include:

- Geographic area – The extent of local enhancements is on the order of 100km in North-South (latitude) direction but longer in East-West (longitude) direction. Further description of the geographic area is provided later in the white paper.
- Amplitude – The amplitude of the resulting geoelectric field is significantly higher than the geoelectric field that is calculated in the spatially-averaged Benchmark GMD event.
- Duration – The local enhancement in the geomagnetic field occurs over a time period of 2-5 minutes.
- Geoelectric field waveform – The supplemental GMD event waveform is the benchmark GMD event waveform with the addition of a local enhancement. The added local enhancement has amplitude and duration characteristics described above. The geoelectric field waveform has a strong influence on the hot spot heating of transformer windings and structural parts since thermal time constants of the transformer and time to peak of storm maxima are both on the order of minutes. The frequency content of the rate of change of the magnetic field (dB/dt) is a function of the waveform, which in turn has a direct effect on the geoelectric field since the earth response to dB/dt is frequency-dependent. As with the benchmark GMD event, the supplemental GMD event waveform is based on magnetic field data recorded by the Natural Resources Canada (NRCan) Ottawa (OTT) geomagnetic observatory during the March 13-

---

<sup>1</sup> See *Benchmark Geomagnetic Disturbance Event Description* white paper, May 12, 2016. Filed by NERC in RM 15-11 on June 28, 2016.

<sup>2</sup> See Order No. 830 P. 47. On September 22, 2016, FERC directed NERC to develop modifications to the benchmark GMD event, included in TPL-007-1, such that assessments would not be based solely on spatially averaged data.

14 1989 event. This GMD event data was selected because analysis of recorded events indicates that the OTT observatory data for this period provides conservative results when performing thermal assessments of power transformers.<sup>3</sup>

---

<sup>3</sup> See *Benchmark Geomagnetic Disturbance Event Description* white paper, page 5 and Appendix I.

## Supplemental GMD Event Description

Severe geomagnetic disturbance events are high-impact, low-frequency (HILF) events [1]; thus, GMD events used in system planning should consider the probability that the event will occur, as well as the impact or consequences of such an event. The supplemental GMD event is composed of the following elements: 1) a reference peak geoelectric field amplitude (V/km) derived from statistical analysis of historical magnetometer data; 2) scaling factors to account for local geomagnetic latitude; 3) scaling factors to account for local earth conductivity; and 4) a reference geomagnetic field time series or waveform to facilitate time-domain analysis of GMD impact on equipment.

### Supplemental GMD Event Geoelectric Field Amplitude

The supplemental GMD event field amplitude was determined through statistical analysis using the plane wave method [2]-[9] of geomagnetic field measurements from geomagnetic observatories in northern Europe [10] and the reference (Quebec) earth model shown in **Table 1** [11], supplemented by data from Greenland, Denmark and Alaska. For details of the statistical considerations, see Appendix I. The Quebec earth model is generally resistive and the geological structure is relatively well understood.

Thickness (km)	Resistivity ( $\Omega\text{-m}$ )
15	20,000
10	200
125	1,000
200	100
$\infty$	3

The statistical analysis (see Appendix I) resulted in conservative peak geoelectric field amplitude of approximately 12 V/km. For steady-state GIC and load flow analysis, the direction of the geoelectric field is assumed to be variable meaning that it can be in any direction (Eastward, Northward, or a vectorial combination thereof).

The regional geoelectric field peak amplitude,  $E_{\text{peak}}$ , to be used in calculating GIC in the GIC system model can be obtained from the reference value of 12 V/km using the following relationship

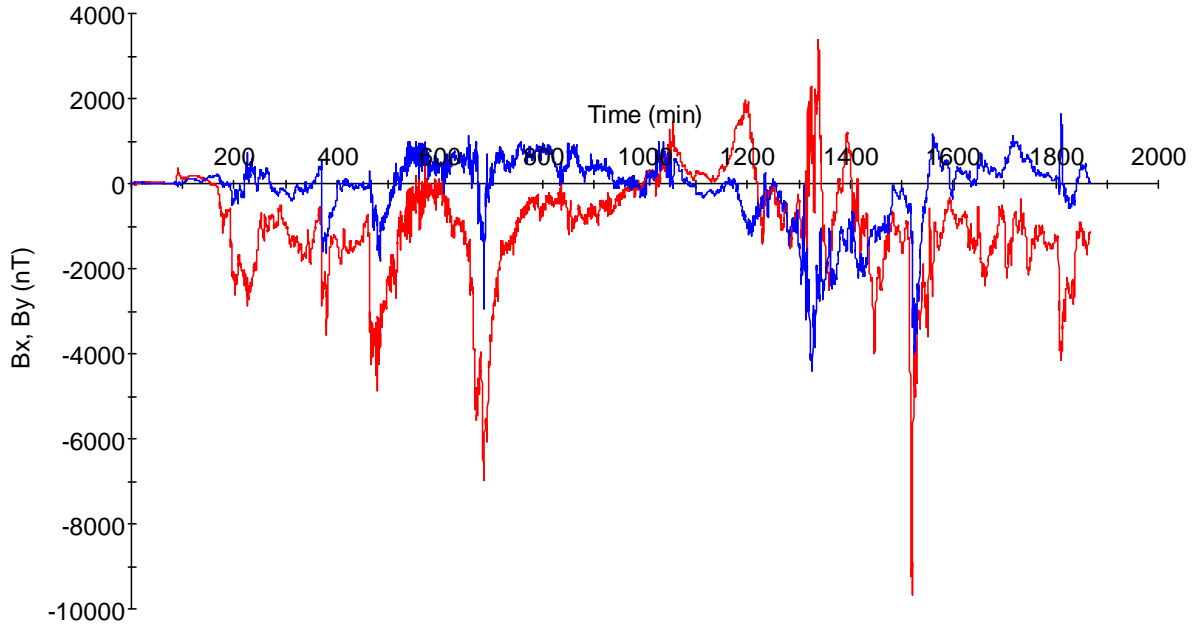
$$E_{\text{peak}} = 12 \times \alpha \times \beta_s \text{ (V/km)} \quad (1)$$

where  $\alpha$  is the scaling factor to account for local geomagnetic latitude, and  $\beta_s$  is a scaling factor for the supplemental GMD event to account for the local earth conductivity structure (see Appendix II).

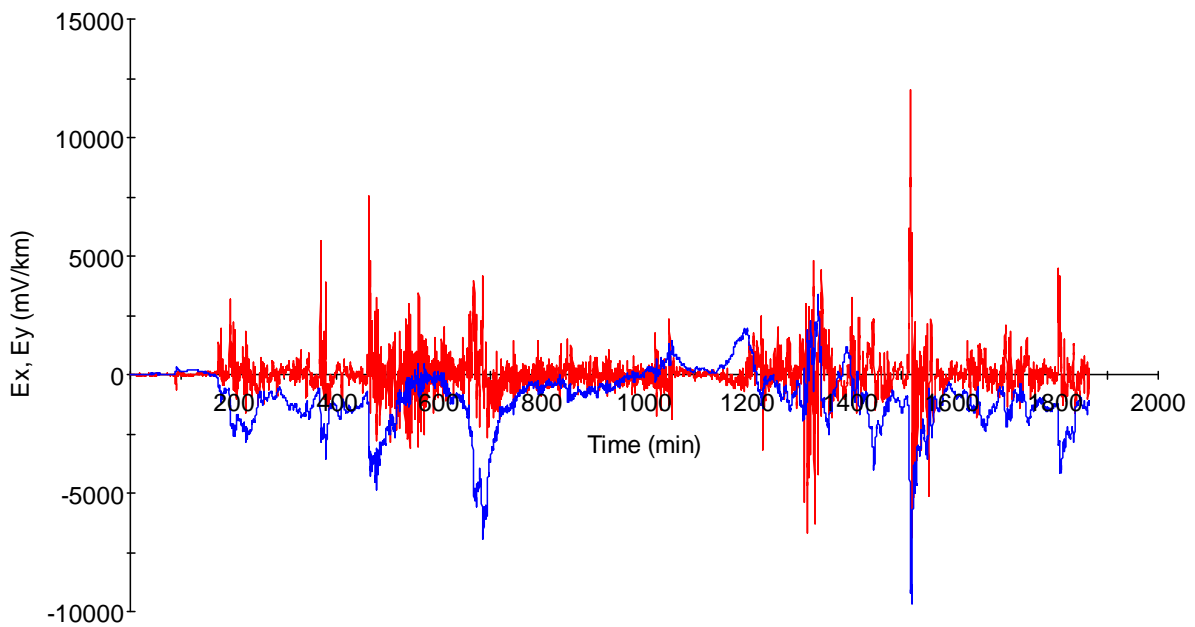
### Supplemental Geomagnetic Field Waveform

The supplemental geomagnetic field waveform is the benchmark geomagnetic field waveform with the addition of a local enhancement. Both the benchmark and supplemental geomagnetic field waveforms are used to calculate the GIC time series,  $\text{GIC}(t)$ , required for transformer thermal impact assessments. The supplemental waveform includes a local enhancement, inserted at UT 1:18 March 14 in **Figure 1** below. This time corresponds to the largest calculated geoelectric fields during the benchmark GMD event. The amplitude of the local enhancement is based on a statistical analysis of a number of GMD events, discussed in Appendix I. The duration of the enhancement is based on the characteristics of observed localized enhancements as discussed in Appendix I.

The geomagnetic latitude of the Ottawa geomagnetic observatory is 55°; therefore, the amplitude of the geomagnetic field measurement data with a local enhancement was scaled up to the 60° reference geomagnetic latitude (see **Figure 1**) such that the resulting peak geoelectric field amplitude computed using the reference earth model was 12 V/km (see **Figure 2**). Sampling rate for the geomagnetic field waveform is 10 seconds.



**Figure 1: Supplemental Geomagnetic Field Waveform**  
 Red  $B_x$  (Northward), Blue  $B_y$  (Eastward),  
 Referenced to pre-event quiet conditions



**Figure 2: Supplemental Geoelectric Field Waveform**  
 Red  $E_y$  (Eastward), Blue  $E_x$  (Northward)

## Appendix I – Technical Considerations

---

The following sections describe the technical justification of the assumptions that were made in the development of the supplemental GMD event.

### Statistical Considerations

The peak geoelectric field amplitude of the supplemental GMD event was determined through statistical analysis of modern 10-second geomagnetic field data and corresponding calculated geoelectric field amplitudes. The objective of the analysis was to estimate the geoelectric field amplitude that is associated with a 1 in 100 year frequency of occurrence. The same data set and similar statistical techniques were used in determining the peak geoelectric field amplitude of the benchmark GMD event, including extreme value analysis discussed in the following section.<sup>4</sup> The fundamental difference in the supplemental GMD event amplitude is that it is based on observations taken at each individual station (i.e., localized measurements), in contrast with the spatially averaged geoelectric fields used in the *Benchmark Geomagnetic Disturbance Event Description* white paper.<sup>5</sup>

---

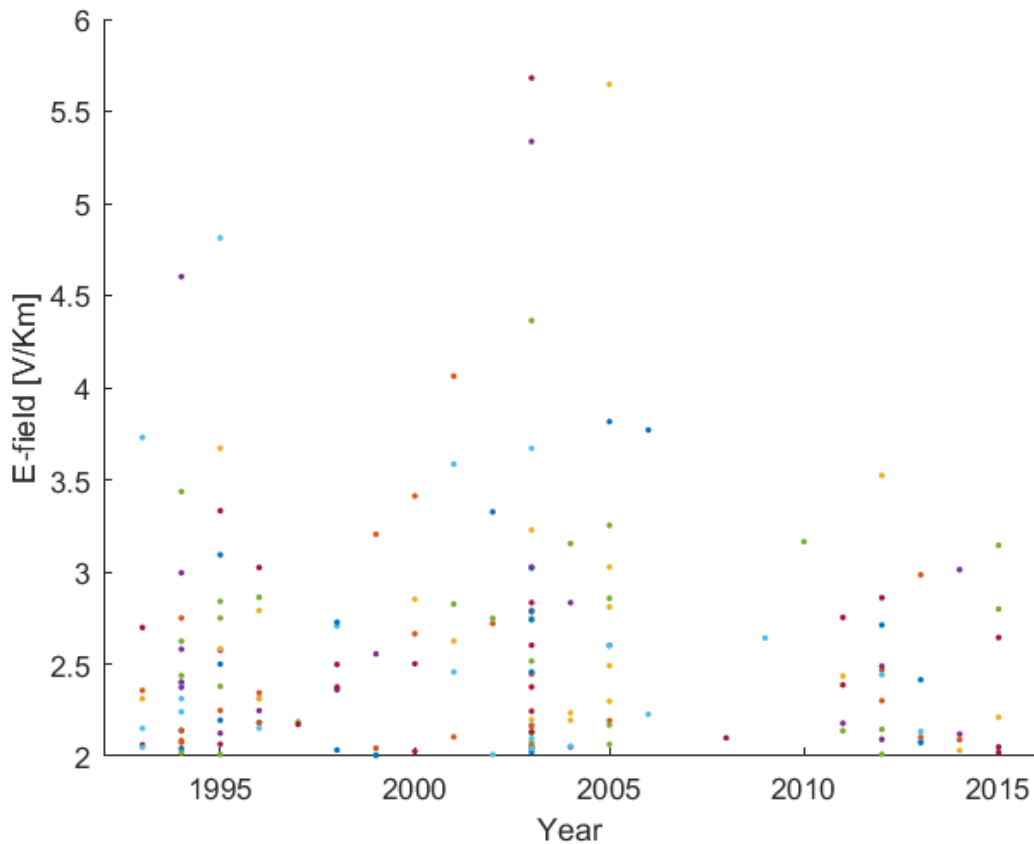
<sup>4</sup> See *Benchmark Geomagnetic Disturbance Event Description* white paper, Appendix I, pages 8-13.

<sup>5</sup> Averaging the geoelectric field values of stations in geographic groups is referred to as spatial averaging in the *Benchmark Geomagnetic Disturbance Event Description*. Spatial averaging was used to characterize GMD events over a geographic area relevant to the interconnected transmission system for purposes of assessing area effects such as voltage collapse and widespread equipment risk. See *Benchmark Geomagnetic Disturbance Event Description* white paper, Appendix I, pages 9-10.

### Extreme Value Analysis

The objective of extreme value analysis is to describe the behavior of a stochastic process at extreme deviations from the median. In general, the intent is to quantify the probability of an event more extreme than any previously observed. In particular, we are concerned with estimating the 95% confidence interval of the maximum geoelectric field amplitude to be expected within a 100-year return period.<sup>6</sup>

The data set consists of 23 years of daily maximum geoelectric field amplitudes derived from individual stations in the IMAGE magnetometer chain, using the Quebec earth model as a reference. **Figure I-1** shows a scatter plot of geoelectric field amplitudes that exceed 2 V/km across the IMAGE stations. The plot indicates that there is seasonality in extreme observations associated with the 11-year solar cycle.



**Figure I-1: Scatter Plot of Geoelectric Fields that Exceed a 2 V/km Threshold**

Data source: IMAGE magnetometer chain from 1993-2015.

<sup>6</sup> A 95 percent confidence interval means that, if repeated samples were obtained, the return level would lie within the confidence interval for 95 percent of the samples.



Several statistical methods can be used to conduct extreme value analysis. The most commonly applied include: Generalized Extreme Value (GEV), Point Over Threshold (POT), R-Largest, and Point Process (PP). In general, all methods assume independent and identically distributed (iid) data [12].

**Table I-1** shows a summary of the estimated parameters and return levels obtained from different statistical methods. The parameters were estimated using the Maximum Likelihood Estimator (MLE). Since the distribution parameters do not have an intuitive interpretation, the expected geoelectric field amplitude for a 100-year return period is also included in **Table I-1**. The 95% confidence interval of the 100-year return level was calculated using the delta method and the profile likelihood. The delta method relies on the Gaussian approximation to the distribution of the MLE; this approximation can be poor for long return periods. In general, the profile likelihood provides a better description of the return level.

Table I-1: Extreme Value Analysis					
Statistical Model	Estimated Parameters	Hypothesis Testing	100 Year Return Level		
			Mean [V/km]	95% CI Delta [V/km]	95% CI P-Likelihood [V/km]
(1) GEV	$\mu=2.976$ (0.193) $\sigma=0.829$ (0.1357) $\xi=-0.0655$ (0.1446)	H0: $\xi=0$ $p = 0.66$	6.9	[4.3, 8.2]	[5.2, 11.4]
(2) GEV, reparametrization $\mu = \beta_0 + \beta_1 \cdot \sin\left(\frac{t}{T} + \phi\right)$	$\beta_0= 2.964$ (0.151) $\beta_1=0.582$ (0.155) $\sigma=0.627$ (0.114) $\xi=0.09$ (0.183)	H0: $\beta_1=0$ $p = 0.00$  H0: $\xi=0$ $p = 0.6$	7.1	[4, 10.2]	[5.5, 18]
(3) POT, threshold=2 V/km 3 day decluster. 143 observations > 2V/km.	$\sigma=0.592$ (0.074) $\xi=0.077$ (0.093)		6.9	[4.5, 9.4]	[5.4, 11.9]
(4) POT, threshold=2V/km reparametrization, $\sigma = \beta_0 + \beta_1 \cdot \sin\left(\frac{t}{T} + \phi\right)$	$\beta_0=0.58$ (0.073) $\beta_1=0.107$ (0.082) $\xi=0.037$ (0.097)	H0: $B1=0$ $p = 0.2$	7	[4.6, 9.3]	[5.5, 11.7]

Statistical model (1) in **Table I-1** is the traditional GEV estimation using blocks of 1 year maxima; i.e., only 23 data points are used in the estimation. The mean expected amplitude of the geoelectric field for a 100-year return level is approximately 7 V/km. Since GEV works with blocks of maxima, it is typically regarded as a wasteful approach.

As discussed previously, GEV assumes that the data is iid. Based on the scatter plot shown in **Figure I-1**, the iid statistical assumption is not warranted by the data. Statistical model (2) in **Table I-1** is a reparametrization of the GEV distribution contemplating the 11-year seasonality in the mean,

$$\mu = \beta_0 + \beta_1 \cdot \sin\left(\frac{t}{T} + \phi\right)$$

where  $\beta_0$  represents the offset in the mean,  $\beta_1$  describes the 11-year seasonality,  $T$  is the period (11 years), and  $\phi$  is a constant phase shift.

A likelihood ratio test is used to test the hypothesis that  $\beta_1$  is zero. The null hypothesis,  $H_0: \beta_1=0$ , is rejected with a p-value of 0.0032; as expected, the 11-year seasonality has explanatory power. The blocks of maxima during the solar minimum are better represented in the reparametrized GEV. The mean return level is still 7 V/km, but the confidence interval is wider, [5.5, 18] V/km for the profile likelihood (calculated at solar maximum).

Statistical model (3) in **Table I-1** is the traditional POT estimation using a threshold  $u$  of 2 V/km; the data was declustered using a 1-day run. The data set consists of normalized excesses over a threshold, and therefore, the sample size for POT is increased if more than one extreme observation per year is available (in the GEV approach, only the maximum observation over the year was taken; in the POT method, a single year can have multiple observations over the threshold). The selection of the threshold  $u$  is a compromise between bias and variance. The asymptotic basis of the model relies on a high threshold; too low a threshold will likely lead to bias. On the other hand, too high a threshold will reduce the sample size and result in high variance. A threshold of 2V/km was determined to be a good choice, giving rise to 143 observations above the threshold.

The mean return level for statistical model (3),  $\sim 7$  V/km, is consistent with the GEV estimates. However, due to the larger sample size the POT method is more efficient rendering a confidence interval of [5.4, 11.9] V/km for the profile likelihood method.

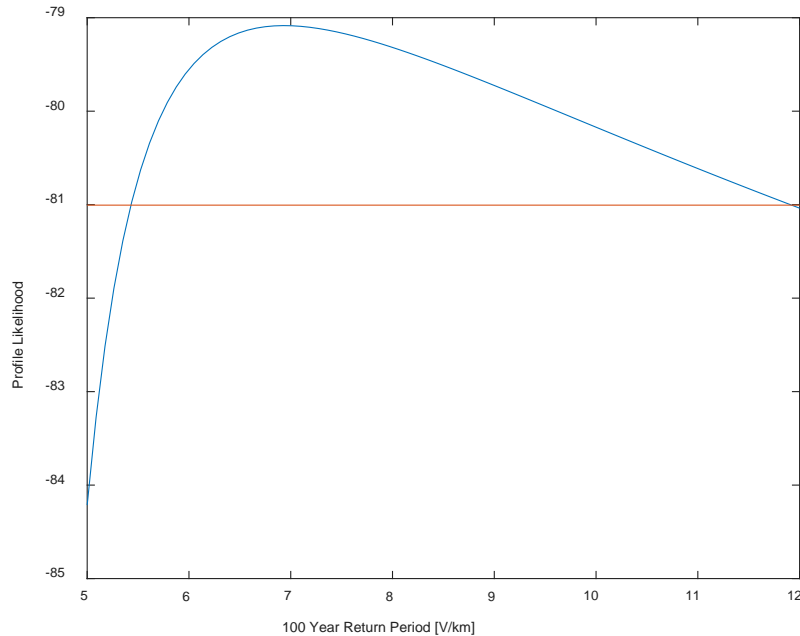
In an attempt to cope with potential heteroskedasticity in the data, a reparametrization of POT is proposed in statistical model (4) in **Table I-1**,

$$\sigma = \alpha_0 + \alpha_1 \cdot \sin\left(\frac{t}{T} + \phi\right)$$

where  $\alpha_0$  represents the offset in the standard deviation,  $\alpha_1$  describes the 11-year seasonality,  $T$  is the period ( $365.25 \cdot 11$ ), and  $\phi$  is a constant phase shift.

The parameter  $\alpha_1$  is not statistically significant; the null hypothesis,  $H_0: \alpha_1=0$ , is not rejected with a p-value of 0.2. The proposed reparametrization does not have explanatory power, and consequently, the mean return level 7 V/km and confidence intervals remain virtually unchanged [5.5, 11.7]. As a final remark, it is emphasized that the confidence interval obtained using the profile likelihood is preferred over the delta method.

**Figure I-2** shows the profile likelihood of the 100-year return level of statistical model (3). Note that the profile likelihood is highly asymmetric with a positive skew, rendering a larger upper limit for the confidence interval. Recall that the delta method assumes a normal distribution for the MLEs, and therefore, the confidence interval is symmetric around the mean.



**Figure I-2: Profile Likelihood for 100-year Return Level for Statistical Model (3)**

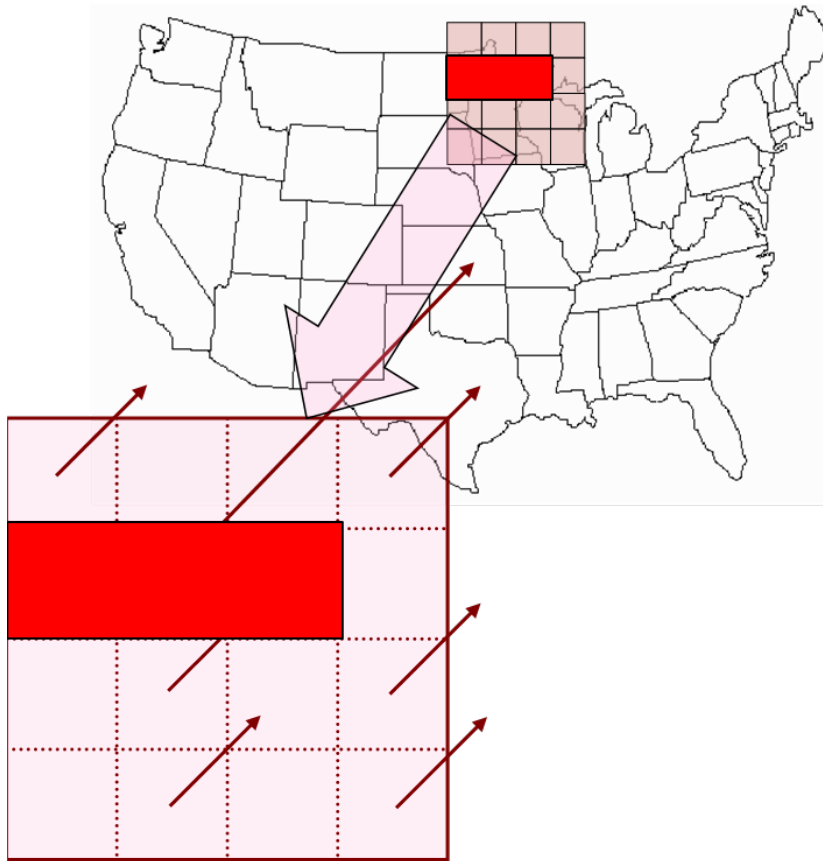
To conclude, the traditional GEV (1) is misspecified; the statistical assumptions (iid) are not warranted by the data. The model was reparametrized to cope with seasonality in the data. Statistical models (3) and (4) better utilize the available extreme measurements and they are therefore preferred over statistical model (2). A geoelectric field amplitude of 12 V/km is selected for the supplemental GMD event to represent the upper limit of the 95 percent confidence interval for a 100-year return interval.

## Spatial Considerations

The spatial structure of high-latitude geomagnetic fields can be very complex during strong geomagnetic storm events [13]-[14]. One reflection of this spatial complexity is localized geomagnetic field enhancements (local enhancements) that result in high amplitude geoelectric fields in regions of a few hundred kilometers. **Figure I-3** illustrates this spatial complexity of the storm-time geoelectric fields.<sup>7</sup> In areas indicated by the bright red location, the geoelectric field can be substantially larger than at neighboring locations. These enhancements are primarily the result of external (geomagnetic field) conditions, and not local geological factors such as coastal effects.<sup>8</sup>

<sup>7</sup> **Figure I-3** is for illustration purposes only, and is not meant to suggest that a particular area is more likely to experience a localized enhanced geoelectric field. The depiction is not to scale.

<sup>8</sup> Localized externally-driven geomagnetic phenomena should not be confused with localized geoelectric field enhancements due to complex electromagnetic response of the ground to external excitation. Complex 3D geological conditions such as those at coastal regions can lead to localized geoelectric field enhancements but those are not considered here.



**Figure I-3: Illustration of the Spatial Scale between Localized Enhancements and Larger Spatial Scale Amplitudes of Geoelectric Field during a Strong Geomagnetic Storm.**

In this figure, the red rectangle illustrates a spatially localized field enhancement.

The supplemental GMD event is designed to address local effects caused by a severe GMD event, such as increased var absorption and voltage depressions.

A number of GMD events were analyzed to identify the basic characteristics of local enhancements. Three (3) solar storms studied and described below are:

- March 13, 1989
- October 29-30, 2003
- March 17, 2015

Four localized events within those storms were identified and analyzed. Geomagnetic field recordings were collected for these storms and the geoelectric field was computed using the 1D plane wave method and the reference Quebec ground model. In each case, a local enhancement was correlated, generally oriented parallel to the westward ionospheric electrojet associated with ongoing larger scale geomagnetic activity. (See **Figures I-4 – I-7** below)

Goelectric field distribution 0089-03-13T21:44:00 UT. Max. IEI: 5.90 V/km.

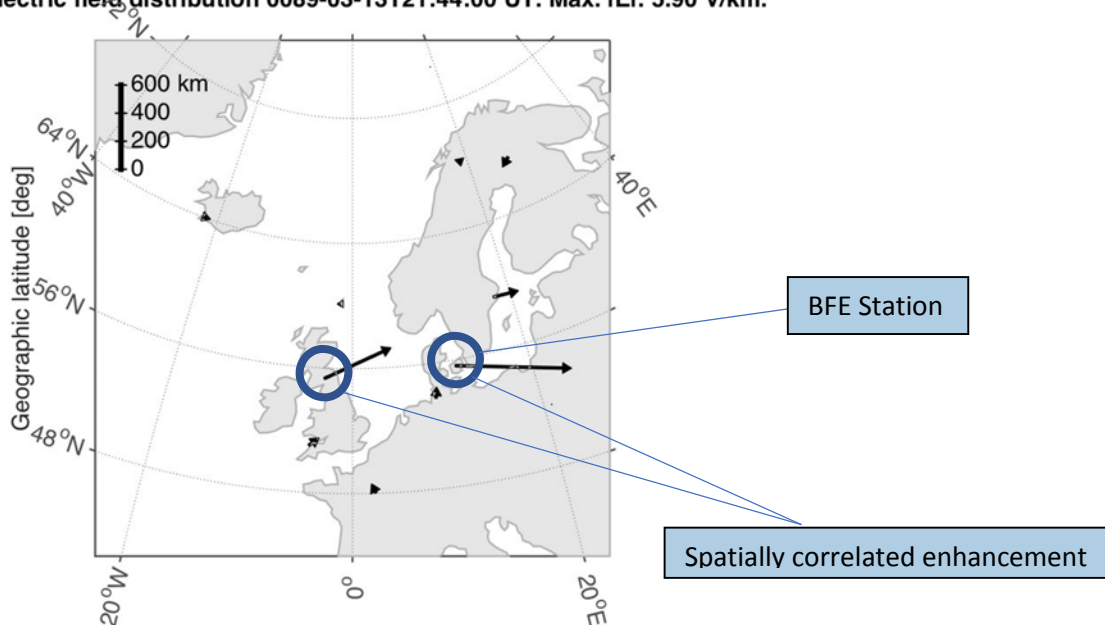


Figure I-4: March 13, 1989, at 21:44 UT, Brorfelde (BFE), Denmark

Goelectric field distribution 2003-10-29T06:47:20 UT. Max. IEI: 9.31 V/km.

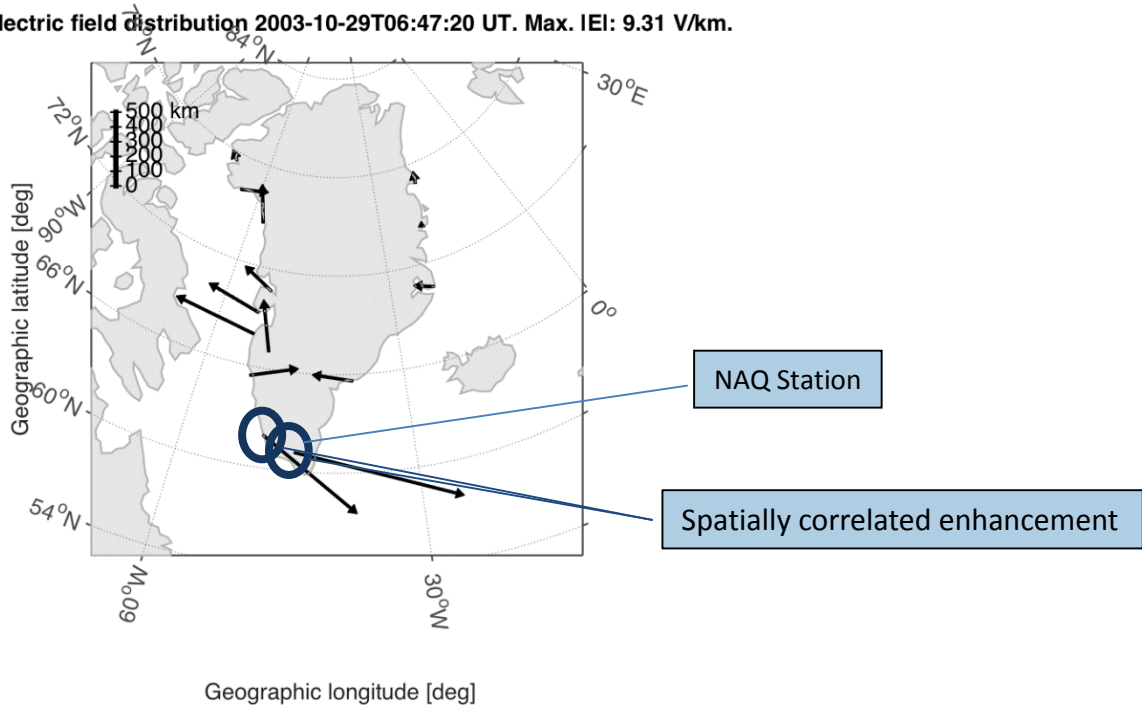


Figure I-5: October 29, 2003, at 06:47 UT, Narsarsuaq (NAQ), Greenland

Goelectric field distribution 2003-10-30T16:49:30 UT. Max. IEI: 5.68 V/km.

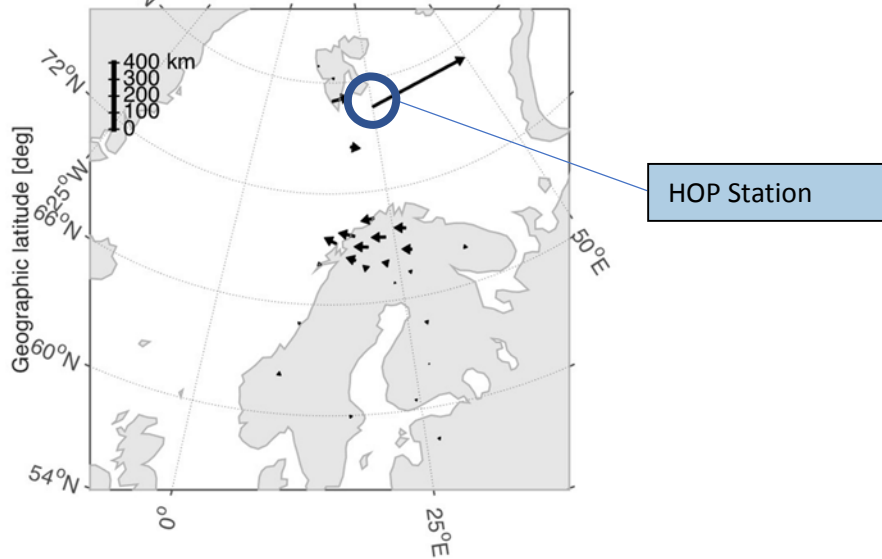


Figure I-6: October 30, 2003, at 16:49UT, Hopen Island (HOP), Svalbard, Norway

Goelectric field distribution 2015-03-17T13:33:00 UT. Max. IEI: 3.46 V/km.

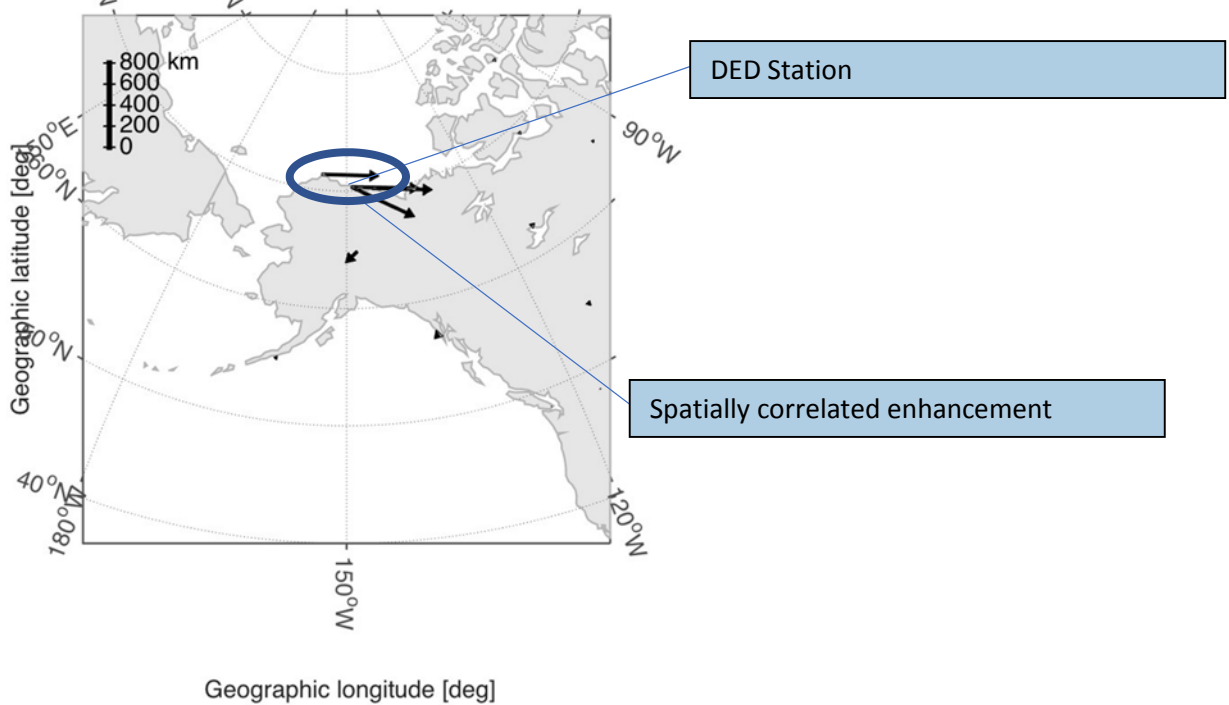
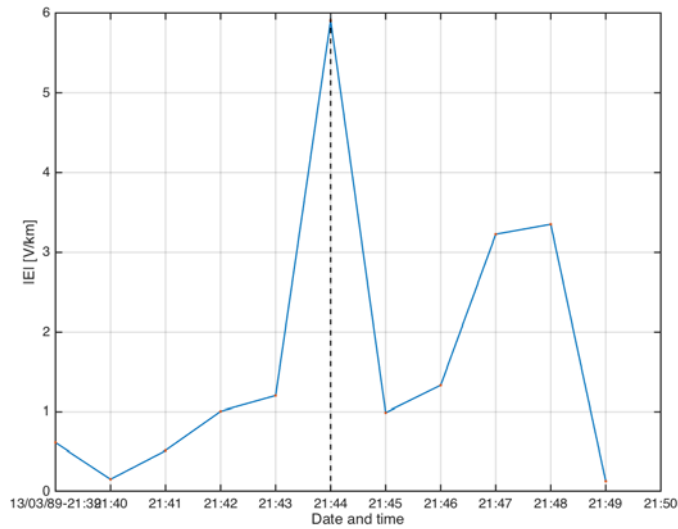


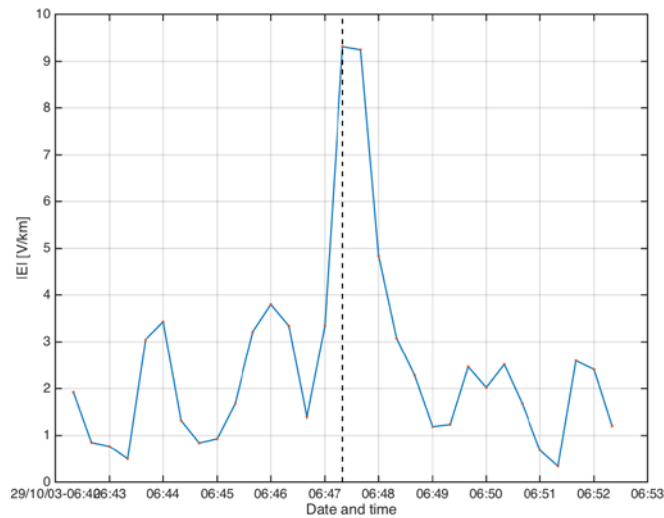
Figure I-7: March 17, 2015, at 13:33 UT, Deadhorse, Alaska

All of the above events were analyzed by reviewing the time series magnetic field data and transforming it to an electric field and focusing on the time period of the spatially correlated local enhancement. There were apparent similarities in the character of the local enhancements. The local enhancements occurred during peak periods of

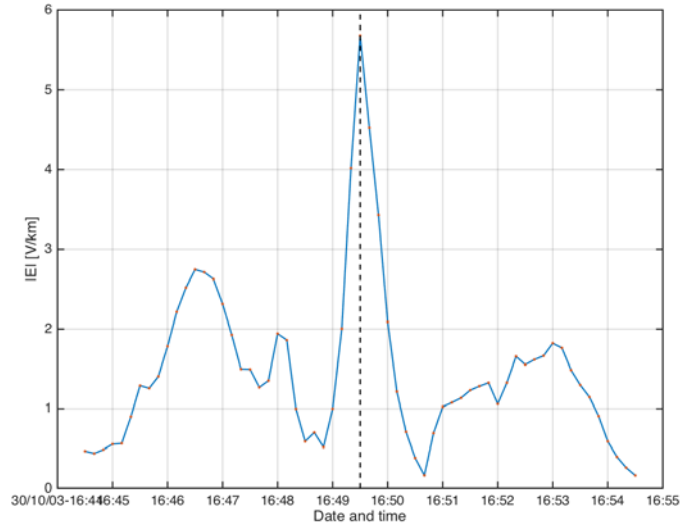
geomagnetic activity and were distinguished by relatively brief excursions of rapid magnetic field variation. With respect to time duration, the local enhancements generally occurred over a period of 2-5 minutes. (See **Figures I-8 – I-11**)



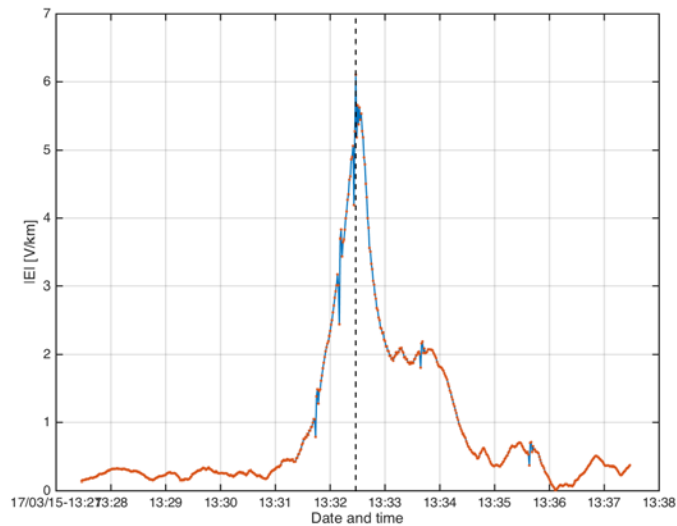
**Figure I-8: Geoelectric field March 13, 1989, at 21:44 UT, Brorfelde (BFE), Denmark.**



**Figure I-9: Geoelectric field October 29, 2003, at 06:47 UT, Narsarsuaq (NAQ), Greenland**



**Figure I-10: Geoelectric field October 30, 2003, at 16:49UT, Hopen Island (HOP), Norway**



**Figure I-11 – Geoelectric field March 17, 2015, at 13:33 UT, Deadhorse, Alaska**

Based on the above analysis and the previous work associated with the benchmark GMD event, it is reasonable to incorporate a second (or supplemental) assessment into TPL-007 to account for the potential impact of a local enhancement in both the network analysis and the transformer thermal assessment(s).

With respect to geographic area of the localized enhancement, the historical geomagnetic field data analyzed so far provides some insight. Analysis suggests that the enhancements will occur in a relatively narrow band of geomagnetic latitude (on the order of 100 km) and wider longitudinal width (on the order of 500 km) as a consequence of the westward-oriented structure of the source in the ionosphere.

Proposed TPL-007-2 provides flexibility for planners to determine how to apply the supplemental GMD event to the planning area. Acceptable approaches include but are not limited to:

- Apply the peak geoelectric field for the supplemental GMD event (12 V/km scaled to the planning area) over the entire planning area;

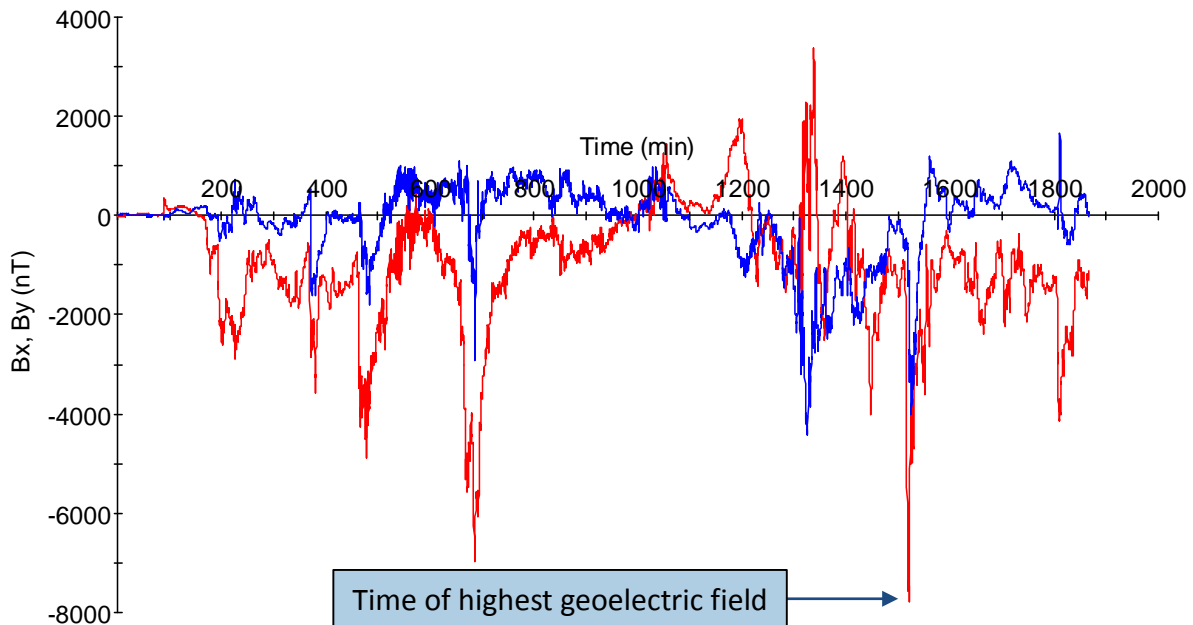


- Apply a spatially limited (e.g., 100 km in North-South direction and 500 km in East-West direction) geoelectric field enhancement (12 V/km scaled to the planning area) over a portion(s) of the system, and apply the benchmark GMD event over the rest of the system.
- Other methods to adjust the benchmark GMD event analysis for localized geoelectric field enhancement.

Given the current state of knowledge regarding the spatial extent of a local geomagnetic field enhancements, upper geographic boundaries, such as the values used in the approaches above, are reasonable but are not definitive.

## Local Enhancement Waveform

The supplemental geomagnetic field waveform was derived by modifying the benchmark GMD event waveform to emulate the observed events described above. The temporal location of the enhancement corresponds to the time of the benchmark event with the highest geoelectric field. The local enhancement was constructed by scaling linearly a 5-minute portion of the benchmark geomagnetic field so that the peak geoelectric field is 12 V/km at a geomagnetic latitude of 60° and reference earth model. **Figure I-12** shows the benchmark geomagnetic field and **Figure I-13** shows the supplemental event geomagnetic field. **Figure I-14** expands the view into  $B_x$ , with and without the local enhancement. **Figure I-15** is the corresponding expanded view of the geoelectric field magnitude with and without the local enhancement.



**Figure I-12: Benchmark Geomagnetic Field. Red  $B_x$  (Northward), Blue  $B_y$  (Eastward)**

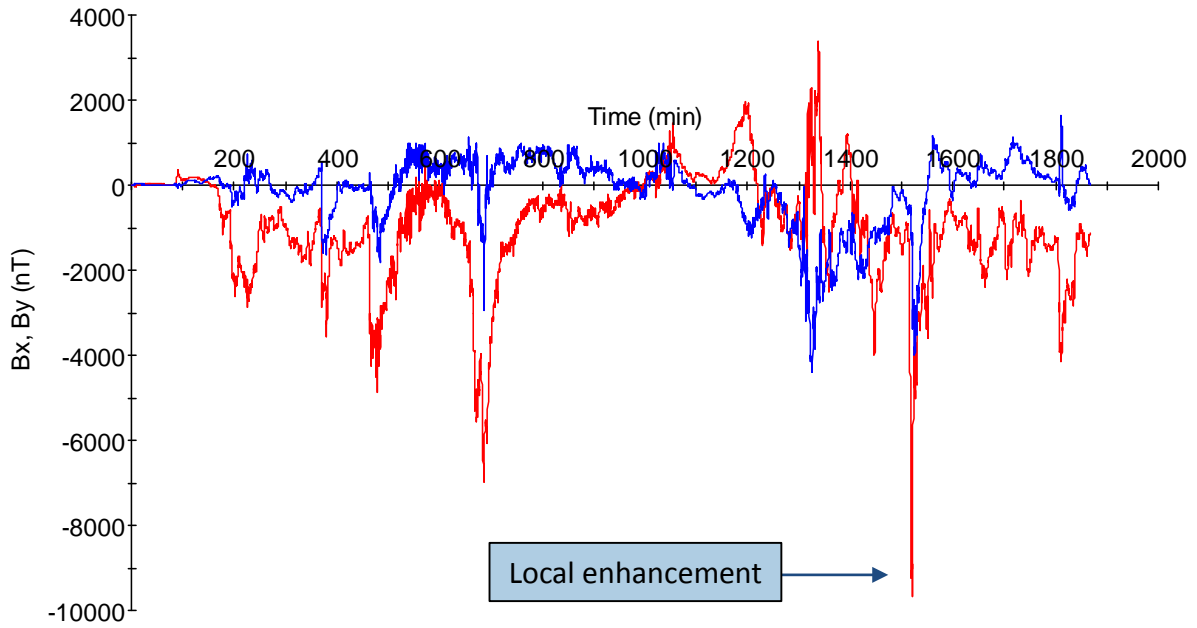


Figure I-13: Supplemental Geomagnetic Field Waveform. Red B<sub>x</sub> (Northward), Blue B<sub>y</sub> (Eastward)

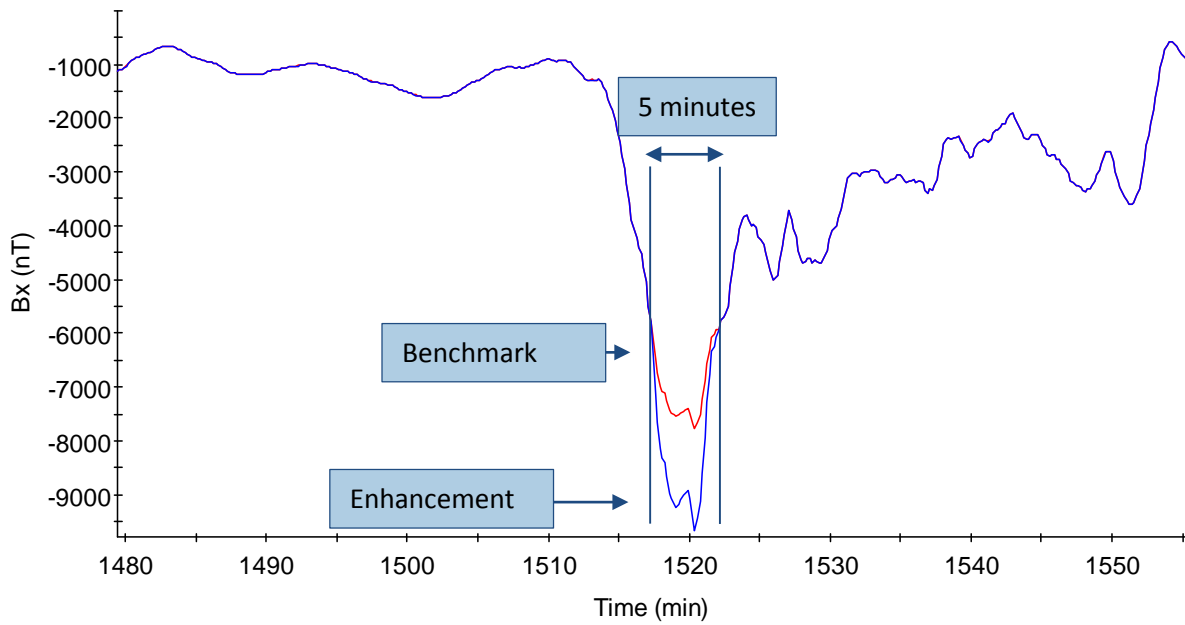
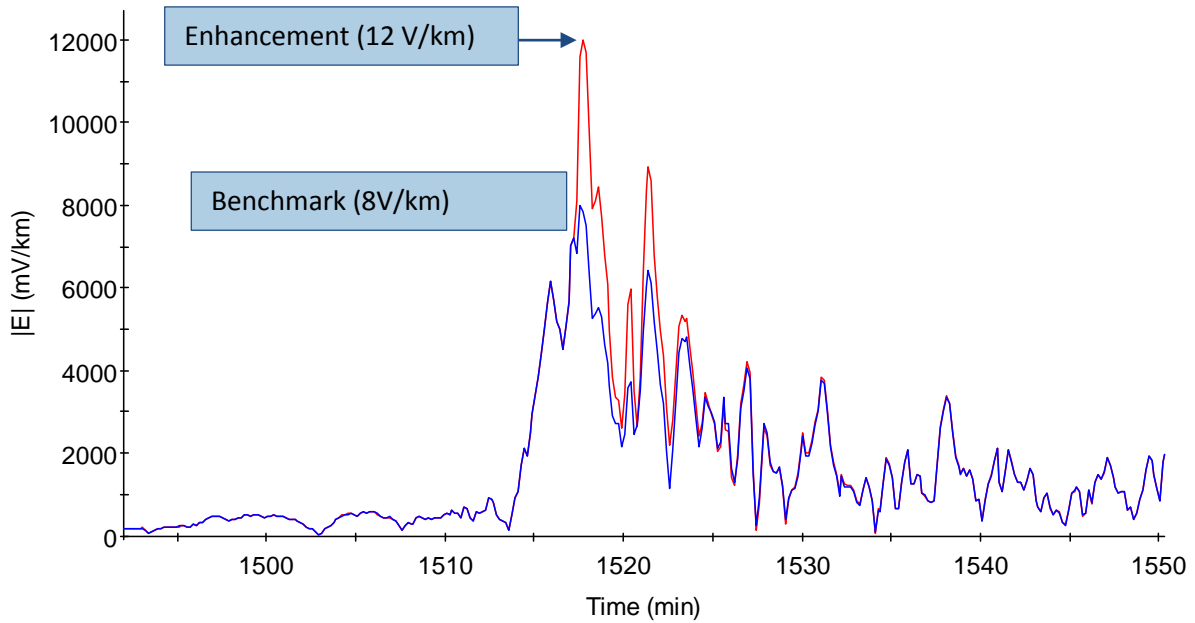


Figure I-14: Red Benchmark B<sub>x</sub> and Blue Supplemental B<sub>x</sub> (Northward) – Expanded View



**Figure I-15: Magnitude of the Geoelectric Field. Benchmark Blue and Supplemental Red – Expanded View**

## Transformer Thermal Assessment

The local enhancement of the supplemental GMD event waveform can have a material impact on the temperature rise (hot-spot heating or metallic parts) even though the duration of the local enhancement is approximately 5 minutes. Thermal assessments based on the supplemental GMD event can be performed using the same methods employed for benchmark thermal assessments.<sup>9</sup>

<sup>9</sup> See Transformer Thermal Impact Assessment white paper: <http://www.nerc.com/pa/Stand/Pages/Project-2013-03-Geomagnetic-Disturbance-Mitigation.aspx>

## Appendix II – Scaling the Supplemental GMD Event

---

The intensity of a GMD event depends on geographical considerations such as geomagnetic latitude and local earth conductivity [2].<sup>10</sup> Scaling factors for geomagnetic latitude take into consideration that the intensity of a GMD event varies according to latitude-based geographical location. Scaling factors for earth conductivity take into account that the induced geoelectric field depends on earth conductivity, and that different parts of the continent have different earth conductivity and deep earth structure.

Scaling the supplemental GMD event differs from the benchmark GMD event in two ways:

- $E_{\text{peak}}$  is 12 V/km instead of 8 V/km
- Beta factors for scaling the geoelectric field based on earth conductivity are different (see **Table II-2**)

More discussion, including example calculations, is contained in the Benchmark GMD Event Description white paper.

### Scaling the Geomagnetic Field

The supplemental GMD event is defined for geomagnetic latitude of 60° and it must be scaled to account for regional differences based on geomagnetic latitude. To allow usage of the supplemental geomagnetic field waveform in other locations, **Table II-1** summarizes the scaling factor  $\alpha$  correlating peak geoelectric field to geomagnetic latitude as described in **Figure II-1** [3]. This scaling factor  $\alpha$  has been obtained from a large number of global geomagnetic field observations of all major geomagnetic storms since the late 1980s [15]-[27], and can be approximated with the empirical expression in (II.1)

$$\alpha = 0.001 \cdot e^{(0.115 \cdot L)} \quad (\text{II.1})$$

where L is the geomagnetic latitude in degrees and  $0.1 \leq \alpha \leq 1.0$ .

---

<sup>10</sup> Geomagnetic latitude is analogous to geographic latitude, except that bearing is in relation to the magnetic poles, as opposed to the geographic poles. Geomagnetic phenomena are often best organized as a function of geomagnetic coordinates. Local earth conductivity refers to the electrical characteristics to depths of hundreds of km down to the earth's mantle. In general terms, lower ground conductivity results in higher geoelectric field amplitudes.

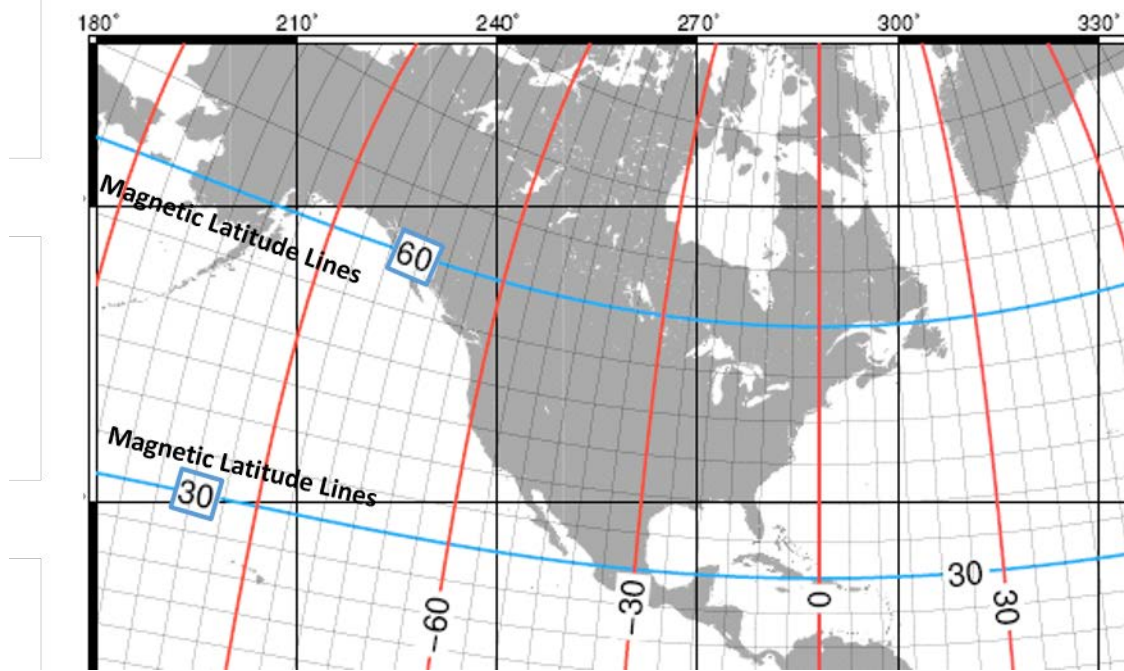


Figure II-1: Geomagnetic Latitude Lines in North America

Table II-1: Geomagnetic Field Scaling Factors	
Geomagnetic Latitude (Degrees)	Scaling Factor1 ( $\alpha$ )
$\leq 40$	0.10
45	0.2
50	0.3
54	0.5
56	0.6
57	0.7
58	0.8
59	0.9
$\geq 60$	1.0

## Scaling the Goelectric Field

The supplemental GMD event is defined for the reference Quebec earth model provided in **Table 1**. This earth model has been used in many peer-reviewed technical articles [11, 15]. The peak goelectric field depends on the geomagnetic field waveform and the local earth conductivity. Ideally, the peak goelectric field,  $E_{peak}$ , is obtained by calculating the goelectric field from the scaled geomagnetic field waveform using the plane wave method and taking the maximum value of the resulting waveforms

$$\begin{aligned} E_N &= (z(t) / \mu_o) * B_E(t) \\ E_E &= -(z(t) / \mu_o) * B_N(t) \\ E_{peak} &= \max\{|E_E(t), E_N(t)|\} \end{aligned} \tag{II.2}$$

where,

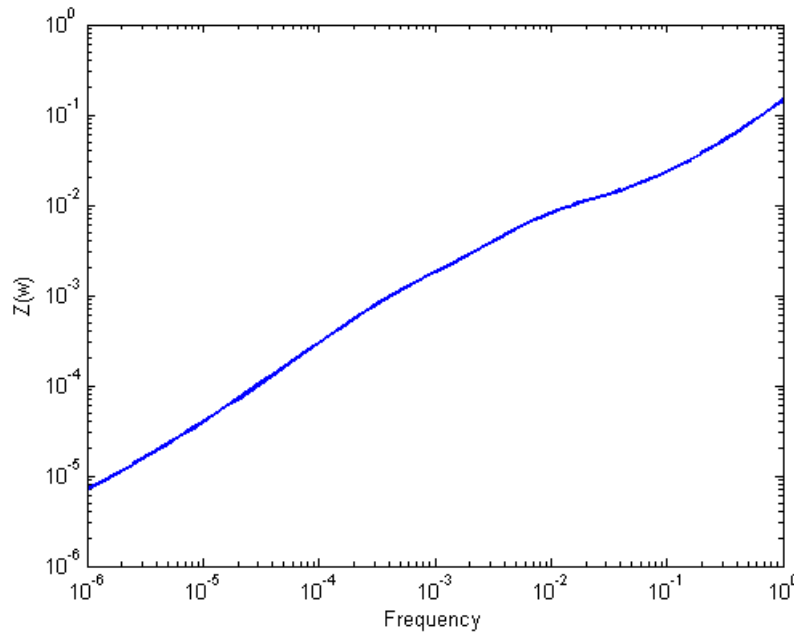
\* denotes convolution in the time domain,

$z(t)$  is the impulse response for the earth surface impedance calculated from the laterally uniform or 1D earth model,

$B_E(t)$ ,  $B_N(t)$  are the scaled Eastward and Northward geomagnetic field waveforms,

$E_E(t)$ ,  $E_N(t)$  are the magnitudes of the calculated Eastward and Northward goelectric field  $E_E(t)$  and  $E_N(t)$ .

As noted previously, the response of the earth to  $B(t)$  (and  $dB/dt$ ) is frequency dependent. **Figure II-2** shows the magnitude of  $Z(\omega)$  for the reference earth model.



**Figure II-2: Magnitude of the Earth Surface Impedance for the Reference Earth Model**

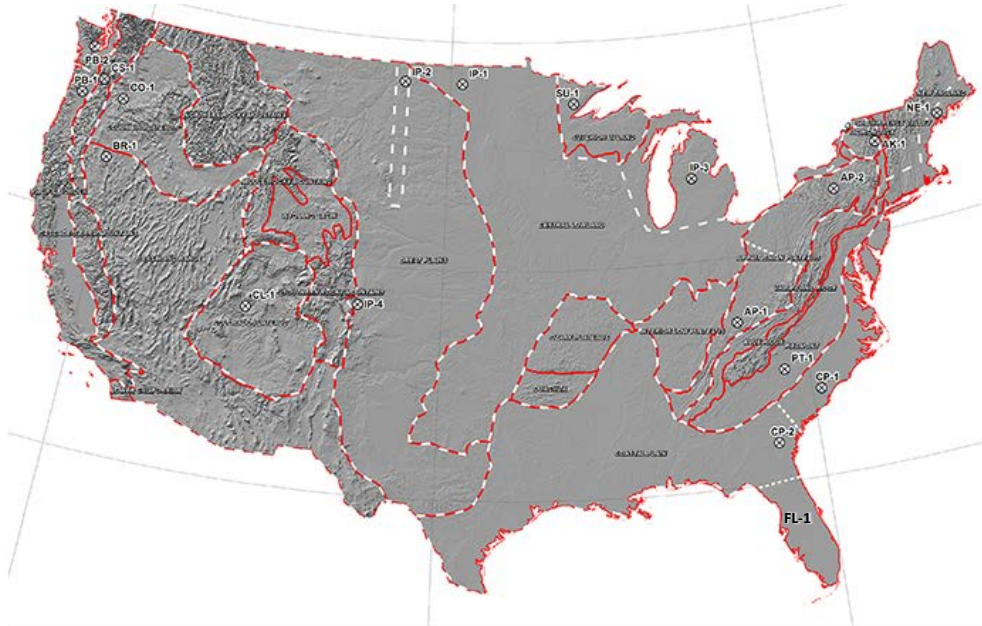
If a utility does not have the capability of calculating the waveform or time series for the goelectric field, an earth conductivity scaling factor  $\beta_s$  can be obtained from **Table II-2**. Using  $\alpha$  and  $\beta$ , the peak goelectric field  $E_{peak}$  for a specific service territory shown in **Figure II-3** can be obtained using (II.3)

$$E_{peak} = 12 \times \alpha \times \beta_s \text{ (V/km)} \tag{II.3}$$

It should be noted that (II.3) is an approximation based on the following assumptions:

- The earth models used to calculate Table II-2 for the United States are from published information available on the USGS website. These scaling factors are slightly lower than the ones in the benchmark because the supplemental benchmark waveform has a higher frequency content at the time of the local enhancement.
- The models used to calculate Table II-2 for Canada were obtained from NRCan and reflect the average structure for large regions. When models are developed for sub-regions, there will be variance (to a greater or lesser degree) from the average model. For instance, detailed models for Ontario have been developed by NRCan and consist of seven major sub-regions.
- The conductivity scaling factor  $\beta_s$  is calculated as the quotient of the local geoelectric field peak amplitude in a physiographic region with respect to the reference peak amplitude value of 12 V/km. Both geoelectric field peak amplitudes are calculated using the supplemental geomagnetic field time series. If a different geomagnetic field time series were used, the calculated scaling factors ( $\beta$ ) would be different than the values in Table II-2 because the frequency content of storm maxima is, in principle, different for every storm. If a utility has technically-sound earth models for its service territory and sub-regions thereof, then the use of such earth models is preferable to estimate  $E_{\text{peak}}$ .
- When a ground conductivity model is not available the planning entity should use the largest  $\beta_s$  factor of adjacent physiographic regions or a technically-justified value.

Physiographic Regions of the Continental United States



Physiographic Regions of Canada



Figure II-3: Physiographic Regions of North America



<b>Table II-2 Supplemental Geoelectric Field Scaling Factors</b>	
<b>Earth model</b>	<b>Scaling Factor (<math>\beta</math>)</b>
AK1A	0.51
AK1B	0.51
AP1	0.30
AP2	0.78
BR1	0.22
CL1	0.73
CO1	0.25
CP1	0.77
CP2	0.86
FL1	0.73
CS1	0.37
IP1	0.90
IP2	0.25
IP3	0.90
IP4	0.35
NE1	0.77
PB1	0.55
PB2	0.39
PT1	1.19
SL1	0.49
SU1	0.90
BOU	0.24
FBK	0.56
PRU	0.22
BC	0.62
PRAIRIES	0.88
SHIELD	1.0
ATLANTIC	0.76

## References

---

- [1] *High-Impact, Low-Frequency Event Risk to the North American Bulk Power System*, A Jointly-Commissioned Summary Report of the North American Reliability Corporation and the U.S. Department of Energy's November 2009 Workshop.
- [2] Application Guide: Computing Geomagnetically-Induced Current in the Bulk-Power System, NERC. NERC.  
[http://www.nerc.com/comm/PC/Geomagnetic%20Disturbance%20Task%20Force%20GMDTF%202013/GIC%20Application%20Guide%202013\\_approved.pdf](http://www.nerc.com/comm/PC/Geomagnetic%20Disturbance%20Task%20Force%20GMDTF%202013/GIC%20Application%20Guide%202013_approved.pdf)
- [3] Kuan Zheng, Risto Pirjola, David Boteler, Lian-guang Liu, "Gеоelectric Fields Due to Small-Scale and Large-Scale Source Currents", *IEEE Transactions on Power Delivery*, Vol. 28, No. 1, January 2013, pp. 442-449.
- [4] Boteler, D. H. "Geomagnetically Induced Currents: Present Knowledge and Future Research", *IEEE Transactions on Power Delivery*, Vol. 9, No. 1, January 1994, pp. 50-58.
- [5] Boteler, D. H. "Modeling Geomagnetically Induced Currents Produced by Realistic and Uniform Electric Fields", *IEEE Transactions on Power Delivery*, Vol. 13, No. 4, January 1998, pp. 1303-1308.
- [6] J. L. Gilbert, W. A. Radasky, E. B. Savage, "A Technique for Calculating the Currents Induced by Geomagnetic Storms on Large High Voltage Power Grids", Electromagnetic Compatibility (EMC), 2012 IEEE International Symposium on.
- [7] *How to Calculate Electric Fields to Determine Geomagnetically-Induced Currents*. EPRI, Palo Alto, CA: 2013. 3002002149.
- [8] Pulkkinen, A., R. Pirjola, and A. Viljanen, Statistics of extreme geomagnetically induced current events, *Space Weather*, 6, S07001, doi:10.1029/2008SW000388, 2008.
- [9] Boteler, D. H., Assessment of geomagnetic hazard to power systems in Canada, *Nat. Hazards*, 23, 101–120, 2001.
- [10] Finnish Meteorological Institute's IMAGE magnetometer chain data available at:  
<http://image.gsfc.nasa.gov/>
- [11] Boteler, D. H., and R. J. Pirjola, The complex-image method for calculating the magnetic and electric fields produced at the surface of the Earth by the auroral electrojet, *Geophys. J. Int.*, 132(1), 31–40, 1998
- [12] Coles, Stuart (2001). *An Introduction to Statistical Modelling of Extreme Values*. Springer.
- [13] Pulkkinen, A., A. Thomson, E. Clarke, and A. McKay, April 2000 geomagnetic storm: ionospheric drivers of large geomagnetically induced currents, *Annales Geophysicae*, 21, 709-717, 2003.
- [14] Pulkkinen, A., S. Lindahl, A. Viljanen, and R. Pirjola, Geomagnetic storm of 29–31 October 2003: Geomagnetically induced currents and their relation to problems in the Swedish high-voltage power transmission system, *Space Weather*, 3, S08C03, doi:10.1029/2004SW000123, 2005.

- [15] Pulkkinen, A., E. Bernabeu, J. Eichner, C. Beggan and A. Thomson, Generation of 100-year geomagnetically induced current scenarios, *Space Weather*, Vol. 10, S04003, doi:10.1029/2011SW000750, 2012.
- [16] Ngwira, C., A. Pulkkinen, F. Wilder, and G. Crowley, Extended study of extreme geoelectric field event scenarios for geomagnetically induced current applications, *Space Weather*, Vol. 11, 121–131, doi:10.1002/swe.20021, 2013.
- [17] Thomson, A., S. Reay, and E. Dawson. Quantifying extreme behavior in geomagnetic activity, *Space Weather*, 9, S10001, doi:10.1029/2011SW000696, 2011.

# Screening Criterion for Transformer Thermal Impact Assessment

Project 2013-03 (Geomagnetic Disturbance Mitigation)

TPL-007-2 Transmission System Planned Performance for Geomagnetic Disturbance Events

## Summary

Proposed TPL-007-2 includes requirements for entities to perform two types of GMD Vulnerability Assessments to evaluate the potential impacts of GMD events on the Bulk Electric System (BES):

- The benchmark GMD Vulnerability Assessment is based on the benchmark GMD event associated with TPL-007-1 which was approved by the Federal Energy Regulatory Commission (FERC) in Order No. 830 in September 2016. The benchmark GMD event is derived from spatially-averaged geoelectric field values to address potential wide-area effects that could be caused by a severe 1-in-100 year GMD event.<sup>1</sup>
- The supplemental GMD Vulnerability Assessment, based on the supplemental GMD event, is used by entities to evaluate risks that localized peaks in geomagnetic field during a severe GMD event "could potentially affect the reliable operation of the Bulk-Power System".<sup>2</sup> Localized enhancements of geomagnetic field can result in geoelectric field values above the spatially-averaged benchmark in a local area.

The standard requires transformer thermal impact assessments to be performed on BES power transformers with high side, wye-grounded windings with terminal voltage greater than 200 kV. Identified BES transformers must undergo a thermal impact assessment if the maximum effective geomagnetically-induced current (GIC) in the transformer is equal to or greater than:

- 75 A per phase for the benchmark GMD event
- 85 A per phase for the supplemental GMD event

Based on published power transformer measurement data as described below, the respective screening criteria are conservative and, although derived from measurements in single-phase units, are applicable to transformers with all core types (e.g., three-limb, three-phase).

---

<sup>1</sup> See *Benchmark Geomagnetic Disturbance Event Description* white paper, May 12, 2016. Filed by NERC in RM15-11 on June 28, 2016.

<sup>2</sup> See Order No. 830 P. 47. On September 22, 2016, FERC directed NERC to develop modifications to the benchmark GMD event, included in TPL-007-1, such that assessments would not be based solely on spatially averaged data. The characteristics of a GMD event for this assessment are in the Supplemental GMD Event Description white paper.

Outside of the differing screening criteria, the only difference between the thermal impact assessment for the benchmark GMD event and the supplemental GMD event is that a different waveform is used, therefore peak metallic hot spot temperatures are slightly different for a given GIC in the transformer.

### Justification for the Benchmark Screening Criterion

Applicable entities are required to carry out a thermal assessment with GIC(t) calculated using the benchmark GMD event geomagnetic field time series or waveform for effective GIC values above a screening threshold. The calculated GIC(t) for every transformer will be different because the length and orientation of transmission circuits connected to each transformer will be different even if the geoelectric field is assumed to be uniform. However, for a given thermal model and maximum effective GIC there are upper and lower bounds for the peak hot spot temperatures. These are shown in **Figure 1** using three available thermal models based on direct temperature measurements.

The results shown in **Figure 1** summarize the peak metallic hot spot temperatures when GIC(t) is calculated using (1), and systematically varying GIC<sub>E</sub> and GIC<sub>N</sub> to account for all possible orientation of circuits connected to a transformer. The transformer GIC (in A/phase) for any value of E<sub>E</sub>(t) and E<sub>N</sub>(t) can be calculated using equation (1) from reference [1].

$$GIC(t) = |E(t)| \cdot \{GIC_E \sin(\varphi(t)) + GIC_N \cos(\varphi(t))\} \quad (1)$$

where

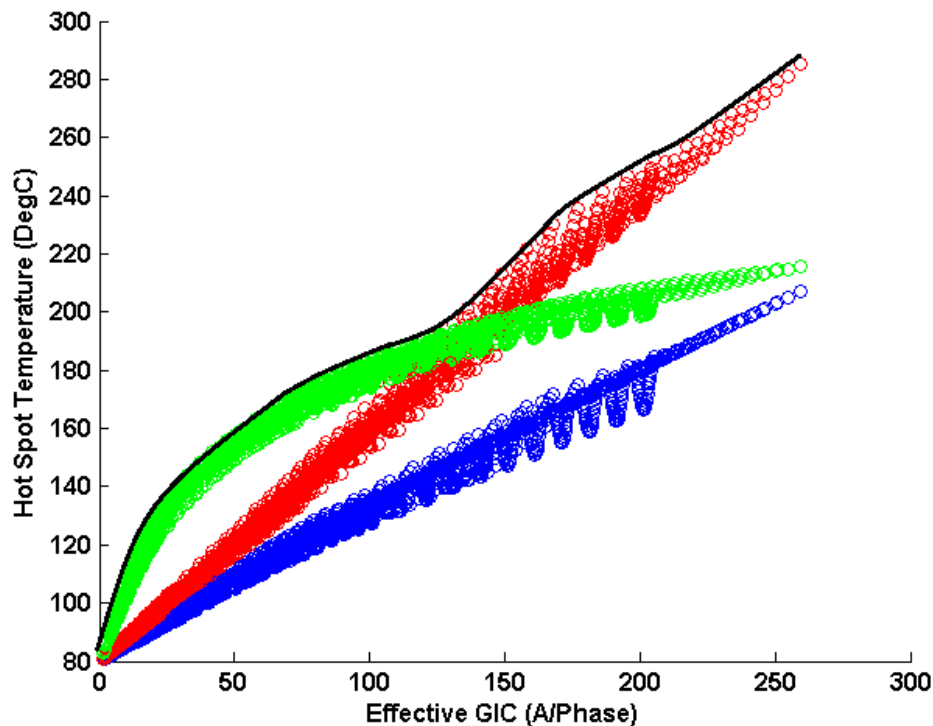
$$|E(t)| = \sqrt{E_N^2(t) + E_E^2(t)} \quad (2)$$

$$\varphi(t) = \tan^{-1}\left(\frac{E_E(t)}{E_N(t)}\right) \quad (3)$$

$$GIC(t) = E_E(t) \cdot GIC_E + E_N(t) \cdot GIC_N \quad (4)$$

GIC<sub>N</sub> is the effective GIC due to a northward geoelectric field of 1 V/km, and GIC<sub>E</sub> is the effective GIC due to an eastward geoelectric field of 1 V/km. The units for GIC<sub>N</sub> and GIC<sub>E</sub> are A/phase per V/km.

It should be emphasized that with the thermal models used and the benchmark GMD event geomagnetic field waveform, peak metallic hot spot temperatures will lie below the envelope shown in black in **Figure 1**. The x-axis in **Figure 1** corresponds to the absolute value of peak GIC(t). Effective maximum GIC for a transformer corresponds to a worst-case geoelectric field orientation, which is network-specific. **Figure 1** represents a possible range, not the specific thermal response for a given effective GIC and orientation.



**Figure 1: Metallic hot spot temperatures calculated using the benchmark GMD event.**

Red: SVC coupling transformer model [2]. Blue: Fingrid model [3]. Green: Autotransformer model [4].

Consequently, with the most conservative thermal models known at this point in time, the peak metallic hot spot temperature obtained with the benchmark GMD event waveform assuming an effective GIC magnitude of 75 A per phase will result in a peak temperature between 160°C and 172°C when the bulk oil temperature is 80°C (full load bulk oil temperature). The upper boundary of 172°C remains well below the metallic hot spot 200°C threshold for short-time emergency loading suggested in IEEE Std C57.91-2011 – Guide for Loading Mineral-Oil-Immersed Transformers and Step-Voltage Regulators [5].

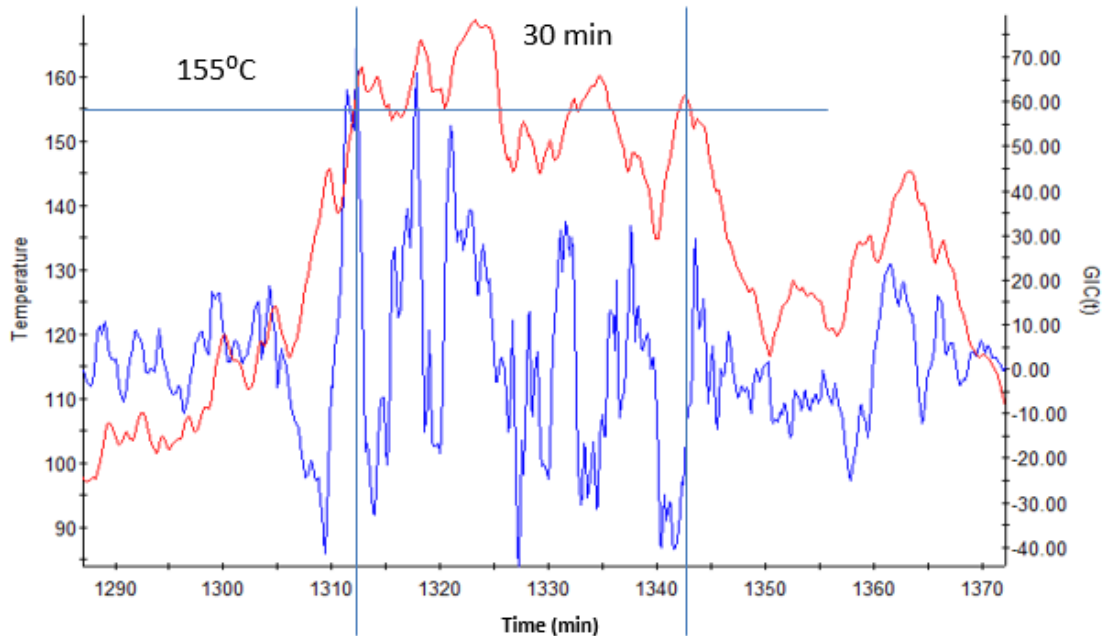
The selection of the 75 A per phase screening threshold is based on the following considerations:

- A thermal assessment, which uses the most conservative thermal models known to date, indicates that a GIC of 75A will not result in peak metallic hot spot temperatures above 172°C. Transformer thermal assessments should not be required by Reliability Standards when results will fall well below IEEE Std C57.91-2011 limits.
- Applicable entities may choose to carry out a thermal assessment when the effective GIC is below 75 A per phase to take into account the age or condition of specific transformers where IEEE Std C57.91- 2011 limits could be assumed to be lower than 200°C. Refer to IEEE Standard C57.163-2015

Guide for Establishing Power Transformer Capability while under Geomagnetic Disturbances for additional information [6].

- The models used to determine the 75 A per phase screening threshold are known to be conservative at higher values of effective GIC, especially the SVC coupling transformer model in [2].
- Thermal models in peer-reviewed technical literature, especially those calculated models without experimental validation, are less conservative than the models used to determine the screening threshold. Therefore, a technically-justified thermal assessment for effective GIC below 75 A per phase using the benchmark GMD event geomagnetic field waveform will always result in a “pass” on the basis of the state of the knowledge at this point in time.
- Based on simulations, the 75 A per phase screening threshold will result in a maximum instantaneous peak hot spot temperature of 172°C. However, IEEE Std C57.91- 2011 limits assume short term emergency operation (typically 30 minutes). As illustrated in **Figure 2**, simulations of the 75 A per phase screening threshold result in 30-minute duration hot spot temperatures of about 155°C. The threshold provides an added measure of conservatism in not taking into account the duration of hot spot temperatures.
- The models used in the determination of the threshold are conservative but technically justified.
- Winding hot spots are not the limiting factor in terms of hot spots due to half-cycle saturation, therefore the screening criterion is focused on metallic part hot spots only.

The 75 A per phase screening threshold was determined using single-phase transformers, but is being applied as a screening criterion for all types of transformer construction. While it is known that some transformer types such as three-limb, three-phase transformers are intrinsically less susceptible to GIC, it is not known by how much, on the basis of experimentally-supported models.



**Figure 2: Metallic hot spot temperatures calculated using the benchmark GMD event.**  
 Red: metallic hot spot temperature. Blue: GIC(t) that produces the maximum hot spot temperature with peak GIC(t) scaled to 75 A/phase.

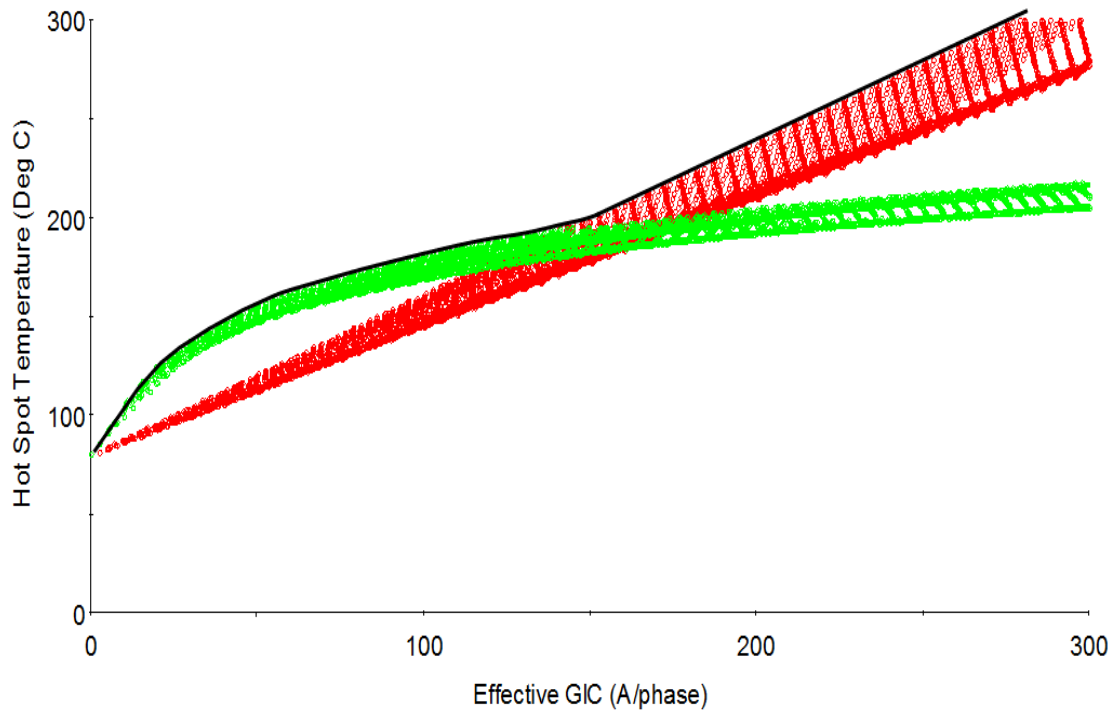
## Justification for the Supplemental Screening Criterion

As in the case for the benchmark GMD event discussed above, applicable entities are required to carry out thermal assessments on their BES power transformers when the effective GIC values are above a screening threshold. GIC(t) for supplemental thermal assessments is calculated using the supplemental GMD event geomagnetic field time series or waveform.

Using the supplemental GMD event waveform, a thermal analysis was completed for the two transformers that were limiting for the benchmark waveform. The results are shown in **Figure 3**. Peak metallic hot spot temperatures for the supplemental GMD event will lie below the envelope shown by the black line trace in **Figure 3**. Because the supplemental waveform has a sharper peak, the peak metallic hot spot temperatures are slightly lower than those associated with the benchmark waveform. Applying the most conservative thermal models known at this point in time, the peak metallic hot spot temperature obtained with the supplemental GMD event waveform assuming an effective GIC magnitude of 85 A per phase will result in a peak temperature of 172°C when the bulk oil temperature is 80°C (full load bulk oil temperature).<sup>3</sup> Thus, 85 A per phase is the screening level for the supplemental waveform.

<sup>3</sup> The temperature 172°C was selected as the screening criteria for the benchmark waveform as described in the preceding section.





**Figure 3: Metallic hot spot temperatures calculated using the supplemental GMD event.**  
Green: SVC coupling transformer model [2]. Red: Autotransformer model [4]

## Appendix I - Transformer Thermal Models Used in the Development of the Screening Criteria

The envelope used for thermal screening (**Figure 1**) is derived from two thermal models. The first is based on laboratory measurements carried out on 500/16.5 kV 400 MVA single-phase Static Var Compensator (SVC) coupling transformer [2]. Temperature measurements were carried out at relatively small values of GIC (see **Figure I-1**). The asymptotic thermal response for this model is the linear extrapolation of the known measurement values. Although the near-linear behavior of the asymptotic thermal response is consistent with the measurements made on a Fingrid 400 kV 400 MVA five-leg core-type fully-wound transformer [3] (see **Figures I-2 and I-3**), the extrapolation from low values of GIC is very conservative, but reasonable for screening purposes.

The second transformer model is based on a combination of measurements and modeling for a 400 kV 400 MVA single-phase core-type autotransformer [4] (see **Figures I-4 and I-5**). The asymptotic thermal behavior of this transformer shows a “down-turn” at high values of GIC as the tie plate increasingly saturates but relatively high temperatures for lower values of GIC. The hot spot temperatures are higher than for the two other models for GIC less than 125 A per phase.

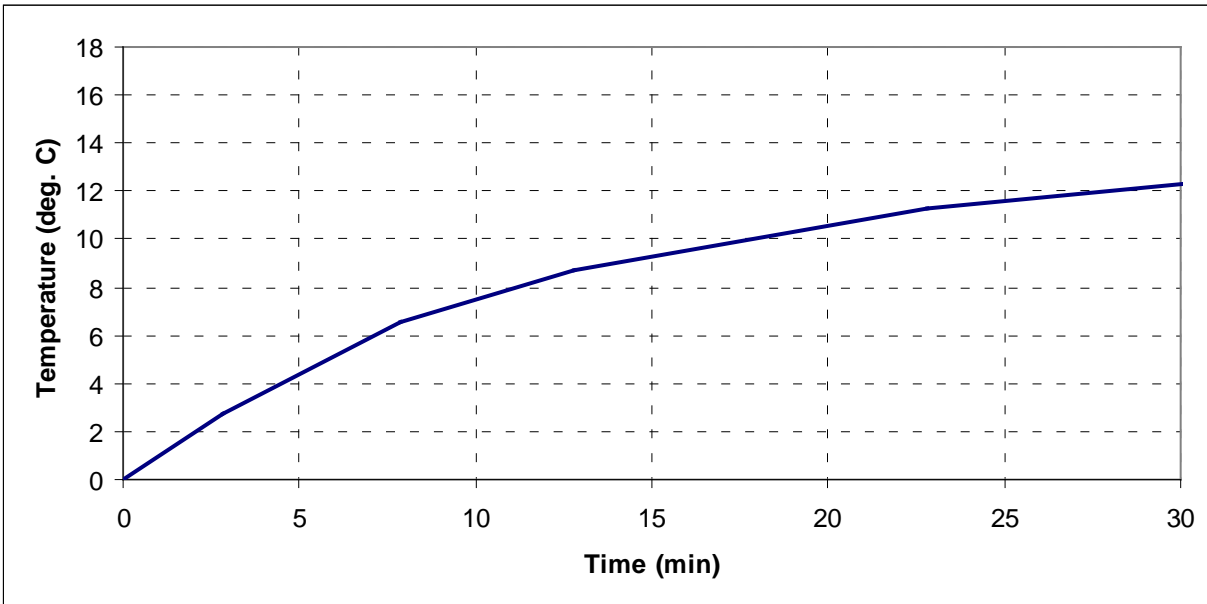


Figure I-1: Thermal step response of the tie plate of a 500 kV 400 MVA single-phase SVC coupling transformer to a 5 A per phase dc step.

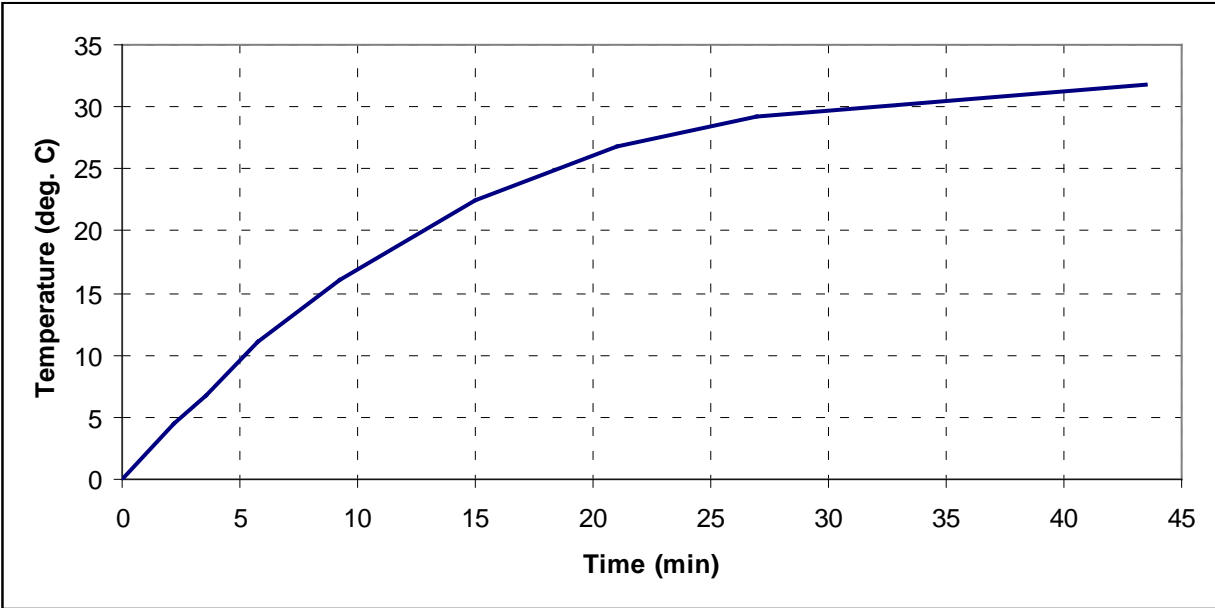


Figure I-2: Step thermal response of the top yoke clamp of a 400 kV 400 MVA five-leg core-type fully-wound transformer to a 16.67 A per phase dc step.

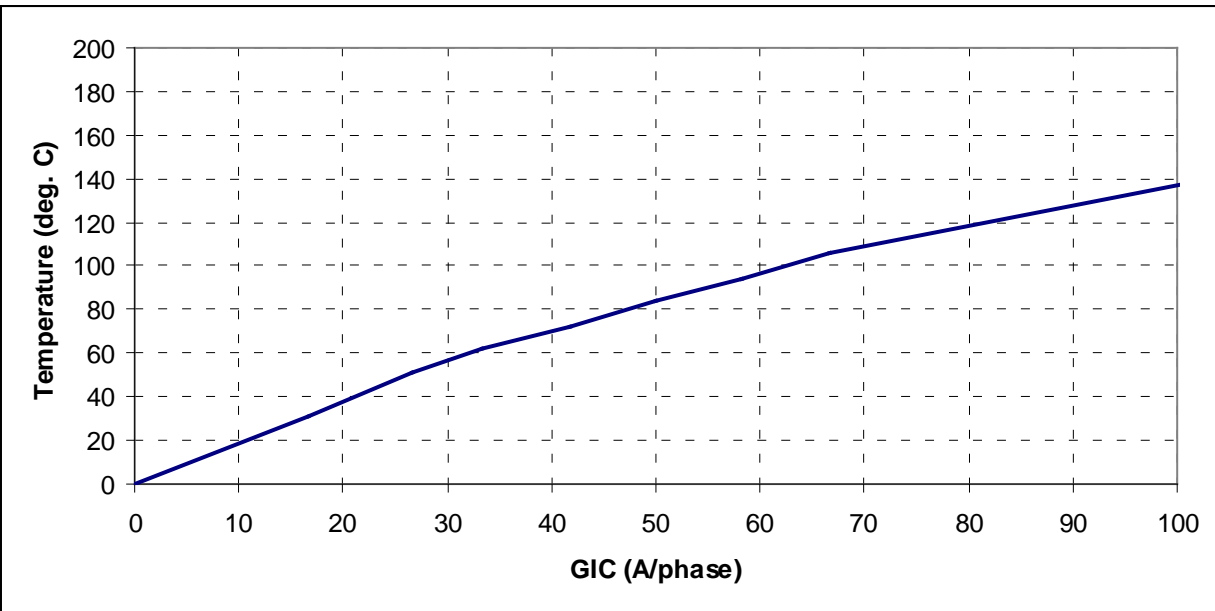


Figure I-3: Asymptotic thermal response of the top yoke clamp of a 400 kV 400 MVA five-leg core-type fully-wound transformer.

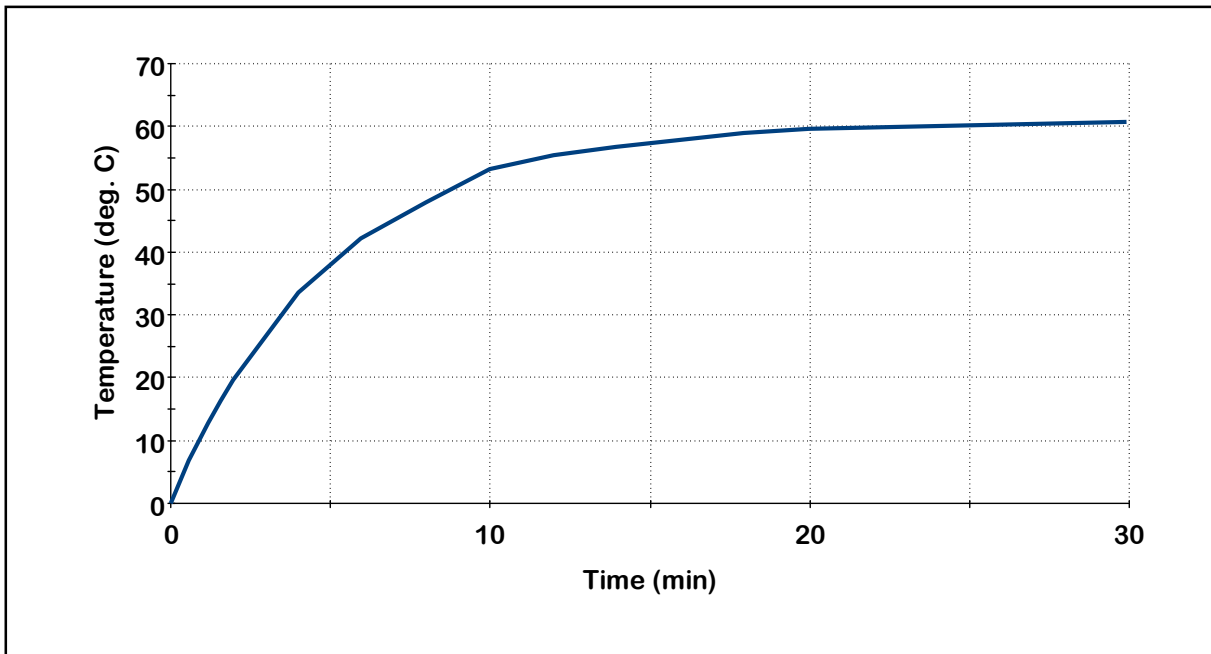


Figure I-4: Step thermal response of the tie plate of a 400 kV 400 MVA single-phase core-type autotransformer to a 10 A per phase dc step.

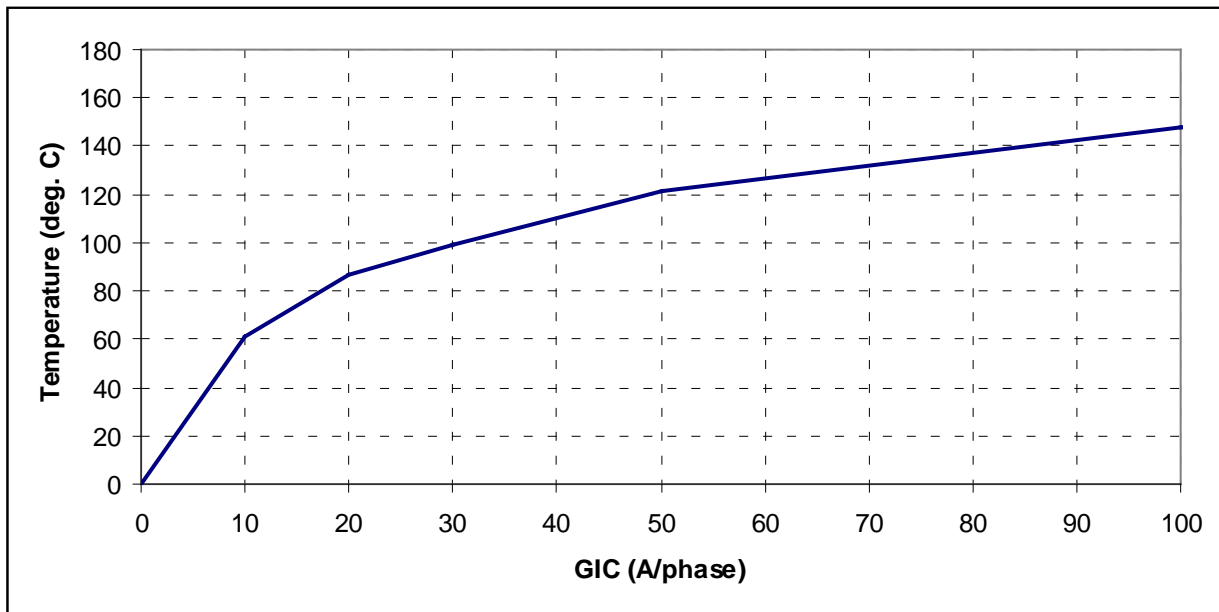


Figure I-5: Asymptotic thermal response of the tie plate of a 400 kV 400 MVA single-phase core-type autotransformer.

The envelope in **Figure 1** can be used as a conservative thermal assessment for effective GIC values of associated with the benchmark waveform (see **Table 1**).

Effective GIC (A/phase)	Metallic hot spot Temperature (°C)	Effective GIC (A/phase)	Metallic hot spot Temperature (°C)
0	80	100	182
10	107	110	186
20	128	120	190
30	139	130	193
40	148	140	204
50	157	150	213
60	169	160	221
70	170	170	230
75	172	180	234
80	175	190	241
90	179	200	247

For instance, if effective GIC is 130 A per phase and oil temperature is assumed to be 80°C, peak hot spot temperature is 193°C. This value is below the 200°C IEEE Std C57.91-2011 threshold for short time emergency loading and this transformer will have passed the thermal assessment. If the full heat run oil temperature is 67°C at maximum ambient temperature, then 150 A per phase of effective GIC translates into a peak hot spot temperature of 200°C and the transformer will have passed. If the limit is lowered to 180°C to account for the condition of the transformer, then this would be an indication to “sharpen the pencil” and perform a detailed assessment. Some methods are described in Reference [1].

The temperature envelope in **Figure 1** corresponds to the values of effective GIC that result in the highest temperature for the benchmark GMD event. Different values of effective GIC could result in lower temperatures using the same model. For instance, the difference in upper and lower bounds of peak temperatures for the SVC coupling transformer model for 150 A per phase is approximately 30°C. In this case, GIC(t) should be generated to calculate the peak temperatures for the actual configuration of the transformer within the system as described in Reference [1]. Alternatively, a more precise thermal assessment could be carried out with a thermal model that more closely represents the thermal behavior of the transformer under consideration.

Similar to the discussion above, the envelope in **Figure 3** can be used as a conservative thermal assessment for effective GIC values of associated with the supplemental waveform (see **Table 2**). Because the supplemental waveform has a sharper peak, the peak metallic hot spot temperatures associated with

the supplemental waveform are slightly lower than those associated with the benchmark waveform. Comparing **Tables 1 and 2** shows the magnitude of this difference.

**Table 2: Upper Bound of Peak Metallic Hot Spot Temperatures Calculated Using the Supplemental GMD Event**

Effective GIC (A/phase)	Metallic hot spot Temperature (°C)	Effective GIC(A/phase)	Metallic hot spot Temperature (°C)
0	80	120	188
10	107	130	191
20	124	140	194
30	137	150	198
40	147	160	203
50	156	170	209
60	161	180	214
70	162	190	229
75	165	200	237
80	169	220	248
85	172	230	253
90	177	250	276
100	181	275	298
110	185	300	316

## References

- [1] Transformer Thermal Impact Assessment white paper. Developed by the Project 2013-03 (Geomagnetic Disturbance) standard drafting team. Available at: <http://www.nerc.com/pa/stand/Pages/TPL0071RI.aspx>
- [2] Marti, L., Rezaei-Zare, A., Narang, A., "Simulation of Transformer Hotspot Heating due to Geomagnetically Induced Currents," *IEEE Transactions on Power Delivery*, vol.28, no.1, pp.320-327, Jan. 2013.
- [3] Lahtinen, Matti. Jarmo Elovaara. "GIC occurrences and GIC test for 400 kV system transformer". *IEEE Transactions on Power Delivery*, Vol. 17, No. 2. April 2002.
- [4] J. Raith, S. Ausserhofer: "GIC Strength verification of Power Transformers in a High Voltage Laboratory", GIC Workshop, Cape Town, April 2014
- [5] "IEEE Guide for Loading Mineral-Oil-Immersed Transformers and Step-Voltage Regulators." IEEE Std C57.91-2011 (Revision of IEEE Std C57.91-1995).
- [6] "IEEE Guide for Establishing Power Transformer Capability while under Geomagnetic Disturbances." IEEE Std C57.163-2015.

# Screening Criterion for Transformer Thermal Impact Assessment

Project 2013-03 (Geomagnetic Disturbance Mitigation)

TPL-007-~~4~~2 Transmission System Planned Performance for Geomagnetic Disturbance Events

## Summary

~~Proposed standard TPL-007-1 — Transmission System Planned Performance for Geomagnetic Disturbance Events requires applicable entities to conduct assessments of the potential impact of benchmark GMD events on their systems. The standard requires transformer thermal impact assessments to be performed on power transformers with high side, wye-grounded windings with terminal voltage greater than 200 kV. Transformers are exempt from the thermal impact assessment requirement if the maximum effective geomagnetically induced current (GIC) in the transformer is less than 75 A per phase as determined by GIC analysis of the system. Based on published power transformer measurement data as described below, an effective GIC of 75 A per phase is a conservative screening criterion. To provide an added measure of conservatism, the 75 A per phase threshold, although derived from measurements in single-phase units, is applicable to transformers with all core types (e.g., three-limb, three-phase).~~

Proposed TPL-007-2 includes requirements for entities to perform two types of GMD Vulnerability Assessments to evaluate the potential impacts of GMD events on the Bulk Electric System (BES):

- The benchmark GMD Vulnerability Assessment is based on the benchmark GMD event associated with TPL-007-1 which was approved by the Federal Energy Regulatory Commission (FERC) in Order No. 830 in September 2016. The benchmark GMD event is derived from spatially-averaged geoelectric field values to address potential wide-area effects that could be caused by a severe 1-in-100 year GMD event.<sup>1</sup>
- The supplemental GMD Vulnerability Assessment, based on the supplemental GMD event, is used by entities to evaluate risks that localized peaks in geomagnetic field during a severe GMD event "could potentially affect the reliable operation of the Bulk-Power System".<sup>2</sup> Localized enhancements of geomagnetic field can result in geoelectric field values above the spatially-averaged benchmark in a local area.

<sup>1</sup> See Benchmark Geomagnetic Disturbance Event Description white paper, May 12, 2016. Filed by NERC in RM15-11 on June 28, 2016.

<sup>2</sup> See Order No. 830 P. 47. On September 22, 2016, FERC directed NERC to develop modifications to the benchmark GMD event, included in TPL-007-1, such that assessments would not be based solely on spatially averaged data. The characteristics of a GMD event for this assessment are in the Supplemental GMD Event Description white paper.



The standard requires transformer thermal impact assessments to be performed on BES power transformers with high side, wye-grounded windings with terminal voltage greater than 200 kV. Identified BES transformers must undergo a thermal impact assessment if the maximum effective geomagnetically-induced current (GIC) in the transformer is equal to or greater than:

- 75 A per phase for the benchmark GMD event
- 85 A per phase for the supplemental GMD event

Based on published power transformer measurement data as described below, the respective screening criteria are conservative and, although derived from measurements in single-phase units, are applicable to transformers with all core types (e.g., three-limb, three-phase).

Outside of the differing screening criteria, the only difference between the thermal impact assessment for the benchmark GMD event and the supplemental GMD event is that a different waveform is used, therefore peak metallic hot spot temperatures are slightly different for a given GIC in the transformer.

### **Justification for the Benchmark Screening Criterion**

Applicable entities are required to carry out a thermal assessment with GIC(t) calculated using the benchmark GMD event geomagnetic field time series or [wvaveshapewaveform](#) for effective GIC values above a screening threshold. The calculated GIC(t) for every transformer will be different because the length and orientation of transmission circuits connected to each transformer will be different even if the geoelectric field is assumed to be uniform. However, for a given thermal model and maximum effective GIC there are upper and lower bounds for the peak hot spot temperatures. These are shown in **Figure 1** using three available thermal models based on direct temperature measurements.

The results shown in **Figure 1** summarize the peak metallic hot spot temperatures when GIC(t) is calculated using (1), and systematically varying GIC<sub>E</sub> and GIC<sub>N</sub> to account for all possible orientation of circuits connected to a transformer. The transformer GIC (in A/phase) for any value of E<sub>E</sub>(t) and E<sub>N</sub>(t) can be calculated using equation (1) from reference [1].

$$GIC(t) = |E(t)| \cdot \{GIC_E \sin(\varphi(t)) + GIC_N \cos(\varphi(t))\} \quad (1)$$

where

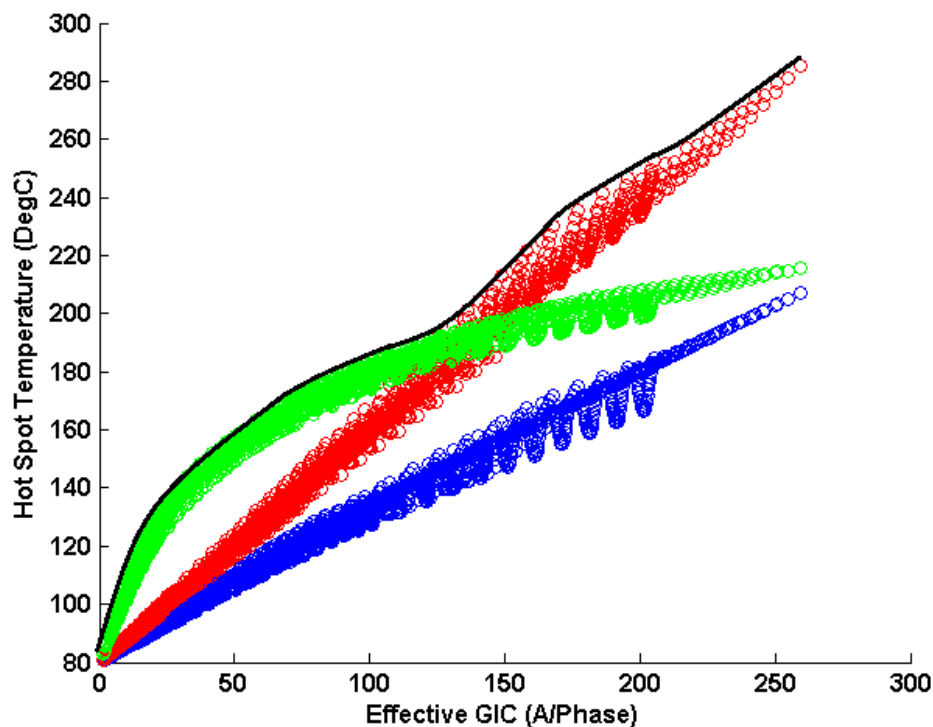
$$|E(t)| = \sqrt{E_N^2(t) + E_E^2(t)} \quad (2)$$

$$\varphi(t) = \tan^{-1} \left( \frac{E_E(t)}{E_N(t)} \right) \quad (3)$$

$$GIC(t) = E_E(t) \cdot GIC_E + E_N(t) \cdot GIC_N \quad (4)$$

$GIC_N$  is the effective GIC due to a northward geoelectric field of 1 V/km, and  $GIC_E$  is the effective GIC due to an eastward geoelectric field of 1 V/km. The units for  $GIC_N$  and  $GIC_E$  are A/phase/phase/V/km.

It should be emphasized that with the thermal models used and the benchmark GMD event geomagnetic field [wavenamewaveform](#), peak [metallic](#) hot spot temperatures [mustwill](#) lie below the envelope shown in [black in Figure 1](#). The x-axis in [Figure 1](#) corresponds to the absolute value of peak  $GIC(t)$ . Effective maximum GIC for a transformer corresponds to a worst-case geoelectric field orientation, which is network-specific. [Figure 1](#) represents a possible range, not the specific thermal response for a given effective GIC and orientation.



**Figure 1: Metallic hot spot temperatures calculated using the benchmark GMD event.** ~~Red: SVC coupling transformer model [2]. Blue: Fingrid model [3]. Green: Autotransformer model [4].~~  
 Red: SVC coupling transformer model [2]. Blue: Fingrid model [3]. Green: Autotransformer model [4].

Consequently, with the most conservative thermal models known at this point in time, the peak metallic hot spot temperature obtained with the benchmark GMD event [wavenamewaveform](#) assuming an effective GIC magnitude of 75 A per phase will result in a peak temperature between 160°C and 172°C when the bulk oil temperature is 80°C (full load bulk oil temperature). The upper boundary of 172°C remains well

below the metallic hot spot 200°C threshold for short-time emergency loading suggested in IEEE Std C57.91-2011 [5] (see Table 1). [Guide for Loading Mineral-Oil-Immersed Transformers and Step-Voltage Regulators \[5\]](#).

TABLE 1:  
Excerpt from Maximum Temperature Limits Suggested in IEEE C57.91 2011

	Normal life expectancy loading	Planned loading beyond nameplate rating	Long-time emergency loading	Short-time emergency loading
Insulated conductor hottest-spot temperature °C	120	130	140	180
Other metallic hot-spot temperature (in contact and not in contact with insulation), °C	140	150	160	200
Top-oil temperature °C	105	110	110	110

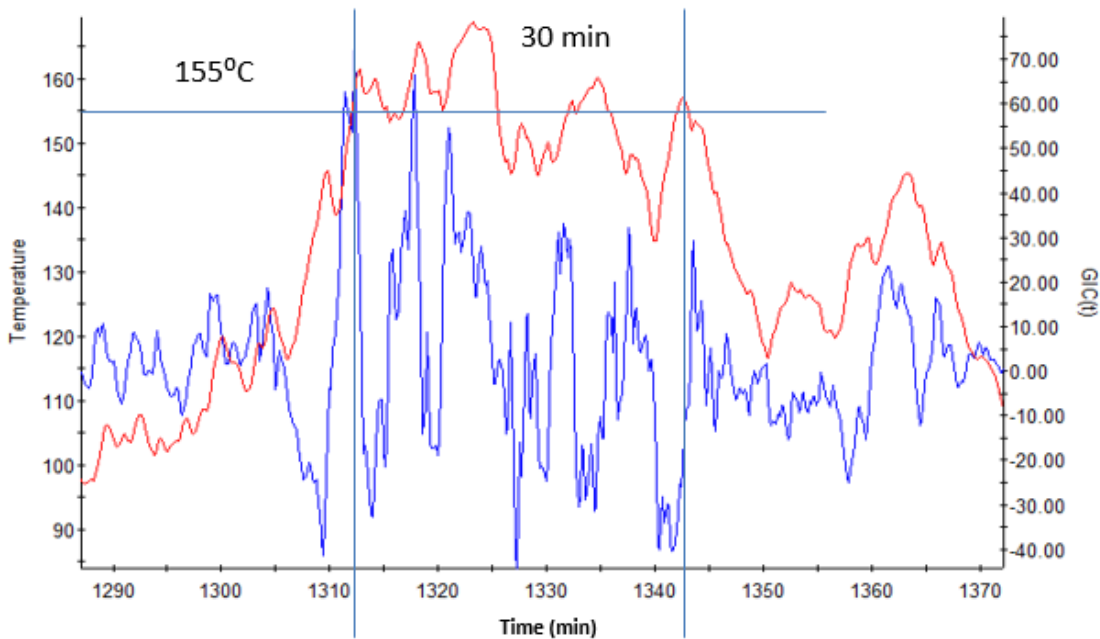
The selection of the 75 A per phase screening threshold is based on the following considerations:

- A thermal assessment [using, which uses](#) the most conservative thermal models known to date, [indicates that a GIC of 75A](#) will not result in peak [metallic](#) hot spot temperatures above 172°C. Transformer thermal assessments should not be required by Reliability Standards when results will fall well below IEEE Std C57.91-2011 limits.
- Applicable entities may choose to carry out a thermal assessment when the effective GIC is below 75 A per phase to take into account the age or condition of specific transformers where IEEE Std C57.91- 2011 limits could be assumed to be lower than 200°C. [Refer to IEEE Standard C57.163-2015 Guide for Establishing Power Transformer Capability while under Geomagnetic Disturbances for additional information \[6\]](#).
- The models used to determine the 75 A per phase screening threshold are known to be conservative at higher values of effective GIC, especially the SVC coupling transformer model in [2].
- Thermal models in peer-reviewed technical literature, especially those calculated models without experimental validation, are less conservative than the models used to determine the screening threshold. Therefore, a technically-justified thermal assessment for effective GIC below 75 A per phase using the benchmark GMD event geomagnetic field [wvaveshapewaveform](#) will always result in a “pass” on the basis of the state of the knowledge at this point in time.
- Based on simulations, the 75 A per phase screening threshold will result in a maximum instantaneous peak hot spot temperature of 172°C. However, IEEE Std C57.91- 2011 limits assume short term emergency operation (typically 30 minutes). As illustrated in **Figure 2**, simulations of the 75 A per phase screening threshold result in 30-minute duration hot spot temperatures of about

155°C. The threshold provides an added measure of conservatism in not taking into account the duration of hot spot temperatures.

- The models used in the determination of the threshold are conservative but technically justified.
- Winding hot spots are not the limiting factor in terms of hot spots due to half-cycle saturation, therefore the screening criterion is focused on metallic part hot spots only.

The 75 A per phase screening threshold was determined using single-phase transformers, but is [applicable to being applied as a screening criterion for](#) all types of transformer construction. While it is known that some transformer types such as three-limb, three-phase transformers are intrinsically less susceptible to GIC, it is not known by how much, on the basis of experimentally-supported models.



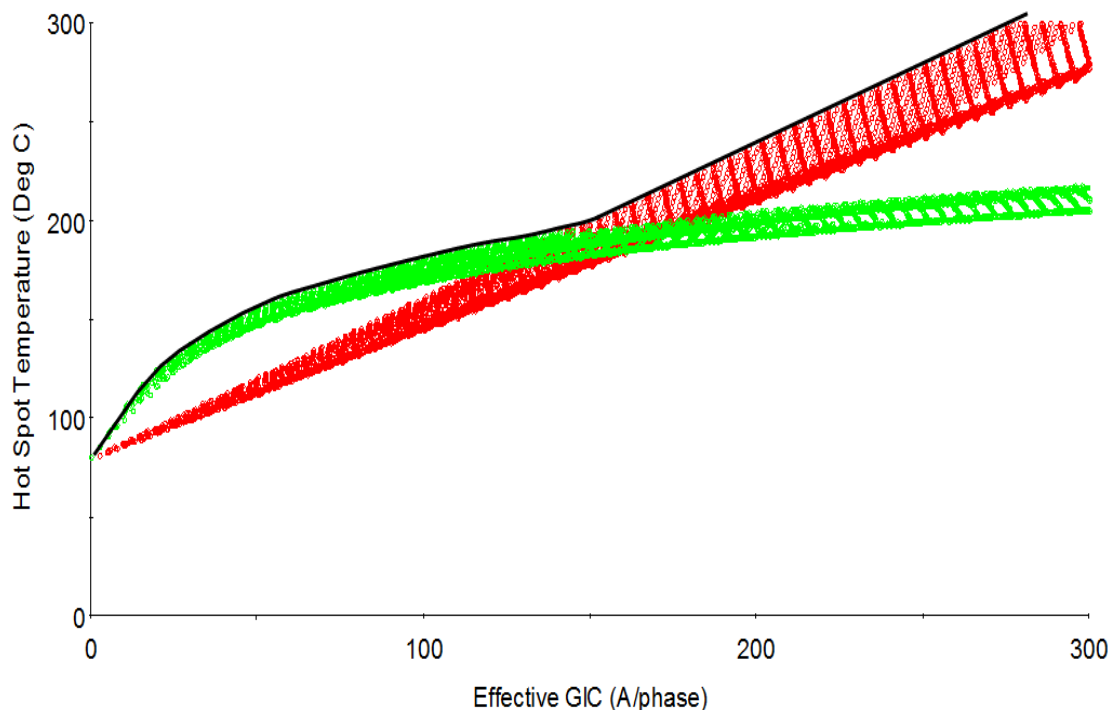
**Figure 2: Metallic hot spot temperatures calculated using the benchmark GMD event. Red: metallic hot spot temperature. Blue: GIC(t) that produces the maximum hot spot temperature with peak GIC(t) scaled to 75 A/phase.**

Red: metallic hot spot temperature. Blue: GIC(t) that produces the maximum hot spot temperature with peak GIC(t) scaled to 75 A/phase.

### [Justification for the Supplemental Screening Criterion](#)

As in the case for the benchmark GMD event discussed above, applicable entities are required to carry out thermal assessments on their BES power transformers when the effective GIC values are above a screening threshold. GIC(t) for supplemental thermal assessments is calculated using the supplemental GMD event geomagnetic field time series or waveform.

Using the supplemental GMD event waveform, a thermal analysis was completed for the two transformers that were limiting for the benchmark waveform. The results are shown in **Figure 3**. Peak metallic hot spot temperatures for the supplemental GMD event will lie below the envelope shown by the black line trace in **Figure 3**. Because the supplemental waveform has a sharper peak, the peak metallic hot spot temperatures are slightly lower than those associated with the benchmark waveform. Applying the most conservative thermal models known at this point in time, the peak metallic hot spot temperature obtained with the supplemental GMD event waveform assuming an effective GIC magnitude of 85 A per phase will result in a peak temperature of 172°C when the bulk oil temperature is 80°C (full load bulk oil temperature).<sup>3</sup> Thus, 85 A per phase is the screening level for the supplemental waveform.



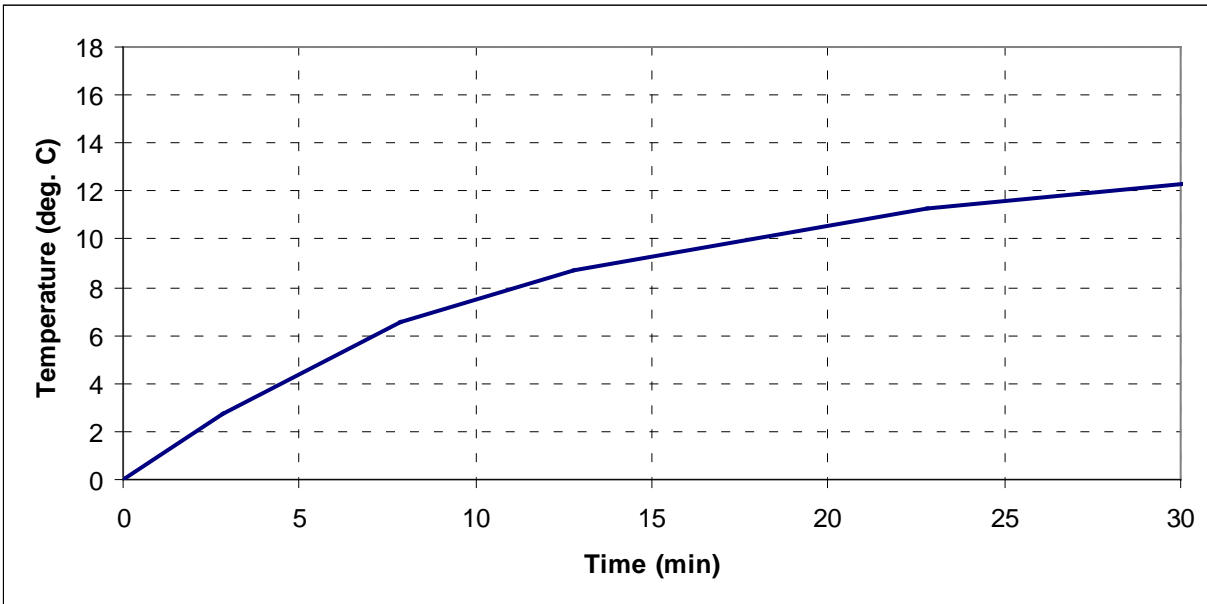
**Figure 3: Metallic hot spot temperatures calculated using the supplemental GMD event.**  
 Green: SVC coupling transformer model [2]. Red: Autotransformer model [4]

<sup>3</sup> The temperature 172°C was selected as the screening criteria for the benchmark waveform as described in the preceding section.

## Appendix I - Transformer Thermal Models Used in the Development of the Screening Criteria

The envelope used for thermal screening (**Figure 1**) is derived from two thermal models. The first is based on laboratory measurements carried out on 500/16.5 kV 400 MVA single-phase Static Var Compensator (SVC) coupling transformer [2]. Temperature measurements were carried out at relatively small values of GIC (see **Figure 3I-1**). The asymptotic thermal response for this model is the linear extrapolation of the known measurement values. Although the near-linear behavior of the asymptotic thermal response is consistent with the measurements made on a Fingrid 400 kV 400 MVA five-leg core-type fully-wound transformer [3] (see **Figures 4I-2 and 5I-3**), the extrapolation from low values of GIC is very conservative, but reasonable for screening purposes.

The second transformer model is based on a combination of measurements and modeling for a 400 kV 400 MVA single-phase core-type autotransformer [4] (see **Figures 6I-4 and 7I-5**). The asymptotic thermal behavior of this transformer shows a “down-turn” at high values of GIC as the tie plate increasingly saturates but relatively high temperatures for lower values of GIC. The hot spot temperatures are higher than for the two other models for GIC less than 125 A per phase.



**Figure 3I-1:** Thermal step response of the tie plate of a 500 kV 400 MVA single-phase SVC coupling transformer to a 5 A per phase dc step.

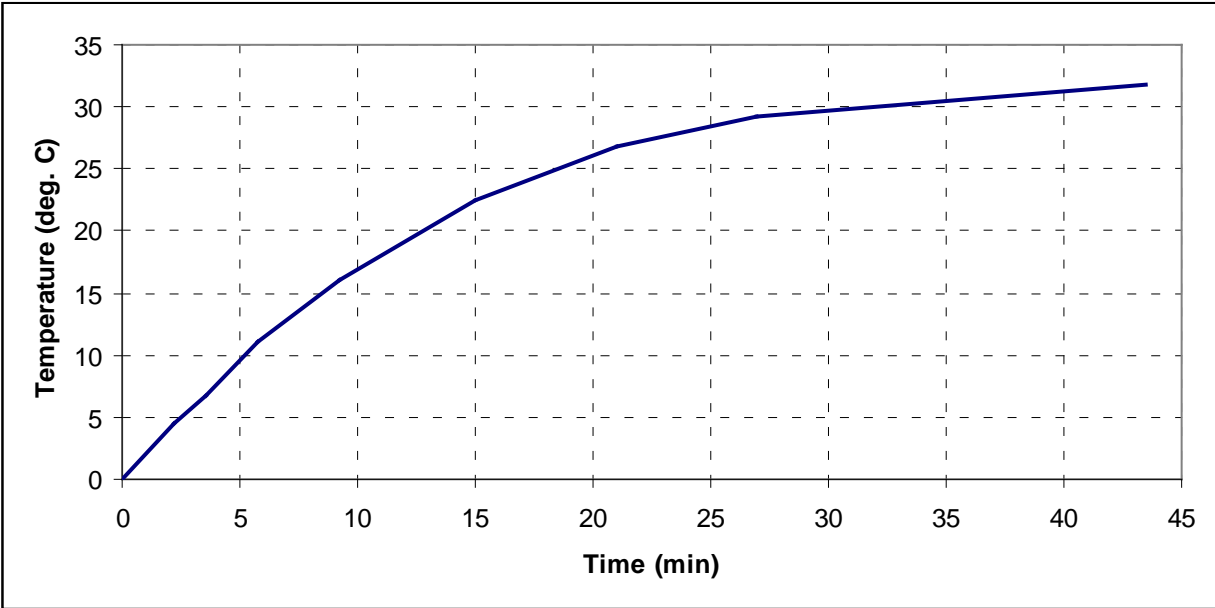


Figure 4I-2: Step thermal response of the top yoke clamp of a 400 kV 400 MVA five-leg core-type fully-wound transformer to a 16.67 A per phase dc step.

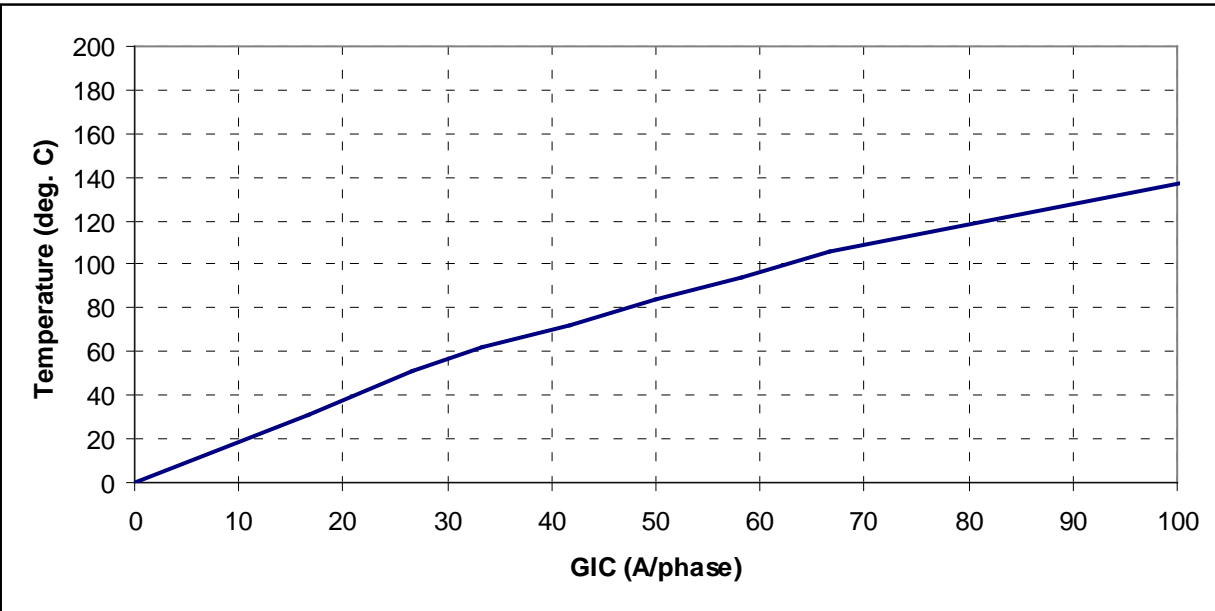


Figure 5-I-3: Asymptotic thermal response of the top yoke clamp of a 400 kV 400 MVA five-leg core-type fully-wound transformer.

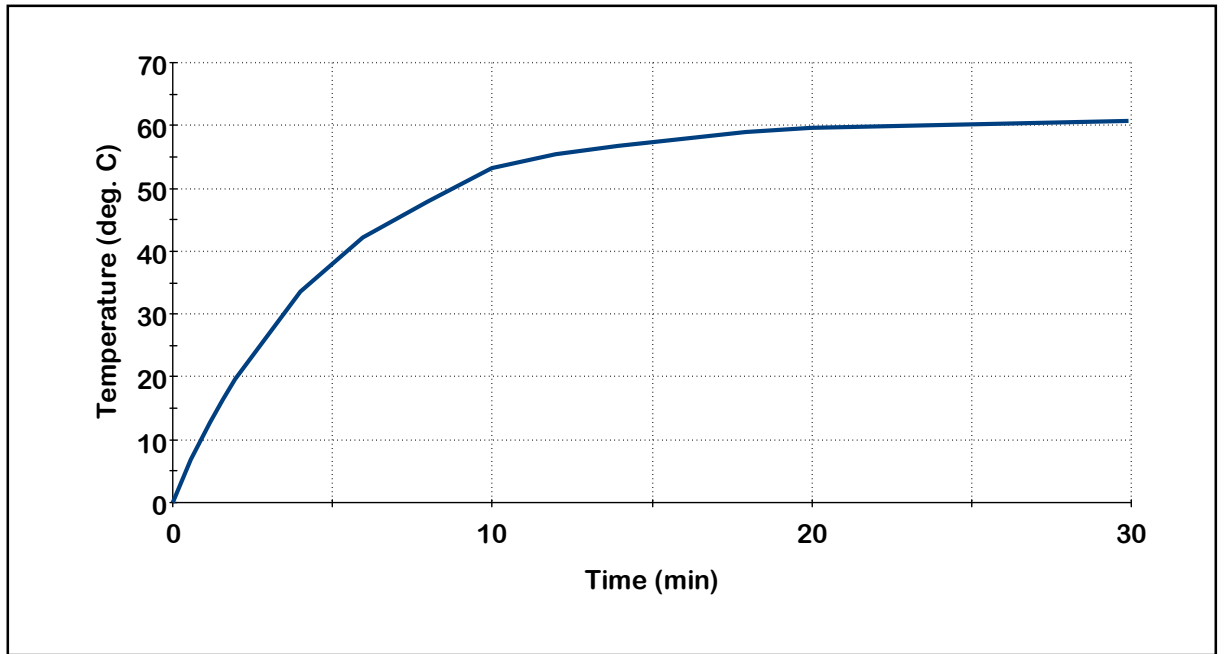
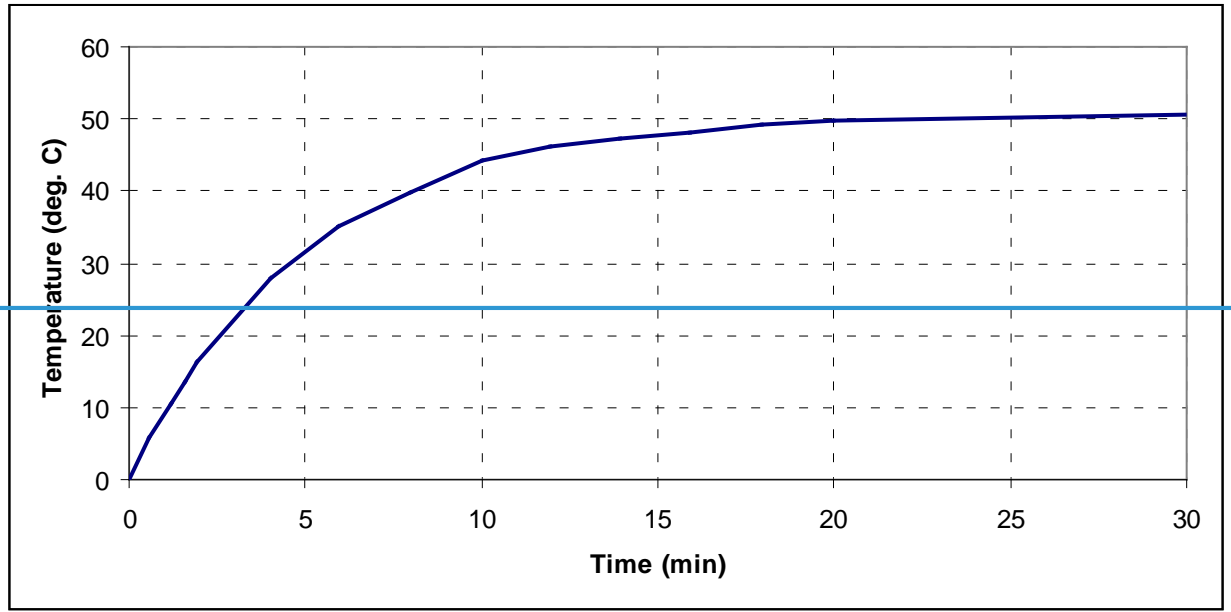
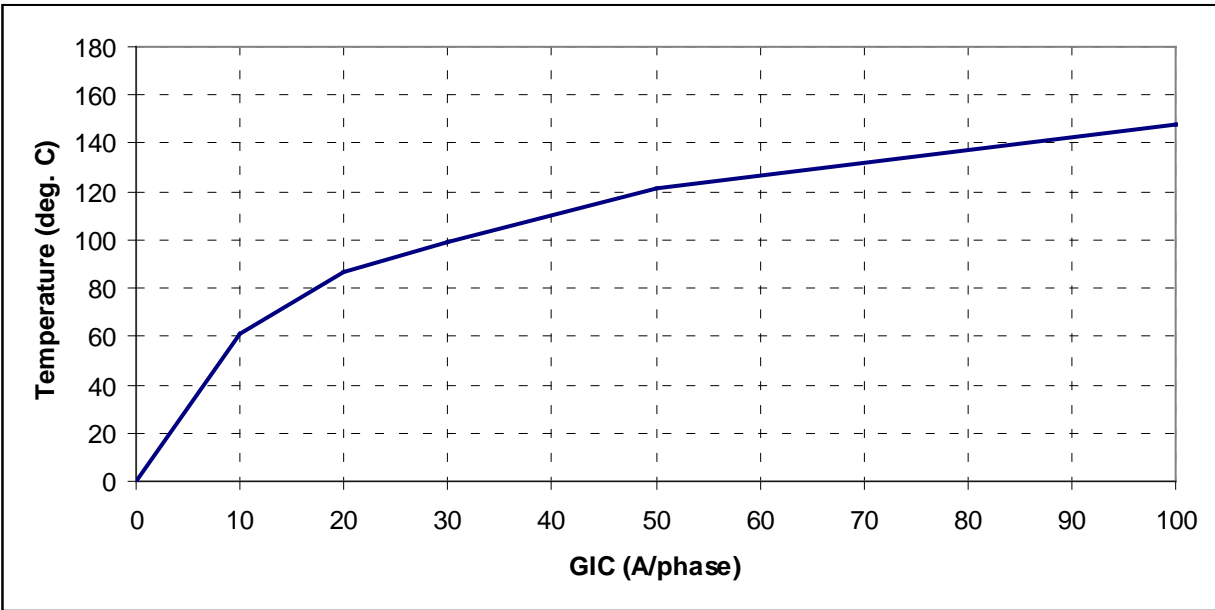


Figure 6I-4: Step thermal response of the tie plate of a 400 kV 400 MVA single-phase core-type autotransformer to a 10 A per phase dc step.





**Figure 71-5: Asymptotic thermal response of the tie plate of a 400 kV 400 MVA single-phase core-type autotransformer.**

The envelope in **Figure 1** can be used as a conservative thermal assessment for effective GIC values of **75 A per phase and greater associated with the benchmark waveform** (see **Table 21**).

Table 21: Upper Bound of Peak Metallic Hot Spot Temperatures Calculated Using the Benchmark GMD Event			
Effective GIC (A/phase)	Metallic hot spot Temperature (°C)	Effective GIC (A/phase)	Metallic hot spot Temperature (°C)
0	80	100	182
10	107	110	186
20	128	120	190
30	139	130	193
40	148	140	204
50	157	150	213
60	169	160	221
70	170	170	230
75	172	180	234
80	175	190	241
90	179	200	247

For instance, if effective GIC is 130 A per phase and oil temperature is assumed to be 80°C, peak hot spot temperature is 193°C. This value is below the 200°C IEEE Std C57.91-2011 threshold for short time emergency loading and this transformer will have passed the thermal assessment. If the full heat run oil temperature is 67°C at maximum ambient temperature, then 150 A per phase of effective GIC translates into a peak hot spot temperature of 200°C and the transformer will have passed. If the limit is lowered to 180°C to account for the condition of the transformer, then this would be an indication to “sharpen the pencil” and perform a detailed assessment. Some methods are described in Reference [1].

The temperature envelope in **Figure 1** corresponds to the values of effective GIC that result in the highest temperature for the benchmark GMD event. Different values of effective GIC could result in lower temperatures using the same model. For instance, the difference in upper and lower bounds of peak temperatures for the SVC coupling transformer model for 150 A per phase is approximately 30°C. In this case, GIC(t) should be generated to calculate the peak temperatures for the actual configuration of the transformer within the system as described in Reference [1]. Alternatively, a more precise thermal assessment could be carried out with a thermal model that more closely represents the thermal behavior of the transformer under consideration.

Similar to the discussion above, the envelope in **Figure 3** can be used as a conservative thermal assessment for effective GIC values of associated with the supplemental waveform (see **Table 2**). Because the supplemental waveform has a sharper peak, the peak metallic hot spot temperatures associated with the supplemental waveform are slightly lower than those associated with the benchmark waveform. Comparing **Tables 1 and 2** shows the magnitude of this difference.

<u>Effective GIC (A/phase)</u>	<u>Metallic hot spot Temperature (°C)</u>	<u>Effective GIC(A/phase)</u>	<u>Metallic hot spot Temperature (°C)</u>
<u>0</u>	<u>80</u>	<u>120</u>	<u>188</u>
<u>10</u>	<u>107</u>	<u>130</u>	<u>191</u>
<u>20</u>	<u>124</u>	<u>140</u>	<u>194</u>
<u>30</u>	<u>137</u>	<u>150</u>	<u>198</u>
<u>40</u>	<u>147</u>	<u>160</u>	<u>203</u>
<u>50</u>	<u>156</u>	<u>170</u>	<u>209</u>
<u>60</u>	<u>161</u>	<u>180</u>	<u>214</u>
<u>70</u>	<u>162</u>	<u>190</u>	<u>229</u>
<u>75</u>	<u>165</u>	<u>200</u>	<u>237</u>
<u>80</u>	<u>169</u>	<u>220</u>	<u>248</u>
<u>85</u>	<u>172</u>	<u>230</u>	<u>253</u>
<u>90</u>	<u>177</u>	<u>250</u>	<u>276</u>

<u>100</u>	<u>181</u>	<u>275</u>	<u>298</u>
<u>110</u>	<u>185</u>	<u>300</u>	<u>316</u>

## References

- [1] Transformer Thermal Impact Assessment white paper. Developed by the Project 2013-03 (Geomagnetic Disturbance) standard drafting team. Available at:  
<http://www.nerc.com/pa/Stand/Pages/Project-2013-03-Geomagnetic-Disturbance-Mitigation.aspx>  
<http://www.nerc.com/pa/stand/Pages/TPL0071RI.aspx>
- [2] Marti, L., Rezaei-Zare, A., Narang, A., "Simulation of Transformer Hotspot Heating due to Geomagnetically Induced Currents," *IEEE Transactions on Power Delivery*, vol.28, no.1, pp.320-327, Jan. 2013.
- [3] Lahtinen, Matti. Jarmo Elovaara. "GIC occurrences and GIC test for 400 kV system transformer". *IEEE Transactions on Power Delivery*, Vol. 17, No. 2. April 2002.
- [4] J. Raith, S. Ausserhofer: "GIC Strength verification of Power Transformers in a High Voltage Laboratory", GIC Workshop, Cape Town, April 2014
- [5] [5] "IEEE Guide for ~~loading mineral oil immersed transformers~~[Loading Mineral-Oil-Immersed Transformers](#) and ~~step voltage regulators~~[Step-Voltage Regulators](#)." IEEE Std C57.91-2011 (Revision of IEEE Std C57.91-1995).
- [6] "[IEEE Guide for Establishing Power Transformer Capability while under Geomagnetic Disturbances.](#)" [IEEE Std C57.163-2015.](#)

# Transformer Thermal Impact Assessment White Paper

## TPL-007-2—Transmission System Planned Performance for Geomagnetic Disturbance Events

### Background

Proposed TPL-007-2 includes requirements for entities to perform two types of GMD Vulnerability Assessments to evaluate the potential impacts of GMD events on the Bulk Electric System (BES):

- The benchmark GMD Vulnerability Assessment is based on the benchmark GMD event associated with TPL-007-1 which was approved by the Federal Energy Regulatory Commission (FERC) in Order No. 830 in September 2016. The benchmark GMD event is derived from spatially-averaged geoelectric field values to address potential wide-area effects that could be caused by a severe 1-in-100 year GMD event.<sup>1</sup>
- The supplemental GMD Vulnerability Assessment, based on the supplemental GMD event, is used by entities to evaluate localized peaks in geomagnetic field during a severe GMD event that "could potentially affect the reliable operation of the Bulk-Power System."<sup>2</sup> Localized enhancements of geomagnetic field can result in geoelectric field values above the spatially-averaged benchmark in a local area.

The standard requires transformer thermal impact assessments to be performed on BES power transformers with high side, wye-grounded windings with terminal voltage greater than 200 kV. Large power transformers connected to the EHV transmission system can experience both winding and structural hot spot heating as a result of GMD events. TPL-007-2 requires owners of such BES transformers to conduct thermal analyses to determine if the BES transformers will be able to withstand the thermal transient effects associated with the GMD events. BES Transformers must undergo a thermal impact assessment if the maximum effective geomagnetically-induced current (GIC) in the transformer is equal to or greater than:<sup>3</sup>

- 75 A per phase for the benchmark GMD event
- 85 A per phase for the supplemental GMD event

<sup>1</sup> See *Benchmark Geomagnetic Disturbance Event Description* white paper, May 12, 2016. Filed by NERC in RM15-11 on June 28, 2016.

<sup>2</sup> See Order No. 830 P. 47. On September 22, 2016, FERC directed NERC to develop modifications to the benchmark GMD event, included in TPL-007-1, such that assessments would not be based solely on spatially averaged data. The characteristics of a GMD event for this assessment are in the Supplemental GMD Event Description white paper.

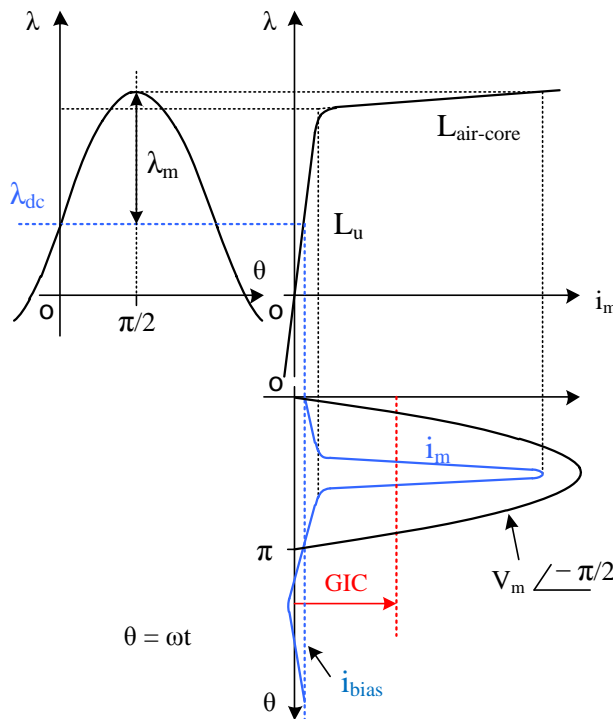
<sup>3</sup> See *Screening Criterion for Transformer Thermal Impact Assessment* for technical justification.

This white paper discusses methods that can be employed to conduct transformer thermal impact assessments, including example calculations. The first version of the white paper was developed by the Project 2013-03 GMD Standards Drafting Team (SDT) for TPL-007-1 and was endorsed by the Electric Reliability Organization (ERO) as implementation guidance in October 2016. The SDT has updated the white paper to include the supplemental GMD event that is added in TPL-007-2 to address directives in FERC Order No. 830.

The primary impact of GMDs on large power transformers is a result of the quasi-dc current that flows through wye-grounded transformer windings. This geomagnetically-induced current (GIC) results in an offset of the ac sinusoidal flux resulting in asymmetric or half-cycle saturation (see **Figure 1**).

Half-cycle saturation results in a number of known effects:

- Hot spot heating of transformer windings due to harmonics and stray flux;
- Hot spot heating of non-current carrying transformer metallic members due to stray flux;
- Harmonics;
- Increase in reactive power absorption; and
- Increase in vibration and noise level.



**Figure 1: Mapping Magnetization Current to Flux through Core Excitation Characteristics**

This paper focuses on hot spot heating of transformer windings and non current-carrying metallic parts. Effects such as the generation of harmonics, increase in reactive power absorption, vibration, and noise are not within the scope of this document.

## Technical Considerations

The effects of half-cycle saturation on HV and EHV transformers, namely localized “hot spot” heating, are relatively well understood, but are difficult to quantify. A transformer GMD impact assessment must consider GIC amplitude, duration, and transformer physical characteristics such as design and condition (e.g., age, gas content, and moisture in the oil). A single threshold value of GIC cannot be justified as a “pass or fail” screening criterion where “fail” means that the transformer will suffer damage. A single threshold value of GIC only makes sense in the context where “fail” means that a more detailed study is required. Such a threshold would have to be technically justifiable and sufficiently low to be considered a conservative value of GIC.

The following considerations should be taken into account when assessing the thermal susceptibility of a transformer to half-cycle saturation:

- In the absence of manufacturer specific information, use the temperature limits for safe transformer operation such as those suggested in the IEEE Std C57.91-2011 (IEEE Guide for Loading Mineral-oil-immersed Transformers and Step-voltage Regulators) for hot spot heating during short-term emergency operation [1]. This standard does not suggest that exceeding these limits will result in transformer failure, but rather that it will result in additional aging of cellulose in the paper-oil insulation and the potential for the generation of gas bubbles in the bulk oil. Thus, from the point of view of evaluating possible transformer damage due to increased hot spot heating, these thresholds can be considered conservative for a transformer in good operational condition.
- The worst case temperature rise for winding and metallic part (e.g., tie plate) heating should be estimated taking into consideration the construction characteristics of the transformer as they pertain to dc flux offset in the core (e.g., single-phase, shell, 5 and 3-leg three-phase construction).
- Bulk oil temperature due to ambient temperature and transformer loading must be added to the incremental temperature rise caused by hot spot heating. For planning purposes, maximum ambient and loading temperature should be used unless there is a technically justified reason to do otherwise.
- The time series or “waveform” of the reference GMD event in terms of peak amplitude, duration, and frequency of the geoelectric field has an important effect on hot spot heating. Winding and metallic part hot spot heating have different thermal time constants, and their temperature rise will be different if the GIC currents are sustained for 2, 10, or 30 minutes for a given GIC peak amplitude.
- The “effective” GIC in autotransformers (reflecting the different GIC ampere-turns in the common and the series windings) must be used in the assessment. The effective current  $I_{dc,eq}$  in an autotransformer is defined by [2].

$$I_{dc,eq} = I_H + (I_N / 3 - I_H) V_X / V_H \quad (1)$$

where

$I_H$  is the dc current in the high voltage winding;

$I_N$  is the neutral dc current;

$V_H$  is the rms rated voltage at HV terminals;

$V_X$  is the rms rated voltage at the LV terminals.

## Transformer Thermal Impact Assessment Process

A simplified thermal assessment may be based on the appropriate tables from the “Screening Criterion for Transformer Thermal Impact Assessment” white paper [3].<sup>4</sup> Each table below provides the peak metallic hot spot temperatures that can be reached for the given GMD event using conservative thermal models. To use each table, one must select the bulk oil temperature and the threshold for metallic hot spot heating, for instance, from reference [1] after allowing for possible de-rating due to transformer condition. If the effective GIC results in higher than threshold temperatures, then the use of a detailed thermal assessment as described below should be carried out.<sup>5</sup>

Table 1: Upper Bound of Peak Metallic Hot Spot Temperatures Calculated Using the Benchmark GMD Event			
Effective GIC (A/phase)	Metallic hot spot Temperature (°C)	Effective GIC (A/phase)	Metallic hot spot Temperature (°C)
0	80	100	182
10	107	110	186
20	128	120	190
30	139	130	193
40	148	140	204
50	157	150	213
60	169	160	221
70	170	170	230
75	172	180	234
80	175	190	241
90	179	200	247

<sup>4</sup> Table 1 in the *Screening Criterion for Transformer Thermal Impact Assessment* white paper provides upper bound temperatures for the benchmark GMD event. Table 2 in the *Screening Criterion for Transformer Thermal Impact Assessment* white paper provides upper bound temperatures for the supplemental GMD event.

<sup>5</sup> Effective GIC in the table is the peak GIC(t) for the GMD event being assessed. Peak GIC(t) is not steady-state GIC.



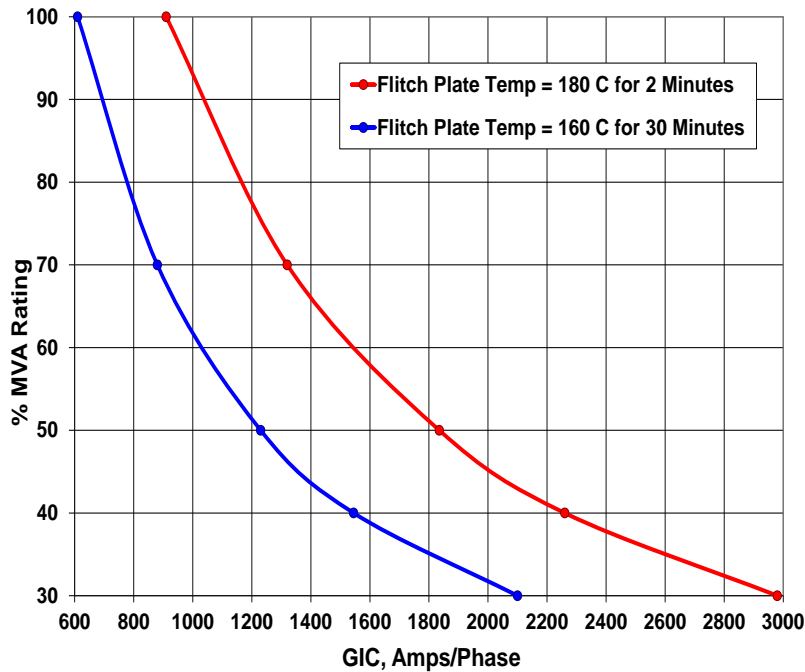
**Table 2: Upper Bound of Peak Metallic Hot Spot Temperatures Calculated Using the Supplemental GMD Event**

Effective GIC (A/phase)	Metallic hot spot Temperature (°C )	Effective GIC(A/phase)	Metallic hot spot Temperature (°C )
0	80	120	188
10	107	130	191
20	124	140	194
30	137	150	198
40	147	160	203
50	156	170	209
60	161	180	214
70	162	190	229
75	165	200	237
80	169	220	248
85	172	230	253
90	177	250	276
100	181	275	298
110	185	300	316

Two different ways to carry out a detailed thermal impact assessment are discussed below. In addition, other approaches and models approved by international standard-setting organizations such as the Institute of Electrical and Electronic Engineers (IEEE) or International Council on Large Electric Systems (CIGRE) may also provide technically justified methods for performing thermal assessments.<sup>6</sup> All thermal assessment methods should be demonstrably equivalent to assessments that use the GMD events associated with TPL-007-2.

1. Transformer manufacturer GIC capability curves. These curves relate permissible peak GIC (obtained by the user from a steady-state GIC calculation) and loading, for a specific transformer. An example of manufacturer capability curves is provided in **Figure 2**. Presentation details vary between manufacturers, and limited information is available regarding the assumptions used to generate these curves, in particular, the assumed waveshape or duration of the effective GIC. Some manufacturers assume that the waveform of the GIC in the transformer windings is a square pulse of 2, 10, or 30 minutes in duration. In the case of the transformer capability curve shown in **Figure 2**, a square pulse of 900 A/phase with a duration of 2 minutes would cause the Flitch plate hot spot to reach a temperature of 180°C at full load [5]. While GIC capability curves are relatively simple to use, an amount of engineering judgment is necessary to ascertain which portion of a GIC waveform is equivalent to, for example, a 2 minute pulse. Also, manufacturers generally maintain that in the absence of transformer standards defining thermal duty due to GIC, such capability curves must be developed for every transformer design and vintage.

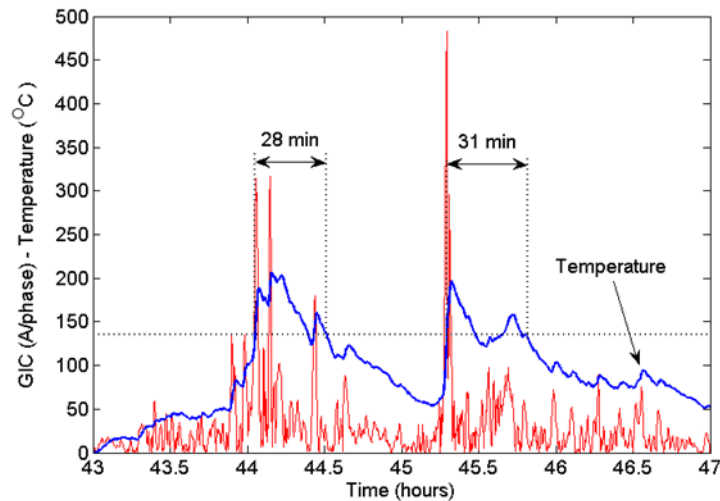
<sup>6</sup> For example, C57.163-2015 – IEEE Guide for Establishing Power Transformer Capability while under Geomagnetic Disturbances. [4]



**Figure 2: Sample GIC Manufacturer Capability Curve of a Large Single-Phase Transformer Design using the Flitch Plate Temperature Criteria [5]**

2. Thermal response simulation.<sup>7</sup> The input to this type of simulation is the time series or waveform of effective GIC flowing through a transformer (taking into account the actual configuration of the system), and the result of the simulation is the hot spot temperature (winding or metallic part) time sequence for a given transformer. An example of GIC input and hotspot temperature time series values from [6] are shown in **Figure 3**. The hot spot thermal transfer functions can be obtained from measurements or calculations provided by transformer manufacturers. Conservative default values can be used (e.g., those provided in [6]) when specific data are not available. Hot spot temperature thresholds shown in **Figure 3** are consistent with IEEE Std C57.91-2011 emergency loading hot spot limits. Emergency loading time limit is usually 30 minutes.

<sup>7</sup> Technical details of this methodology can be found in [6].



**Figure 3: Sample Tie Plate Temperature Calculation**

Blue trace is incremental temperature and red trace is the magnitude of the GIC/phase [6]

It is important to reiterate that the characteristics of the time sequence or “waveform” are very important in the assessment of the thermal impact of GIC on transformers. Transformer hot spot heating is not instantaneous. The thermal time constants of transformer windings and metallic parts are typically on the order of minutes to tens of minutes; therefore, hot spot temperatures are heavily dependent on GIC history and rise time, amplitude and duration of GIC in the transformer windings, bulk oil temperature due to loading, ambient temperature and cooling mode.

### Calculation of the GIC Waveform for a Transformer

The following procedure can be used to generate time series GIC data (i.e.,  $GIC(t)$ ) using a software program capable of computing GIC in the steady-state. The steps are as follows:

1. Calculate contribution of GIC due to eastward and northward geoelectric fields for the transformer under consideration;
2. Scale the GIC contribution according to the reference geoelectric field time series to produce the GIC time series for the transformer under consideration.

Most available GIC-capable software packages can calculate GIC in steady-state in a transformer assuming a uniform eastward geoelectric field of 1 V/km ( $GIC_E$ ) while the northward geoelectric field is zero. Similarly,  $GIC_N$  can be obtained for a uniform northward geoelectric field of 1 V/km while the eastward geoelectric field is zero.  $GIC_E$  and  $GIC_N$  are the normalized GIC contributions for the transformer under consideration.

If the earth conductivity is assumed to be uniform (or laterally uniform) in the transmission system of interest, then the transformer GIC (in A/phase) for any value of  $E_E(t)$  and  $E_N(t)$  can be calculated using (2) [2].

$$GIC(t) = |E(t)| \cdot \{GIC_E \sin(\varphi(t)) + GIC_N \cos(\varphi(t))\} \quad (2)$$

where

$$|E(t)| = \sqrt{E_N^2(t) + E_E^2(t)} \quad (3)$$

$$\varphi(t) = \tan^{-1} \left( \frac{E_E(t)}{E_N(t)} \right) \quad (4)$$

$$GIC(t) = E_E(t) \cdot GIC_E + E_N(t) \cdot GIC_N \quad (5)$$

$GIC_N$  is the effective GIC due to a northward geoelectric field of 1 V/km, and  $GIC_E$  is the effective GIC due to an eastward geoelectric field of 1 V/km. The units for  $GIC_N$  and  $GIC_E$  are A/phase per V/km)

The geoelectric field time series  $E_N(t)$  and  $E_E(t)$  is obtained, for instance, from the reference geomagnetic field time series (from [7] and/or [8]) after the appropriate geomagnetic latitude scaling factor  $\alpha$  is applied.<sup>8</sup> The reference geoelectric field time series is calculated using the reference earth model. When using this geoelectric field time series where a different earth model is applicable, it should be scaled with the appropriate conductivity scaling factor  $\beta$ .<sup>9</sup> Alternatively, the geoelectric field can be calculated from the reference geomagnetic field time series after the appropriate geomagnetic latitude scaling factor  $\alpha$  is applied and the appropriate earth model is used. In such case, the conductivity scaling factor  $\beta$  is not applied because it is already accounted for by the use of the appropriate earth model.

Applying (5) to each point in  $E_N(t)$  and  $E_E(t)$  results in  $GIC(t)$ .

### GIC(t) Calculation Example

Let us assume that from the steady-state solution, the effective GIC in this transformer is  $GIC_E = -20$  A/phase if  $E_N=0$ ,  $E_E=1$  V/km and  $GIC_N = 26$  A/phase if  $E_N=1$  V/km,  $E_E=0$ . Let us also assume the geomagnetic field time series corresponds to a geomagnetic latitude where  $\alpha = 1$  and that the earth conductivity corresponds to the reference earth model in [7]. The resulting geoelectric field time series is shown in **Figure 4**. Therefore:

$$GIC(t) = E_E(t) \cdot GIC_E + E_N(t) \cdot GIC_N \text{ (A/phase)} \quad (6)$$

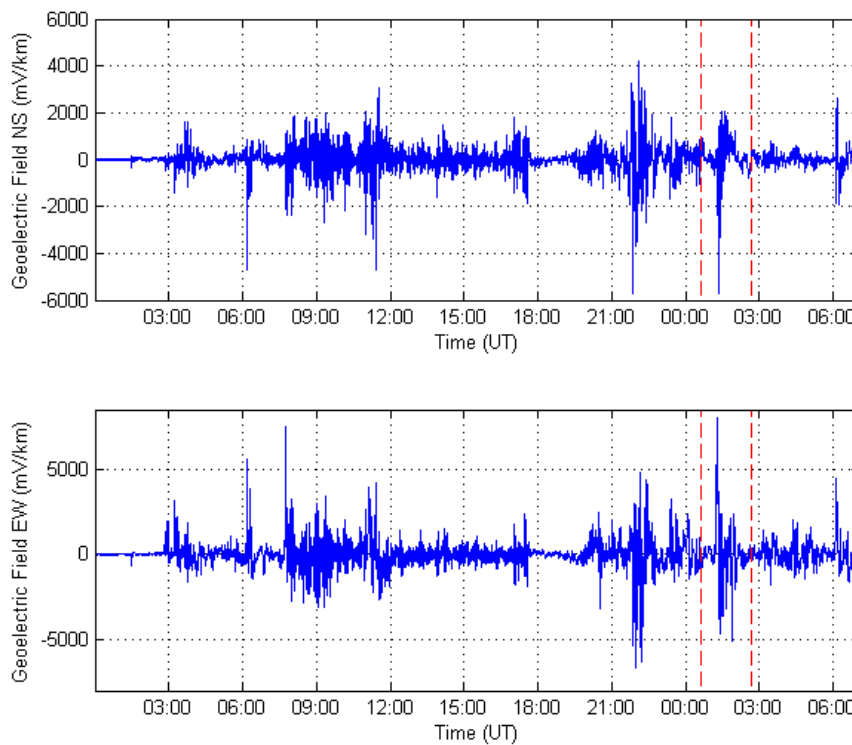
$$GIC(t) = -E_E(t) \cdot 20 + E_N(t) \cdot 26 \text{ (A/phase)} \quad (7)$$

<sup>8</sup> The geomagnetic factor  $\alpha$  is described in [2] and is used to scale the geomagnetic field according to geomagnetic latitude. The lower the geomagnetic latitude (closer to the equator), the lower the amplitude of the geomagnetic field.

<sup>9</sup> The conductivity scaling factor  $\beta$  is described in [2], and is used to scale the geoelectric field according to the conductivity of different physiographic regions. Lower conductivity results in higher  $\beta$  scaling factors.

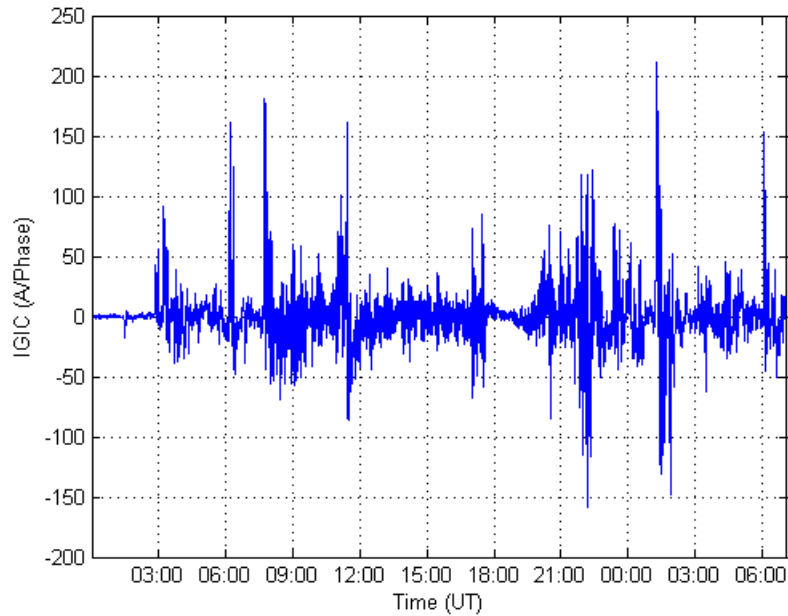
The resulting GIC waveform  $GIC(t)$  is shown in **Figures 5 and 6** and can subsequently be used for thermal analysis.

It should be emphasized that even for the same reference event, the  $GIC(t)$  waveform in every transformer will be different, depending on the location within the system and the number and orientation of the circuits connecting to the transformer station. Assuming a single generic  $GIC(t)$  waveform to test all transformers is incorrect.

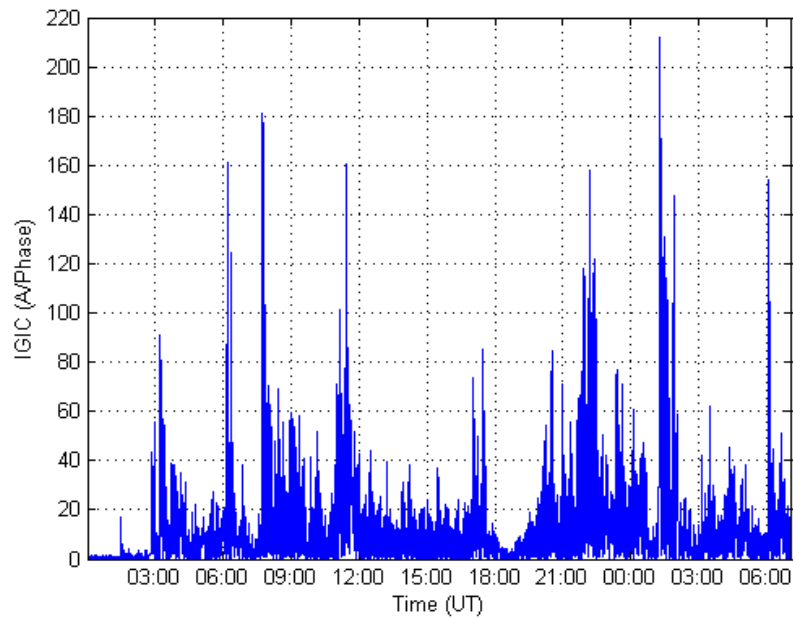


**Figure 4: Calculated Geoelectric Field  $E_N(t)$  and  $E_E(t)$  Assuming  $\alpha=1$  and  $\beta=1$  (Reference Earth Model).**

Zoom area for subsequent graphs is highlighted.  
 Dashed lines approximately show the close-up area for subsequent Figures.



**Figure 5: Calculated GIC(t) Assuming  $\alpha=1$  and  $\beta=1$  Reference Earth Model**



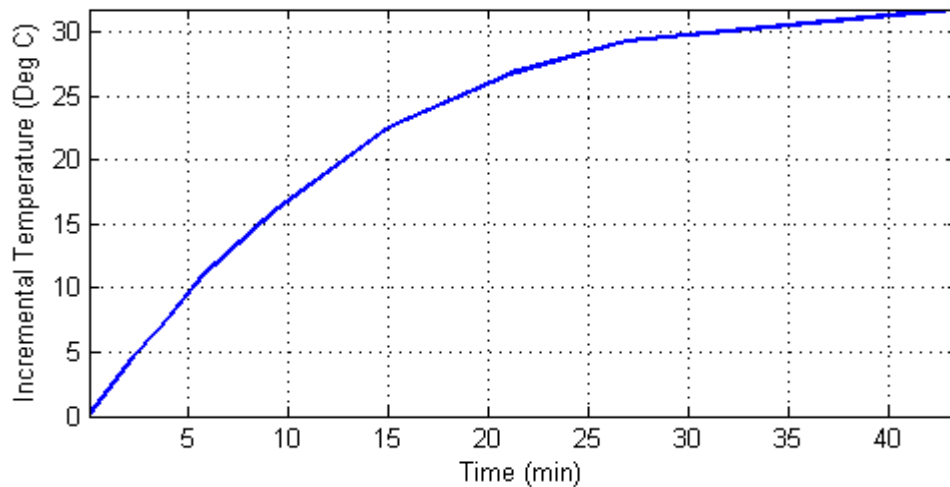
**Figure 6: Calculated Magnitude of GIC(t) Assuming  $\alpha=1$  and  $\beta=1$  Reference Earth Model**

### Transformer Thermal Assessment Examples

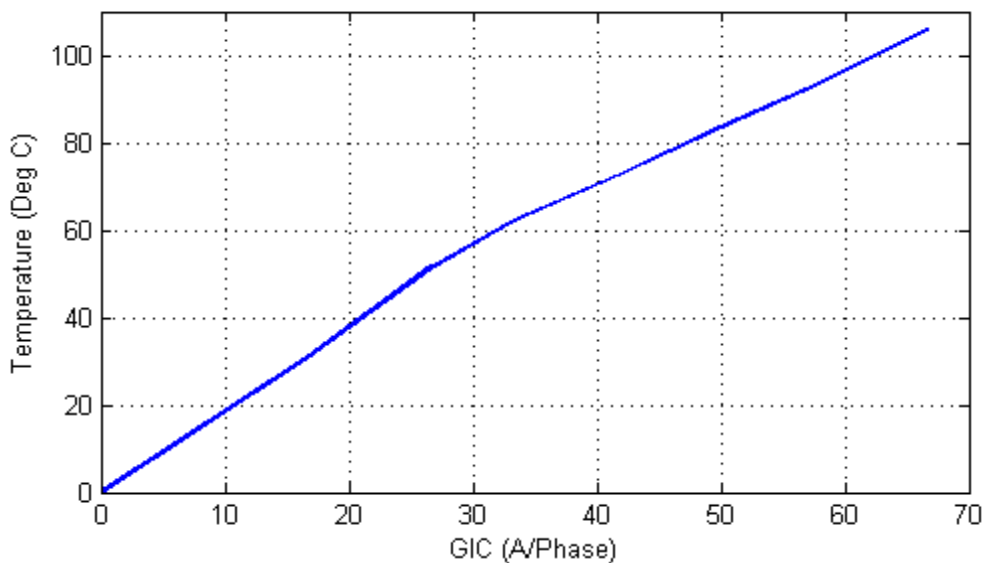
There are two basic ways to carry out a transformer thermal analysis once the GIC time series GIC(t) is known for a given transformer: 1) calculating the thermal response as a function of time; and 2) using manufacturer’s capability curves.

**Example 1: Calculating thermal response as a function of time using a thermal response tool**

The thermal step response of the transformer can be obtained for both winding and metallic part hot spots from: 1) measurements; 2) manufacturer’s calculations; or 3) generic published values. **Figure 7** shows the measured metallic hot spot thermal response to a dc step of 16.67 A/phase of the top yoke clamp from [9] that will be used in this example. **Figure 8** shows the measured incremental temperature rise (asymptotic response) of the same hot spot to long duration GIC steps.<sup>10</sup>



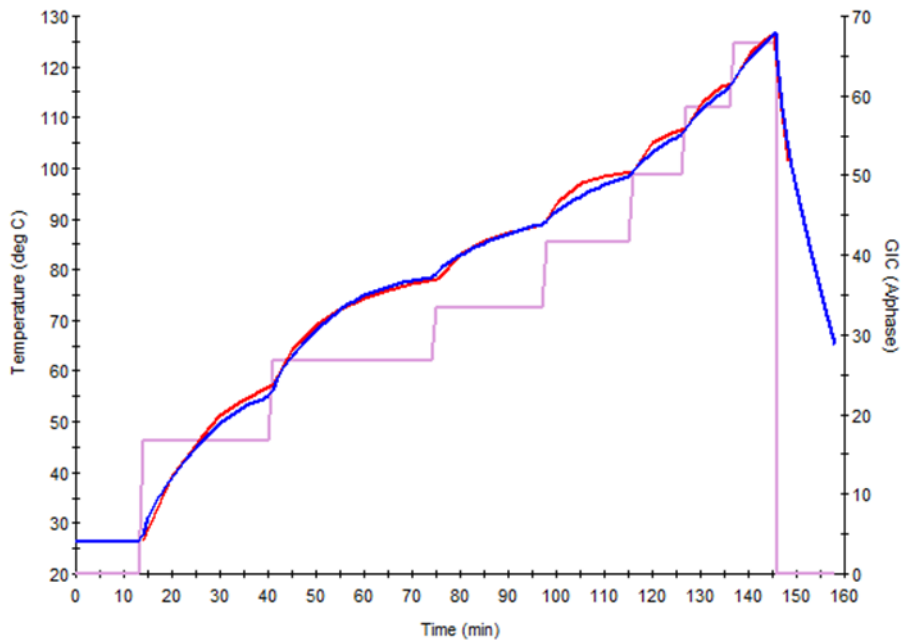
**Figure 7: Thermal Step Response to a 16.67 Amperes per Phase dc Step**  
Metallic hot spot heating



**Figure 8: Asymptotic Thermal Step Response**  
Metallic hot spot heating

<sup>10</sup> Heating of bulk oil due to the hot spot temperature increase is not included in the asymptotic response because the time constant of bulk oil heating is at least an order of magnitude larger than the time constants of hot spot heating.

The step response in **Figure 7** was obtained from the first GIC step of the tests carried out in [6]. The asymptotic thermal response in **Figure 8** was obtained from the final or near-final temperature values after each subsequent GIC step. **Figure 9** shows a comparison between measured temperatures and the calculated temperatures using the thermal response model used in the rest of this discussion.

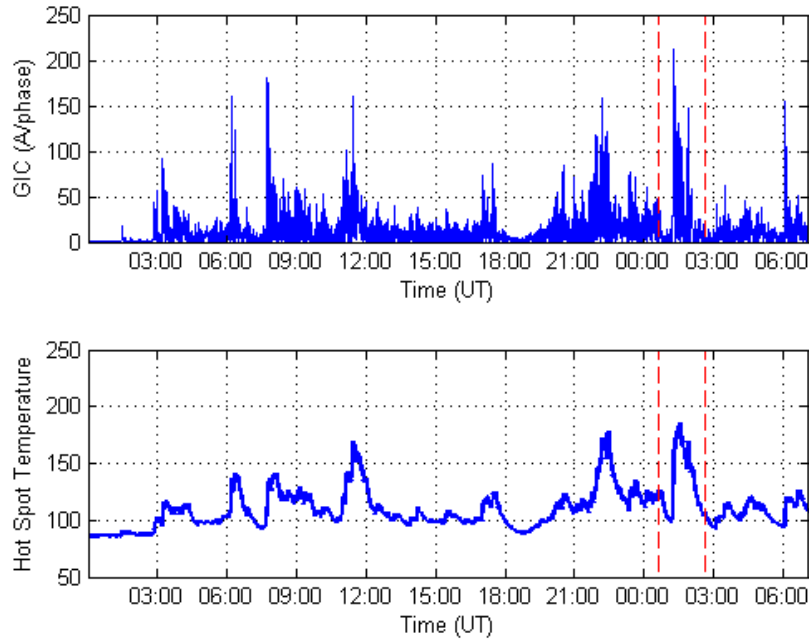


**Figure 9: Comparison of measured temperatures (red) and simulation results (blue).**  
 Injected current is represented by magenta.

To obtain the thermal response of the transformer to a GIC waveform such as the one in **Figure 6**, a thermal response model is required. To create a thermal response model, the measured or manufacturer-calculated transformer thermal step responses (winding and metallic part) for various GIC levels are required. The GIC(t) time series or waveform is then applied to the thermal model to obtain the incremental temperature rise as a function of time  $\theta(t)$  for the GIC(t) waveform. The total temperature is calculated by adding the oil temperature, for example, at full load.

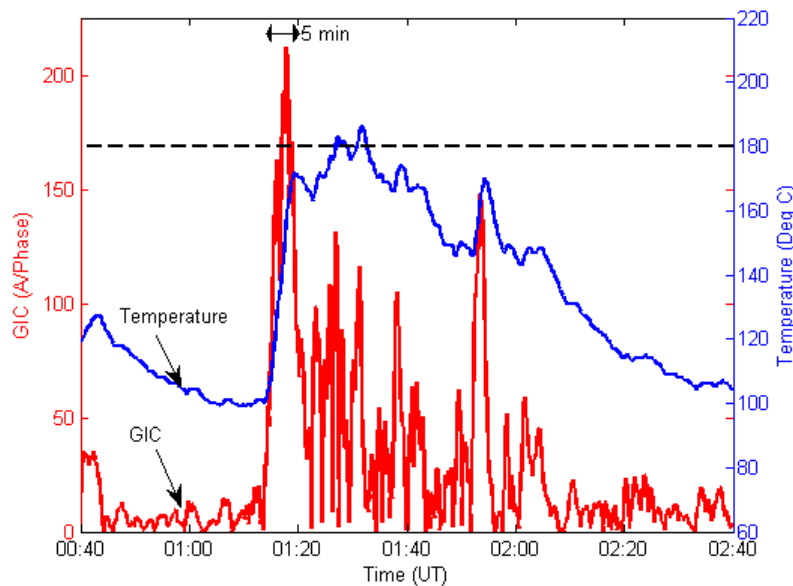


**Figure 10** illustrates the calculated GIC(t) and the corresponding metallic hot spot temperature time series  $\theta(t)$ . **Figure 11** illustrates a close-up view of the peak transformer temperatures calculated in this example.



**Figure 10: Magnitude of GIC(t) and Metallic Hot Spot Temperature  $\theta(t)$  Assuming Full Load Oil Temperature of 85.3°C (40°C ambient).**

Dashed lines approximately show the close-up area for subsequent figures



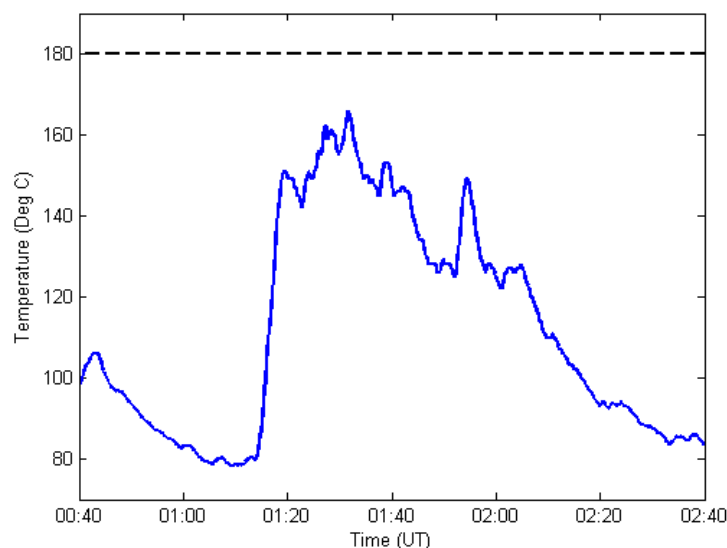
**Figure 11: Close-up of Metallic Hot Spot Temperature Assuming a Full Load**  
Blue trace is  $\theta(t)$ . Red trace is GIC(t)

In this example, the IEEE Std C57.91-2011 emergency loading hot spot threshold of 200°C for metallic hot spot heating is not exceeded. Peak temperature is 186°C. The IEEE standard is silent as to whether the temperature can be higher than 200°C for less than 30 minutes. Manufacturers can provide guidance on individual transformer capability.

It is not unusual to use a lower temperature threshold of 180°C to account for calculation and data margins, as well as transformer age and condition. **Figure 11** shows that 180°C will be exceeded for 5 minutes.

At 75% loading, the initial temperature is 64.6°C rather than 85.3°C, and the hot spot temperature peak is 165°C, well below the 180°C threshold (see **Figure 12**).

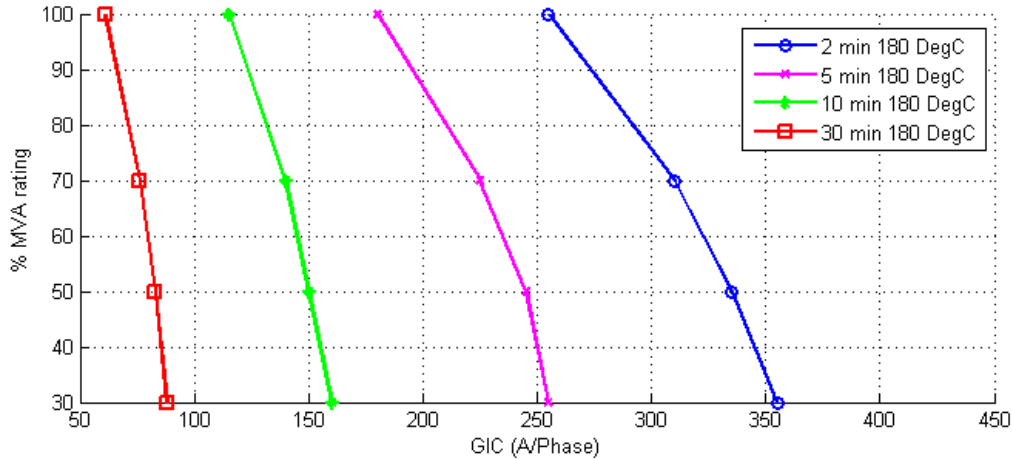
If a conservative threshold of 160°C were used to account for the age and condition of the transformer, then the full load limits would be exceeded for approximately 22 minutes.



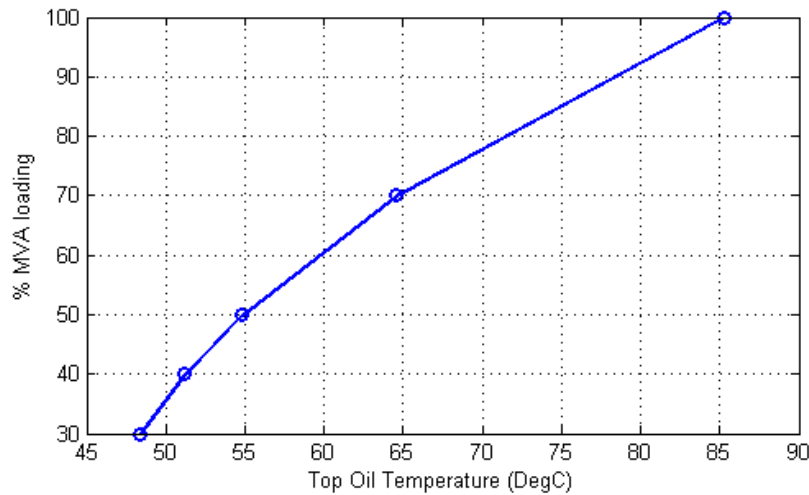
**Figure 12: Close-up of Metallic Hot Spot Temperature Assuming a 75% Load**  
Oil temperature of 64.5°C

**Example 2: Using a Manufacturer's Capability Curves**

The capability curves used in this example are shown in **Figure 13**. To maintain consistency with the previous example, these particular capability curves have been reconstructed from the thermal step response shown in **Figures 7 and 8**, and the simplified loading curve shown in **Figure 14** (calculated using formulas from IEEE Std C57.91-2011).



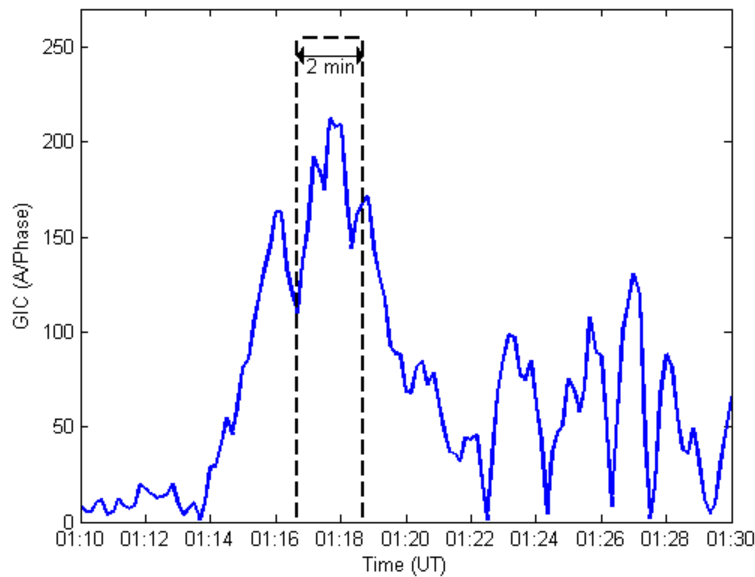
**Figure 13: Capability Curve of a Transformer Based on the Thermal Response Shown in Figures 8 and 9.**



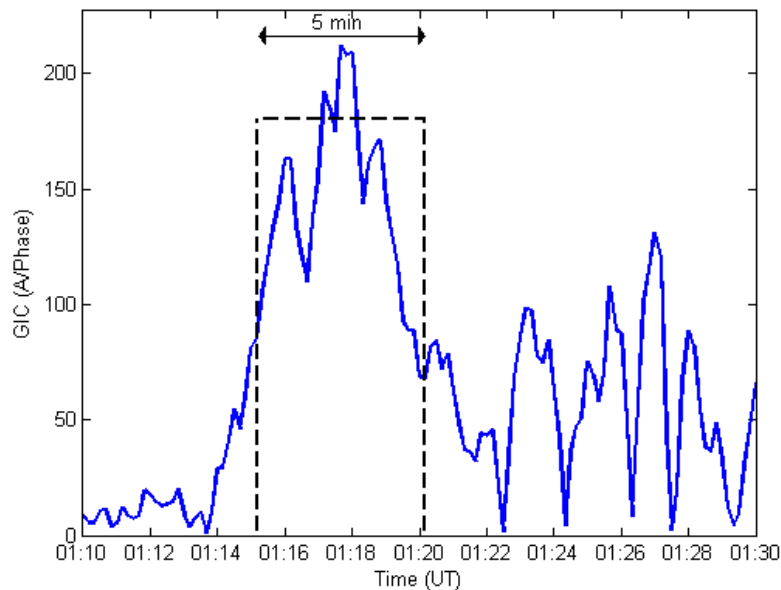
**Figure 14: Simplified Loading Curve Assuming 40°C Ambient Temperature.**

The basic notion behind the use of capability curves is to compare the calculated GIC in a transformer with the limits at different GIC pulse widths. A narrow GIC pulse has a higher limit than a longer duration or wider one. If the calculated GIC and assumed pulse width falls below the appropriate pulse width curve, then the transformer is within its capability.

To use these curves, it is necessary to estimate an equivalent square pulse that matches the waveform of GIC(t), generally at a GIC(t) peak. **Figure 15** shows a close-up of the GIC near its highest peak superimposed to a 255 Amperes per phase, 2 minute pulse at 100% loading from **Figure 13**. Since a narrow 2-minute pulse is not representative of GIC(t) in this case, a 5 minute pulse with an amplitude of 180 A/phase at 100% loading has been superimposed on **Figure 16**. It should be noted that a 255 A/phase, 2 minute pulse is equivalent to a 180 A/phase 5 minute pulse from the point of view of transformer capability. Deciding what GIC pulse is equivalent to the portion of GIC(t) under consideration is a matter of engineering judgment.



**Figure 15: Close-up of GIC(t) and a 2 minute 255 A/phase GIC pulse at full load**

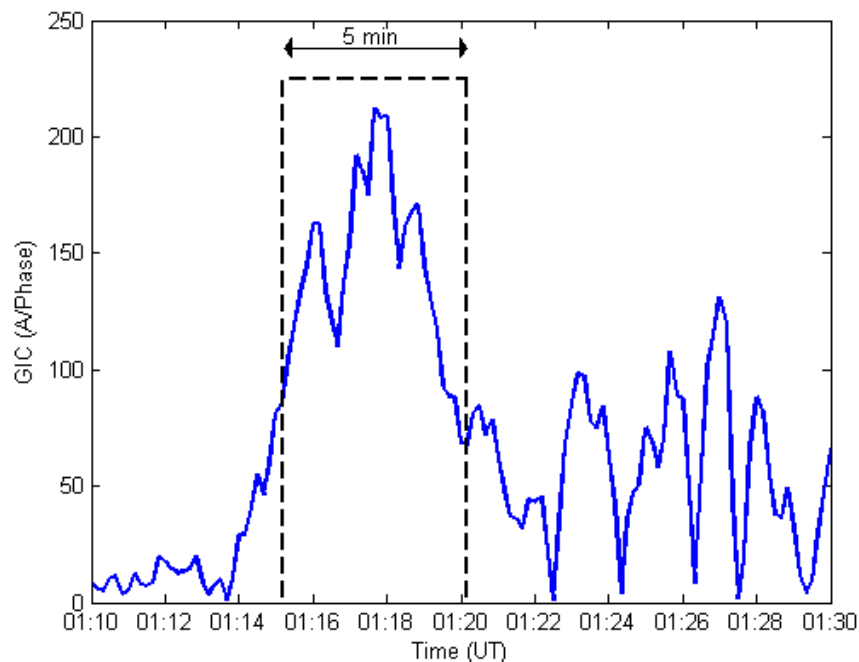


**Figure 16: Close-up of GIC(t) and a Five Minute 180 A/phase GIC Pulse at Full Load**

When using a capability curve, it should be understood that the curve is derived assuming that there is no hot spot heating due to prior GIC at the time the GIC pulse occurs (only an initial temperature due to loading). Therefore, in addition to estimating the equivalent pulse that matches GIC(t), prior metallic hot spot heating must be accounted for. From these considerations, it is unclear whether the capability curves would be exceeded at full load with a 180°C threshold in this example.

At 70% loading, the two and five minute pulses from **Figure 13** would have amplitudes of 310 and 225 A/phase, respectively. The 5 minute pulse is illustrated in **Figure 17**. In this case, judgment is also required to assess if the GIC(t) is within the capability curve for 70% loading. In general, capability curves are easier to use when GIC(t) is substantially above, or clearly below the GIC thresholds for a given pulse duration.

If a conservative threshold of 160°C were used to account for the age and condition of the transformer, then a new set of capability curves would be required.



**Figure 17: Close-up of GIC(t) and a 5 Minute 225 A/phase GIC Pulse Assuming 75% Load**

## References

- [1] "IEEE Guide for loading mineral-oil-immersed transformers and step-voltage regulators." IEEE Std C57.91-2011 (Revision of IEEE Std C57.91-1995).
- [2] Application Guide: Computing Geomagnetically-Induced Current in the Bulk-Power System, NERC. Available at:  
[http://www.nerc.com/comm/PC/Geomagnetic%20Disturbance%20Task%20Force%20GMDTF%202013/GIC%20Application%20Guide%202013\\_approved.pdf](http://www.nerc.com/comm/PC/Geomagnetic%20Disturbance%20Task%20Force%20GMDTF%202013/GIC%20Application%20Guide%202013_approved.pdf)
- [3] "Screening Criterion for Transformer Thermal Impact Assessment". Developed by the Project 2013-03 (Geomagnetic Disturbance) standard drafting team. Available at:  
<http://www.nerc.com/pa/stand/Pages/TPL0071RI.aspx>
- [4] "IEEE Guide for Establishing Power Transformer Capability while under Geomagnetic Disturbances." IEEE Std C57.163-2015
- [5] Girgis, R.; Vedante, K. "Methodology for evaluating the impact of GIC and GIC capability of power transformer designs." IEEE PES 2013 General Meeting Proceedings. Vancouver, Canada.
- [6] Marti, L., Rezaei-Zare, A., Narang, A. "Simulation of Transformer Hotspot Heating due to Geomagnetically Induced Currents." IEEE Transactions on Power Delivery, vol.28, no.1. pp 320-327. January 2013.
- [7] Benchmark Geomagnetic Disturbance Event Description white paper. Developed by the Project 2013-03 (Geomagnetic Disturbance) standard drafting team. Available at:  
<http://www.nerc.com/pa/stand/Pages/TPL0071RI.aspx>
- [8] Supplemental Geomagnetic Disturbance Event Description white paper. Developed by the Project 2013-03 (Geomagnetic Disturbance) standard drafting team. Available at:  
<http://www.nerc.com/pa/Stand/Pages/Project-2013-03-Geomagnetic-Disturbance-Mitigation.aspx>
- [9] Lahtinen, Matti. Jarmo Elovaara. "GIC occurrences and GIC test for 400 kV system transformer". IEEE Transactions on Power Delivery, Vol. 17, No. 2. April 2002.

# Transformer Thermal Impact Assessment White Paper

~~Project 2013-03 (Geomagnetic Disturbance Mitigation)~~

~~TPL-007-+2-Transmission System Planned Performance for Geomagnetic Disturbance Events~~

## Background

~~On May 16, 2013, FERC issued Order No. 779, directing NERC to develop Standards that address risks to reliability caused by geomagnetic disturbances (GMDs) in two stages:~~

- ~~• Stage 1 Standard(s) that require applicable entities to develop and implement Operating Procedures. EOP-010-1-Geomagnetic Disturbance Operations was approved by FERC in June 2014.~~
- ~~• Stage 2 Standard(s) that require applicable entities to conduct assessments of the potential impact of benchmark GMD events on their systems. If the assessments identify potential impacts, the Standard(s) will require the applicable entity to develop and implement a plan to mitigate the risk.~~

~~TPL-007-1 is a new Reliability Standard to specifically address the Stage 2 directives in Order No. 779.~~

~~Large power transformers connected to the EHV transmission system can experience both winding and structural hot spot heating as a result of GMD events. TPL-007-1 will require owners of such transformers to conduct thermal analyses of their transformers to determine if the transformers will be able to withstand the thermal transient effects associated with the Benchmark GMD event. This paper discusses methods that can be employed to conduct such analyses, including example calculations.~~

~~Proposed TPL-007-2 includes requirements for entities to perform two types of GMD Vulnerability Assessments to evaluate the potential impacts of GMD events on the Bulk Electric System (BES):~~

- ~~• The benchmark GMD Vulnerability Assessment is based on the benchmark GMD event associated with TPL-007-1 which was approved by the Federal Energy Regulatory Commission (FERC) in Order No. 830 in September 2016. The benchmark GMD event is derived from spatially-averaged geoelectric field values to address potential wide-area effects that could be caused by a severe 1-in-100 year GMD event.<sup>1</sup>~~
- ~~• The supplemental GMD Vulnerability Assessment, based on the supplemental GMD event, is used by entities to evaluate localized peaks in geomagnetic field during a severe GMD event that "could~~

<sup>1</sup> ~~See Benchmark Geomagnetic Disturbance Event Description white paper, May 12, 2016. Filed by NERC in RM15-11 on June 28, 2016.~~

potentially affect the reliable operation of the Bulk-Power System."<sup>2</sup> Localized enhancements of geomagnetic field can result in geoelectric field values above the spatially-averaged benchmark in a local area.

The standard requires transformer thermal impact assessments to be performed on BES power transformers with high side, wye-grounded windings with terminal voltage greater than 200 kV. Large power transformers connected to the EHV transmission system can experience both winding and structural hot spot heating as a result of GMD events. TPL-007-2 requires owners of such BES transformers to conduct thermal analyses to determine if the BES transformers will be able to withstand the thermal transient effects associated with the GMD events. BES Transformers must undergo a thermal impact assessment if the maximum effective geomagnetically-induced current (GIC) in the transformer is equal to or greater than:<sup>3</sup>

- 75 A per phase for the benchmark GMD event
- 85 A per phase for the supplemental GMD event

This white paper discusses methods that can be employed to conduct transformer thermal impact assessments, including example calculations. The first version of the white paper was developed by the Project 2013-03 GMD Standards Drafting Team (SDT) for TPL-007-1 and was endorsed by the Electric Reliability Organization (ERO) as implementation guidance in October 2016. The SDT has updated the white paper to include the supplemental GMD event that is added in TPL-007-2 to address directives in FERC Order No. 830.

The primary impact of GMDs on large power transformers is a result of the quasi-dc current that flows through wye-grounded transformer windings. This geomagnetically-induced current (GIC) results in an offset of the ac sinusoidal flux resulting in asymmetric or half-cycle saturation (see **Figure 1**).

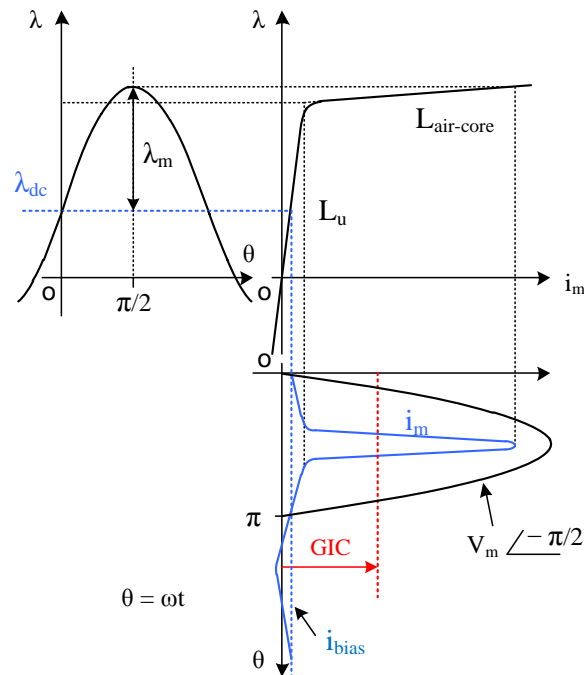
Half-cycle saturation results in a number of known effects:

- Hot spot heating of transformer windings due to harmonics and stray flux;
- Hot spot heating of non-current carrying transformer metallic members due to stray flux;
- Harmonics;
- Increase in reactive power absorption; and
- Increase in vibration and noise level.

<sup>2</sup> See Order No. 830 P. 47. On September 22, 2016, FERC directed NERC to develop modifications to the benchmark GMD event, included in TPL-007-1, such that assessments would not be based solely on spatially averaged data. The characteristics of a GMD event for this assessment are in the Supplemental GMD Event Description white paper.

<sup>3</sup> See *Screening Criterion for Transformer Thermal Impact Assessment* for technical justification.





**Figure 1: Mapping Magnetization Current to Flux through Core Excitation Characteristics**

This paper focuses on hot spot heating of transformer windings and non current-carrying metallic parts. Effects such as the generation of harmonics, increase in reactive power absorption, vibration, and noise are not within the scope of this document.

## Technical Considerations

The effects of half-cycle saturation on HV and EHV transformers, namely localized “hot spot” heating, are relatively well understood, but are difficult to quantify. A transformer GMD impact assessment must consider GIC amplitude, duration, and transformer physical characteristics such as design and condition (e.g., age, gas content, and moisture in the oil). A single threshold value of GIC cannot be justified as a “pass or fail” screening criterion where “fail” means that the transformer will suffer damage. A single threshold value of GIC only makes sense in the context where “fail” means that a more detailed study is required ~~and that “pass” means that GIC in a particular transformer is so low that a detailed study is unnecessary.~~ Such a threshold would have to be technically justifiable and sufficiently low to be considered a conservative value ~~within the scope of the benchmark of GIC.~~

The following considerations should be taken into account when assessing the thermal susceptibility of a transformer to half-cycle saturation:

- In the absence of manufacturer specific information, use the temperature limits for safe transformer operation such as those suggested in the IEEE Std C57.91-2011 [standard \[1\] \(IEEE Guide for Loading Mineral-oil-immersed Transformers and Step-voltage Regulators\)](#) for hot spot heating during short-

term emergency operation- [1]. This standard does not suggest that exceeding these limits will result in transformer failure, but rather that it will result in additional aging of cellulose in the paper-oil insulation and the potential for the generation of gas bubbles in the bulk oil. Thus, from the point of view of evaluating possible transformer damage due to increased hot spot heating, these thresholds can be considered conservative for a transformer in good operational condition.

- The worst case temperature rise for winding and metallic part (e.g., tie plate) heating should be estimated taking into consideration the construction characteristics of the transformer as they pertain to dc flux offset in the core (e.g., single-phase, shell, 5 and 3-leg three-phase construction).
- Bulk oil temperature due to ambient temperature and transformer loading must be added to the incremental temperature rise caused by hot spot heating. For planning purposes, maximum ambient and loading temperature should be used unless there is a technically justified reason to do otherwise.
- The time series or “[waveshapewaveform](#)” of the reference GMD event in terms of peak amplitude, duration, and frequency of the geoelectric field has an important effect on hot spot heating. Winding and metallic part hot spot heating have different thermal time constants, and their temperature rise will be different if the GIC currents are sustained for 2, 10, or 30 minutes for a given GIC peak amplitude.
- The “effective” GIC in autotransformers (reflecting the different GIC ampere-turns in the common and the series windings) must be used in the assessment. The effective current  $I_{dc,eq}$  in an autotransformer is defined by [2].

$$I_{dc,eq} = I_H + (I_N / 3 - I_H) V_X / V_H \quad (1)$$

where

- $I_H$  is the dc current in the high voltage winding;
- $I_N$  is the neutral dc current;
- $V_H$  is the rms rated voltage at HV terminals;
- $V_X$  is the rms rated voltage at the LV terminals.

## Transformer Thermal Impact Assessment Process

A simplified thermal assessment may be based on [Table 2](#) the appropriate tables from the “Screening Criterion for Transformer Thermal Impact Assessment” white paper [7]. ~~This~~<sup>4</sup> Each table, ~~shown as Table 1~~ below, provides the peak metallic hot spot temperatures that can be reached [for the given GMD event](#) using conservative thermal models. To use [Table 1](#) each table, one must select the bulk oil temperature and the threshold for metallic hot spot heating, for instance, from reference [1] after

<sup>4</sup> [Table 1 in the Screening Criterion for Transformer Thermal Impact Assessment white paper provides upper bound temperatures for the benchmark GMD event. Table 2 in the Screening Criterion for Transformer Thermal Impact Assessment white paper provides upper bound temperatures for the supplemental GMD event.](#)

allowing for possible de-rating due to transformer condition. If the effective GIC results in higher than threshold temperatures, then the use of a detailed thermal assessment as described below should be carried out.<sup>5</sup>

**Table 1: Upper Bound of Peak Metallic Hot Spot Temperatures Calculated Using the Benchmark GMD Event**

Effective GIC (A/phase)	Metallic hot spot Temperature (°C)	Effective GIC (A/phase)	Metallic hot spot Temperature (°C)
0	80	100	182
10	107	110	186
20	128	120	190
30	139	130	193
40	148	140	204
50	157	150	213
60	169	160	221
70	170	170	230
75	172	180	234
80	175	190	241
90	179	200	247

**Table 2: Upper Bound of Peak Metallic Hot Spot Temperatures Calculated Using the Supplemental GMD Event**

Effective GIC (A/phase)	Metallic hot spot Temperature (°C)	Effective GIC(A/phase)	Metallic hot spot Temperature (°C)
<u>0</u>	<u>80</u>	<u>120</u>	<u>188</u>
<u>10</u>	<u>107</u>	<u>130</u>	<u>191</u>
<u>20</u>	<u>124</u>	<u>140</u>	<u>194</u>
<u>30</u>	<u>137</u>	<u>150</u>	<u>198</u>
<u>40</u>	<u>147</u>	<u>160</u>	<u>203</u>
<u>50</u>	<u>156</u>	<u>170</u>	<u>209</u>
<u>60</u>	<u>161</u>	<u>180</u>	<u>214</u>
<u>70</u>	<u>162</u>	<u>190</u>	<u>229</u>
<u>75</u>	<u>165</u>	<u>200</u>	<u>237</u>
<u>80</u>	<u>169</u>	<u>220</u>	<u>248</u>
<u>85</u>	<u>172</u>	<u>230</u>	<u>253</u>

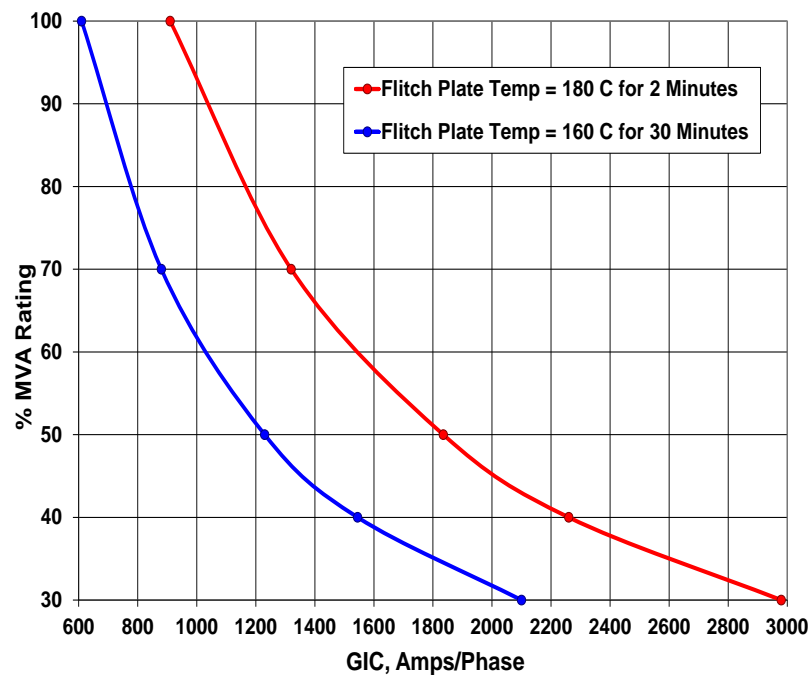
<sup>5</sup> Effective GIC in the table is the peak GIC(t) for the GMD event being assessed. Peak GIC(t) is not steady-state GIC.

<a href="#">90</a>	<a href="#">177</a>	<a href="#">250</a>	<a href="#">276</a>
<a href="#">100</a>	<a href="#">181</a>	<a href="#">275</a>	<a href="#">298</a>
<a href="#">110</a>	<a href="#">185</a>	<a href="#">300</a>	<a href="#">316</a>

Two different ways to carry out a detailed thermal impact assessment are discussed below. In addition, other approaches and models approved by international standard-setting organizations such as the Institute of Electrical and Electronic Engineers (IEEE) or International Council on Large Electric Systems (CIGRE) may also provide technically justified methods for performing thermal assessments.<sup>6</sup> All thermal assessment methods should be demonstrably equivalent to assessments that use the [benchmark GMD event-GMD events associated with TPL-007-2](#).

1. [Transformer manufacturer GIC capability curves](#). These curves relate permissible peak GIC (obtained by the user from a steady-state GIC calculation) and loading, for a specific transformer. An example of manufacturer capability curves is provided in **Figure 2**. Presentation details vary between manufacturers, and limited information is available regarding the assumptions used to generate these curves, in particular, the assumed waveshape or duration of the effective GIC. Some manufacturers assume that the [waveshapewaveform](#) of the GIC in the transformer windings is a square pulse of 2, 10, or 30 minutes in duration. In the case of the transformer capability curve shown in **Figure 2-3**, a square pulse of 900 A/phase with a duration of 2 minutes would cause the Flitch plate hot spot to reach a temperature of 180°C at full load. [5]. While GIC capability curves are relatively simple to use, an amount of engineering judgment is necessary to ascertain which portion of a GIC [waveshapewaveform](#) is equivalent to, for example, a 2 minute pulse. Also, manufacturers generally maintain that in the absence of transformer standards defining thermal duty due to GIC, such capability curves must be developed for every transformer design and vintage.

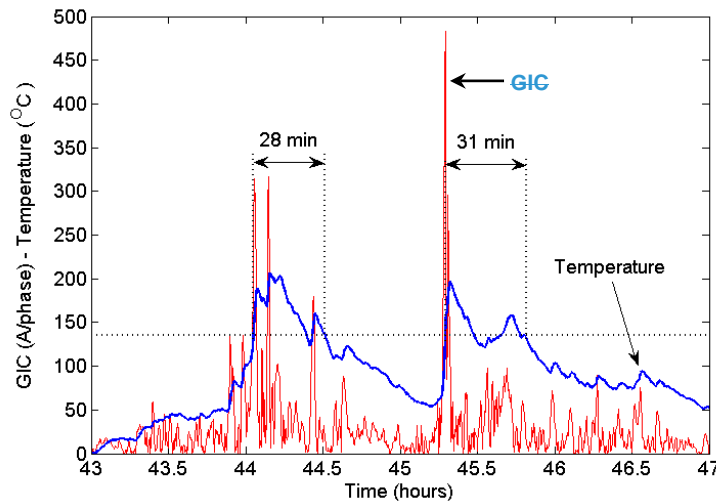
<sup>6</sup> For example, C57.163-2015 – IEEE Guide for Establishing Power Transformer Capability while under Geomagnetic Disturbances. [4]



**Figure 2: Sample GIC Manufacturer Capability Curve of a Large Single-Phase Transformer Design using the Flitch Plate Temperature Criteria [35]**

2. Thermal response simulation<sup>7</sup>. The input to this type of simulation is the time series or [waveshapewaveform](#) of effective GIC flowing through a transformer (taking into account the actual configuration of the system), and the result of the simulation is the hot spot temperature (winding or metallic part) time sequence for a given transformer. An example of GIC input and hot spot temperature time series values from [46] are shown in **Figure 3**. The hot spot thermal transfer functions can be obtained from measurements or calculations provided by transformer manufacturers. Conservative default values can be used (e.g., those provided in [46]) when specific data are not available. Hot spot temperature thresholds shown in **Figure 3** are consistent with IEEE Std C57.91-2011 emergency loading hot spot limits. Emergency loading time limit is usually 30 minutes.

<sup>7</sup> Technical details of this methodology can be found in [46].



**Figure 3: Sample Tie Plate Temperature Calculation**

Blue trace is incremental temperature and red trace is the magnitude of the GIC/phase [4]-[6]

It is important to reiterate that the characteristics of the time sequence or “[waveshapewaveform](#)” are very important in the assessment of the thermal impact of GIC on transformers. Transformer hot spot heating is not instantaneous. The thermal time constants of transformer windings and metallic parts are typically on the order of minutes to tens of minutes; therefore, hot spot temperatures are heavily dependent on GIC history and rise time, amplitude and duration of GIC in the transformer windings, bulk oil temperature due to loading, ambient temperature and cooling mode.

#### Calculation of the GIC [WaveshapeWaveform](#) for a Transformer

The following procedure can be used to generate time series GIC data  $GIC(t)$  (i.e.,  $GIC(t)$ ) using a software program capable of computing GIC in the steady-state. The steps are as follows:

1. Calculate contribution of GIC due to eastward and northward geoelectric fields for the transformer under consideration;
2. Scale the GIC contribution according to the reference geoelectric field time series to produce the GIC time series for the transformer under consideration.

Most available GIC-capable software packages can calculate GIC in steady-state in a transformer assuming a uniform eastward geoelectric field of 1 V/km ( $GIC_E$ ) while the northward geoelectric field is zero. Similarly,  $GIC_N$  can be obtained for a uniform northward geoelectric field of 1 V/km while the eastward geoelectric field is zero.  $GIC_E$  and  $GIC_N$  are the normalized GIC contributions for the transformer under consideration.

If the earth conductivity is assumed to be uniform (or laterally uniform) in the transmission system of interest, then the transformer GIC (in A/phase) for any value of  $E_E(t)$  and  $E_N(t)$  can be calculated using (2) [2].

$$GIC(t) = |E(t)| \cdot \{GIC_E \sin(\varphi(t)) + GIC_N \cos(\varphi(t))\} \quad (2)$$

where

$$|E(t)| = \sqrt{E_N^2(t) + E_E^2(t)} \quad (3)$$

$$\varphi(t) = \tan^{-1} \left( \frac{E_E(t)}{E_N(t)} \right) \quad (4)$$

$$GIC(t) = E_E(t) \cdot GIC_E + E_N(t) \cdot GIC_N \quad (5)$$

$GIC_N$  is the effective GIC due to a northward geoelectric field of 1 V/km, and  $GIC_E$  is the effective GIC due to an eastward geoelectric field of 1 V/km. The units for  $GIC_N$  and  $GIC_E$  are A/phase/ per V/km)

The geoelectric field time series  $E_N(t)$  and  $E_E(t)$  is obtained, for instance, from the reference geomagnetic field time series [\[5\] \(from \[7\] and/or \[8\]\)](#) after the appropriate geomagnetic latitude scaling factor  $\alpha$  is applied<sup>8</sup>. The reference geoelectric field time series is calculated using the reference earth model. When using this geoelectric field time series where a different earth model is applicable, it should be scaled with the [appropriate](#) conductivity scaling factor  $\beta$ <sup>9</sup>. Alternatively, the geoelectric field can be calculated from the reference geomagnetic field time series after the appropriate geomagnetic latitude scaling factor  $\alpha$  is applied and the appropriate earth model is used. In such case, the conductivity scaling factor  $\beta$  is not applied because it is already accounted for by the use of the appropriate earth model.

Applying (5) to each point in  $E_N(t)$  and  $E_E(t)$  results in  $GIC(t)$ .

### GIC(t) Calculation Example

Let us assume that from the steady-state solution, the effective GIC in this transformer is  $GIC_E = -20$  A/phase if  $E_N=0$ ,  $E_E=1$  V/km and  $GIC_N = 26$  A/phase if  $E_N=1$  V/km,  $E_E=0$ . Let us also assume the geomagnetic field time series corresponds to a geomagnetic latitude where  $\alpha = 1$  and that the earth conductivity corresponds to the reference earth model in [\[57\]](#). The resulting geoelectric field time series is shown in **Figure 4**. Therefore:

$$GIC(t) = E_E(t) \cdot GIC_E + E_N(t) \cdot GIC_N \text{ (A/phase)} \quad (6)$$

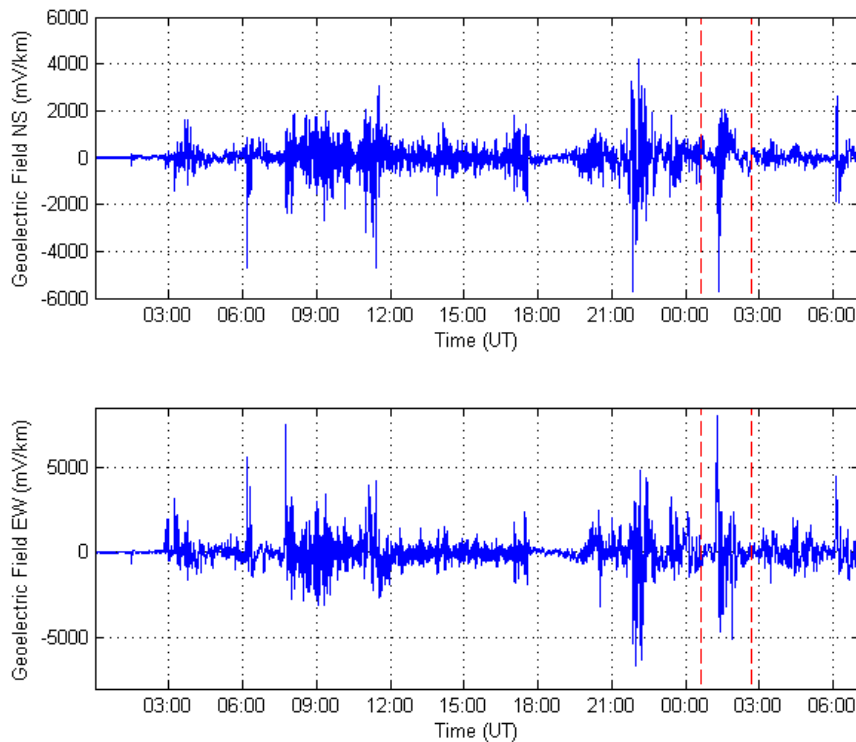
$$GIC(t) = -E_E(t) \cdot 20 + E_N(t) \cdot 26 \text{ (A/phase)} \quad (7)$$

<sup>8</sup> The geomagnetic factor  $\alpha$  is described in [2] and is used to scale the geomagnetic field according to geomagnetic latitude. The lower the geomagnetic latitude (closer to the equator), the lower the amplitude of the geomagnetic field.

<sup>9</sup> The conductivity scaling factor  $\beta$  is described in [2], and is used to scale the geoelectric field according to the conductivity of different physiographic regions. Lower conductivity results in higher  $\beta$  scaling factors.

The resulting GIC [wvshapewaveform](#) GIC(t) is shown in **Figures 5 and 6** and can subsequently be used for thermal analysis.

It should be emphasized that even for the same reference event, the GIC(t) [wvshapewaveform](#) in every transformer will be different, depending on the location within the system and the number and orientation of the circuits connecting to the transformer station. Assuming a single generic GIC(t) [wvshapewaveform](#) to test all transformers is incorrect.

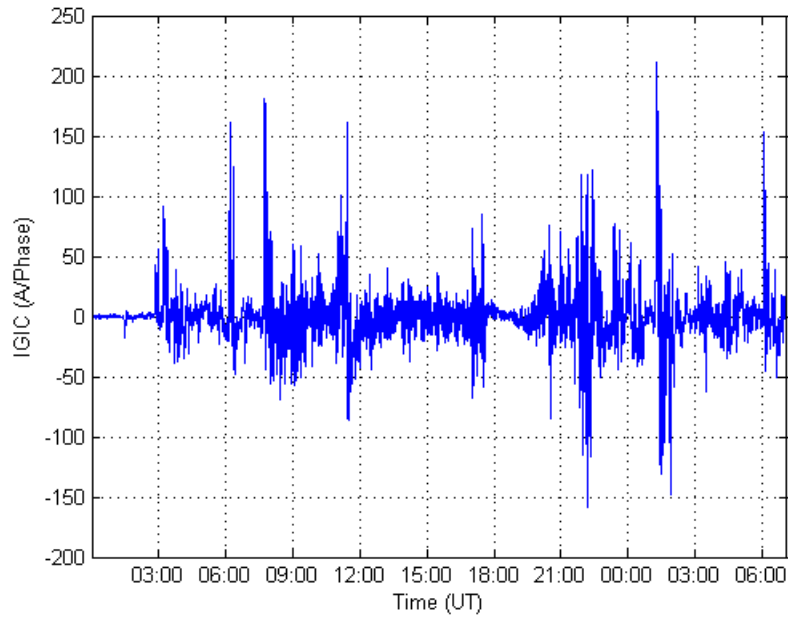


**Figure 4: Calculated Goelectric Field  $E_N(t)$  and  $E_E(t)$  Assuming  $\alpha=1$  and  $\beta=1$  (Reference Earth Model).**

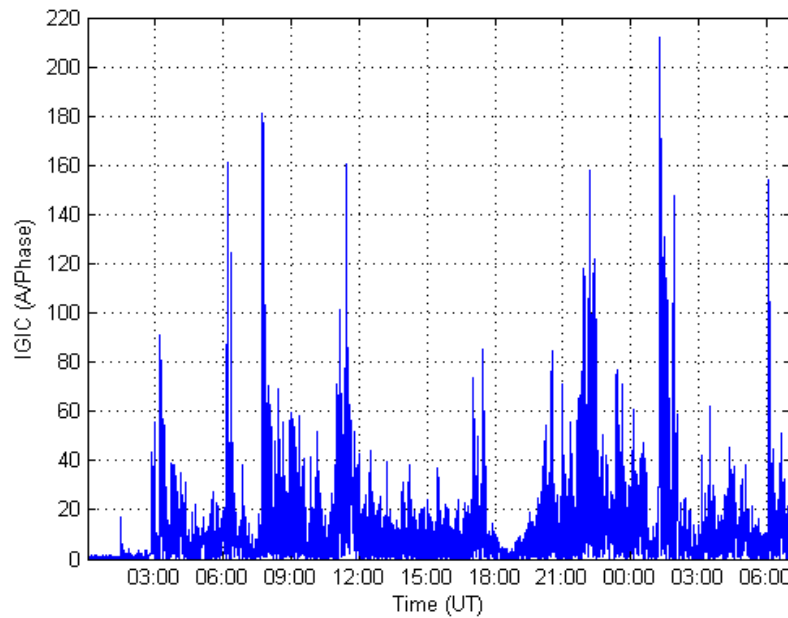
Zoom area for subsequent graphs is highlighted.

Dashed lines approximately show the close-up area for subsequent Figures.





**Figure 5: Calculated GIC(t) Assuming  $\alpha=1$  and  $\beta=1$**   
 ←Reference Earth Model→



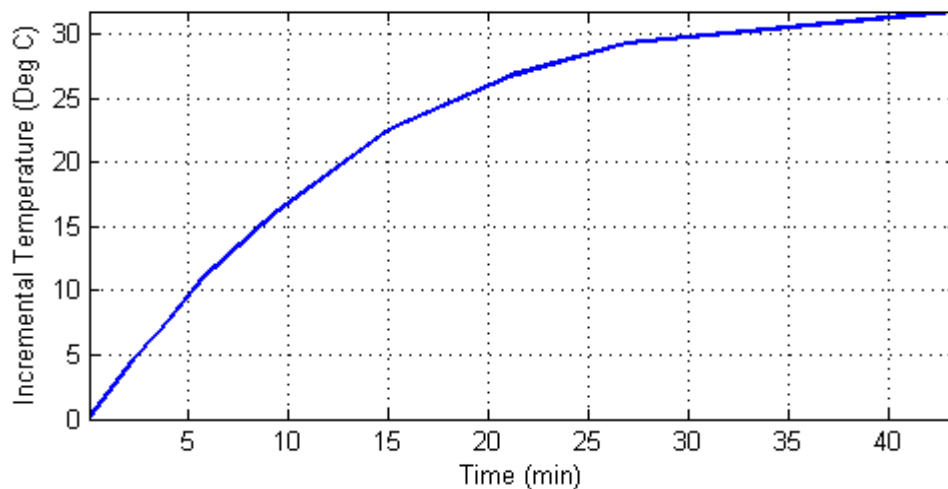
**Figure 6: Calculated Magnitude of GIC(t) Assuming  $\alpha=1$  and  $\beta=1$**   
 ←Reference Earth Model→

**Transformer Thermal Assessment Examples**

There are two basic ways to carry out a transformer thermal analysis once the GIC time series  $GIC(t)$  is known for a given transformer: 1) calculating the thermal response as a function of time; and 2) using manufacturer's capability curves.

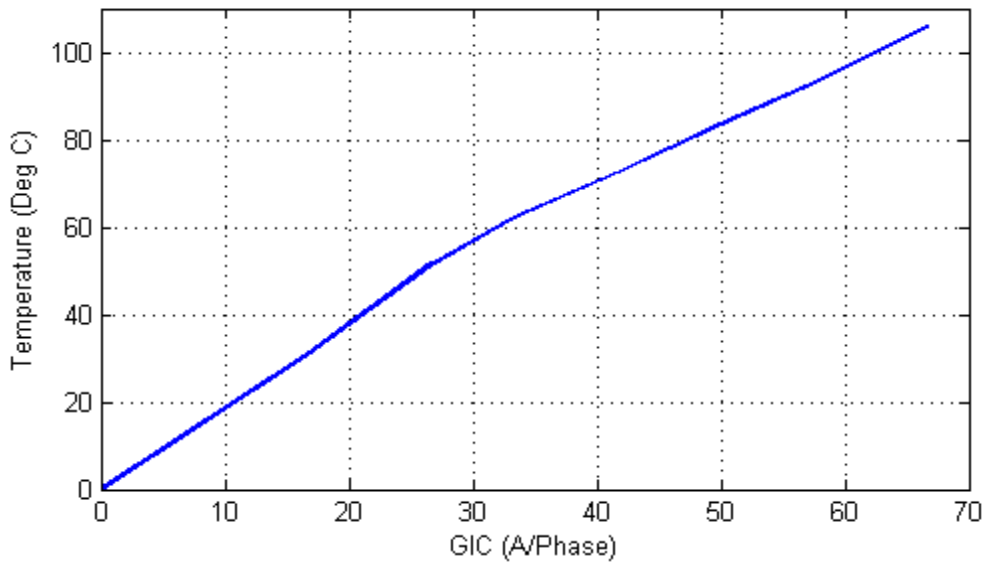
**Example 1: Calculating thermal response as a function of time using a thermal response tool**

The thermal step response of the transformer can be obtained for both winding and metallic part hot spots from: 1) measurements; 2) manufacturer's calculations; or 3) generic published values. **Figure 7** shows the measured metallic hot spot thermal response to a dc step of 16.67 A/phase of the top yoke clamp from [69] that will be used in this example. **Figure 8** shows the measured incremental temperature rise (asymptotic response) of the same hot spot to long duration GIC steps.<sup>10</sup>



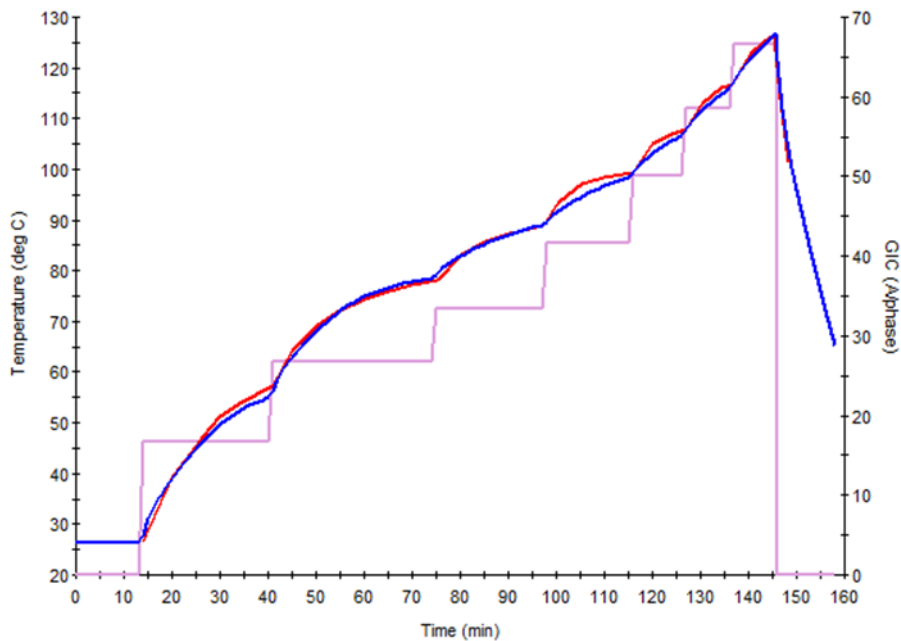
**Figure 7: Thermal Step Response to a 16.67 Amperes per Phase dc Step**  
Metallic hot spot heating-

<sup>10</sup> Heating of bulk oil due to the hot spot temperature increase is not included in the asymptotic response because the time constant of bulk oil heating is at least an order of magnitude larger than the time constants of hot spot heating.



**Figure 8: Asymptotic Thermal Step Response**  
Metallic hot spot heating-

The step response in **Figure 7** was obtained from the first GIC step of the tests carried out in [6]. The asymptotic thermal response in **Figure 8** was obtained from the final or near-final temperature values after each subsequent GIC step. **Figure 9** shows a comparison between measured temperatures and the calculated temperatures using the thermal response model used in the rest of this discussion.



**Figure 9: Comparison of measured temperatures (red trace) and simulation results (blue trace).**

Injected current is represented by the magenta trace.

To obtain the thermal response of the transformer to a GIC [waveshapewaveform](#) such as the one in **Figure 6**, a thermal response model is required. To create a thermal response model, the measured or manufacturer-calculated transformer thermal step responses (winding and metallic part) for various GIC levels are required. The GIC(t) time series or [waveshapewaveform](#) is then applied to the thermal model to obtain the incremental temperature rise as a function of time  $\theta(t)$  for the GIC(t) [waveshapewaveform](#). The total temperature is calculated by adding the oil temperature, for example, at full load.

Figure 10 illustrates the calculated GIC(t) and the corresponding [metallic](#) hot spot temperature time series  $\theta(t)$ . Figure 11 illustrates a close-up view of the peak transformer temperatures calculated in this example.

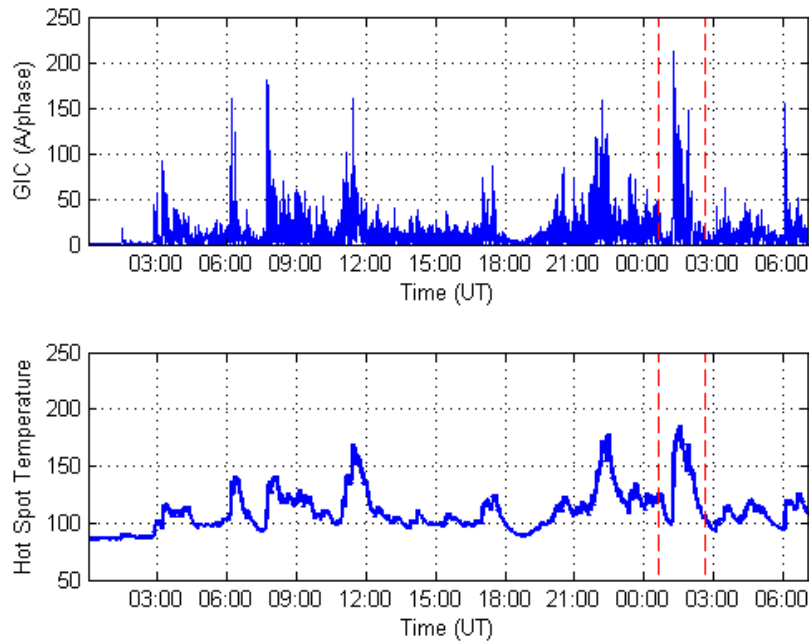
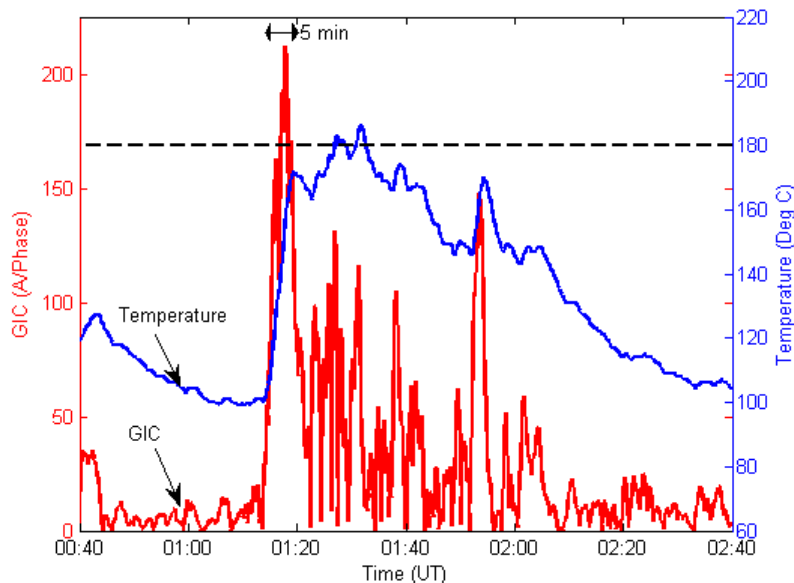


Figure 10: Magnitude of GIC(t) and Metallic Hot Spot Temperature  $\theta(t)$  Assuming Full Load Oil Temperature of 85.3°C (40°C ambient). Dashed lines approximately show the close-up area for subsequent Figures.



### Figure 11: Close-up of Metallic Hot Spot Temperature Assuming a Full Load

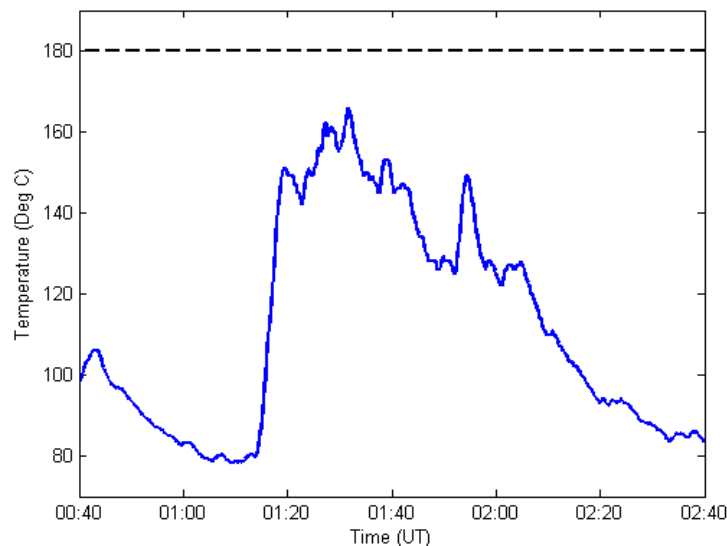
{Blue trace is  $\theta(t)$ . Red trace is  $GIC(t)$ }

In this example, the IEEE Std C57.91-2011 emergency loading hot spot threshold of 200°C for metallic hot spot heating is not exceeded. Peak temperature is 186°C. The IEEE standard is silent as to whether the temperature can be higher than 200°C for less than 30 minutes. Manufacturers can provide guidance on individual transformer capability.

It is not unusual to use a lower temperature threshold of 180°C to account for calculation and data margins, as well as transformer age and condition. **Figure 11** shows that 180°C will be exceeded for 5 minutes.

At 75% loading, the initial temperature is 64.6°C rather than 85.3°C, and the hot spot temperature peak is 165°C, well below the 180°C threshold (see **Figure 12**).

If a conservative threshold of 160°C were used to account for the age and condition of the transformer, then the full load limits would be exceeded for approximately 22 minutes.

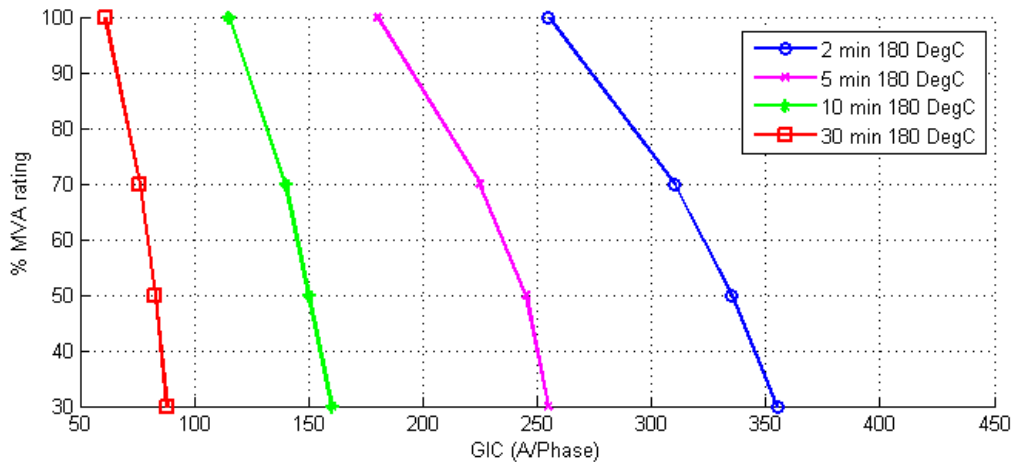


### Figure 12: Close-up of Metallic Hot Spot Temperature Assuming a 75% Load

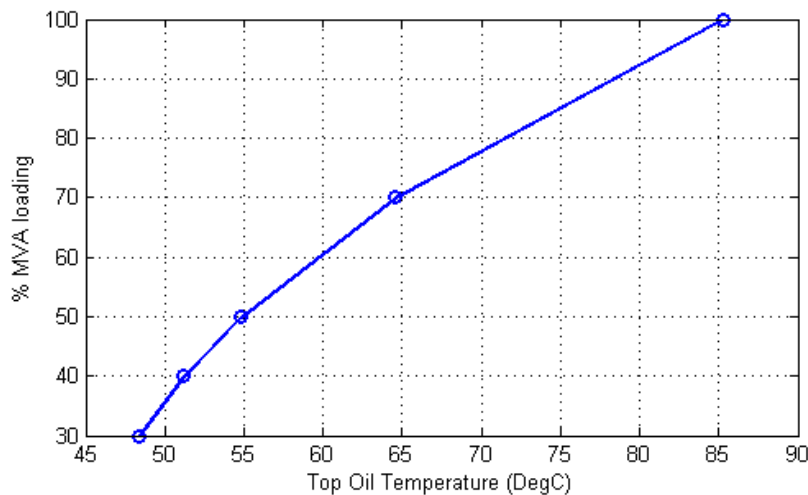
{Oil temperature of 64.5°C}

**Example 2: Using a Manufacturer's Capability Curves**

The capability curves used in this example are shown in **Figure 13**. To maintain consistency with the previous example, these particular capability curves have been reconstructed from the thermal step response shown in **Figures 7 and 8**, and the simplified loading curve shown in **Figure 14** (calculated using formulas from IEEE Std C57.91-2011).



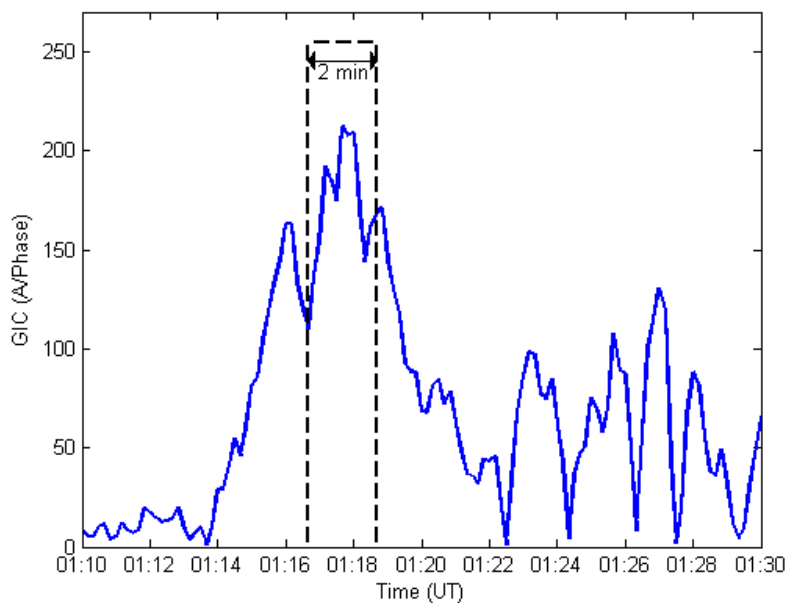
**Figure 13: Capability Curve of a Transformer Based on the Thermal Response Shown in Figures 8 and 9.**



**Figure 14: Simplified Loading Curve Assuming 40°C Ambient Temperature.**

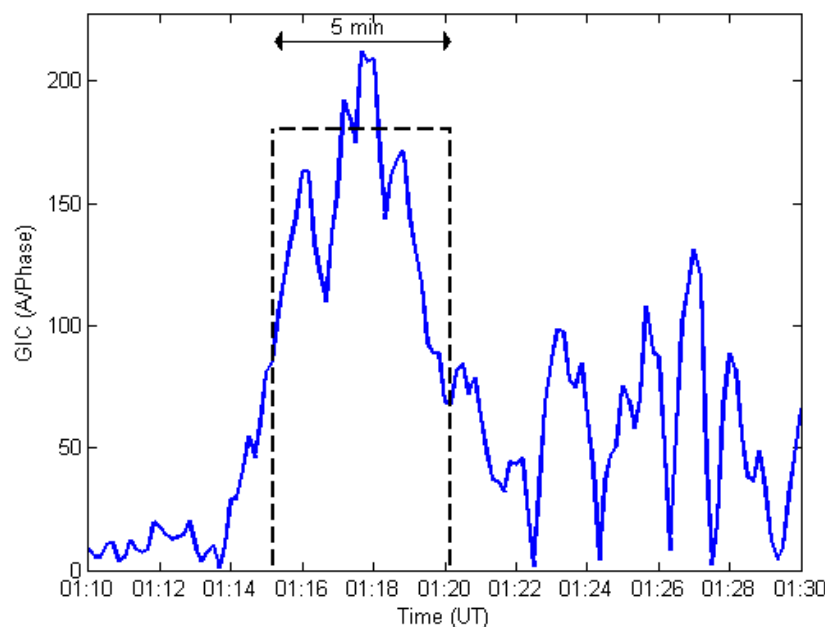
The basic notion behind the use of capability curves is to compare the calculated GIC in a transformer with the limits at different GIC pulse widths. A narrow GIC pulse has a higher limit than a longer duration or wider one. If the calculated GIC and assumed pulse width falls below the appropriate pulse width curve, then the transformer is within its capability.

To use these curves, it is necessary to estimate an equivalent square pulse that matches the [wavelength](#) of GIC(t), generally at a GIC(t) peak. **Figure 15** shows a close-up of the GIC near its highest peak superimposed to a 255 Amperes per phase, 2 minute pulse at 100% loading from **Figure 13**. Since a narrow 2-minute pulse is not representative of GIC(t) in this case, a 5 minute pulse with an amplitude of 180 A/phase at 100% loading has been superimposed on **Figure 16**. It should be noted that a 255 A/phase, 2 minute pulse is equivalent to a 180 A/phase 5 minute pulse from the point of view of transformer capability. Deciding what GIC pulse is equivalent to the portion of GIC(t) under consideration is a matter of engineering judgment.



**Figure 15: Close-up of GIC(t) and a 2 minute 255 A/phase GIC pulse at full load**



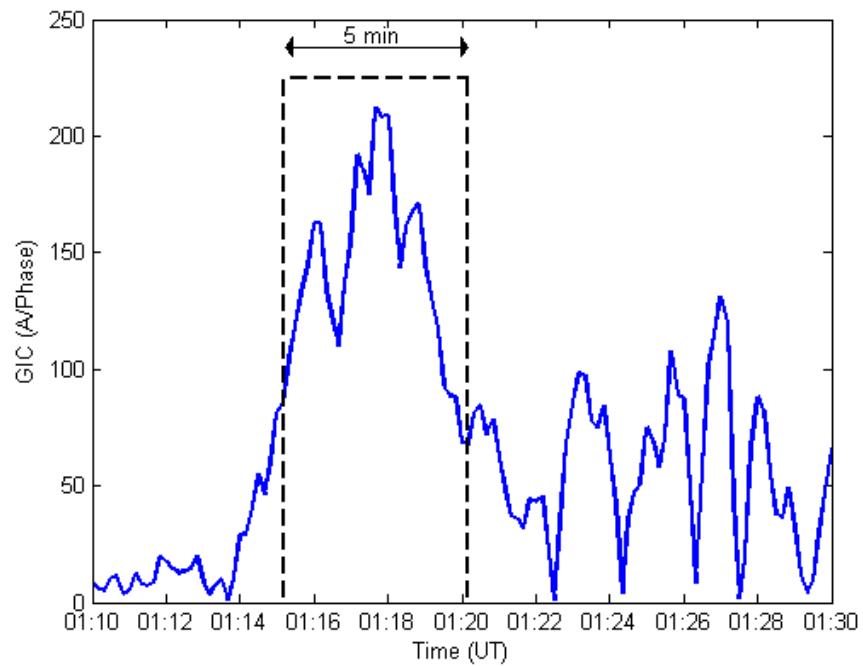


**Figure 16: Close-up of GIC(t) and a Five Minute 180 A/phase GIC Pulse at Full Load**

When using a capability curve, it should be understood that the curve is derived assuming that there is no hot spot heating due to prior GIC at the time the GIC pulse occurs (only an initial temperature due to loading). Therefore, in addition to estimating the equivalent pulse that matches GIC(t), prior [metallic](#) hot spot heating must be accounted for. From these considerations, it is unclear whether the capability curves would be exceeded at full load with a 180°C threshold in this example.

At 70% loading, the two and five minute pulses from **Figure 13** would have amplitudes of 310 and 225 A/phase, respectively. The 5 minute pulse is illustrated in **Figure 17**. In this case, judgment is also required to assess if the GIC(t) is within the capability curve for 70% loading. In general, capability curves are easier to use when GIC(t) is substantially above, or clearly below the GIC thresholds for a given pulse duration.

If a conservative threshold of 160°C were used to account for the age and condition of the transformer, then a new set of capability curves would be required.



**Figure 17: Close-up of GIC(t) and a 5 Minute 225 A/phase GIC Pulse Assuming 75% Load**

## References

- [1] "IEEE Guide for loading mineral-oil-immersed transformers and step-voltage regulators." IEEE Std C57.91-2011 (Revision of IEEE Std C57.91-1995).
- [2] Application Guide: Computing Geomagnetically-Induced Current in the Bulk-Power System, NERC. Available at:  
[http://www.nerc.com/comm/PC/Geomagnetic%20Disturbance%20Task%20Force%20GMDTF%202013/GIC%20Application%20Guide%202013\\_approved.pdf](http://www.nerc.com/comm/PC/Geomagnetic%20Disturbance%20Task%20Force%20GMDTF%202013/GIC%20Application%20Guide%202013_approved.pdf)
- [3] ~~"Screening Criterion for Transformer Thermal Impact Assessment". Developed by the Project 2013-03 (Geomagnetic Disturbance) standard drafting team. Available at:~~  
<http://www.nerc.com/pa/stand/Pages/TPL0071RI.aspx>
- [4] ~~"IEEE Guide for Establishing Power Transformer Capability while under Geomagnetic Disturbances." IEEE Std C57.163-2015~~
- [3][5] Girgis, R.; Vedante, K. "Methodology for evaluating the impact of GIC and GIC capability of power transformer designs." IEEE PES 2013 General Meeting Proceedings. Vancouver, Canada.
- [4][6] Marti, L., Rezaei-Zare, A., Narang, A. "Simulation of Transformer Hotspot Heating due to Geomagnetically Induced Currents." IEEE Transactions on Power Delivery, vol.28, no.1. pp 320-327. January 2013.
- [5][7] Benchmark Geomagnetic Disturbance Event Description white paper. Developed by the Project 2013-03 (Geomagnetic Disturbance) standard drafting team. Available at:  
<http://www.nerc.com/pa/stand/Pages/TPL0071RI.aspx>
- [8] ~~Supplemental Geomagnetic Disturbance Event Description white paper. Developed by the Project 2013-03 (Geomagnetic Disturbance) standard drafting team. Available at:~~  
<http://www.nerc.com/pa/Stand/Pages/Project-2013-03-Geomagnetic-Disturbance-Mitigation.aspx>
- [6][9] Lahtinen, Matti. Jarmo Elovaara. "GIC occurrences and GIC test for 400 kV system transformer". IEEE Transactions on Power Delivery, Vol. 17, No. 2. April 2002.
- [7][1] ~~"Screening Criterion for Transformer Thermal Impact Assessment". Developed by the Project 2013-03 (Geomagnetic Disturbance) standard drafting team. Available at:~~  
<http://www.nerc.com/pa/Stand/Pages/Project-2013-03-Geomagnetic-Disturbance-Mitigation.aspx>

# Unofficial Comment Form

## Project 2013-03 Geomagnetic Disturbance Mitigation

**DO NOT** use this form for submitting comments. Use the [electronic form](#) to submit comments on proposed **TPL-007-2 – Transmission System Planned Performance for Geomagnetic Disturbance Events**. The electronic comment form must be completed by **8:00 p.m. Eastern, Friday, August 11, 2017**.

Documents and information about this project are available on the [project page](#). If you have any questions, contact Standards Developer, [Mark Olson](#) (via email), or at (404) 446-9760.

### Background Information

On September 22, 2016, the Federal Energy Regulatory Commission (FERC) issued Order No. 830 approving Reliability Standard TPL-007-1 – Transmission System Planned Performance for Geomagnetic Disturbance Events. In the order, FERC directed NERC to develop certain modifications to the Standard, including:

- Modify the benchmark geomagnetic disturbance (GMD) event definition used for GMD Vulnerability Assessments;
- Make related modifications to requirements pertaining to transformer thermal impact assessments;
- Require collection of GMD-related data; and
- Require deadlines for Corrective Action Plans (CAPs) and GMD mitigating actions.

FERC established a deadline of 18 months from the effective date of Order No. 830 for completing the revisions, which is May 2018.

The standard drafting team (SDT) has developed proposed TPL-007-2 to address the above directives.

### Questions

You do not have to answer all questions. Enter comments in simple text format. Bullets, numbers, and special formatting will not be retained.

1. The SDT developed proposed Requirements R8 – R10 and the supplemental GMD event to address FERC concerns with the benchmark GMD event used in GMD Vulnerability Assessments. (Order No. 830 P.44, P.47-49, P.65). The requirements will obligate responsible entities to perform a supplemental GMD Vulnerability Assessment based on the supplemental GMD event that accounts for potential impacts of localized peak geoelectric fields. Do you agree with the proposed requirements? If you do not agree, or if

you agree but have comments or suggestions for the proposed requirements provide your recommendation and explanation.

Yes

No

Comments:

2. The SDT developed the *Supplemental GMD Event Description* white paper to provide technical justification for the supplemental GMD event. The purpose of the supplemental GMD event description is to provide a defined event for assessing system performance for a GMD event which includes a local enhancement of the geomagnetic field. Do you agree with the proposed supplemental GMD event and the description in the white paper? If you do not agree, or if you agree but have comments or suggestions for the supplemental GMD event and the description in the white paper provide your recommendation and explanation.

Yes

No

Comments:

3. The SDT established an 85 A per phase screening criterion for determining which power transformers are required to be assessed for thermal impacts from a supplemental GMD event in Requirement R10. Justification for this threshold is provided in the revised *Screening Criterion for Transformer Thermal Impact Assessment* white paper. Do you agree with the proposed 85 A per phase screening criterion and the technical justification for this criterion that has been added to the white paper? If you do not agree, or if you agree but have comments or suggestions for the screening criterion and revisions to the white paper provide your recommendation and explanation.

Yes

No

Comments:

4. The SDT revised the *Transformer Thermal Impact Assessment* white paper to include the supplemental GMD event. Do you agree with the revisions to the white paper? If you do not agree, or if you agree but have comments or suggestions on the revisions to the white paper provide your recommendation and explanation.

Yes

No

Comments:

5. The SDT developed proposed Requirement R7 to address FERC directives in Order No. 830 for establishing Corrective Action Plan (CAP) deadlines associated with GMD Vulnerability Assessments (P. 101, 102). Do you agree with the proposed requirement? If you do not agree, or if you agree but have comments or suggestions for the proposed requirement provide your recommendation and explanation.

Yes

No

Comments:

6. The SDT developed Requirements R11 and R12 to address FERC directives in Order No. 830 for requiring responsible entities to collect GIC monitoring and magnetometer data (P. 88; P. 90-92). Do you agree with the proposed requirements? If you do not agree, or if you agree but have comments or suggestions for the proposed requirements provide your recommendation and explanation.

Yes

No

Comments:

7. Do you agree with the proposed Implementation Plan for TPL-007-2? If you do not agree, or if you agree but have comments or suggestions for the Implementation Plan provide your recommendation and explanation.

Yes

No

Comments:

8. Do you agree with the Violation Risk Factors (VRFs) and Violation Severity Levels (VSLs) for the requirements in proposed TPL-007-2? If you do not agree, or if you agree but have comments or suggestions for the VRFs and VSLs provide your recommendation and explanation.

Yes

No

Comments:

9. The SDT believes proposed TPL-007-2 provide entities with flexibility to meet the reliability objectives in the project Standards Authorization Request (SAR) in a cost effective manner. Do you agree? If you do not agree, or if you agree but have suggestions for improvement to enable additional cost effective approaches to meet the reliability objectives, please provide your recommendation and, if appropriate, technical justification.

Yes

No

Comments:

10. Provide any additional comments for the SDT to consider, if desired.

Comments:

# Violation Risk Factor and Violation Severity Level

## Justifications

### TPL-007-2 – Transmission System Planned Performance for Geomagnetic Disturbance Events

This document provides the Standard Drafting Team's (SDT) justification for assignment of Violation Risk Factors (VRFs) and Violation Severity Levels (VSLs) for each requirement in TPL-007-2 – Transmission System Planned Performance for Geomagnetic Disturbance Events. Each requirement is assigned a VRF and a VSL. These elements support the determination of an initial value range for the Base Penalty Amount regarding violations of requirements in FERC-approved Reliability Standards, as defined in the ERO Sanction Guidelines. The SDT applied the following NERC criteria and FERC Guidelines when proposing VRFs and VSLs for the requirements under this project.

### NERC Criteria - Violation Risk Factors

#### High Risk Requirement

A requirement that, if violated, could directly cause or contribute to Bulk Electric System instability, separation, or a cascading sequence of failures, or could place the Bulk Electric System at an unacceptable risk of instability, separation, or cascading failures; or, a requirement in a planning time frame that, if violated, could, under emergency, abnormal, or restorative conditions anticipated by the preparations, directly cause or contribute to Bulk Electric System instability, separation, or a cascading sequence of failures, or could place the Bulk Electric System at an unacceptable risk of instability, separation, or cascading failures, or could hinder restoration to a normal condition.

#### Medium Risk Requirement

A requirement that, if violated, could directly affect the electrical state or the capability of the Bulk Electric System, or the ability to effectively monitor and control the Bulk Electric System. However, violation of a medium risk requirement is unlikely to lead to Bulk Electric System instability, separation, or cascading failures; or, a requirement in a planning time frame that, if violated, could, under emergency, abnormal, or restorative conditions anticipated by the preparations, directly and adversely affect the electrical state or capability of the Bulk Electric System, or the ability to effectively monitor, control, or restore the Bulk Electric System. However, violation of a medium risk requirement is unlikely, under emergency, abnormal, or restoration conditions anticipated by the preparations, to lead to Bulk Electric System instability, separation, or cascading failures, nor to hinder restoration to a normal condition.



### **Lower Risk Requirement**

A requirement that is administrative in nature and a requirement that, if violated, would not be expected to adversely affect the electrical state or capability of the Bulk Electric System, or the ability to effectively monitor and control the Bulk Electric System; or, a requirement that is administrative in nature and a requirement in a planning time frame that, if violated, would not, under the emergency, abnormal, or restorative conditions anticipated by the preparations, be expected to adversely affect the electrical state or capability of the Bulk Electric System, or the ability to effectively monitor, control, or restore the Bulk Electric System.

## **FERC Violation Risk Factor Guidelines**

### **Guideline (1) – Consistency with the Conclusions of the Final Blackout Report**

The Commission seeks to ensure that VRFs assigned to Requirements of Reliability Standards in these identified areas appropriately reflect their historical critical impact on the reliability of the Bulk-Power System. In the VSL Order, FERC listed critical areas (from the Final Blackout Report) where violations could severely affect the reliability of the Bulk-Power System:

- Emergency operations
- Vegetation management
- Operator personnel training
- Protection systems and their coordination
- Operating tools and backup facilities
- Reactive power and voltage control
- System modeling and data exchange
- Communication protocol and facilities
- Requirements to determine equipment ratings
- Synchronized data recorders

- Clearer criteria for operationally critical facilities
- Appropriate use of transmission loading relief.

**Guideline (2) – Consistency within a Reliability Standard**

The Commission expects a rational connection between the sub-Requirement VRF assignments and the main Requirement VRF assignment.

**Guideline (3) – Consistency among Reliability Standards**

The Commission expects the assignment of VRFs corresponding to requirements that address similar reliability goals in different Reliability Standards would be treated comparably.

**Guideline (4) – Consistency with NERC’s Definition of the Violation Risk Factor Level**

Guideline (4) was developed to evaluate whether the assignment of a particular VRF level conforms to NERC’s definition of that risk level.

**Guideline (5) – Treatment of Requirements that Co-mingle More Than One Obligation**

Where a single Requirement co-mingles a higher risk reliability objective and a lesser risk reliability objective, the VRF assignment for such requirements must not be watered down to reflect the lower risk level associated with the less important objective of the Reliability Standard.

**NERC Criteria - Violation Severity Levels**

VSLs define the degree to which compliance with a requirement was not achieved. Each requirement must have at least one VSL. While it is preferable to have four VSLs for each requirement, some requirements do not have multiple “degrees” of noncompliant performance and may have only one, two, or three VSLs.

VSLs should be based on NERC’s overarching criteria shown in the table below:

Lower VSL	Moderate VSL	High VSL	Severe VSL
The performance or product measured almost meets the full intent of the requirement.	The performance or product measured meets the majority of the intent of the requirement.	The performance or product measured does not meet the majority of the intent of the requirement, but does meet some of the intent.	The performance or product measured does not substantively meet the intent of the requirement.

**FERC Order of Violation Severity Levels**

FERC’s VSL guidelines are presented below, followed by an analysis of whether the VSLs proposed for each requirement in the standard meet the FERC Guidelines for assessing VSLs:

**Guideline 1 – Violation Severity Level Assignments Should Not Have the Unintended Consequence of Lowering the Current Level of Compliance**

Compare the VSLs to any prior levels of non-compliance and avoid significant changes that may encourage a lower level of compliance than was required when levels of non-compliance were used.

**Guideline 2 – Violation Severity Level Assignments Should Ensure Uniformity and Consistency in the Determination of Penalties**

A violation of a “binary” type requirement must be a “Severe” VSL.  
Do not use ambiguous terms such as “minor” and “significant” to describe noncompliant performance.

**Guideline 3 – Violation Severity Level Assignment Should Be Consistent with the Corresponding Requirement**

VSLs should not expand on what is required in the requirement.

**Guideline 4 – Violation Severity Level Assignment Should Be Based on A Single Violation, Not on A Cumulative Number of Violations**

Unless otherwise stated in the requirement, each instance of non-compliance with a requirement is a separate violation. Section 4 of the Sanction Guidelines states that assessing penalties on a per-violation per-day basis is the “default” for penalty calculations.

<b>VRF Justifications – TPL-007-2, R1</b>	
<b>Proposed VRF</b>	<b>Low</b>
FERC VRF G1 Discussion	Guideline 1- Consistency w/ Blackout Report. N/A
FERC VRF G2 Discussion	Guideline 2- Consistency within a Reliability Standard. The requirement has no sub-requirements so a single VRF was assigned.
FERC VRF G3 Discussion	Guideline 3- Consistency among Reliability Standards. A VRF of Lower is consistent with Reliability Standard TPL-001-4 Requirement R7, which requires the Planning Coordinator, in conjunction with each of its Transmission Planners, to identify each entity’s individual and joint responsibilities for performing required studies for the Planning Assessment. Proposed TPL-007-2 Requirement R1 requires Planning Coordinators, in conjunction with Transmission Planners, to identify individual and joint responsibilities for maintaining models and performing studies needed to complete the benchmark and supplemental GMD Vulnerability Assessments, and implementing process(es) to obtain GMD measurement data as specified in the Standard.
FERC VRF G4 Discussion	Guideline 4- Consistency with NERC Definitions of VRFs. A VRF of Lower is consistent with the NERC VRF definition. The requirement for identifying individual and joint responsibilities of the Planning Coordinator and each of the Transmission Planners in the Planning Coordinator’s planning area for maintaining models, performing GMD studies, and obtaining GMD measurement data, if violated, would not be expected to adversely affect the electrical state or capability of the Bulk Electric System, or the ability to effectively monitor, control, or restore the Bulk Electric System under conditions of a GMD event.

**VRF Justifications – TPL-007-2, R1**

FERC VRF G5 Discussion

Guideline 5- Treatment of Requirements that Co-mingle More than One Obligation. The requirement contains one objective, therefore a single VRF is assigned.

<b>Proposed VSLs – TPL-007-2, R1</b>			
<b>Lower</b>	<b>Moderate</b>	<b>High</b>	<b>Severe</b>
N/A	N/A	N/A	The Planning Coordinator, in conjunction with its Transmission Planner(s), failed to determine and identify individual or joint responsibilities of the Planning Coordinator and Transmission Planner(s) in the Planning Coordinator’s planning area for maintaining models, performing the study or studies needed to complete benchmark and supplemental GMD Vulnerability Assessments, and implementing process(es) to obtain GMD measurement data as specified in the Standard.

VSL Justifications – TPL-007-2, R1	
NERC VSL Guidelines	Consistent with NERC's VSL Guidelines. The requirement does not have elements or quantities to evaluate degrees of compliance. A VSL of Severe is assigned for non-compliance.
FERC VSL G1 Violation Severity Level Assignments Should Not Have the Unintended Consequence of Lowering the Current Level of Compliance	The VSL is not changed in TPL-007-2.
FERC VSL G2 Violation Severity Level Assignments Should Ensure Uniformity and Consistency in the Determination of Penalties Guideline 2a: The Single Violation Severity Level Assignment Category for "Binary" Requirements Is Not Consistent Guideline 2b: Violation Severity Level Assignments that Contain Ambiguous Language	The proposed VSL is written to ensure uniformity and consistency in the determination of penalties.  Guideline 2a: The proposed VSL is binary and assigned a Severe VSL.  Guideline 2b: The proposed VSL does not use ambiguous terms, supporting uniformity and consistency in the determination of similar penalties for similar violations.
FERC VSL G3 Violation Severity Level Assignment Should Be	The proposed VSL is worded consistently with the corresponding requirement.

<p>Consistent with the Corresponding Requirement</p>	
<p>FERC VSL G4 Violation Severity Level Assignment Should Be Based on A Single Violation, Not on A Cumulative Number of Violations</p>	<p>The proposed VSL is not based on a cumulative number of violations.</p>



<b>VRF Justifications – TPL-007-2, R2</b>	
<b>Proposed VRF</b>	<b>High</b>
FERC VRF G1 Discussion	Guideline 1- Consistency w/ Blackout Report: N/A
FERC VRF G2 Discussion	Guideline 2- Consistency within a Reliability Standard: The requirement has no sub-requirements so a single VRF was assigned.
FERC VRF G3 Discussion	Guideline 3- Consistency among Reliability Standards. A VRF of High is consistent with the VRF for Reliability Standard TPL-001-4 Requirement R1 as amended in NERC's filing dated August 29, 2014, which requires Transmission Planners and Planning Coordinators to maintain models within its respective planning area for performing studies needed to complete its Planning Assessment. Proposed TPL-007-2, Requirement R2 requires responsible entities to maintain System models and GIC System models of the responsible entity's planning area for performing the studies needed to complete benchmark and supplemental GMD Vulnerability Assessments.
FERC VRF G4 Discussion	Guideline 4- Consistency with NERC Definitions of VRFs. The VRF of High is consistent with the NERC VRF Definition. The System Models and GIC System Models serve as the foundation for all conditions and events that are required to be studied and evaluated in the benchmark and supplemental GMD Vulnerability Assessments. For this reason, failure to maintain models of the responsible entity's planning area for performing GMD studies could, under GMD conditions that are as severe as the benchmark and supplemental GMD event, place the Bulk Electric System at an unacceptable risk of instability, separation, or cascading failures.
FERC VRF G5 Discussion	Guideline 5- Treatment of Requirements that Co-mingle More than One Obligation. This requirement does not co-mingle a higher-risk reliability objective with a lesser- risk reliability objective.

Proposed VSLs – TPL-007-2, R2			
Lower	Moderate	High	Severe
N/A	N/A	The responsible entity did not maintain either System models or GIC System models of the responsible entity’s planning area for performing the study or studies or studies needed to complete benchmark and supplemental GMD Vulnerability Assessments.	The responsible entity did not maintain both System models and GIC System models of the responsible entity’s planning area for performing the study or studies or studies needed to complete benchmark and supplemental GMD Vulnerability Assessments.

VSL Justifications – TPL-007-2, R2	
NERC VSL Guidelines	Consistent with NERC's VSL Guidelines. The requirement may be described by elements or quantities to evaluate degrees of compliance. Two VSLs are specified for a graduated scale.
FERC VSL G1 Violation Severity Level Assignments Should Not Have the Unintended Consequence of Lowering the Current Level of Compliance	The VSL is not changed in TPL-007-2.
FERC VSL G2	The proposed VSL is written to ensure uniformity and consistency in the determination of penalties.

VSL Justifications – TPL-007-2, R2	
<p>Violation Severity Level Assignments Should Ensure Uniformity and Consistency in the Determination of Penalties</p> <p>Guideline 2a: The Single Violation Severity Level Assignment Category for "Binary" Requirements Is Not Consistent</p> <p>Guideline 2b: Violation Severity Level Assignments that Contain Ambiguous Language</p>	<p>Guideline 2a: The proposed VSL is not binary.</p> <p>Guideline 2b: The proposed VSL does not use ambiguous terms, supporting uniformity and consistency in the determination of similar penalties for similar violations.</p>
<p>FERC VSL G3</p> <p>Violation Severity Level Assignment Should Be Consistent with the Corresponding Requirement</p>	<p>The proposed VSL is worded consistently with the corresponding requirement.</p>
<p>FERC VSL G4</p> <p>Violation Severity Level Assignment Should Be Based on A Single Violation, Not on A Cumulative Number of Violations</p>	<p>The proposed VSL is not based on a cumulative number of violations.</p>

<b>VRF Justifications – TPL-007-2, R3</b>	
<b>Proposed VRF</b>	<b>Medium</b>
FERC VRF G1 Discussion	Guideline 1- Consistency w/ Blackout Report: N/A
FERC VRF G2 Discussion	Guideline 2- Consistency within a Reliability Standard: The requirement has no sub-requirements so a single VRF was assigned.
FERC VRF G3 Discussion	Guideline 3- Consistency among Reliability Standards. A VRF of Medium is consistent with Reliability Standard TPL-001-4 Requirement R5 which requires Transmission Planners and Planning Coordinators to have criteria for acceptable System steady state voltage limits. Proposed TPL-007-2 Requirement R4 requires responsible entities to have criteria for acceptable System steady state voltage performance for its System during the benchmark GMD event; these criteria may be different from the voltage limits determined in Reliability Standard TPL-001-4 Requirement R5.
FERC VRF G4 Discussion	Guideline 4- Consistency with NERC Definitions of VRFs. The VRF of Medium is consistent with the NERC VRF Definition. Failure to have criteria for acceptable System steady state voltage limits for its System during a GMD planning event could directly and adversely affect the electrical state or capability of the Bulk Electric System, or the ability to effectively monitor, control, or restore the Bulk Electric System during an actual GMD event. However, it is unlikely that such a failure by itself would lead to Bulk Electric System instability, separation, or cascading.
FERC VRF G5 Discussion	Guideline 5- Treatment of Requirements that Co-mingle More than One Obligation. This requirement does not co-mingle a higher-risk reliability objective with a lesser- risk reliability objective.

<b>Proposed VSLs – TPL-007-2, R3</b>			
<b>Lower</b>	<b>Moderate</b>	<b>High</b>	<b>Severe</b>
N/A	N/A	N/A	The responsible entity did not have criteria for acceptable

Proposed VSLs – TPL-007-2, R3			
			System steady state voltage performance for its System during the GMD events described in Attachment 1 as required.

VSL Justifications – TPL-007-2, R3	
NERC VSL Guidelines	Consistent with NERC's VSL Guidelines. The requirement does not have elements or quantities to evaluate degrees of compliance. A VSL of Severe is assigned for non-compliance.
FERC VSL G1 Violation Severity Level Assignments Should Not Have the Unintended Consequence of Lowering the Current Level of Compliance	The VSL is not changed in TPL-007-2.
FERC VSL G2 Violation Severity Level Assignments Should Ensure Uniformity and Consistency in the Determination of Penalties Guideline 2a: The Single Violation Severity Level Assignment Category for	The proposed VSL is written to ensure uniformity and consistency in the determination of penalties.  Guideline 2a: The proposed VSL is binary and assigned a Severe VSL.

**VSL Justifications – TPL-007-2, R3**

<p>"Binary" Requirements Is Not Consistent Guideline 2b: Violation Severity Level Assignments that Contain Ambiguous Language</p>	<p>Guideline 2b: The proposed VSL does not use ambiguous terms, supporting uniformity and consistency in the determination of similar penalties for similar violations.</p>
<p>FERC VSL G3 Violation Severity Level Assignment Should Be Consistent with the Corresponding Requirement</p>	<p>The proposed VSL is worded consistently with the corresponding requirement.</p>
<p>FERC VSL G4 Violation Severity Level Assignment Should Be Based on A Single Violation, Not on A Cumulative Number of Violations</p>	<p>The proposed VSL is not based on a cumulative number of violations.</p>

<b>VRF Justifications – TPL-007-2, R4</b>	
<b>Proposed VRF</b>	<b>High</b>
FERC VRF G1 Discussion	Guideline 1- Consistency w/ Blackout Report: N/A
FERC VRF G2 Discussion	Guideline 2- Consistency within a Reliability Standard: The requirement has no sub-requirements so a single VRF was assigned.
FERC VRF G3 Discussion	Guideline 3- Consistency among Reliability Standards. A VRF of High is consistent with Reliability Standard TPL-001-4 Requirement R2 which requires Transmission Planners and Planning Coordinators to prepare an annual Planning Assessment to ensure its portion of the Bulk Electric System meets performance criteria. Proposed TPL-007-2 Requirement R4 requires responsible entities to complete a benchmark GMD Vulnerability Assessment to ensure the system meets performance criteria during the benchmark GMD event.
FERC VRF G4 Discussion	Guideline 4- Consistency with NERC Definitions of VRFs. The VRF of High is consistent with the NERC VRF Definition. Failure to complete a benchmark GMD Vulnerability Assessment could, under GMD conditions that are as severe as the benchmark GMD event, place the Bulk Electric System at an unacceptable risk of instability, separation, or cascading failures.
FERC VRF G5 Discussion	Guideline 5- Treatment of Requirements that Co-mingle More than One Obligation. This requirement does not co-mingle a higher-risk reliability objective with a lesser- risk reliability objective.

<b>Proposed VSLs – TPL-007-2, R4</b>			
<b>Lower</b>	<b>Moderate</b>	<b>High</b>	<b>Severe</b>
The responsible entity completed a benchmark GMD Vulnerability Assessment, but it was more than 60 calendar	The responsible entity's completed benchmark GMD Vulnerability Assessment failed to satisfy one of elements listed	The responsible entity's completed benchmark GMD Vulnerability Assessment failed to satisfy two of the elements	The responsible entity's completed benchmark GMD Vulnerability Assessment failed to satisfy three of the elements

Proposed VSLs – TPL-007-2, R4			
months and less than or equal to 64 calendar months since the last benchmark GMD Vulnerability Assessment.	<p>in Requirement R4, Parts 4.1 through 4.3;</p> <p>OR</p> <p>The responsible entity completed a benchmark GMD Vulnerability Assessment, but it was more than 64 calendar months and less than or equal to 68 calendar months since the last benchmark GMD Vulnerability Assessment.</p>	<p>listed in Requirement R4, Parts 4.1 through 4.3;</p> <p>OR</p> <p>The responsible entity completed a benchmark GMD Vulnerability Assessment, but it was more than 68 calendar months and less than or equal to 72 calendar months since the last benchmark GMD Vulnerability Assessment.</p>	<p>listed in Requirement R4, Parts 4.1 through 4.3;</p> <p>OR</p> <p>The responsible entity completed a benchmark GMD Vulnerability Assessment, but it was more than 72 calendar months since the last benchmark GMD Vulnerability Assessment;</p> <p>OR</p> <p>The responsible entity does not have a completed benchmark GMD Vulnerability Assessment.</p>

VSL Justifications – TPL-007-2, R4	
NERC VSL Guidelines	Consistent with NERC's VSL Guidelines. The requirement may be described by elements or quantities to evaluate degrees of compliance. Four VSLs are specified for a graduated scale.
FERC VSL G1 Violation Severity Level Assignments Should Not Have the Unintended Consequence of	The VSL is not changed in TPL-007-2.



VSL Justifications – TPL-007-2, R4	
Lowering the Current Level of Compliance	
<p>FERC VSL G2</p> <p>Violation Severity Level Assignments Should Ensure Uniformity and Consistency in the Determination of Penalties</p> <p>Guideline 2a: The Single Violation Severity Level Assignment Category for "Binary" Requirements Is Not Consistent</p> <p>Guideline 2b: Violation Severity Level Assignments that Contain Ambiguous Language</p>	<p>The proposed VSL is written to ensure uniformity and consistency in the determination of penalties.</p> <p>Guideline 2a: The proposed VSL is not binary.</p> <p>Guideline 2b: The proposed VSL does not use ambiguous terms, supporting uniformity and consistency in the determination of similar penalties for similar violations.</p>
<p>FERC VSL G3</p> <p>Violation Severity Level Assignment Should Be Consistent with the Corresponding Requirement</p>	<p>The proposed VSL is worded consistently with the corresponding requirement.</p>
<p>FERC VSL G4</p> <p>Violation Severity Level Assignment Should Be Based on A Single Violation, Not on A</p>	<p>The proposed VSL is not based on a cumulative number of violations.</p>

**VSL Justifications – TPL-007-2, R4**

Cumulative Number of Violations	
---------------------------------	--

<b>VRF Justifications – TPL-007-2, R5</b>	
<b>Proposed VRF</b>	<b>Medium</b>
FERC VRF G1 Discussion	Guideline 1- Consistency w/ Blackout Report: N/A
FERC VRF G2 Discussion	Guideline 2- Consistency within a Reliability Standard: The requirement has no sub-requirements so a single VRF was assigned.
FERC VRF G3 Discussion	Guideline 3- Consistency among Reliability Standards. A VRF of Medium is consistent with Reliability Standard MOD-032-1 Requirement R2 which requires applicable entities to provide modeling data to Transmission Planners and Planning Coordinators. A VRF of Medium is also consistent with Reliability Standard IRO-010-2 Requirement R3 which requires entities to provide data necessary for the Reliability Coordinator to perform its Operational Planning Analysis and Real-time Assessments. Proposed TPL-007-2 Requirement R5 requires responsible entities to provide specific geomagnetically-induced currents (GIC) flow information to Transmission Owners and Generator Owners for performing transformer thermal impact assessments.
FERC VRF G4 Discussion	Guideline 4- Consistency with NERC Definitions of VRFs. The VRF of Medium is consistent with the NERC VRF Definition. Failure to provide GIC flow information for the benchmark GMD event could directly and adversely affect the electrical state or capability of the Bulk Electric System, or the ability to effectively monitor, control, or restore the Bulk Electric System during a GMD event. However, it is unlikely that such a failure by itself would lead to Bulk Electric System instability, separation, or cascading.
FERC VRF G5 Discussion	Guideline 5- Treatment of Requirements that Co-mingle More than One Obligation. This requirement does not co-mingle a higher-risk reliability objective with a lesser- risk reliability objective.

<b>Proposed VSLs – TPL-007-2, R5</b>			
<b>Lower</b>	<b>Moderate</b>	<b>High</b>	<b>Severe</b>
The responsible entity provided the effective GIC time series, GIC(t), in response to written request, but did so more than 90 calendar days and less than or equal to 100 calendar days after receipt of a written request.	The responsible entity provided the effective GIC time series, GIC(t), in response to written request, but did so more than 100 calendar days and less than or equal to 110 calendar days after receipt of a written request.	The responsible entity provided the effective GIC time series, GIC(t), in response to written request, but did so more than 110 calendar days after receipt of a written request.	The responsible entity did not provide the maximum effective GIC value to the Transmission Owner and Generator Owner that owns each applicable BES power transformer in the planning area; OR The responsible entity did not provide the effective GIC time series, GIC(t), upon written request.

<b>VSL Justifications – TPL-007-2, R5</b>	
NERC VSL Guidelines	Consistent with NERC's VSL Guidelines. The requirement may be described by elements or quantities to evaluate degrees of compliance. Four VSLs are specified for a graduated scale.
FERC VSL G1 Violation Severity Level Assignments Should Not Have the Unintended Consequence of Lowering the Current Level of Compliance	The VLS is not changed in TPL-007-2.

VSL Justifications – TPL-007-2, R5	
<p>FERC VSL G2 Violation Severity Level Assignments Should Ensure Uniformity and Consistency in the Determination of Penalties Guideline 2a: The Single Violation Severity Level Assignment Category for "Binary" Requirements Is Not Consistent Guideline 2b: Violation Severity Level Assignments that Contain Ambiguous Language</p>	<p>The proposed VSL is written to ensure uniformity and consistency in the determination of penalties.</p> <p>Guideline 2a: The proposed VSL is not binary.</p> <p>Guideline 2b: The proposed VSL does not use ambiguous terms, supporting uniformity and consistency in the determination of similar penalties for similar violations.</p>
<p>FERC VSL G3 Violation Severity Level Assignment Should Be Consistent with the Corresponding Requirement</p>	<p>The proposed VSL is worded consistently with the corresponding requirement.</p>
<p>FERC VSL G4 Violation Severity Level Assignment Should Be Based on A Single Violation, Not on A Cumulative Number of Violations</p>	<p>The proposed VSL is not based on a cumulative number of violations.</p>

<b>VRF Justifications – TPL-007-2, R6</b>	
<b>Proposed VRF</b>	<b>Medium</b>
FERC VRF G1 Discussion	Guideline 1- Consistency w/ Blackout Report: N/A
FERC VRF G2 Discussion	Guideline 2- Consistency within a Reliability Standard: The requirement has no sub-requirements so a single VRF was assigned.
FERC VRF G3 Discussion	Guideline 3- Consistency among Reliability Standards. A VRF of Medium is consistent with Reliability Standard FAC-008-3 Requirement R6 which requires Transmission Owners and Generator Owners to have Facility Ratings for all solely and jointly owned Facilities that are consistent with the associated Facility Ratings methodology or documentation. Proposed TPL-007-2 Requirement R6 requires responsible entities to conduct a benchmark thermal impact assessment for solely and jointly owned applicable transformers and provide results including suggested actions to mitigate identified impacts to planning entities.
FERC VRF G4 Discussion	Guideline 4- Consistency with NERC Definitions of VRFs. The VRF of Medium is consistent with the NERC VRF Definition. Failure to conduct a benchmark transformer thermal impact assessment could directly and adversely affect the electrical state or capability of the Bulk Electric System, or the ability to effectively monitor, control, or restore the Bulk Electric System during a GMD event. However, it is unlikely that such a failure by itself would lead to Bulk Electric System instability, separation, or cascading.
FERC VRF G5 Discussion	Guideline 5- Treatment of Requirements that Co-mingle More than One Obligation. This requirement does not co-mingle a higher-risk reliability objective with a lesser- risk reliability objective.

<b>Proposed VSLs – TPL-007-2, R6</b>			
<b>Lower</b>	<b>Moderate</b>	<b>High</b>	<b>Severe</b>
<p>The responsible entity failed to conduct a benchmark thermal impact assessment for 5% or less or one of its solely owned and jointly owned applicable BES power transformers (whichever is greater) where the maximum effective GIC value provided in Requirement R5, Part 5.1, is 75 A or greater per phase;</p> <p>OR</p> <p>The responsible entity conducted a benchmark thermal impact assessment for its solely owned and jointly owned applicable BES power transformers where the maximum effective GIC value provided in Requirement R5, Part 5.1, is 75 A or greater per phase but did so more than 24 calendar months and less than or equal to 26 calendar months</p>	<p>The responsible entity failed to conduct a benchmark thermal impact assessment for more than 5% up to (and including) 10% or two of its solely owned and jointly owned applicable BES power transformers (whichever is greater) where the maximum effective GIC value provided in Requirement R5, Part 5.1, is 75 A or greater per phase;</p> <p>OR</p> <p>The responsible entity conducted a benchmark thermal impact assessment for its solely owned and jointly owned applicable BES power transformers where the maximum effective GIC value provided in Requirement R5, Part 5.1, is 75 A or greater per phase but did so more than 26 calendar months and less than or equal to 28 calendar months</p>	<p>The responsible entity failed to conduct a benchmark thermal impact assessment for more than 10% up to (and including) 15% or three of its solely owned and jointly owned applicable BES power transformers (whichever is greater) where the maximum effective GIC value provided in Requirement R5, Part 5.1, is 75 A or greater per phase;</p> <p>OR</p> <p>The responsible entity conducted a benchmark thermal impact assessment for its solely owned and jointly owned applicable BES power transformers where the maximum effective GIC value provided in Requirement R5, Part 5.1, is 75 A or greater per phase but did so more than 28 calendar months and less than or equal to 30 calendar months</p>	<p>The responsible entity failed to conduct a benchmark thermal impact assessment for more than 15% or more than three of its solely owned and jointly owned applicable BES power transformers (whichever is greater) where the maximum effective GIC value provided in Requirement R5, Part 5.1, is 75 A or greater per phase;</p> <p>OR</p> <p>The responsible entity conducted a benchmark thermal impact assessment for its solely owned and jointly owned applicable BES power transformers where the maximum effective GIC value provided in Requirement R5, Part 5.1, is 75 A or greater per phase but did so more than 30 calendar months of receiving GIC flow information specified in Requirement R5, Part 5.1;</p>

Proposed VSLs – TPL-007-2, R6			
of receiving GIC flow information specified in Requirement R5, Part 5.1.	of receiving GIC flow information specified in Requirement R5, Part 5.1; OR The responsible entity failed to include one of the required elements as listed in Requirement R6, Parts 6.1 through 6.3.	of receiving GIC flow information specified in Requirement R5, Part 5.1; OR The responsible entity failed to include two of the required elements as listed in Requirement R6, Parts 6.1 through 6.3.	OR The responsible entity failed to include three of the required elements as listed in Requirement R6, Parts 6.1 through 6.3.

VSL Justifications – TPL-007-2, R6	
NERC VSL Guidelines	Consistent with NERC's VSL Guidelines. The requirement may be described by elements or quantities to evaluate degrees of compliance. Four VSLs are specified for a graduated scale.
FERC VSL G1 Violation Severity Level Assignments Should Not Have the Unintended Consequence of Lowering the Current Level of Compliance	The VSL is not changed in TPL-007-2.
FERC VSL G2 Violation Severity Level Assignments Should Ensure	The proposed VSL is written to ensure uniformity and consistency in the determination of penalties.



VSL Justifications – TPL-007-2, R6	
<p>Uniformity and Consistency in the Determination of Penalties</p> <p>Guideline 2a: The Single Violation Severity Level Assignment Category for "Binary" Requirements Is Not Consistent</p> <p>Guideline 2b: Violation Severity Level Assignments that Contain Ambiguous Language</p>	<p>Guideline 2a: The proposed VSL is not binary.</p> <p>Guideline 2b: The proposed VSL does not use ambiguous terms, supporting uniformity and consistency in the determination of similar penalties for similar violations.</p>
<p>FERC VSL G3</p> <p>Violation Severity Level Assignment Should Be Consistent with the Corresponding Requirement</p>	<p>The proposed VSL is worded consistently with the corresponding requirement.</p>
<p>FERC VSL G4</p> <p>Violation Severity Level Assignment Should Be Based on A Single Violation, Not on A Cumulative Number of Violations</p>	<p>The proposed VSL is not based on a cumulative number of violations.</p>

<b>VRF Justifications – TPL-007-2, R7</b>	
<b>Proposed VRF</b>	<b>High</b>
FERC VRF G1 Discussion	Guideline 1- Consistency w/ Blackout Report: N/A
FERC VRF G2 Discussion	Guideline 2- Consistency within a Reliability Standard: The requirement has no sub-requirements so a single VRF was assigned.
FERC VRF G3 Discussion	Guideline 3- Consistency among Reliability Standards. A VRF of High is consistent with Reliability Standard TPL-001-4 Requirement R2 which requires Transmission Planners and Planning Coordinators to include a Corrective Action Plan that addresses identified performance issues in the annual Planning Assessment. Proposed TPL-007-2 Requirement R7 requires responsible entities to develop a Corrective Action Plan when results of the benchmark GMD Vulnerability Assessment indicate that the System does not meet performance requirements. While Reliability Standard TPL-001-4 has a single requirement for performing the Planning Assessment and developing the Corrective Action Plan, proposed TPL-007-2 has split the requirements for performing a benchmark GMD Vulnerability Assessment and developing the Corrective Action Plan into two separate requirements because the transformer thermal impact assessments performed by Transmission Owners and Generator Owners must be considered. The sequencing with separate requirements follows a logical flow of the GMD Vulnerability Assessment process.
FERC VRF G4 Discussion	Guideline 4- Consistency with NERC Definitions of VRFs. The VRF of High is consistent with the NERC VRF Definition. Failure to develop a Corrective Action Plan that addresses issues identified in a GMD Vulnerability Assessment could, under GMD conditions that are as severe as the benchmark GMD event, place the Bulk Electric System at an unacceptable risk of instability, separation, or cascading failures.
FERC VRF G5 Discussion	Guideline 5- Treatment of Requirements that Co-mingle More than One Obligation. This requirement does not co-mingle a higher-risk reliability objective with a lesser- risk reliability objective.

<b>Proposed VSLs – TPL-007-2, R7</b>			
<b>Lower</b>	<b>Moderate</b>	<b>High</b>	<b>Severe</b>
The responsible entity's Corrective Action Plan failed to comply with one of the elements in Requirement R7, Parts 7.1 through 7.5.	The responsible entity's Corrective Action Plan failed to comply with two of the elements in Requirement R7, Parts 7.1 through 7.5.	The responsible entity's Corrective Action Plan failed to comply with three of the elements in Requirement R7, Parts 7.1 through 7.5.	The responsible entity's Corrective Action Plan failed to comply with four or more of the elements in Requirement R7, Parts 7.1 through 7.5; OR The responsible entity did not have a Corrective Action Plan as required by Requirement R7.

<b>VSL Justifications – TPL-007-2, R7</b>	
NERC VSL Guidelines	Consistent with NERC's VSL Guidelines. The requirement may be described by elements or quantities to evaluate degrees of compliance. Four VSLs are specified for a graduated scale.
FERC VSL G1 Violation Severity Level Assignments Should Not Have the Unintended Consequence of Lowering the Current Level of Compliance	The proposed requirement is a significant revision to TPL-007-2 to address the directive for Corrective Action Plan deadlines contained in FERC Order No. 830. There is no prior compliance obligation related to the directive. However, the requirement uses the same construct for a graduated scale as TPL-007-1 Requirement R7 and is similar to Reliability Standard TPL-001-4, Requirement R2.
FERC VSL G2 Violation Severity Level Assignments Should Ensure	The proposed VSL is written to ensure uniformity and consistency in the determination of penalties.

VSL Justifications – TPL-007-2, R7

<p>Uniformity and Consistency in the Determination of Penalties</p> <p>Guideline 2a: The Single Violation Severity Level Assignment Category for "Binary" Requirements Is Not Consistent</p> <p>Guideline 2b: Violation Severity Level Assignments that Contain Ambiguous Language</p>	<p>Guideline 2a: The proposed VSL is not binary.</p> <p>Guideline 2b: The proposed VSL does not use ambiguous terms, supporting uniformity and consistency in the determination of similar penalties for similar violations.</p>
<p>FERC VSL G3</p> <p>Violation Severity Level Assignment Should Be Consistent with the Corresponding Requirement</p>	<p>The proposed VSL is worded consistently with the corresponding requirement.</p>
<p>FERC VSL G4</p> <p>Violation Severity Level Assignment Should Be Based on A Single Violation, Not on A Cumulative Number of Violations</p>	<p>The proposed VSL is not based on a cumulative number of violations.</p>

<b>VRF Justifications – TPL-007-2, R8</b>	
<b>Proposed VRF</b>	<b>High</b>
FERC VRF G1 Discussion	Guideline 1- Consistency w/ Blackout Report: N/A
FERC VRF G2 Discussion	Guideline 2- Consistency within a Reliability Standard: The requirement has no sub-requirements so a single VRF was assigned.
FERC VRF G3 Discussion	Guideline 3- Consistency among Reliability Standards. A VRF of High is consistent with Reliability Standard TPL-001-4 Requirement R2 which requires Transmission Planners and Planning Coordinators to prepare an annual Planning Assessment to ensure its portion of the Bulk Electric System meets performance criteria. The proposed requirement is also consistent with approved TPL-007-1 Requirement R4 (unchanged in proposed TPL-007-2 Requirement R4). Proposed TPL-007-2 Requirement R8 requires responsible entities to complete a supplemental GMD Vulnerability Assessment to assess system performance during a supplemental GMD event.
FERC VRF G4 Discussion	Guideline 4- Consistency with NERC Definitions of VRFs. The VRF of High is consistent with the NERC VRF Definition. Failure to complete a supplemental GMD Vulnerability Assessment could, under GMD conditions that are as severe as the supplemental GMD event, place the Bulk Electric System at an unacceptable risk of instability, separation, or cascading failures by precluding responsible entities from considering actions to mitigate risk of Cascading.
FERC VRF G5 Discussion	Guideline 5- Treatment of Requirements that Co-mingle More than One Obligation. This requirement does not co-mingle a higher-risk reliability objective with a lesser- risk reliability objective.

<b>Proposed VSLs – TPL-007-2, R8</b>			
<b>Lower</b>	<b>Moderate</b>	<b>High</b>	<b>Severe</b>
The responsible entity completed a supplemental GMD	The responsible entity's completed supplemental GMD	The responsible entity's completed supplemental GMD	The responsible entity's completed supplemental GMD

Proposed VSLs – TPL-007-2, R8			
<p>Vulnerability Assessment, but it was more than 60 calendar months and less than or equal to 64 calendar months since the last supplemental GMD Vulnerability Assessment;</p> <p>OR</p> <p>The responsible entity's completed supplemental GMD Vulnerability Assessment failed to satisfy one of elements listed in Requirement R8, Parts 8.1 through 8.4;</p>	<p>Vulnerability Assessment failed to satisfy two of elements listed in Requirement R8, Parts 8.1 through 8.4;</p> <p>OR</p> <p>The responsible entity completed a supplemental GMD Vulnerability Assessment, but it was more than 64 calendar months and less than or equal to 68 calendar months since the last supplemental GMD Vulnerability Assessment.</p>	<p>Vulnerability Assessment failed to satisfy three of the elements listed in Requirement R8, Parts 8.1 through 8.4;</p> <p>OR</p> <p>The responsible entity completed a supplemental GMD Vulnerability Assessment, but it was more than 68 calendar months and less than or equal to 72 calendar months since the last supplemental GMD Vulnerability Assessment.</p>	<p>Vulnerability Assessment failed to satisfy four of the elements listed in Requirement R8, Parts 8.1 through 8.4;</p> <p>OR</p> <p>The responsible entity completed a supplemental GMD Vulnerability Assessment, but it was more than 72 calendar months since the last supplemental GMD Vulnerability Assessment;</p> <p>OR</p> <p>The responsible entity does not have a completed supplemental GMD Vulnerability Assessment.</p>

VSL Justifications – TPL-007-2, R8	
NERC VSL Guidelines	Consistent with NERC's VSL Guidelines. The requirement may be described by elements or quantities to evaluate degrees of compliance. Four VSLs are specified for a graduated scale.
FERC VSL G1 Violation Severity Level Assignments Should Not Have the Unintended Consequence of Lowering the Current Level of Compliance	There is no prior compliance obligation related to supplemental GMD Vulnerability Assessment. However, the requirement is similar to approved TPL-007-1, Requirement R4 (unchanged in proposed TPL-007-2 Requirement R4). That requirement also has a graduated scale for VSLs.
FERC VSL G2 Violation Severity Level Assignments Should Ensure Uniformity and Consistency in the Determination of Penalties Guideline 2a: The Single Violation Severity Level Assignment Category for "Binary" Requirements Is Not Consistent Guideline 2b: Violation Severity Level Assignments that Contain Ambiguous Language	The proposed VSL is written to ensure uniformity and consistency in the determination of penalties.  Guideline 2a: The proposed VSL is not binary.  Guideline 2b: The proposed VSL does not use ambiguous terms, supporting uniformity and consistency in the determination of similar penalties for similar violations.
FERC VSL G3 Violation Severity Level Assignment Should Be	The proposed VSL is worded consistently with the corresponding requirement.

## VSL Justifications – TPL-007-2, R8

VSL Justifications – TPL-007-2, R8	
Consistent with the Corresponding Requirement	
FERC VSL G4 Violation Severity Level Assignment Should Be Based on A Single Violation, Not on A Cumulative Number of Violations	The proposed VSL is not based on a cumulative number of violations.



<b>VRF Justifications – TPL-007-2, R9</b>	
<b>Proposed VRF</b>	<b>Medium</b>
FERC VRF G1 Discussion	Guideline 1- Consistency w/ Blackout Report: N/A
FERC VRF G2 Discussion	Guideline 2- Consistency within a Reliability Standard: The requirement has no sub-requirements so a single VRF was assigned.
FERC VRF G3 Discussion	Guideline 3- Consistency among Reliability Standards. A VRF of Medium is consistent with approved TPL-007-1 Requirement R5 (unchanged in proposed TPL-007-2 Requirement R5) which requires responsible entities to provide specific geomagnetically-induced currents (GIC) flow information to Transmission Owners and Generator Owners for performing transformer thermal impact assessments.
FERC VRF G4 Discussion	Guideline 4- Consistency with NERC Definitions of VRFs. The VRF of Medium is consistent with the NERC VRF Definition. Failure to provide GIC flow information for the supplemental GMD event could directly and adversely affect the electrical state or capability of the Bulk Electric System, or the ability to effectively monitor, control, or restore the Bulk Electric System during a GMD event. However, it is unlikely that such a failure by itself would lead to Bulk Electric System instability, separation, or cascading.
FERC VRF G5 Discussion	Guideline 5- Treatment of Requirements that Co-mingle More than One Obligation. This requirement does not co-mingle a higher-risk reliability objective with a lesser- risk reliability objective.

<b>Proposed VSLs – TPL-007-2, R9</b>			
<b>Lower</b>	<b>Moderate</b>	<b>High</b>	<b>Severe</b>
The responsible entity provided the effective GIC time series, GIC(t), in response to written request, but did so more than	The responsible entity provided the effective GIC time series, GIC(t), in response to written request, but did so more than	The responsible entity provided the effective GIC time series, GIC(t), in response to written request, but did so more than	The responsible entity did not provide the maximum effective GIC value to the Transmission Owner and Generator Owner

Proposed VSLs – TPL-007-2, R9			
90 calendar days and less than or equal to 100 calendar days after receipt of a written request.	100 calendar days and less than or equal to 110 calendar days after receipt of a written request.	110 calendar days after receipt of a written request.	that owns each applicable BES power transformer in the planning area; OR The responsible entity did not provide the effective GIC time series, GIC(t), upon written request.

VSL Justifications – TPL-007-2, R9	
NERC VSL Guidelines	Consistent with NERC's VSL Guidelines. The requirement may be described by elements or quantities to evaluate degrees of compliance. Four VSLs are specified for a graduated scale.
FERC VSL G1 Violation Severity Level Assignments Should Not Have the Unintended Consequence of Lowering the Current Level of Compliance	There is no prior compliance obligation related to supplemental GMD Vulnerability Assessment. However, the requirement is similar to approved TPL-007-1, Requirement R5 (unchanged in proposed TPL-007-2 Requirement R5). That requirement also has a graduated scale for VSLs.
FERC VSL G2 Violation Severity Level Assignments Should Ensure	The proposed VSL is written to ensure uniformity and consistency in the determination of penalties.

VSL Justifications – TPL-007-2, R9

<p>Uniformity and Consistency in the Determination of Penalties</p> <p>Guideline 2a: The Single Violation Severity Level Assignment Category for "Binary" Requirements Is Not Consistent</p> <p>Guideline 2b: Violation Severity Level Assignments that Contain Ambiguous Language</p>	<p>Guideline 2a: The proposed VSL is not binary.</p> <p>Guideline 2b: The proposed VSL does not use ambiguous terms, supporting uniformity and consistency in the determination of similar penalties for similar violations.</p>
<p>FERC VSL G3</p> <p>Violation Severity Level Assignment Should Be Consistent with the Corresponding Requirement</p>	<p>The proposed VSL is worded consistently with the corresponding requirement.</p>
<p>FERC VSL G4</p> <p>Violation Severity Level Assignment Should Be Based on A Single Violation, Not on A Cumulative Number of Violations</p>	<p>The proposed VSL is not based on a cumulative number of violations.</p>

<b>VRF Justifications – TPL-007-2, R10</b>	
<b>Proposed VRF</b>	<b>Medium</b>
FERC VRF G1 Discussion	Guideline 1- Consistency w/ Blackout Report: N/A
FERC VRF G2 Discussion	Guideline 2- Consistency within a Reliability Standard: The requirement has no sub-requirements so a single VRF was assigned.
FERC VRF G3 Discussion	Guideline 3- Consistency among Reliability Standards. A VRF of Medium is consistent with approved TPL-007-1 Requirement R6 (unchanged in proposed TPL-007-2 Requirement R6), which requires responsible entities to conduct a benchmark thermal impact assessment for solely and jointly owned applicable transformers and provide results including suggested actions to mitigate identified impacts to planning entities.
FERC VRF G4 Discussion	Guideline 4- Consistency with NERC Definitions of VRFs. The VRF of Medium is consistent with the NERC VRF Definition. Failure to conduct a supplemental transformer thermal impact assessment could directly and adversely affect the electrical state or capability of the Bulk Electric System, or the ability to effectively monitor, control, or restore the Bulk Electric System during a GMD event. However, it is unlikely that such a failure by itself would lead to Bulk Electric System instability, separation, or cascading.
FERC VRF G5 Discussion	Guideline 5- Treatment of Requirements that Co-mingle More than One Obligation. This requirement does not co-mingle a higher-risk reliability objective with a lesser- risk reliability objective.

<b>Proposed VSLs – TPL-007-2, R10</b>			
<b>Lower</b>	<b>Moderate</b>	<b>High</b>	<b>Severe</b>
The responsible entity failed to conduct a supplemental thermal impact assessment for 5% or	The responsible entity failed to conduct a supplemental thermal impact assessment for more	The responsible entity failed to conduct a supplemental thermal impact assessment for more	The responsible entity failed to conduct a supplemental thermal impact assessment for more

Proposed VSLs – TPL-007-2, R10

<p>less or one of its solely owned and jointly owned applicable BES power transformers (whichever is greater) where the maximum effective GIC value provided in Requirement R9, Part 9.1, is 85 A or greater per phase; OR The responsible entity conducted a supplemental thermal impact assessment for its solely owned and jointly owned applicable BES power transformers where the maximum effective GIC value provided in Requirement R9, Part 9.1, is 85 A or greater per phase but did so more than 24 calendar months and less than or equal to 26 calendar months of receiving GIC flow information specified in Requirement R9, Part 9.1.</p>	<p>than 5% up to (and including) 10% or two of its solely owned and jointly owned applicable BES power transformers (whichever is greater) where the maximum effective GIC value provided in Requirement R9, Part 9.1, is 85 A or greater per phase; OR The responsible entity conducted a supplemental thermal impact assessment for its solely owned and jointly owned applicable BES power transformers where the maximum effective GIC value provided in Requirement R9, Part 9.1, is 85 A or greater per phase but did so more than 26 calendar months and less than or equal to 28 calendar months of receiving GIC flow information specified in Requirement R9, Part 9.1; OR</p>	<p>than 10% up to (and including) 15% or three of its solely owned and jointly owned applicable BES power transformers (whichever is greater) where the maximum effective GIC value provided in Requirement R9, Part 9.1, is 85 A or greater per phase; OR The responsible entity conducted a supplemental thermal impact assessment for its solely owned and jointly owned applicable BES power transformers where the maximum effective GIC value provided in Requirement R9, Part 9.1, is 85 A or greater per phase but did so more than 28 calendar months and less than or equal to 30 calendar months of receiving GIC flow information specified in Requirement R9, Part 9.1; OR</p>	<p>than 15% or more than three of its solely owned and jointly owned applicable BES power transformers (whichever is greater) where the maximum effective GIC value provided in Requirement R9, Part 9.1, is 85 A or greater per phase; OR The responsible entity conducted a supplemental thermal impact assessment for its solely owned and jointly owned applicable BES power transformers where the maximum effective GIC value provided in Requirement R9, Part 9.1, is 85 A or greater per phase but did so more than 30 calendar months of receiving GIC flow information specified in Requirement R9, Part 9.1; OR The responsible entity failed to include three of the required elements as listed in</p>
--	--	---	---

Proposed VSLs – TPL-007-2, R10			
	The responsible entity failed to include one of the required elements as listed in Requirement R10, Parts 10.1 through 10.3.	The responsible entity failed to include two of the required elements as listed in Requirement R10, Parts 10.1 through 10.3.	Requirement R10, Parts 10.1 through 10.3.

VSL Justifications – TPL-007-2, R10	
NERC VSL Guidelines	Consistent with NERC's VSL Guidelines. The requirement may be described by elements or quantities to evaluate degrees of compliance. Four VSLs are specified for a graduated scale.
FERC VSL G1 Violation Severity Level Assignments Should Not Have the Unintended Consequence of Lowering the Current Level of Compliance	There is no prior compliance obligation related to supplemental thermal impact assessment. However, the requirement is similar to approved TPL-007-1, Requirement R6 (unchanged in proposed TPL-007-2 Requirement R6). That requirement also has a graduated scale for VSLs.
FERC VSL G2 Violation Severity Level Assignments Should Ensure Uniformity and Consistency in the Determination of Penalties Guideline 2a: The Single Violation Severity Level	The proposed VSL is written to ensure uniformity and consistency in the determination of penalties.  Guideline 2a: The proposed VSL is not binary.

**VSL Justifications – TPL-007-2, R10**

<p>Assignment Category for "Binary" Requirements Is Not Consistent</p> <p>Guideline 2b: Violation Severity Level Assignments that Contain Ambiguous Language</p>	<p>Guideline 2b: The proposed VSL does not use ambiguous terms, supporting uniformity and consistency in the determination of similar penalties for similar violations.</p>
<p>FERC VSL G3</p> <p>Violation Severity Level Assignment Should Be Consistent with the Corresponding Requirement</p>	<p>The proposed VSL is worded consistently with the corresponding requirement.</p>
<p>FERC VSL G4</p> <p>Violation Severity Level Assignment Should Be Based on A Single Violation, Not on A Cumulative Number of Violations</p>	<p>The proposed VSL is not based on a cumulative number of violations.</p>

VRF Justifications – TPL-007-2, R11	
Proposed VRF	Lower
FERC VRF G1 Discussion	Guideline 1- Consistency w/ Blackout Report: N/A
FERC VRF G2 Discussion	Guideline 2- Consistency within a Reliability Standard: The requirement has no sub-requirements so a single VRF was assigned.
FERC VRF G3 Discussion	Guideline 3- Consistency among Reliability Standards. A VRF of Lower is consistent with approved Reliability Standards requiring entities to implement processes to obtain data. These include Reliability Standard MOD-032-1 Requirement R1 and Reliability Standard IRO-010-2 Requirement R1.
FERC VRF G4 Discussion	Guideline 4- Consistency with NERC Definitions of VRFs. The VRF of Lower is consistent with the NERC VRF Definition. Failure to obtain GIC monitor data from at least one GIC monitor located in the system would not be expected to adversely affect the electrical state or capability of the Bulk Electric System, or the ability to effectively monitor, control, or restore the Bulk Electric System.
FERC VRF G5 Discussion	Guideline 5- Treatment of Requirements that Co-mingle More than One Obligation. This requirement does not co-mingle a higher-risk reliability objective with a lesser- risk reliability objective.

Proposed VSLs – TPL-007-2, R11			
Lower	Moderate	High	Severe
N/A	N/A	N/A	The responsible entity did not implement a process to obtain GIC monitor data from at least one GIC monitor located in the Planning Coordinator’s planning area or other part of the system included in the Planning



Proposed VSLs – TPL-007-2, R11			
			Coordinator’s GIC System Model.

VSL Justifications – TPL-007-2, R11	
NERC VSL Guidelines	Consistent with NERC's VSL Guidelines. The requirement does not have elements or quantities to evaluate degrees of compliance. A VSL of Severe is assigned for non-compliance.
FERC VSL G1 Violation Severity Level Assignments Should Not Have the Unintended Consequence of Lowering the Current Level of Compliance	There is no prior compliance obligation for this requirement.
FERC VSL G2 Violation Severity Level Assignments Should Ensure Uniformity and Consistency in the Determination of Penalties Guideline 2a: The Single Violation Severity Level Assignment Category for "Binary" Requirements Is Not Consistent	The proposed VSL is written to ensure uniformity and consistency in the determination of penalties.  Guideline 2a: The proposed VSL is binary and assigned a Severe VSL.

VSL Justifications – TPL-007-2, R11	
Guideline 2b: Violation Severity Level Assignments that Contain Ambiguous Language	Guideline 2b: The proposed VSL does not use ambiguous terms, supporting uniformity and consistency in the determination of similar penalties for similar violations.
FERC VSL G3 Violation Severity Level Assignment Should Be Consistent with the Corresponding Requirement	The proposed VSL is worded consistently with the corresponding requirement.
FERC VSL G4 Violation Severity Level Assignment Should Be Based on A Single Violation, Not on A Cumulative Number of Violations	The proposed VSL is not based on a cumulative number of violations.

<b>VRF Justifications – TPL-007-2, R12</b>	
<b>Proposed VRF</b>	<b>Lower</b>
FERC VRF G1 Discussion	Guideline 1- Consistency w/ Blackout Report: N/A
FERC VRF G2 Discussion	Guideline 2- Consistency within a Reliability Standard: The requirement has no sub-requirements so a single VRF was assigned.
FERC VRF G3 Discussion	Guideline 3- Consistency among Reliability Standards. A VRF of Lower is consistent with approved Reliability Standards requiring entities to implement processes to obtain data. These include Reliability Standard MOD-032-1 Requirement R1 and Reliability Standard IRO-010-2 Requirement R1.
FERC VRF G4 Discussion	Guideline 4- Consistency with NERC Definitions of VRFs. The VRF of Lower is consistent with the NERC VRF Definition. Failure to obtain geomagnetic field data for the planning area would not be expected to adversely affect the electrical state or capability of the Bulk Electric System, or the ability to effectively monitor, control, or restore the Bulk Electric System.
FERC VRF G5 Discussion	Guideline 5- Treatment of Requirements that Co-mingle More than One Obligation. This requirement does not co-mingle a higher-risk reliability objective with a lesser- risk reliability objective.

<b>Proposed VSLs – TPL-007-2, R12</b>			
<b>Lower</b>	<b>Moderate</b>	<b>High</b>	<b>Severe</b>
N/A	N/A	N/A	The responsible entity did not implement a process to obtain geomagnetic field data for its Planning Coordinator’s planning area.

VSL Justifications – TPL-007-2, R12	
NERC VSL Guidelines	Consistent with NERC's VSL Guidelines. The requirement does not have elements or quantities to evaluate degrees of compliance. A VSL of Severe is assigned for non-compliance.
FERC VSL G1 Violation Severity Level Assignments Should Not Have the Unintended Consequence of Lowering the Current Level of Compliance	There is no prior compliance obligation for this requirement.
FERC VSL G2 Violation Severity Level Assignments Should Ensure Uniformity and Consistency in the Determination of Penalties Guideline 2a: The Single Violation Severity Level Assignment Category for "Binary" Requirements Is Not Consistent Guideline 2b: Violation Severity Level Assignments that Contain Ambiguous Language	The proposed VSL is written to ensure uniformity and consistency in the determination of penalties.  Guideline 2a: The proposed VSL is binary and assigned a Severe VSL.  Guideline 2b: The proposed VSL does not use ambiguous terms, supporting uniformity and consistency in the determination of similar penalties for similar violations.
FERC VSL G3 Violation Severity Level Assignment Should Be	The proposed VSL is worded consistently with the corresponding requirement.

## VSL Justifications – TPL-007-2, R12

VSL Justifications – TPL-007-2, R12	
Consistent with the Corresponding Requirement	
FERC VSL G4 Violation Severity Level Assignment Should Be Based on A Single Violation, Not on A Cumulative Number of Violations	The proposed VSL is not based on a cumulative number of violations.

Consideration of Directives

*Reliability Standard for Transmission System Planned Performance for Geomagnetic Disturbance Events*

[Order No. 830](#), 156 FERC ¶ 61,215 (Sep. 22, 2016)

approving Reliability Standard TPL-007-1

#	P	Directive/Guidance	Resolution
1)	PP 44 47-49	<p><b>MODIFY THE BENCHMARK GMD EVENT re SPATIAL AVERAGING</b></p> <p>P44: “[T]he Commission, as proposed in the NOPR, directs NERC to develop revisions to the benchmark GMD event definition so that the reference peak geoelectric field amplitude component is not based solely on spatially-averaged data.”</p> <p>P47: “Without prejudging how NERC proposes to address the Commission’s directive, NERC’s response to this directive should satisfy the NOPR’s concern that reliance on spatially-averaged data alone does not address localized peaks that could potentially affect the reliable operation of the Bulk-Power System.”</p> <p>P48: “NERC could revise [the standard] to apply a higher reference peak geoelectric field amplitude value to assess the impact of localized hot spots on the Bulk-Power System, as suggested by the Trade Associations.”</p> <p>P49: “Consistent with Order No. 779, the Commission does not specify a particular reference peak geoelectric field amplitude value that should be applied to hot spots given present uncertainties.”</p>	<p>The directive is addressed in proposed TPL-007-2 through Requirements for applicable entities to perform supplemental GMD Vulnerability Assessments based on the supplemental GMD event. The supplemental GMD event is a defined event for assessing system performance that is not based on spatially-averaged data.</p> <p>The supplemental GMD event is described in the standard drafting team's (SDT) white paper available on the project page:</p> <p><a href="http://www.nerc.com/pa/Stand/Pages/Project-2013-03-Geomagnetic-Disturbance-Mitigation.aspx">http://www.nerc.com/pa/Stand/Pages/Project-2013-03-Geomagnetic-Disturbance-Mitigation.aspx</a></p>
2)	P65	<p><b>REVISE R6 RE SPATIAL AVERAGING</b></p> <p>P65: “Consistent with our determination above regarding the reference peak geoelectric field amplitude value, the Commission directs NERC to revise Requirement R6 to require registered entities</p>	<p>The directive is addressed in proposed TPL-007-2 Requirements R9 and R10. Applicable entities use geomagnetically-induced current (GIC) information for the supplemental GMD event to perform supplemental thermal impact assessments of applicable power</p>

#	P	Directive/Guidance	Resolution
		<p>to apply spatially averaged and non-spatially averaged peak geoelectric field values, or some equally efficient and effective alternative, when conducting thermal impact assessments.”</p>	<p>transformers.</p> <p>Requirement R9 obligates responsible Planning Coordinators and Transmission Planners to provide GIC flow information to Transmission Owners and Generator Owners for performing supplemental thermal impact assessments. The GIC flow information is based on the supplemental GMD event.</p> <p>Requirement R10 obligates Transmission Owners and Generator Owners to perform supplemental thermal impact assessments on applicable power transformers and provide results to responsible Planning Coordinators and Transmission Planners.</p>
3)	<p><b>PP 88</b> 90, 91, 92</p>	<p><b>REVISE STANDARD TO REQUIRE COLLECTION OF GMD DATA</b></p> <p>P 88: “The Commission ... adopts the NOPR proposal in relevant part and directs NERC to develop revisions to Reliability Standard TPL-007-1 to require responsible entities to collect GIC monitoring and magnetometer data as necessary to enable model validation and situational awareness, including from any devices that must be added to meet this need.</p> <p>The NERC standard drafting team should address the criteria for collecting GIC monitoring and magnetometer data discussed below and provide registered entities with sufficient guidance in terms of defining the data that must be collected, and NERC should propose in the GMD research work plan how it will determine and report on the degree to which industry is following that guidance.”</p> <p><i>GIC Requirements</i></p> <p>P 91: “Each responsible entity that is a transmission owner should be</p>	<p>The directive is addressed in proposed TPL-007-2 Requirements R11 and R12.</p> <p>Requirement R11 obligates responsible Planning Coordinators and Transmission Planners to implement a process to obtain GIC monitor data from at least one GIC monitor located in the Planning Coordinator's planning area or other part of the system included in the Planning Coordinator's GIC System model. The SDT described GIC data collection criteria in the guidance section to promote consistency in achieving the reliability objective and provide responsible entities with flexibility to tailor procedures to their planning area. The guidance addresses the following considerations: monitor locations, monitor specifications, sampling interval, collection periods, data format, and data retention.</p>



#	P	Directive/Guidance	Resolution
		<p>required to collect necessary GIC monitoring data. However, a transmission owner should be able to apply for an exemption from the GIC monitoring data collection requirement if it demonstrates that little or no value would be added to planning and operations.</p> <p>In developing a requirement regarding the collection of GIC monitoring data, NERC should consider the following criteria discussed at the March 1, 2016 Technical Conference: (1) the GIC data is from areas found to have high GIC based on system studies; (2) the GIC data comes from sensitive installations and key parts of the transmission grid; and (3) the data comes from GIC monitors that are not situated near transportation systems using direct current (e.g., subways or light rail.”</p> <p><i>Magnetometer Requirements</i></p> <p>P90: “In developing a requirement regarding the collection of magnetometer data, NERC should consider the following criteria discussed at the March 1, 2016 Technical Conference: (1) the data is sampled at a cadence of at least 10-seconds or faster; (2) the data comes from magnetometers that are physically close to GIC monitors; (3) the data comes from magnetometers that are not near sources of magnetic interference (e.g., roads and local distribution networks); and (4) data is collected from magnetometers spread across wide latitudes and longitudes and from diverse physiographic regions.”</p> <p style="text-align: center;">***</p> <p>P 91: GIC monitoring and magnetometer locations should also be revisited after GIC system models are run with improved ground conductivity models. NERC may also propose to incorporate the GIC monitoring and magnetometer data collection requirements in a different Reliability Standard (e.g., real-time reliability monitoring and analysis capabilities as part of the TOP Reliability Standards).</p>	<p>Requirement R12 obligates responsible Planning Coordinators and Transmission Planners to implement a process to obtain geomagnetic field data for its Planning Coordinator’s planning area. Sources of geomagnetic field data include government observatories, installed equipment owned or operated by the entity, and third-party sources. Entities are referred to INTRAMAGNET guidance for criteria and considerations including data sampling rate (10-s or faster) and data format. By requiring responsible Planning Coordinators and Transmission Planners to obtain geomagnetic field data for their planning areas, the requirement ensures data is obtained from diverse geographic areas (latitudes and longitudes) of the North American Bulk-Power System.</p>

#	P	Directive/Guidance	Resolution
		<p>P 92: “[T]he Commission determines that requiring responsible entities to collect necessary GIC monitoring and magnetometer data, rather than install GIC monitors and magnetometers, affords greater flexibility while obtaining significant benefits.”</p>	
4)	P 101, 102	<p><b>REVISE TPL-007 TO REQUIRE DEADLINES FOR THE DEVELOPMENT AND COMPLETION OF CORRECTIVE ACTION PLANS</b></p> <p>P 101: “The Commission directs NERC to modify Reliability Standard TPL-007-1 to include a deadline of one year from the completion of the GMD Vulnerability Assessments to complete the development of corrective action plans.”</p> <p>P 102: “The Commission also directs NERC to modify Reliability Standard TPL-007-1 to include a two-year deadline after the development of the corrective action plan to complete the implementation of non-hardware mitigation and four-year deadline to complete hardware mitigation...”</p>	<p>The directive is addressed in proposed TPL-007-2 Requirement R7.</p> <p>Part 7.2 specifies that responsible entities must develop Corrective Action Plans (CAP) within one year of completing the benchmark GMD Vulnerability Assessment.</p> <p>Part 7.3 requires responsible entities to include a timetable in the CAP that must specify:</p> <ul style="list-style-type: none"> <li>• Implementation of non-hardware mitigation within two years of the development of the CAP; and</li> <li>• Implementation of hardware mitigation within four years of the development of the CAP.</li> </ul> <p>Part 7.4 provides responsible entities with flexibility to revise the CAP and timetables if situations beyond the control of the responsible entity prevent implementation of the CAP within the specified timetable. The provision is necessary to account for potential planning, siting, budgeting approval, or regulatory uncertainties associated with transmission system projects that are not within the responsible entity’s control. Responsible entities are obligated to document the revised CAP and update the revised CAP every 12 calendar months until implemented.</p>

#	P	Directive/Guidance	Resolution
			<p>Requirement R8 requires responsible entities to complete a supplemental GMD Vulnerability Assessment, based on the supplemental GMD event, to evaluate localized enhancements of geomagnetic field during a severe GMD event that could potentially affect the reliable operation of the Bulk-Power System. Localized enhancements of geomagnetic field can result in geoelectric field values above the spatially-averaged benchmark in a local area. Part 8.3 specifies that if the responsible entity concludes that there is Cascading caused by the supplemental GMD event, then the responsible entity shall conduct an analysis of possible actions to reduce the likelihood or mitigate the impacts and the event.</p> <p>Proposed TPL-007-2 does not require responsible entities to implement a Corrective Action Plan to address impacts identified in the supplemental GMD Vulnerability Assessment because mandatory mitigation on the basis of the supplemental GMD Vulnerability Assessment may not provide effective reliability benefit or use industry resources optimally. As discussed in the Supplemental GMD Event Description white paper, the supplemental GMD event is based on a small number of observed localized enhancement events that provide only general insight into the geographic size of localized events during severe solar storms. Additionally, the state-of-the-art modeling tools do not provide entities with capabilities to realistically model localized enhancements within a severe GMD event, and as a result entities may need to employ conservative approaches in the GMD Vulnerability Assessment such as applying the localized peak geoelectric field over an</p>

#	P	Directive/Guidance	Resolution
			<p>entire planning area.</p> <p>The approach taken in TPL-007-2 to mitigating impacts identified in the supplemental GMD Vulnerability Assessment provides responsible entities with flexibility to consider and select actions based on entity-specific factors. This is similar to the approach taken in Reliability Standard TPL-001-4 for extreme events (TPL-001-4 Requirement R3 Part 3.5).</p>

# Standards Announcement

## Project 2013-03 Geomagnetic Disturbance Mitigation TPL-007-2

**Reminder:** Initial Ballot and Non-binding Poll Open through August 11, 2017

### [Now Available](#)

An initial ballot for **TPL-007-2 - Transmission System Planned Performance for Geomagnetic Disturbance Events** and non-binding poll of the associated Violation Risk Factors and Violation Severity Levels are open through **8 p.m. Eastern, Friday, August 11, 2017**.

### Balloting

Members of the ballot pools associated with this project can log in and submit their vote for the standard and non-binding poll by clicking [here](#). If you experience any difficulties in using the Standards Balloting and Commenting System (SBS), contact [Nasheema Santos](#).

*If you are having difficulty accessing the SBS due to a forgotten password, incorrect credential error messages, or system lock-out, contact NERC IT support directly at <https://support.nerc.net/> (Monday – Friday, 8 a.m. – 5 p.m. Eastern).*

- *Passwords expire every **6 months** and must be reset.*
- *The SBS **is not** supported for use on mobile devices.*
- *Please be mindful of ballot and comment period closing dates. We ask to **allow at least 48 hours** for NERC support staff to assist with inquiries. Therefore, it is recommended that users try logging into their SBS accounts **prior to the last day** of a comment/ballot period.*

### Next Steps

The ballot results will be announced and posted on the project page. The drafting team will review all responses received during the comment period and determine the next steps of the project.

For more information on the Standards Development Process, refer to the [Standard Processes Manual](#).

For more information or assistance, contact Senior Standards Developer, [Scott Barfield-McGinnis](#) (via email or at (404) 446-9689).

North American Electric Reliability Corporation  
3353 Peachtree Rd, NE  
Suite 600, North Tower  
Atlanta, GA 30326  
404-446-2560 | [www.nerc.com](http://www.nerc.com)

# Standards Announcement

## Project 2013-03 Geomagnetic Disturbance Mitigation TPL-007-2

Formal Comment Period Open through August 11, 2017  
Ballot Pools Forming through July 27, 2017

### [Now Available](#)

A 45-day formal comment period for **TPL-007-2 - Transmission System Planned Performance for Geomagnetic Disturbance Events**, is open through **8 p.m. Eastern, Friday, August 11, 2017**.

### Commenting

Use the [electronic form](#) to submit comments on the standard. If you experience any difficulties in using the electronic form, contact [Nasheema Santos](#). An unofficial Word version of the comment form is posted on the [project page](#).

### Join the Ballot Pools

Ballot pools are being formed through **8 p.m. Eastern, Thursday, July 27, 2017**. Registered Ballot Body members may join the ballot pools [here](#).

*If you are having difficulty accessing the SBS due to a forgotten password, incorrect credential error messages, or system lock-out, contact NERC IT support directly at <https://support.nerc.net/> (Monday – Friday, 8 a.m. - 5 p.m. Eastern).*

- *Passwords expire every **6 months** and must be reset.*
- *The SBS **is not** supported for use on mobile devices.*
- *Please be mindful of ballot and comment period closing dates. We ask to **allow at least 48 hours** for NERC support staff to assist with inquiries. Therefore, it is recommended that users try logging into their SBS accounts **prior to the last day** of a comment/ballot period.*

### Next Steps

Initial ballots for the standard and non-binding poll of the associated Violation Risk Factors and Violation Severity Levels will be conducted **August 2-11, 2017**.

For more information on the Standards Development Process, refer to the [Standard Processes Manual](#).

For more information or assistance, contact Senior Standards Developer, [Mark Olson](#) (via email) or at (404) 446-9760.

North American Electric Reliability Corporation  
3353 Peachtree Rd, NE  
Suite 600, North Tower  
Atlanta, GA 30326  
404-446-2560 | [www.nerc.com](http://www.nerc.com)

## BALLOT RESULTS

Comment: View Comment Results (/CommentResults/Index/95)

**Ballot Name:** 2013-03 Geomagnetic Disturbance Mitigation TPL-007-2 IN 1 ST

**Voting Start Date:** 8/2/2017 12:01:00 AM

**Voting End Date:** 8/11/2017 8:00:00 PM

**Ballot Type:** ST

**Ballot Activity:** IN

**Ballot Series:** 1

**Total # Votes:** 242

**Total Ballot Pool:** 303

**Quorum:** 79.87

**Weighted Segment Value:** 72.67

Segment	Ballot Pool	Segment Weight	Affirmative Votes	Affirmative Fraction	Negative Votes w/ Comment	Negative Fraction w/ Comment	Negative Votes w/o Comment	Abstain	No Vote
Segment: 1	76	1	39	0.684	18	0.316	0	8	11
Segment: 2	7	0.4	3	0.3	1	0.1	0	0	3
Segment: 3	71	1	37	0.698	16	0.302	0	5	13
Segment: 4	16	1	7	0.636	4	0.364	0	2	3
Segment: 5	70	1	31	0.674	15	0.326	0	7	17
Segment: 6	50	1	24	0.686	11	0.314	0	4	11
Segment: 7	1	0	0	0	0	0	0	0	1
Segment: 8	3	0.2	2	0.2	0	0	0	0	1
Segment: 1	1	0.1	1	0.1	0	0	0	0	0



Segment	Ballot Pool	Segment Weight	Affirmative Votes	Affirmative Fraction	Negative Votes w/ Comment	Negative Fraction w/ Comment	Negative Votes w/o Comment	Abstain	No Vote
Segment: 10	8	0.6	6	0.6	0	0	0	1	1
Totals:	303	6.3	150	4.578	65	1.722	0	27	61

## BALLOT POOL MEMBERS

Show  entries

Search:

Segment	Organization	Voter	Designated Proxy	Ballot	NERC Memo
1	AEP - AEP Service Corporation	Dennis Sauriol		Negative	Comments Submitted
1	Allete - Minnesota Power, Inc.	Jamie Monette		Abstain	N/A
1	Ameren - Ameren Services	Eric Scott		None	N/A
1	American Transmission Company, LLC	Lauren Price		Affirmative	N/A
1	APS - Arizona Public Service Co.	Michelle Amarantos		Negative	Comments Submitted
1	Associated Electric Cooperative, Inc.	Mark Riley		Affirmative	N/A
1	Balancing Authority of Northern California	Kevin Smith	Joe Tarantino	Affirmative	N/A
1	BC Hydro and Power Authority	Patricia Robertson		Abstain	N/A
1	Berkshire Hathaway Energy - MidAmerican Energy Co.	Terry Harbour		Negative	Comments Submitted

Segment	Organization	Voter	Designated Proxy	Ballot	NERC Memo
1	Bonneville Power Administration	Kammy Rogers-Holliday		Affirmative	N/A
1	Brazos Electric Power Cooperative, Inc.	Tony Kroskey		Negative	Third-Party Comments
1	CenterPoint Energy Houston Electric, LLC	John Brockhan		Negative	Comments Submitted
1	Central Hudson Gas & Electric Corp.	Frank Pace		Affirmative	N/A
1	City Utilities of Springfield, Missouri	Michael Buyce		None	N/A
1	Cleco Corporation	John Lindsey	Louis Guidry	Affirmative	N/A
1	Con Ed - Consolidated Edison Co. of New York	Daniel Grinkevich		Affirmative	N/A
1	CPS Energy	Gladys DeLaO		None	N/A
1	Duke Energy	Doug Hils		Affirmative	N/A
1	Entergy - Entergy Services, Inc.	Oliver Burke		Affirmative	N/A
1	Eversource Energy	Quintin Lee		Affirmative	N/A
1	Exelon	Chris Scanlon		Negative	Comments Submitted
1	FirstEnergy - FirstEnergy Corporation	Karen Yoder		Affirmative	N/A
1	Georgia Transmission Corporation	Jason Snodgrass	Greg Davis	Affirmative	N/A
1	Great Plains Energy - Kansas City Power and Light Co.	James McBee	Douglas Webb	Affirmative	N/A
1	Great River Energy	Gordon Pietsch		Affirmative	N/A
1	Hydro One Networks, Inc.	Payam Farahbakhsh		Negative	Comments Submitted
1	Hydro-Québec TransÉnergie	Nicolas Turcotte		Negative	Comments Submitted

<b>Segment</b>	<b>Organization</b>	<b>Voter</b>	<b>Designated Proxy</b>	<b>Ballot</b>	<b>NERC Memo</b>
1	IDACORP - Idaho Power Company	Laura Nelson		Affirmative	N/A
1	Imperial Irrigation District	Jesus Sammy Alcaraz		None	N/A
1	International Transmission Company Holdings Corporation	Michael Moltane	Stephanie Burns	None	N/A
1	KAMO Electric Cooperative	Walter Kenyon		None	N/A
1	Lakeland Electric	Larry Watt		None	N/A
1	Lincoln Electric System	Danny Pudenz		Affirmative	N/A
1	Long Island Power Authority	Robert Ganley		Affirmative	N/A
1	Los Angeles Department of Water and Power	faranak sarbaz		Abstain	N/A
1	M and A Electric Power Cooperative	William Price		Affirmative	N/A
1	Manitoba Hydro	Mike Smith		Negative	Comments Submitted
1	MEAG Power	David Weekley	Scott Miller	Abstain	N/A
1	Minnkota Power Cooperative Inc.	Theresa Allard		Abstain	N/A
1	Muscatine Power and Water	Andy Kurriger		Affirmative	N/A
1	N.W. Electric Power Cooperative, Inc.	Mark Ramsey		Affirmative	N/A
1	National Grid USA	Michael Jones		Affirmative	N/A
1	Nebraska Public Power District	Jamison Cawley		Abstain	N/A
1	New York Power Authority	Salvatore Spagnolo		Affirmative	N/A
1	NextEra Energy - Florida Power and Light Co.	Mike ONeil		Affirmative	N/A

Segment	Organization	Voter	Designated Proxy	Ballot	NERC Memo
1	NiSource - Northern Indiana Public Service Co.	Steve Toosevich		Negative	Comments Submitted
1	Northeast Missouri Electric Power Cooperative	Kevin White		Affirmative	N/A
1	NorthWestern Energy	Belinda Tierney		None	N/A
1	OGE Energy - Oklahoma Gas and Electric Co.	Terri Pyle		Affirmative	N/A
1	Omaha Public Power District	Doug Peterchuck		Negative	Comments Submitted
1	Oncor Electric Delivery	Lee Maurer	Eric Shaw	Affirmative	N/A
1	Peak Reliability	Scott Downey		Affirmative	N/A
1	Platte River Power Authority	Matt Thompson		Affirmative	N/A
1	PNM Resources - Public Service Company of New Mexico	Laurie Williams		Negative	Comments Submitted
1	Portland General Electric Co.	Scott Smith		None	N/A
1	PPL Electric Utilities Corporation	Brenda Truhe		Affirmative	N/A
1	PSEG - Public Service Electric and Gas Co.	Joseph Smith		Affirmative	N/A
1	Public Utility District No. 1 of Snohomish County	Long Duong		Abstain	N/A
1	Sacramento Municipal Utility District	Arthur Starkovich	Joe Tarantino	Affirmative	N/A
1	Salt River Project	Steven Cobb		Negative	Comments Submitted
1	Santee Cooper	Shawn Abrams		Negative	Comments Submitted
1	SCANA - South Carolina Electric and Gas Co.	Tom Hanzlik		Affirmative	N/A
1	Seattle City Light	Pawel Krupa		None	N/A

Segment	Organization	Voter	Designated Proxy	Ballot	NERC Memo
1	Seminole Electric Cooperative, Inc.	Mark Churilla	Bret Galbraith	Negative	Comments Submitted
1	Sempra - San Diego Gas and Electric	Martine Blair		Affirmative	N/A
1	Sho-Me Power Electric Cooperative	Peter Dawson		Affirmative	N/A
1	Southern Company - Southern Company Services, Inc.	Katherine Prewitt		Negative	Comments Submitted
1	Sunflower Electric Power Corporation	Paul Mehlhaff		Negative	Third-Party Comments
1	Tacoma Public Utilities (Tacoma, WA)	John Merrell		Affirmative	N/A
1	Tallahassee Electric (City of Tallahassee, FL)	Scott Langston		Abstain	N/A
1	Tennessee Valley Authority	Howell Scott		Affirmative	N/A
1	Tri-State G and T Association, Inc.	Tracy Sliman		Negative	Comments Submitted
1	VELCO -Vermont Electric Power Company, Inc.	Randy Buswell		None	N/A
1	Westar Energy	Kevin Giles		Affirmative	N/A
1	Western Area Power Administration	sean erickson		Affirmative	N/A
1	Xcel Energy, Inc.	Dean Schiro		Affirmative	N/A
2	California ISO	Richard Vine		None	N/A
2	Electric Reliability Council of Texas, Inc.	Brandon Gleason		None	N/A
2	ISO New England, Inc.	Michael Puscas	Joshua Eason	Negative	Comments Submitted
2	Midcontinent ISO, Inc.	Ellen Oswald		None	N/A
2	New York Independent System Operator	Gregory Campoli		Affirmative	N/A
2	PJM Interconnection, L.L.C.	Mark Holman		Affirmative	N/A

<b>Segment</b>	<b>Organization</b>	<b>Voter</b>	<b>Designated Proxy</b>	<b>Ballot</b>	<b>NERC Memo</b>
2	Southwest Power Pool, Inc. (RTO)	Charles Yeung		Affirmative	N/A
3	AEP	Aaron Austin		Negative	Comments Submitted
3	AES - Indianapolis Power and Light Co.	Bette White		None	N/A
3	Ameren - Ameren Services	David Jendras		None	N/A
3	APS - Arizona Public Service Co.	Vivian Vo		Negative	Comments Submitted
3	Austin Energy	W. Dwayne Preston		Affirmative	N/A
3	Avista - Avista Corporation	Scott Kinney		None	N/A
3	Basin Electric Power Cooperative	Jeremy Voll		Affirmative	N/A
3	BC Hydro and Power Authority	Hootan Jarollahi		Abstain	N/A
3	Berkshire Hathaway Energy - MidAmerican Energy Co.	Annette Johnston	Darnez Gresham	Negative	Comments Submitted
3	Black Hills Corporation	Eric Egge	Maryanne Darling-Reich	None	N/A
3	Bonneville Power Administration	Rebecca Berdahl		Affirmative	N/A
3	Central Electric Power Cooperative (Missouri)	Adam Weber		Affirmative	N/A
3	City of Vero Beach	Ginny Beigel	Brandon McCormick	Negative	Comments Submitted
3	Clark Public Utilities	Jack Stamper		None	N/A
3	Cleco Corporation	Michelle Corley	Louis Guidry	Affirmative	N/A
3	CMS Energy - Consumers Energy Company	Karl Blaszkowski		Affirmative	N/A
3	Colorado Springs Utilities	Hillary Dobson		None	N/A

<b>Segment</b>	<b>Organization</b>	<b>Voter</b>	<b>Designated Proxy</b>	<b>Ballot</b>	<b>NERC Memo</b>
3	Con Ed - Consolidated Edison Co. of New York	Peter Yost		Affirmative	N/A
3	Cowlitz County PUD	Russell Noble		Affirmative	N/A
3	Dominion - Dominion Resources, Inc.	Connie Lowe		Affirmative	N/A
3	DTE Energy - Detroit Edison Company	Karie Barczak		Affirmative	N/A
3	Duke Energy	Lee Schuster		Affirmative	N/A
3	Edison International - Southern California Edison Company	Romel Aquino		Affirmative	N/A
3	Eversource Energy	Mark Kenny		None	N/A
3	Exelon	John Bee		Negative	Comments Submitted
3	FirstEnergy - FirstEnergy Corporation	Aaron Ghodooshim		Affirmative	N/A
3	Florida Municipal Power Agency	Joe McKinney	Brandon McCormick	Negative	Comments Submitted
3	Gainesville Regional Utilities	Ken Simmons		Negative	Third-Party Comments
3	Georgia System Operations Corporation	Scott McGough		Affirmative	N/A
3	Great Plains Energy - Kansas City Power and Light Co.	Jessica Tucker	Douglas Webb	Affirmative	N/A
3	Great River Energy	Brian Glover		Affirmative	N/A
3	Hydro One Networks, Inc.	Paul Malozewski		Negative	Third-Party Comments
3	Lakeland Electric	David Hadzima		None	N/A
3	Lincoln Electric System	Jason Fortik		Affirmative	N/A
3	M and A Electric Power Cooperative	Stephen Pogue		Affirmative	N/A

Segment	Organization	Voter	Designated Proxy	Ballot	NERC Memo
3	Manitoba Hydro	Karim Abdel-Hadi		Negative	Comments Submitted
3	MEAG Power	Roger Brand	Scott Miller	Abstain	N/A
3	Modesto Irrigation District	Jack Savage	Nick Braden	Affirmative	N/A
3	Muscatine Power and Water	Seth Shoemaker		Affirmative	N/A
3	National Grid USA	Brian Shanahan		Affirmative	N/A
3	Nebraska Public Power District	Tony Eddleman		Abstain	N/A
3	New York Power Authority	David Rivera	Shelly Dineen	Affirmative	N/A
3	NiSource - Northern Indiana Public Service Co.	Aimee Harris		Negative	Comments Submitted
3	NW Electric Power Cooperative, Inc.	John Stickley		Affirmative	N/A
3	Ocala Utility Services	Randy Hahn		Negative	Third-Party Comments
3	OGE Energy - Oklahoma Gas and Electric Co.	Donald Hargrove		Affirmative	N/A
3	Omaha Public Power District	Aaron Smith		Negative	Comments Submitted
3	Owensboro Municipal Utilities	Thomas Lyons		Affirmative	N/A
3	Platte River Power Authority	Jeff Landis		Affirmative	N/A
3	PNM Resources - Public Service Company of New Mexico	Lynn Goldstein		None	N/A
3	Portland General Electric Co.	Angela Gaines		Abstain	N/A
3	PPL - Louisville Gas and Electric Co.	Charles Freibert		Affirmative	N/A
3	PSEG - Public Service Electric and Gas Co.	Jeffrey Mueller		Affirmative	N/A



<b>Segment</b>	<b>Organization</b>	<b>Voter</b>	<b>Designated Proxy</b>	<b>Ballot</b>	<b>NERC Memo</b>
3	Puget Sound Energy, Inc.	Lynda Kupfer		None	N/A
3	Sacramento Municipal Utility District	Nicole Looney	Joe Tarantino	Affirmative	N/A
3	Salt River Project	Rudy Navarro		Negative	Comments Submitted
3	Santee Cooper	James Poston		Negative	Comments Submitted
3	SCANA - South Carolina Electric and Gas Co.	Clay Young		None	N/A
3	Seattle City Light	Tuan Tran		Affirmative	N/A
3	Seminole Electric Cooperative, Inc.	James Frauen		Negative	Comments Submitted
3	Sempra - San Diego Gas and Electric	Bridget Silvia		Affirmative	N/A
3	Snohomish County PUD No. 1	Mark Oens		Abstain	N/A
3	Southern Company - Alabama Power Company	R. Scott Moore		Negative	Comments Submitted
3	Southern Indiana Gas and Electric Co.	Fred Frederick		Affirmative	N/A
3	Tacoma Public Utilities (Tacoma, WA)	Marc Donaldson		Affirmative	N/A
3	Tallahassee Electric (City of Tallahassee, FL)	John Williams		None	N/A
3	TECO - Tampa Electric Co.	Ronald Donahey		None	N/A
3	Tennessee Valley Authority	Ian Grant		Affirmative	N/A
3	WEC Energy Group, Inc.	Thomas Breene		Affirmative	N/A
3	Westar Energy	Bo Jones		Affirmative	N/A
3	Xcel Energy, Inc.	Michael Ibold		Affirmative	N/A
4	American Public Power Association	Jack Cashin		None	N/A

Segment	Organization	Voter	Designated Proxy	Ballot	NERC Memo
4	Austin Energy	Esther Weekes		Affirmative	N/A
4	FirstEnergy - FirstEnergy Corporation	Anthony Solic		Affirmative	N/A
4	Florida Municipal Power Agency	Carol Chinn	Brandon McCormick	Negative	Comments Submitted
4	Georgia System Operations Corporation	Guy Andrews		Affirmative	N/A
4	Keys Energy Services	Jeffrey Partington	Brandon McCormick	Negative	Comments Submitted
4	North Carolina Electric Membership Corporation	John Lemire	Scott Brame	Negative	Third-Party Comments
4	Oklahoma Municipal Power Authority	Ashley Stringer		None	N/A
4	Public Utility District No. 1 of Snohomish County	John Martinsen		Abstain	N/A
4	Sacramento Municipal Utility District	Beth Tincher	Joe Tarantino	Affirmative	N/A
4	Seattle City Light	Hao Li		Affirmative	N/A
4	Seminole Electric Cooperative, Inc.	Michael Ward		Negative	Comments Submitted
4	South Mississippi Electric Power Association	Steve McElhane		None	N/A
4	Tacoma Public Utilities (Tacoma, WA)	Hien Ho		Affirmative	N/A
4	Utility Services, Inc.	Brian Evans-Mongeon		Abstain	N/A
4	WEC Energy Group, Inc.	Anthony Jankowski		Affirmative	N/A
5	AEP	Thomas Foltz		Negative	Comments Submitted
5	Ameren - Ameren Missouri	Sam Dwyer		None	N/A
5	APS - Arizona Public Service Co.	Kasey Bohannon		Negative	Comments Submitted

<b>Segment</b>	<b>Organization</b>	<b>Voter</b>	<b>Designated Proxy</b>	<b>Ballot</b>	<b>NERC Memo</b>
5	Associated Electric Cooperative, Inc.	Brad Haralson		Affirmative	N/A
5	Austin Energy	Jeanie Doty		Affirmative	N/A
5	Avista - Avista Corporation	Glen Farmer		Affirmative	N/A
5	Basin Electric Power Cooperative	Mike Kraft		Affirmative	N/A
5	Berkshire Hathaway - NV Energy	Eric Schwarzrock	Jeffrey Watkins	Negative	Comments Submitted
5	Boise-Kuna Irrigation District - Lucky Peak Power Plant Project	Mike Kukla		Affirmative	N/A
5	Bonneville Power Administration	Francis Halpin		Affirmative	N/A
5	Brazos Electric Power Cooperative, Inc.	Shari Heino		None	N/A
5	California Department of Water Resources	ASM Mostafa		None	N/A
5	Choctaw Generation Limited Partnership, LLLP	Rob Watson		Negative	Third-Party Comments
5	City of Independence, Power and Light Department	Jim Nail		None	N/A
5	Cleco Corporation	Stephanie Huffman	Louis Guidry	Affirmative	N/A
5	CMS Energy - Consumers Energy Company	David Greyerbiehl		Affirmative	N/A
5	Colorado Springs Utilities	Jeff Icke		None	N/A
5	Con Ed - Consolidated Edison Co. of New York	Dermot Smyth		Affirmative	N/A
5	Duke Energy	Dale Goodwine	Colby Bellville	Affirmative	N/A
5	Edison International - Southern California Edison Company	Thomas Rafferty		Affirmative	N/A
5	Eversource Energy	Timothy Reyher		Affirmative	N/A

Segment	Organization	Voter	Designated Proxy	Ballot	NERC Memo
5	Exelon	Ruth Miller		Negative	Comments Submitted
5	FirstEnergy - FirstEnergy Solutions	Robert Loy		Affirmative	N/A
5	Florida Municipal Power Agency	David Schumann	Brandon McCormick	Negative	Comments Submitted
5	Great Plains Energy - Kansas City Power and Light Co.	Harold Wyble	Douglas Webb	Affirmative	N/A
5	Great River Energy	Preston Walsh		Affirmative	N/A
5	Herb Schrayshuen	Herb Schrayshuen		Affirmative	N/A
5	JEA	John Babik		None	N/A
5	Kissimmee Utility Authority	Mike Blough	Brandon McCormick	Negative	Comments Submitted
5	Lakeland Electric	Jim Howard		Affirmative	N/A
5	Lincoln Electric System	Kayleigh Wilkerson		Affirmative	N/A
5	Lower Colorado River Authority	Wesley Maurer		Negative	Comments Submitted
5	Luminant - Luminant Generation Company LLC	Alshare Hughes		Abstain	N/A
5	Manitoba Hydro	Yuguang Xiao		Negative	Comments Submitted
5	Massachusetts Municipal Wholesale Electric Company	David Gordon		Abstain	N/A
5	MEAG Power	Steven Grego	Scott Miller	Abstain	N/A
5	Muscatine Power and Water	Neal Nelson		None	N/A
5	National Grid USA	Elizabeth Spivak		None	N/A
5	NB Power Corporation	Laura McLeod		Abstain	N/A

Segment	Organization	Voter	Designated Proxy	Ballot	NERC Memo
5	Nebraska Public Power District	Don Schmit		Abstain	N/A
5	NiSource - Northern Indiana Public Service Co.	Sarah Gasienica		Negative	Comments Submitted
5	North Carolina Electric Membership Corporation	Robert Beadle	Scott Brame	Negative	Third-Party Comments
5	Northern California Power Agency	Marty Hostler		Negative	Comments Submitted
5	OGE Energy - Oklahoma Gas and Electric Co.	John Rhea		Affirmative	N/A
5	Oglethorpe Power Corporation	Donna Johnson		None	N/A
5	Omaha Public Power District	Mahmood Safi		Negative	Comments Submitted
5	Orlando Utilities Commission	Richard Kinas		None	N/A
5	Pacific Gas and Electric Company	Alex Chua		None	N/A
5	Portland General Electric Co.	Ryan Olson		Abstain	N/A
5	PPL - Louisville Gas and Electric Co.	Dan Wilson		Affirmative	N/A
5	PSEG - PSEG Fossil LLC	Tim Kucey		Affirmative	N/A
5	Public Utility District No. 1 of Snohomish County	Sam Nietfeld		Abstain	N/A
5	Public Utility District No. 2 of Grant County, Washington	Alex Ybarra		None	N/A
5	Puget Sound Energy, Inc.	Eleanor Ewry		None	N/A
5	Sacramento Municipal Utility District	Susan Oto	Joe Tarantino	Affirmative	N/A
5	Salt River Project	Kevin Nielsen		None	N/A
5	Santee Cooper	Tommy Curtis		Negative	Comments Submitted

<b>Segment</b>	<b>Organization</b>	<b>Voter</b>	<b>Designated Proxy</b>	<b>Ballot</b>	<b>NERC Memo</b>
5	SCANA - South Carolina Electric and Gas Co.	Alyssa Hubbard		Affirmative	N/A
5	Seattle City Light	Mike Haynes		Affirmative	N/A
5	Seminole Electric Cooperative, Inc.	Brenda Atkins		None	N/A
5	Sempra - San Diego Gas and Electric	Jerome Gobby		Affirmative	N/A
5	Southern Company - Southern Company Generation	William D. Shultz		Negative	Comments Submitted
5	SunPower	Bradley Collard		Affirmative	N/A
5	Tacoma Public Utilities (Tacoma, WA)	Chris Mattson		Affirmative	N/A
5	TECO - Tampa Electric Co.	R James Rocha		None	N/A
5	Tennessee Valley Authority	M Lee Thomas		Affirmative	N/A
5	Tri-State G and T Association, Inc.	Mark Stein		None	N/A
5	WEC Energy Group, Inc.	Linda Horn		Affirmative	N/A
5	Westar Energy	Laura Cox		Affirmative	N/A
5	Xcel Energy, Inc.	Gerry Huitt		Affirmative	N/A
6	AEP - AEP Marketing	Dan Ewing		Negative	Comments Submitted
6	Ameren - Ameren Services	Robert Quinlivan		None	N/A
6	APS - Arizona Public Service Co.	Bobbi Welch		Negative	Comments Submitted
6	Austin Energy	Andrew Gallo		Affirmative	N/A
6	Basin Electric Power Cooperative	Paul Huettl		Affirmative	N/A
6	Berkshire Hathaway - PacifiCorp	Sandra Shaffer		Affirmative	N/A

Segment	Organization	Voter	Designated Proxy	Ballot	NERC Memo
6	Black Hills Corporation	Eric Scherr		None	N/A
6	Bonneville Power Administration	Andrew Meyers		Affirmative	N/A
6	Cleco Corporation	Robert Hirchak	Louis Guidry	Affirmative	N/A
6	Colorado Springs Utilities	Shannon Fair		None	N/A
6	Con Ed - Consolidated Edison Co. of New York	Robert Winston		Affirmative	N/A
6	Duke Energy	Greg Cecil		Affirmative	N/A
6	Edison International - Southern California Edison Company	Kenya Streeter		Affirmative	N/A
6	Entergy	Julie Hall		Affirmative	N/A
6	Exelon	Becky Webb		Negative	Comments Submitted
6	FirstEnergy - FirstEnergy Solutions	Ann Ivanc		Affirmative	N/A
6	Florida Municipal Power Agency	Richard Montgomery	Brandon McCormick	Negative	Comments Submitted
6	Florida Municipal Power Pool	Tom Reedy	Brandon McCormick	Negative	Comments Submitted
6	Great Plains Energy - Kansas City Power and Light Co.	Chris Bridges	Douglas Webb	Affirmative	N/A
6	Great River Energy	Donna Stephenson	Michael Brytowski	None	N/A
6	Lakeland Electric	Paul Shipps		None	N/A
6	Lincoln Electric System	Eric Ruskamp		Affirmative	N/A
6	Los Angeles Department of Water and Power	Anton Vu		None	N/A
6	Lower Colorado River Authority	Michael Shaw		Abstain	N/A
6	Luminant - Luminant Energy	Brenda Hampton		Abstain	N/A

Segment	Organization	Voter	Designated Proxy	Ballot	NERC Memo
6	Manitoba Hydro	Blair Mukanik		Negative	Comments Submitted
6	Modesto Irrigation District	James McFall	Nick Braden	Affirmative	N/A
6	Muscatine Power and Water	Ryan Streck		Affirmative	N/A
6	New York Power Authority	Shivaz Chopra		Affirmative	N/A
6	NextEra Energy - Florida Power and Light Co.	Silvia Mitchell		None	N/A
6	NiSource - Northern Indiana Public Service Co.	Joe O'Brien		Negative	Comments Submitted
6	Northern California Power Agency	Dennis Sismaet		Negative	Comments Submitted
6	OGE Energy - Oklahoma Gas and Electric Co.	Jerry Nottnagel		Affirmative	N/A
6	Platte River Power Authority	Sabrina Martz		Affirmative	N/A
6	Portland General Electric Co.	Daniel Mason		Abstain	N/A
6	PPL - Louisville Gas and Electric Co.	Linn Oelker		Affirmative	N/A
6	PSEG - PSEG Energy Resources and Trade LLC	Karla Barton		Affirmative	N/A
6	Public Utility District No. 2 of Grant County, Washington	LeRoy Patterson		None	N/A
6	Sacramento Municipal Utility District	Jamie Cutlip	Joe Tarantino	Affirmative	N/A
6	Salt River Project	Bobby Olsen		None	N/A
6	Santee Cooper	Michael Brown		Negative	Comments Submitted
6	SCANA - South Carolina Electric and Gas Co.	John Folsom		Affirmative	N/A
6	Seattle City Light	Charles Freeman		None	N/A



Segment	Organization	Voter	Designated Proxy	Ballot	NERC Memo
6	Seminole Electric Cooperative, Inc.	Trudy Novak		Negative	Comments Submitted
6	Snohomish County PUD No. 1	Franklin Lu		Abstain	N/A
6	Southern Company - Southern Company Generation and Energy Marketing	Jennifer Sykes		Negative	Comments Submitted
6	Southern Indiana Gas and Electric Co.	Brad Lisembee		Affirmative	N/A
6	Tennessee Valley Authority	Marjorie Parsons		Affirmative	N/A
6	WEC Energy Group, Inc.	Scott Hoggatt		None	N/A
6	Westar Energy	Megan Wagner		Affirmative	N/A
7	Luminant Mining Company LLC	Stewart Rake		None	N/A
8	David Kiguel	David Kiguel		Affirmative	N/A
8	Foundation for Resilient Societies	William Harris		None	N/A
8	Massachusetts Attorney General	Frederick Plett		Affirmative	N/A
9	Commonwealth of Massachusetts Department of Public Utilities	Donald Nelson		Affirmative	N/A
10	Florida Reliability Coordinating Council	Peter Heidrich		None	N/A
10	Midwest Reliability Organization	Russel Mountjoy		Affirmative	N/A
10	New York State Reliability Council	ALAN ADAMSON		Affirmative	N/A
10	Northeast Power Coordinating Council	Guy V. Zito		Affirmative	N/A
10	ReliabilityFirst	Anthony Jablonski		Affirmative	N/A

Segment	Organization	Voter	Designated Proxy	Ballot	NERC Memo
10	SERC Reliability Corporation	David Greene		Affirmative	N/A
10	Texas Reliability Entity, Inc.	Rachel Coyne		Abstain	N/A
10	Western Electricity Coordinating Council	Steven Rueckert		Affirmative	N/A

Showing 1 to 303 of 303 entries

Previous  Next

## BALLOT RESULTS

Comment: [View Comment Results \(/CommentResults/Index/95\)](#)

**Ballot Name:** 2013-03 Geomagnetic Disturbance Mitigation TPL-007-2 IN 1 NB

**Voting Start Date:** 8/2/2017 12:01:00 AM

**Voting End Date:** 8/11/2017 8:00:00 PM

**Ballot Type:** NB

**Ballot Activity:** IN

**Ballot Series:** 1

**Total # Votes:** 226

**Total Ballot Pool:** 293

**Quorum:** 77.13

**Weighted Segment Value:** 69.19

Segment	Ballot Pool	Segment Weight	Affirmative Votes	Affirmative Fraction	Negative Votes	Negative Fraction	Abstain	No Vote
Segment: 1	71	1	32	0.696	14	0.304	15	10
Segment: 2	7	0.3	2	0.2	1	0.1	1	3
Segment: 3	69	1	28	0.683	13	0.317	13	15
Segment: 4	15	1	7	0.636	4	0.364	2	2
Segment: 5	68	1	24	0.686	11	0.314	13	20
Segment: 6	50	1	18	0.643	10	0.357	8	14
Segment: 7	1	0	0	0	0	0	0	1
Segment: 8	3	0.2	2	0.2	0	0	0	1
Segment: 9	1	0.1	1	0.1	0	0	0	0

Segment	Ballot Pool	Segment Weight	Affirmative Votes	Affirmative Fraction	Negative Votes	Negative Fraction	Abstain	No Vote
Segment: 10	8	0.5	5	0.5	0	0	2	1
Totals:	293	6.1	119	4.344	53	1.756	54	67

## BALLOT POOL MEMBERS

Show  entries

Search:

Segment	Organization	Voter	Designated Proxy	Ballot	NERC Memo
1	AEP - AEP Service Corporation	Dennis Sauriol		Negative	Comments Submitted
1	Ameren - Ameren Services	Eric Scott		None	N/A
1	American Transmission Company, LLC	Lauren Price		Abstain	N/A
1	APS - Arizona Public Service Co.	Michelle Amarantos		Negative	Comments Submitted
1	Associated Electric Cooperative, Inc.	Mark Riley		Affirmative	N/A
1	Balancing Authority of Northern California	Kevin Smith	Joe Tarantino	Affirmative	N/A
1	BC Hydro and Power Authority	Patricia Robertson		Abstain	N/A
1	Berkshire Hathaway Energy - MidAmerican Energy Co.	Terry Harbour		Negative	Comments Submitted
1	Bonneville Power Administration	Kammy Rogers-Holliday		Affirmative	N/A

Segment	Organization	Voter	Designated Proxy	Ballot	NERC Memo
1	Brazos Electric Power Cooperative, Inc.	Tony Kroskey		Negative	Comments Submitted
1	CenterPoint Energy Houston Electric, LLC	John Brockhan		Abstain	N/A
1	Central Hudson Gas & Electric Corp.	Frank Pace		Affirmative	N/A
1	City Utilities of Springfield, Missouri	Michael Buyce		None	N/A
1	Cleco Corporation	John Lindsey	Louis Guidry	Affirmative	N/A
1	Con Ed - Consolidated Edison Co. of New York	Daniel Grinkevich		Affirmative	N/A
1	CPS Energy	Gladys DeLaO		None	N/A
1	Duke Energy	Doug Hils		Affirmative	N/A
1	Entergy - Entergy Services, Inc.	Oliver Burke		Affirmative	N/A
1	Eversource Energy	Quintin Lee		Affirmative	N/A
1	Exelon	Chris Scanlon		Abstain	N/A
1	FirstEnergy - FirstEnergy Corporation	Karen Yoder		Affirmative	N/A
1	Georgia Transmission Corporation	Jason Snodgrass	Greg Davis	Affirmative	N/A
1	Great Plains Energy - Kansas City Power and Light Co.	James McBee	Douglas Webb	Affirmative	N/A
1	Great River Energy	Gordon Pietsch		Affirmative	N/A
1	Hydro One Networks, Inc.	Payam Farahbakhsh		Negative	Comments Submitted
1	Hydro-Québec TransEnergie	Nicolas Turcotte		Negative	Comments Submitted
1	IDACORP - Idaho Power Company	Laura Nelson		Affirmative	N/A
1	Imperial Irrigation District	Jesus Sammy Alcaraz		None	N/A

<b>Segment</b>	<b>Organization</b>	<b>Voter</b>	<b>Designated Proxy</b>	<b>Ballot</b>	<b>NERC Memo</b>
1	International Transmission Company Holdings Corporation	Michael Moltane	Stephanie Burns	None	N/A
1	KAMO Electric Cooperative	Walter Kenyon		None	N/A
1	Lakeland Electric	Larry Watt		None	N/A
1	Lincoln Electric System	Danny Pudenz		Abstain	N/A
1	Long Island Power Authority	Robert Ganley		Abstain	N/A
1	Los Angeles Department of Water and Power	faranak sarbaz		Abstain	N/A
1	M and A Electric Power Cooperative	William Price		Affirmative	N/A
1	Manitoba Hydro	Mike Smith		Negative	Comments Submitted
1	MEAG Power	David Weekley	Scott Miller	Abstain	N/A
1	Minnkota Power Cooperative Inc.	Theresa Allard		Abstain	N/A
1	Muscatine Power and Water	Andy Kurriger		Affirmative	N/A
1	N.W. Electric Power Cooperative, Inc.	Mark Ramsey		Affirmative	N/A
1	National Grid USA	Michael Jones		Affirmative	N/A
1	Nebraska Public Power District	Jamison Cawley		Abstain	N/A
1	New York Power Authority	Salvatore Spagnolo		Affirmative	N/A
1	NextEra Energy - Florida Power and Light Co.	Mike ONeil		Affirmative	N/A
1	NiSource - Northern Indiana Public Service Co.	Steve Toosevich		Negative	Comments Submitted
1	Northeast Missouri Electric Power Cooperative	Kevin White		Affirmative	N/A
1	NorthWestern Energy	Belinda Tierney		None	N/A

<b>Segment</b>	<b>Organization</b>	<b>Voter</b>	<b>Designated Proxy</b>	<b>Ballot</b>	<b>NERC Memo</b>
1	OGE Energy - Oklahoma Gas and Electric Co.	Terri Pyle		Affirmative	N/A
1	Omaha Public Power District	Doug Peterchuck		Negative	Comments Submitted
1	Peak Reliability	Scott Downey		Affirmative	N/A
1	PNM Resources - Public Service Company of New Mexico	Laurie Williams		Affirmative	N/A
1	Portland General Electric Co.	Scott Smith		None	N/A
1	PPL Electric Utilities Corporation	Brenda Truhe		Abstain	N/A
1	PSEG - Public Service Electric and Gas Co.	Joseph Smith		Abstain	N/A
1	Public Utility District No. 1 of Snohomish County	Long Duong		Abstain	N/A
1	Sacramento Municipal Utility District	Arthur Starkovich	Joe Tarantino	Affirmative	N/A
1	Salt River Project	Steven Cobb		Negative	Comments Submitted
1	Santee Cooper	Shawn Abrams		Abstain	N/A
1	SCANA - South Carolina Electric and Gas Co.	Tom Hanzlik		Affirmative	N/A
1	Seattle City Light	Pawel Krupa		None	N/A
1	Seminole Electric Cooperative, Inc.	Mark Churilla	Bret Galbraith	Negative	Comments Submitted
1	Sempra - San Diego Gas and Electric	Martine Blair		Affirmative	N/A
1	Sho-Me Power Electric Cooperative	Peter Dawson		Affirmative	N/A
1	Southern Company - Southern Company Services, Inc.	Katherine Prewitt		Negative	Comments Submitted

Segment	Organization	Voter	Designated Proxy	Ballot	NERC Memo
1	Sunflower Electric Power Corporation	Paul Mehlhaff		Negative	Comments Submitted
1	Tacoma Public Utilities (Tacoma, WA)	John Merrell		Affirmative	N/A
1	Tallahassee Electric (City of Tallahassee, FL)	Scott Langston		Abstain	N/A
1	Tennessee Valley Authority	Howell Scott		Affirmative	N/A
1	Tri-State G and T Association, Inc.	Tracy Sliman		Negative	Comments Submitted
1	Westar Energy	Kevin Giles		Affirmative	N/A
1	Western Area Power Administration	sean erickson		Affirmative	N/A
2	California ISO	Richard Vine		None	N/A
2	Electric Reliability Council of Texas, Inc.	Brandon Gleason		None	N/A
2	ISO New England, Inc.	Michael Puscas	Joshua Eason	Negative	Comments Submitted
2	Midcontinent ISO, Inc.	Ellen Oswald		None	N/A
2	New York Independent System Operator	Gregory Campoli		Abstain	N/A
2	PJM Interconnection, L.L.C.	Mark Holman		Affirmative	N/A
2	Southwest Power Pool, Inc. (RTO)	Charles Yeung		Affirmative	N/A
3	AEP	Aaron Austin		Negative	Comments Submitted
3	AES - Indianapolis Power and Light Co.	Bette White		None	N/A
3	APS - Arizona Public Service Co.	Vivian Vo		Negative	Comments Submitted
3	Austin Energy	W. Dwayne Preston		Abstain	N/A
3	Avista - Avista Corporation	Scott Kinney		None	N/A



Segment	Organization	Voter	Designated Proxy	Ballot	NERC Memo
3	Basin Electric Power Cooperative	Jeremy Voll		Affirmative	N/A
3	BC Hydro and Power Authority	Hootan Jarollahi		Abstain	N/A
3	Berkshire Hathaway Energy - MidAmerican Energy Co.	Annette Johnston	Darnez Gresham	Negative	Comments Submitted
3	Black Hills Corporation	Eric Egge	Maryanne Darling-Reich	None	N/A
3	Bonneville Power Administration	Rebecca Berdahl		Affirmative	N/A
3	Central Electric Power Cooperative (Missouri)	Adam Weber		Affirmative	N/A
3	City of Vero Beach	Ginny Beigel	Brandon McCormick	Negative	Comments Submitted
3	Clark Public Utilities	Jack Stamper		None	N/A
3	Cleco Corporation	Michelle Corley	Louis Guidry	Affirmative	N/A
3	CMS Energy - Consumers Energy Company	Karl Blaszkowski		Affirmative	N/A
3	Colorado Springs Utilities	Hillary Dobson		None	N/A
3	Con Ed - Consolidated Edison Co. of New York	Peter Yost		Affirmative	N/A
3	Cowlitz County PUD	Russell Noble		Affirmative	N/A
3	Dominion - Dominion Resources, Inc.	Connie Lowe		Abstain	N/A
3	DTE Energy - Detroit Edison Company	Karie Barczak		Affirmative	N/A
3	Duke Energy	Lee Schuster		Affirmative	N/A
3	Edison International - Southern California Edison Company	Romel Aquino		Affirmative	N/A
3	Eversource Energy	Mark Kenny		None	N/A
3	Exelon	John Bee		Abstain	N/A

<b>Segment</b>	<b>Organization</b>	<b>Voter</b>	<b>Designated Proxy</b>	<b>Ballot</b>	<b>NERC Memo</b>
3	FirstEnergy - FirstEnergy Corporation	Aaron Ghodooshim		Affirmative	N/A
3	Florida Municipal Power Agency	Joe McKinney	Brandon McCormick	Negative	Comments Submitted
3	Gainesville Regional Utilities	Ken Simmons		Negative	Comments Submitted
3	Georgia System Operations Corporation	Scott McGough		Affirmative	N/A
3	Great Plains Energy - Kansas City Power and Light Co.	Jessica Tucker	Douglas Webb	Affirmative	N/A
3	Great River Energy	Brian Glover		Affirmative	N/A
3	Hydro One Networks, Inc.	Paul Malozewski		None	N/A
3	Lakeland Electric	David Hadzima		None	N/A
3	Lincoln Electric System	Jason Fortik		Abstain	N/A
3	M and A Electric Power Cooperative	Stephen Pogue		Affirmative	N/A
3	Manitoba Hydro	Karim Abdel-Hadi		Negative	Comments Submitted
3	MEAG Power	Roger Brand	Scott Miller	Abstain	N/A
3	Modesto Irrigation District	Jack Savage	Nick Braden	Abstain	N/A
3	Muscatine Power and Water	Seth Shoemaker		Affirmative	N/A
3	National Grid USA	Brian Shanahan		Affirmative	N/A
3	Nebraska Public Power District	Tony Eddleman		Abstain	N/A
3	New York Power Authority	David Rivera	Shelly Dineen	Affirmative	N/A
3	NiSource - Northern Indiana Public Service Co.	Aimee Harris		Negative	Comments Submitted
3	NW Electric Power Cooperative, Inc.	John Stickley		Affirmative	N/A

<b>Segment</b>	<b>Organization</b>	<b>Voter</b>	<b>Designated Proxy</b>	<b>Ballot</b>	<b>NERC Memo</b>
3	Ocala Utility Services	Randy Hahn		Negative	Comments Submitted
3	OGE Energy - Oklahoma Gas and Electric Co.	Donald Hargrove		Affirmative	N/A
3	Omaha Public Power District	Aaron Smith		Negative	Comments Submitted
3	Owensboro Municipal Utilities	Thomas Lyons		Affirmative	N/A
3	Platte River Power Authority	Jeff Landis		Affirmative	N/A
3	PNM Resources - Public Service Company of New Mexico	Lynn Goldstein		None	N/A
3	Portland General Electric Co.	Angela Gaines		Abstain	N/A
3	PPL - Louisville Gas and Electric Co.	Charles Freibert		None	N/A
3	PSEG - Public Service Electric and Gas Co.	Jeffrey Mueller		Abstain	N/A
3	Puget Sound Energy, Inc.	Lynda Kupfer		None	N/A
3	Sacramento Municipal Utility District	Nicole Looney	Joe Tarantino	Affirmative	N/A
3	Salt River Project	Rudy Navarro		Negative	Comments Submitted
3	Santee Cooper	James Poston		Abstain	N/A
3	SCANA - South Carolina Electric and Gas Co.	Clay Young		None	N/A
3	Seattle City Light	Tuan Tran		None	N/A
3	Seminole Electric Cooperative, Inc.	James Frauen		Negative	Comments Submitted
3	Sempra - San Diego Gas and Electric	Bridget Silvia		Affirmative	N/A
3	Snohomish County PUD	Mark Oens		Abstain	N/A

<b>Segment</b>	<b>Organization</b>	<b>Voter</b>	<b>Designated Proxy</b>	<b>Ballot</b>	<b>NERC Memo</b>
3	Southern Company - Alabama Power Company	R. Scott Moore		Negative	Comments Submitted
3	Tacoma Public Utilities (Tacoma, WA)	Marc Donaldson		Affirmative	N/A
3	Tallahassee Electric (City of Tallahassee, FL)	John Williams		None	N/A
3	TECO - Tampa Electric Co.	Ronald Donahey		None	N/A
3	Tennessee Valley Authority	Ian Grant		Affirmative	N/A
3	WEC Energy Group, Inc.	Thomas Breene		Affirmative	N/A
3	Westar Energy	Bo Jones		Affirmative	N/A
3	Xcel Energy, Inc.	Michael Ibold		Abstain	N/A
4	American Public Power Association	Jack Cashin		None	N/A
4	Austin Energy	Esther Weekes		Affirmative	N/A
4	FirstEnergy - FirstEnergy Corporation	Anthony Solic		Affirmative	N/A
4	Florida Municipal Power Agency	Carol Chinn	Brandon McCormick	Negative	Comments Submitted
4	Georgia System Operations Corporation	Guy Andrews		Affirmative	N/A
4	Keys Energy Services	Jeffrey Partington	Brandon McCormick	Negative	Comments Submitted
4	North Carolina Electric Membership Corporation	John Lemire	Scott Brame	Negative	Comments Submitted
4	Public Utility District No. 1 of Snohomish County	John Martinsen		Abstain	N/A
4	Sacramento Municipal Utility District	Beth Tincher	Joe Tarantino	Affirmative	N/A
4	Seattle City Light	Hao Li		Affirmative	N/A
4	Seminole Electric Cooperative, Inc.	Michael Ward		Negative	Comments Submitted

<b>Segment</b>	<b>Organization</b>	<b>Voter</b>	<b>Designated Proxy</b>	<b>Ballot</b>	<b>NERC Memo</b>
4	South Mississippi Electric Power Association	Steve McElhaney		None	N/A
4	Tacoma Public Utilities (Tacoma, WA)	Hien Ho		Affirmative	N/A
4	Utility Services, Inc.	Brian Evans-Mongeon		Abstain	N/A
4	WEC Energy Group, Inc.	Anthony Jankowski		Affirmative	N/A
5	AEP	Thomas Foltz		Negative	Comments Submitted
5	Ameren - Ameren Missouri	Sam Dwyer		None	N/A
5	APS - Arizona Public Service Co.	Kasey Bohannon		Negative	Comments Submitted
5	Associated Electric Cooperative, Inc.	Brad Haralson		Affirmative	N/A
5	Austin Energy	Jeanie Doty		Affirmative	N/A
5	Avista - Avista Corporation	Glen Farmer		Affirmative	N/A
5	Basin Electric Power Cooperative	Mike Kraft		Affirmative	N/A
5	Berkshire Hathaway - NV Energy	Eric Schwarzrock	Jeffrey Watkins	Affirmative	N/A
5	Boise-Kuna Irrigation District - Lucky Peak Power Plant Project	Mike Kukla		Affirmative	N/A
5	Bonneville Power Administration	Francis Halpin		Affirmative	N/A
5	Brazos Electric Power Cooperative, Inc.	Shari Heino		None	N/A
5	California Department of Water Resources	ASM Mostafa		None	N/A
5	Choctaw Generation Limited Partnership, LLLP	Rob Watson		Negative	Comments Submitted

<b>Segment</b>	<b>Organization</b>	<b>Voter</b>	<b>Designated Proxy</b>	<b>Ballot</b>	<b>NERC Memo</b>
5	City of Independence, Power and Light Department	Jim Nail		None	N/A
5	Cleco Corporation	Stephanie Huffman	Louis Guidry	Affirmative	N/A
5	CMS Energy - Consumers Energy Company	David Greyerbiehl		Abstain	N/A
5	Colorado Springs Utilities	Jeff Icke		None	N/A
5	Con Ed - Consolidated Edison Co. of New York	Dermot Smyth		Affirmative	N/A
5	Duke Energy	Dale Goodwine	Colby Bellville	Affirmative	N/A
5	Edison International - Southern California Edison Company	Thomas Rafferty		Affirmative	N/A
5	Eversource Energy	Timothy Reyher		Affirmative	N/A
5	Exelon	Ruth Miller		Abstain	N/A
5	FirstEnergy - FirstEnergy Solutions	Robert Loy		Affirmative	N/A
5	Florida Municipal Power Agency	David Schumann	Brandon McCormick	Negative	Comments Submitted
5	Great Plains Energy - Kansas City Power and Light Co.	Harold Wyble	Douglas Webb	Affirmative	N/A
5	Great River Energy	Preston Walsh		Affirmative	N/A
5	Herb Schrayshuen	Herb Schrayshuen		Affirmative	N/A
5	JEA	John Babik		None	N/A
5	Kissimmee Utility Authority	Mike Blough	Brandon McCormick	Negative	Comments Submitted
5	Lakeland Electric	Jim Howard		Affirmative	N/A
5	Lincoln Electric System	Kayleigh Wilkerson		Abstain	N/A

<b>Segment</b>	<b>Organization</b>	<b>Voter</b>	<b>Designated Proxy</b>	<b>Ballot</b>	<b>NERC Memo</b>
5	Lower Colorado River Authority	Wesley Maurer		Negative	Comments Submitted
5	Luminant - Luminant Generation Company LLC	Alshare Hughes		None	N/A
5	Manitoba Hydro	Yuguang Xiao		Negative	Comments Submitted
5	Massachusetts Municipal Wholesale Electric Company	David Gordon		Abstain	N/A
5	MEAG Power	Steven Grego	Scott Miller	Abstain	N/A
5	Muscatine Power and Water	Neal Nelson		None	N/A
5	National Grid USA	Elizabeth Spivak		None	N/A
5	NB Power Corporation	Laura McLeod		Abstain	N/A
5	Nebraska Public Power District	Don Schmit		Abstain	N/A
5	NiSource - Northern Indiana Public Service Co.	Sarah Gasienica		Negative	Comments Submitted
5	Northern California Power Agency	Marty Hostler		Negative	Comments Submitted
5	OGE Energy - Oklahoma Gas and Electric Co.	John Rhea		Affirmative	N/A
5	Oglethorpe Power Corporation	Donna Johnson		None	N/A
5	Omaha Public Power District	Mahmood Safi		Negative	Comments Submitted
5	Orlando Utilities Commission	Richard Kinass		None	N/A
5	Pacific Gas and Electric Company	Alex Chua		None	N/A
5	Portland General Electric Co.	Ryan Olson		Abstain	N/A

<b>Segment</b>	<b>Organization</b>	<b>Voter</b>	<b>Designated Proxy</b>	<b>Ballot</b>	<b>NERC Memo</b>
5	PPL - Louisville Gas and Electric Co.	Dan Wilson		Abstain	N/A
5	PSEG - PSEG Fossil LLC	Tim Kucey		Abstain	N/A
5	Public Utility District No. 1 of Snohomish County	Sam Nietfeld		Abstain	N/A
5	Public Utility District No. 2 of Grant County, Washington	Alex Ybarra		None	N/A
5	Puget Sound Energy, Inc.	Eleanor Ewry		None	N/A
5	Sacramento Municipal Utility District	Susan Oto	Joe Tarantino	Affirmative	N/A
5	Salt River Project	Kevin Nielsen		None	N/A
5	Santee Cooper	Tommy Curtis		Abstain	N/A
5	SCANA - South Carolina Electric and Gas Co.	Alyssa Hubbard		Affirmative	N/A
5	Seattle City Light	Mike Haynes		Affirmative	N/A
5	Seminole Electric Cooperative, Inc.	Brenda Atkins		None	N/A
5	Sempra - San Diego Gas and Electric	Jerome Gobby		Affirmative	N/A
5	Southern Company - Southern Company Generation	William D. Shultz		Negative	Comments Submitted
5	SunPower	Bradley Collard		Affirmative	N/A
5	Tacoma Public Utilities (Tacoma, WA)	Chris Mattson		Affirmative	N/A
5	TECO - Tampa Electric Co.	R James Rocha		None	N/A
5	Tennessee Valley Authority	M Lee Thomas		None	N/A
5	Tri-State G and T Association, Inc.	Mark Stein		None	N/A
5	WEC Energy Group, Inc.	Linda Horn		Abstain	N/A



<b>Segment</b>	<b>Organization</b>	<b>Voter</b>	<b>Designated Proxy</b>	<b>Ballot</b>	<b>NERC Memo</b>
5	Westar Energy	Laura Cox		None	N/A
6	AEP - AEP Marketing	Dan Ewing		Negative	Comments Submitted
6	Ameren - Ameren Services	Robert Quinlivan		None	N/A
6	APS - Arizona Public Service Co.	Bobbi Welch		Negative	Comments Submitted
6	Austin Energy	Andrew Gallo		Affirmative	N/A
6	Basin Electric Power Cooperative	Paul Huettl		Affirmative	N/A
6	Berkshire Hathaway - PacifiCorp	Sandra Shaffer		Affirmative	N/A
6	Black Hills Corporation	Eric Scherr		None	N/A
6	Bonneville Power Administration	Andrew Meyers		Affirmative	N/A
6	Cleco Corporation	Robert Hirschak	Louis Guidry	Affirmative	N/A
6	Colorado Springs Utilities	Shannon Fair		None	N/A
6	Con Ed - Consolidated Edison Co. of New York	Robert Winston		Affirmative	N/A
6	Duke Energy	Greg Cecil		Affirmative	N/A
6	Edison International - Southern California Edison Company	Kenya Streeter		Affirmative	N/A
6	Entergy	Julie Hall		Affirmative	N/A
6	Exelon	Becky Webb		Abstain	N/A
6	FirstEnergy - FirstEnergy Solutions	Ann Ivanc		Affirmative	N/A
6	Florida Municipal Power Agency	Richard Montgomery	Brandon McCormick	Negative	Comments Submitted
6	Florida Municipal Power Pool	Tom Reedy	Brandon McCormick	Negative	Comments Submitted

<b>Segment</b>	<b>Organization</b>	<b>Voter</b>	<b>Designated Proxy</b>	<b>Ballot</b>	<b>NERC Memo</b>
6	Great Plains Energy - Kansas City Power and Light Co.	Chris Bridges	Douglas Webb	Affirmative	N/A
6	Great River Energy	Donna Stephenson	Michael Brytowski	None	N/A
6	Lakeland Electric	Paul Shipps		None	N/A
6	Lincoln Electric System	Eric Ruskamp		Abstain	N/A
6	Los Angeles Department of Water and Power	Anton Vu		None	N/A
6	Lower Colorado River Authority	Michael Shaw		Negative	Comments Submitted
6	Luminant - Luminant Energy	Brenda Hampton		Abstain	N/A
6	Manitoba Hydro	Blair Mukanik		Negative	Comments Submitted
6	Modesto Irrigation District	James McFall	Nick Braden	Abstain	N/A
6	Muscatine Power and Water	Ryan Streck		Affirmative	N/A
6	New York Power Authority	Shivaz Chopra		Affirmative	N/A
6	NextEra Energy - Florida Power and Light Co.	Silvia Mitchell		None	N/A
6	NiSource - Northern Indiana Public Service Co.	Joe O'Brien		Negative	Comments Submitted
6	Northern California Power Agency	Dennis Sismaet		Negative	Comments Submitted
6	OGE Energy - Oklahoma Gas and Electric Co.	Jerry Nottmagel		Affirmative	N/A
6	Platte River Power Authority	Sabrina Martz		None	N/A
6	Portland General Electric Co.	Daniel Mason		Abstain	N/A
6	PPL - Louisville Gas and Electric Co.	Linn Oelker		None	N/A

Segment	Organization	Voter	Designated Proxy	Ballot	NERC Memo
6	PSEG - PSEG Energy Resources and Trade LLC	Karla Barton		Abstain	N/A
6	Public Utility District No. 2 of Grant County, Washington	LeRoy Patterson		None	N/A
6	Sacramento Municipal Utility District	Jamie Cutlip	Joe Tarantino	Affirmative	N/A
6	Salt River Project	Bobby Olsen		None	N/A
6	Santee Cooper	Michael Brown		Abstain	N/A
6	SCANA - South Carolina Electric and Gas Co.	John Folsom		Affirmative	N/A
6	Seattle City Light	Charles Freeman		None	N/A
6	Seminole Electric Cooperative, Inc.	Trudy Novak		Negative	Comments Submitted
6	Snohomish County PUD No. 1	Franklin Lu		Abstain	N/A
6	Southern Company - Southern Company Generation and Energy Marketing	Jennifer Sykes		Negative	Comments Submitted
6	Southern Indiana Gas and Electric Co.	Brad Lisembee		None	N/A
6	Tennessee Valley Authority	Marjorie Parsons		Affirmative	N/A
6	WEC Energy Group, Inc.	Scott Hoggatt		None	N/A
6	Westar Energy	Megan Wagner		Affirmative	N/A
7	Luminant Mining Company LLC	Stewart Rake		None	N/A
8	David Kiguel	David Kiguel		Affirmative	N/A
8	Foundation for Resilient Societies	William Harris		None	N/A
8	Massachusetts Attorney General	Frederick Plett		Affirmative	N/A

Segment	Organization	Voter	Designated Proxy	Ballot	NERC Memo
9	Commonwealth of Massachusetts Department of Public Utilities	Donald Nelson		Affirmative	N/A
10	Florida Reliability Coordinating Council	Peter Heidrich		None	N/A
10	Midwest Reliability Organization	Russel Mountjoy		Affirmative	N/A
10	New York State Reliability Council	ALAN ADAMSON		Affirmative	N/A
10	Northeast Power Coordinating Council	Guy V. Zito		Affirmative	N/A
10	ReliabilityFirst	Anthony Jablonski		Affirmative	N/A
10	SERC Reliability Corporation	David Greene		Affirmative	N/A
10	Texas Reliability Entity, Inc.	Rachel Coyne		Abstain	N/A
10	Western Electricity Coordinating Council	Steven Rueckert		Abstain	N/A

Showing 1 to 293 of 293 entries

Previous 1 Next

# Standards Announcement

## Project 2013-03 Geomagnetic Disturbance Mitigation TPL-007-2

Formal Comment Period Open through August 11, 2017  
Ballot Pools Forming through July 27, 2017

### [Now Available](#)

A 45-day formal comment period for **TPL-007-2 - Transmission System Planned Performance for Geomagnetic Disturbance Events**, is open through **8 p.m. Eastern, Friday, August 11, 2017**.

### Commenting

Use the [electronic form](#) to submit comments on the standard. If you experience any difficulties in using the electronic form, contact [Nasheema Santos](#). An unofficial Word version of the comment form is posted on the [project page](#).

### Join the Ballot Pools

Ballot pools are being formed through **8 p.m. Eastern, Thursday, July 27, 2017**. Registered Ballot Body members may join the ballot pools [here](#).

*If you are having difficulty accessing the SBS due to a forgotten password, incorrect credential error messages, or system lock-out, contact NERC IT support directly at <https://support.nerc.net/> (Monday – Friday, 8 a.m. - 5 p.m. Eastern).*

- *Passwords expire every **6 months** and must be reset.*
- *The SBS is **not** supported for use on mobile devices.*
- *Please be mindful of ballot and comment period closing dates. We ask to **allow at least 48 hours** for NERC support staff to assist with inquiries. Therefore, it is recommended that users try logging into their SBS accounts **prior to the last day** of a comment/ballot period.*

### Next Steps

Initial ballots for the standard and non-binding poll of the associated Violation Risk Factors and Violation Severity Levels will be conducted **August 2-11, 2017**.

For more information on the Standards Development Process, refer to the [Standard Processes Manual](#).

For more information or assistance, contact Senior Standards Developer, [Mark Olson](#) (via email) or at (404) 446-9760.

North American Electric Reliability Corporation  
3353 Peachtree Rd, NE  
Suite 600, North Tower  
Atlanta, GA 30326  
404-446-2560 | [www.nerc.com](http://www.nerc.com)

## Consideration of Comments

<b>Project Name:</b>	2013-03 Geomagnetic Disturbance Mitigation   TPL-007-2
Comment Period Start Date:	6/28/2017
Comment Period End Date:	8/11/2017
Associated Ballots:	2013-03 Geomagnetic Disturbance Mitigation TPL-007-2 IN 1 NB 2013-03 Geomagnetic Disturbance Mitigation TPL-007-2 IN 1 ST

There were 58 sets of responses, including comments from approximately 147 different people from approximately 106 companies representing 10 of the Industry Segments as shown in the table on the following pages.

All comments submitted can be reviewed in their original format on the [project page](#).

If you feel that your comment has been overlooked, please let us know immediately. Our goal is to give every comment serious consideration in this process. If you feel there has been an error or omission, you can contact the Senior Director of Standards and Education, [Howard Gugel](#) (via email) or at (404) 446-9693.

**Summary Consideration**

The standard drafting team (SDT) made non-substantive revisions to Measures M5 and M9, Rationales for Requirements R7, R11, and R12, including a correction to a chapter reference. Additionally, the singular use of “study” in the Violation Severity Levels (VSL) for Requirement R2 was deleted because there will be at least two studies (i.e., benchmark and supplemental), and the missing word “the” was added in the Moderate VSL for Requirement R4. For Requirement R8 in the VSLs, the text in the Lower VSL column was moved to be consistent with the order of the text in the other three columns.

The heading for Attachment 1 was corrected to properly link as a part of the standard and not to identify it as supplemental material. Other non-substantive revisions addressed punctuation, formatting, and conforming the document(s) to the NERC style guide, which included properly footnoting webpage links to reference documents.

Other supporting documents, such as, the Supplemental GMD Event white paper, Thermal Screening Criterion White Paper, and Transformer Thermal Impact Assessment White Paper all received non-substantive revisions addressed punctuation, formatting, and conforming the document(s) to the NERC style guide. A few clarifying revisions were made to address comments by stakeholders.

In the Implementation Plan, the SDT clarified the phase-in compliance dates for those Requirements that were tacitly incorporated into the effective date language by adding additional items under the phase-in compliance date section. Also, the SDT corrected a technical error regarding Requirement R6. For example, if the standard happens to be approved quickly by governmental authorities, Requirement R6 could become effective prior to the TPL-007-1 effective date. To correct this condition, the SDT provided a six-month phased-in implementation for Requirement R6.



## Questions

- 1. The SDT developed proposed Requirements R8 – R10 and the supplemental GMD event to address FERC concerns with the benchmark GMD event used in GMD Vulnerability Assessments. (Order No. 830 P.44, P.47-49, P.65). The requirements will obligate responsible entities to perform a supplemental GMD Vulnerability Assessment based on the supplemental GMD event that accounts for potential impacts of localized peak geoelectric fields. Do you agree with the proposed requirements? If you do not agree, or if you agree but have comments or suggestions for the proposed requirements provide your recommendation and explanation.**
- 2. The SDT developed the Supplemental GMD Event Description white paper to provide technical justification for the supplemental GMD event. The purpose of the supplemental GMD event description is to provide a defined event for assessing system performance for a GMD event which includes a local enhancement of the geomagnetic field. Do you agree with the proposed supplemental GMD event and the description in the white paper? If you do not agree, or if you agree but have comments or suggestions for the supplemental GMD event and the description in the white paper provide your recommendation and explanation.**
- 3. The SDT established an 85 A per phase screening criterion for determining which power transformers are required to be assessed for thermal impacts from a supplemental GMD event in Requirement R10. Justification for this threshold is provided in the revised Screening Criterion for Transformer Thermal Impact Assessment white paper. Do you agree with the proposed 85 A per phase screening criterion and the technical justification for this criterion that has been added to the white paper? If you do not agree, or if you agree but have comments or suggestions for the screening criterion and revisions to the white paper provide your recommendation and explanation.**
- 4. The SDT revised the Transformer Thermal Impact Assessment white paper to include the supplemental GMD event. Do you agree with the revisions to the white paper? If you do not agree, or if you agree but have comments or suggestions on the revisions to the white paper provide your recommendation and explanation.**
- 5. The SDT developed proposed Requirement R7 to address FERC directives in Order No. 830 for establishing Corrective Action Plan (CAP) deadlines associated with GMD Vulnerability Assessments (P. 101, 102). Do you agree with the proposed requirement? If you do not agree, or if you agree but have comments or suggestions for the proposed requirement provide your recommendation and explanation.**

- 6. The SDT developed Requirements R11 and R12 to address FERC directives in Order No. 830 for requiring responsible entities to collect GIC monitoring and magnetometer data (P. 88; P. 90-92). Do you agree with the proposed requirements? If you do not agree, or if you agree but have comments or suggestions for the proposed requirements provide your recommendation and explanation.**
- 7. Do you agree with the proposed Implementation Plan for TPL-007-2? If you do not agree, or if you agree but have comments or suggestions for the Implementation Plan provide your recommendation and explanation.**
- 8. Do you agree with the Violation Risk Factors (VRFs) and Violation Severity Levels (VSLs) for the requirements in proposed TPL-007-2? If you do not agree, or if you agree but have comments or suggestions for the VRFs and VSLs provide your recommendation and explanation.**
- 9. The SDT believes proposed TPL-007-2 provide entities with flexibility to meet the reliability objectives in the project Standards Authorization Request (SAR) in a cost effective manner. Do you agree? If you do not agree, or if you agree but have suggestions for improvement to enable additional cost effective approaches to meet the reliability objectives, please provide your recommendation and, if appropriate, technical justification.**
- 10. Provide any additional comments for the SDT to consider, if desired.**

Organization Name	Name	Segment(s)	Region	Group Name	Group Member Name	Group Member Organization	Group Member Segment(s)	Group Member Region
Brandon McCormick	Brandon McCormick		FRCC	FMPPA	Tim Beyrle	City of New Smyrna Beach Utilities Commission	4	FRCC
					Jim Howard	Lakeland Electric	5	FRCC
					Lynne Mila	City of Clewiston	4	FRCC
					Javier Cisneros	Fort Pierce Utilities Authority	3	FRCC
					Randy Hahn	Ocala Utility Services	3	FRCC
					Don Cuevas	Beaches Energy Services	1	FRCC
					Jeffrey Partington	Keys Energy Services	4	FRCC
					Tom Reedy	Florida Municipal Power Pool	6	FRCC
					Steven Lancaster	Beaches Energy Services	3	FRCC

					Mike Blough	Kissimmee Utility Authority	5	FRCC
					Chris Adkins	City of Leesburg	3	FRCC
					Ginny Beigel	City of Vero Beach	3	FRCC
ACES Power Marketing	Brian Van Gheem	6	NA - Not Applicable	ACES Standards Collaborators	Greg Froehling	Rayburn Country Electric Cooperative, Inc.	3	SPP RE
					Bob Solomon	Hoosier Energy Rural Electric Cooperative, Inc.	1	RF
					Ginger Mercier	Prairie Power, Inc.	1	SERC
					Shari Heino	Brazos Electric Power Cooperative, Inc.	1,5	Texas RE
					Mark Ringhausen	Old Dominion Electric Cooperative	4	SERC

					Tara Lightner	Sunflower Electric Power Corporation	1	SPP RE
					Ryan Strom	Buckeye Power, Inc.	4	RF
					Scott Brame	North Carolina Electric Membership Corporation	3,4,5	SERC
Colby Bellville	Colby Bellville		FRCC,RF,SERC	Duke Energy	Doug Hils	Duke Energy	1	RF
					Lee Schuster	Duke Energy	3	FRCC
					Dale Goodwine	Duke Energy	5	SERC
					Greg Cecil	Duke Energy	6	RF
MRO	Dana Klem	1,2,3,4,5,6	MRO	MRO NSRF	Joseph DePoorter	Madison Gas & Electric	3,4,5,6	MRO
					Larry Heckert	Alliant Energy	4	MRO
					Amy Casucelli	Xcel Energy	1,3,5,6	MRO
					Michael Brytowski	Great River Energy	1,3,5,6	MRO
					Jodi Jensen	Western Area Power Administration	1,6	MRO

					Kayleigh Wilkerson	Lincoln Electric System	1,3,5,6	MRO
					Mahmood Safi	Omaha Public Power District	1,3,5,6	MRO
					Brad Parret	Minnesota Powert	1,5	MRO
					Terry Harbour	MidAmerican Energy Company	1,3	MRO
					Tom Breene	Wisconsin Public Service Corporation	3,5,6	MRO
					Jeremy Voll	Basin Electric Power Cooperative	1	MRO
					Kevin Lyons	Central Iowa Power Cooperative	1	MRO
					Mike Morrow	Midcontinent ISO	2	MRO
Electric Reliability Council of Texas, Inc.	Elizabeth Axson	2		IRC Standards Review Committee	Elizabeth Axson	ERCOT	2	Texas RE
					Ben Li	IESO	2	NPCC
					Mark Holman	PJM	2	RF

					Greg Campoli	NYISO	2	NPCC
					Terry Blilke	Midcontinent ISO, Inc.	2	MRO
					Ali Miremadi	California ISO	2	WECC
					Matthew Goldberg	ISO NE	2	NPCC
					Charles Yeung	Southwest Power Pool, Inc. (RTO)	2	SPP RE
Lower Colorado River Authority	Michael Shaw	6		LCRA Compliance	Teresa Cantwell	LCRA	1	Texas RE
					Dixie Wells	LCRA	5	Texas RE
					Michael Shaw	LCRA	6	Texas RE
Manitoba Hydro	Mike Smith	1		Manitoba Hydro	Yuguang Xiao	Manitoba Hydro	5	MRO
					Karim Abdel-Hadi	Manitoba Hydro	3	MRO
					Blair Mukanik	Manitoba Hydro	6	MRO
					Mike Smith	Manitoba Hydro	1	MRO
Southern Company - Southern	Pamela Hunter	1,3,5,6	SERC	Southern Company	Katherine Prewitt	Southern Company Services, Inc.	1	SERC

Company Services, Inc.					R. Scott Moore	Alabama Power Company	3	SERC
					William D. Shultz	Southern Company Generation	5	SERC
					Jennifer G. Sykes	Southern Company Generation and Energy Marketing	6	SERC
Northeast Power Coordinating Council	Ruida Shu	1,2,3,4,5,6,7,8,9,10	NPCC	RSC no Hydro One, HQ and IESO	Guy Zito	Northeast Power Coordinating Council	NA - Not Applicable	NPCC
					Randy MacDonald	New Brunswick Power	2	NPCC
					Wayne Sipperly	New York Power Authority	4	NPCC
					Glen Smith	Entergy Services	4	NPCC
					Brian Robinson	Utility Services	5	NPCC



Bruce Metruck	New York Power Authority	6	NPCC
Alan Adamson	New York State Reliability Council	7	NPCC
Edward Bedder	Orange & Rockland Utilities	1	NPCC
David Burke	Orange & Rockland Utilities	3	NPCC
Michele Tondalo	UI	1	NPCC
Laura Mcleod	NB Power	1	NPCC
Michael Forte	Con Edison	1	NPCC
Kelly Silver	Con Edison	3	NPCC
Peter Yost	Con Edison	4	NPCC
Brian O'Boyle	Con Edison	5	NPCC
Michael Schiavone	National Grid	1	NPCC

					Michael Jones	National Grid	3	NPCC
					David Ramkalawan	Ontario Power Generation Inc.	5	NPCC
					Quintin Lee	Eversource Energy	1	NPCC
					Kathleen Goodman	ISO-NE	2	NPCC
					Greg Campoli	NYISO	2	NPCC
					Silvia Mitchell	NextEra Energy - Florida Power and Light Co.	6	NPCC
					Sean Bodkin	Dominion - Dominion Resources, Inc.	6	NPCC
Southwest Power Pool, Inc. (RTO)	Shannon Mickens	2	SPP RE	SPP Standards Review Group	Shannon Mickens	Southwest Power Pool Inc.	2	SPP RE
					Amy Casuscelli	Xcel Energy	1,3,5,6	SPP RE
					Louis Guidry	Cleco	1,3,5,6	SPP RE
					Don Schmit	Nebraska Public Power District	5	SPP RE

					Jamison Cawley	Nebraska Public Power District	1	SPP RE
					Scott Jordan	Southwest Power Pool	2	SPP RE
					Kevin Giles	Westar Energy	1	SPP RE
					Jonathan Hayes	Southwest Power Pool	2	SPP RE
					Allan George	Sunflower Electric Power Corporation	1	SPP RE
Santee Cooper	Shawn Abrams	1		Santee Cooper	Tom Abrams	Santee Cooper	1	SERC
					Rene' Free	Santee Cooper	1	SERC
					Chris Wagner	Santee Cooper	1	SERC

## Question 1

1. The SDT developed proposed Requirements R8 – R10 and the supplemental GMD event to address FERC concerns with the benchmark GMD event used in GMD Vulnerability Assessments. (Order No. 830 P.44, P.47-49, P.65). The requirements will obligate responsible entities to perform a supplemental GMD Vulnerability Assessment based on the supplemental GMD event that accounts for potential impacts of localized peak geoelectric fields. Do you agree with the proposed requirements? If you do not agree, or if you agree but have comments or suggestions for the proposed requirements provide your recommendation and explanation.

Thomas Foltz - AEP - 5

Answer No

Document Name

#### Comment

AEP is concerned by the potential duplication of efforts for any assets that are brought into scope by both the Benchmark and Supplemental Vulnerability Assessments (R6 and R10). While it may not be the drafting team's intent that multiple thermal impact assessments be conducted for the same assets, nor that two sets of suggested actions be developed to mitigate the impact of any GICs, the current draft does not make this explicitly clear. AEP requests that additional clarity be added so that duplicative efforts would not be necessary for any assets that are brought into scope under both the Benchmark and Supplemental Vulnerability Assessments. In general, the SDT should look for opportunities to minimize the potential duplication of work and evidence requirements throughout the drafted standard.

Likes 0

Dislikes 0

#### Response

Thank you for your comment. It is conceivable that two separate thermal assessments may need to be done for transformers that exceed both GIC thresholds: One for the benchmark event and one for the supplemental event. The distinction between the benchmark and supplemental thermal assessments is that the benchmark assessment may result in a Corrective Action Plan, but the supplemental assessment does not.

Mike Smith - Manitoba Hydro - 1, Group Name Manitoba Hydro

Answer No

Document Name

**Question 1**

**Comment**

It is not clear how complying with Requirements R8 to R10 will mitigate GMD risk to BES reliability. This proposal does not address the FERC concerns of developing a GMD benchmark not solely based on a spatially averaged magnetometer data. Manitoba Hydro (MH) believes that specifying a one methodology in the standard is not appropriate because of the diversity of the BES across the continent and different level of risk tolerances among the responsible entities. Instead of asking to follow a specific GMD Vulnerability Assessment methodology, MH would like to propose the SDT to consider providing an option in the standard where the responsible entities can develop their own GMD Assessment Methodology based on the technical knowledge obtained through the research work performed on GMD Vulnerability Assessments in their system.

In Manitoba, for example, NRCAN has calculated the 1/100 year geoelectric field to be roughly 5 V/km at the northernmost magnetometer site in Manitoba (Churchill) using specific model of the earth resistivity in Manitoba. NRCAN has done similar calculations for Alberta and has also found the field to be much lower than 8 V/km as well. Rather than spatial averaging, NRCAN used extreme value mathematics to calculate the fields.

Likes 0

Dislikes 0

**Response**

Thank you for your comment. The SDT is being responsive to the Standards Authorization Request (SAR). The existing standard already has a vulnerability assessment requirement that is approved and effective and subject to compliance by applicable registered entities. Any proposed revisions to this requirement should be addressed in a new SAR.

**Michelle Amarantos - APS - Arizona Public Service Co. - 1**

**Answer**

No

**Document Name**

**Comment**

AZPS agrees with the requirements as written, but has concerns regarding the inconsistent treatment of deadline or time-related requirements or sub-requirements in the Table of Compliance Elements. More specifically, both Requirement R8 and R9 contain 90 day deadlines for administrative activities. However, these requirements/sub-requirements are treated differently with respect to the violation

## Question 1

severity levels (VSLs). In particular, Requirement R8 treats the failure to timely provide/respond within 90 days as one element and does not increase the VSL based on the duration of the delay beyond the 90 day time period. Conversely, Requirement R9 ties the VSL directly to the duration of the delay beyond the 90 day time period. AZPS notes that the activities associated with the 90 day time periods are administrative in nature, e.g., providing a report or a response, and, therefore, will have a minimal (if any) impact on the reliability of the Bulk Electric System (BES). For this reason, AZPS recommends that the SDT conform Requirement R9 to the form provided in Requirement R8. Such revision will provide consistency and more accurately reflect the actual or potential impact on the BES.

Likes	0
-------	---

Dislikes	0
----------	---

## Response

Thank you for your comment. The timelines for the VSLs are consistent with the VSLs for Requirements R4 (benchmark) and R8 (supplemental) as is Requirements R5 and R9. Requirements R4 and R8 cover the days tardy as an element of the requirement and its subpart and Requirements R5 and R9 do not.

**Chantal Mazza - Hydro-Québec TransEnergie - 1,2 - NPCC**

Answer	No
--------	----

Document Name	
---------------	--

## Comment

Hydro-Quebec considers that because of the specificity of its network, (on a wide area, with long transmission lines and northern location) the benchmark event is sufficiently severe and covers the possible impact of the localized enhancement on our grid. These requirements burden the responsible entities to perform additional assessments that are both costly and uneffective.

Based on prior real measurements done on geomagnetic local disturbances in Abitibi (see reference below), we think that it would be preferable to wait for further analysis that takes into account real electric fields and current measures and not only magnetic measurements and calculated electric fields. Therefore adding a supplemental event on the already severe and pessimistic benchmark event should wait. Hydro Québec is currently in discussion with Natural Resources Canada to complete an analysis using Canadian magnetometer data in the province of Québec.

Hydro-Quebec acknowledges that the requirements address the FERC concerns.

**Question 1**

Reference: *A study of geoelectromagnetic disturbances in Quebec.* ([IEEE Transactions on Power Delivery](#) in 1998 and in 2000)<sup>1</sup>

Likes 0

Dislikes 0

**Response**

Thank you for your comment. The SDT is being responsive to the Standards Authorization Request (SAR) and FERC directives. The SDT appreciates Hydro Québec’s research in this area and how its findings might enhance the standard in the future.

**Nicolas Turcotte - Hydro-Québec TransEnergie - 1**

**Answer** No

**Document Name**

**Comment**

Hydro-Quebec considers that because of the specificity of its network, (on a wide area, with long transmission lines and northern location) the benchmark event is sufficiently severe and covers the possible impact of the localized enhancement on our grid. These requirements burden the responsible entities to perform additional assessments that are both Costly and ineffective.

Based on prior real measurements done on geomagnetic local disturbances in Abitibi (see reference below), we think that it would be preferable to wait for further analysis that takes into account real electric fields and current measures and not only magnetic measurements and calculated electric fields. Therefore adding a supplemental event on the already severe and pessimistic benchmark event should wait.

Hydro Québec is currently in discussion with Natural Resources Canada to complete an analysis using Canadian magnetometer data in the province of Québec.

Hydro-Quebec acknowledges that the requirements address the FERC concerns.

Reference: *A study of geoelectromagnetic disturbances in Quebec.* ([IEEE Transactions on Power Delivery](#) in 1998 and in 2000)<sup>2</sup>

Likes 0

<sup>11</sup> <http://ieeexplore.ieee.org/xpl/RecentIssue.jsp?punumber=61>

<sup>2</sup> <http://ieeexplore.ieee.org/xpl/RecentIssue.jsp?punumber=61>

## Question 1

Dislikes 0

## Response

Thank you for your comment. The SDT is being responsive to the Standards Authorization Request. The existing standard already has a vulnerability assessment requirement that is approved and effective and subject to compliance by applicable registered entities. The commenter is suggesting an alternative methodology to the existing standard which is outside the scope of the SDT and should be addressed in a new SAR.

Payam Farahbakhsh - Hydro One Networks, Inc. - 1

Answer

No

Document Name

## Comment

The intent of requirements R8 to R10 is not clear. It is understood that the intent is to address the directive in FERC Order No 830; however, it is not clear how complying with requirements 8-10 will mitigate GMD imposed risk to BES reliability.

Requirement R4 requires responsible entities to perform Benchmark GMD Vulnerability Assessments (based on a benchmark GMD event) to identify risk to BES reliability. Requirement R7 requires responsible entities to mitigate the identified risk by developing a corrective action plan.

The new requirements R8 to R10 are asking for additional assessments and evaluations to identify risk to BES reliability. The additional assessments required in R8 is arguably repeating what is required in R4 based on an amplified GMD event called supplemental GMD benchmark event.

It is arguable that performing the GMD vulnerability assessments based on the supplemental GMD benchmark event will result in identification of a higher risk to BES reliability in comparison with risk identified by performing GMD assessments using the GMD benchmark event currently in TPL-007-1.

Based on the current wording of the standard, the responsible entity is not required to consider the elevated risk (based on the supplemental GMD assessments) in their corrective action plans. Requirement 8.3 states:

*"If the analysis concludes there is Cascading caused by the supplemental GMD event described in Attachment 1, an evaluation of possible actions designed to reduce the likelihood or mitigate the consequences and adverse impacts of the event(s) shall be conducted."*



**Question 1**

The word “evaluation” suggests further assessments but not necessarily any further mitigations of risk. So the real question is why would responsible entities be required to perform a supplemental assessment? And how is this additional assessment designed to mitigate risk to BES reliability?

The Standard Drafting Team has not revised the GMD benchmark event definition rather they introduced a new supplemental GMD event to account for potential impacts of localized peak geoelectric field.

In paragraph 44, FERC Order No. 830 directed NERC to revise the GMD benchmark event definition so that the reference peak geoelectric field amplitude component is not solely based on spatially-averaged data. This approach will burden the responsible entities to perform additional assessments without a clear outcome.

We recommend that the Standard Drafting Team follow the results based standard development concept. The requirements should be focused on required actions or results (the "what") and not necessarily the methods by which to accomplish those actions or results (the "how").

Paragraph 65 in FERC Order No. 830 suggests that NERC could propose “some equally efficient and effective alternative”. An alternative approach is to move away from specifying a methodology as the only option to perform GMD assessments in the standard. Instead, create an option for the entities to develop their own GMD assessment methodology based on their own research of GMD risks to and impact on BES reliability.

Responsible entities across the continent have diverse systems, equipment, resources, and risk tolerance. Specifying a one approach fits-all does not seem to be appropriate.

The benchmark GMD event and the supplemental GMD event described in the whitepapers (and currently referenced within the standard requirements) can each be used to perform GMD assessments; however, the standard should not limit the entities to only use these prescribed GMD events. Instead, the standard should allow entities to perform GMD assessments based on alternative GMD events as justified by the responsible entities based on their own research and methodology.

Ultimately, whichever GMD assessment methodology the responsible entity chooses to use, the system-wide impact and transformer thermal impact should be assessed.

Likes 1	Hydro One Networks, Inc., 3, Malozewski Paul
Dislikes 0	

**Response**

## Question 1

Thank you for your comment. The SDT is being responsive to the Standards Authorization Request and FERC directives. The existing standard already has a vulnerability assessment requirement that is approved, and effective and subject to compliance by applicable registered entities. The supplemental assessment has been added to address local enhancements, but without the requirement of a Corrective Action Plan. Any proposed revisions to this requirement should be addressed in a new SAR. The Transformer Thermal Impact Assessment White Paper and Screening Criterion for Transformer Thermal Impact Assessment documents have provided the technical foundation and methodologies that can be used to conduct transformer temperature rise calculations for both the benchmark case and the supplemental case.

## Joel Robles - Omaha Public Power District - 1,3,5,6

Answer	No
--------	----

Document Name	
---------------	--

## Comment

. OPPD will be supporting MRO NSRF comments. Please note this on your ballot when you vote.

Likes	0
-------	---

Dislikes	0
----------	---

## Response

Thank you for supporting the MRO NSRF comments.

## David Ramkalawan - Ontario Power Generation Inc. - 5

Answer	No
--------	----

Document Name	
---------------	--

## Comment

OPG agrees that proposed Requirements R8 – R10 and the supplemental GMD event **attempts** to address FERC concerns with the benchmark GMD event used in GMD Vulnerability Assessments, however they fell short of mitigating GMD risk to the reliability of BES. Requirement R10 – “**10.3. Describe suggested actions** and supporting analysis to mitigate the impact of GICs, if any; ..” is just a good intention and cannot account for a Corrective Action Plan.

**Question 1**

Moreover we now have two type of GMD events the Benchmark and the Supplemental; OPG is of the opinion that they should be amalgamated in one GMD type of events (albeit this may require GMD benchmark event definition revision). OPG believes that Supplemental GMD event assessment will render the Benchmark GMD event assessment obsolete (based on the more stringent condition) and thus will be an unnecessary budgetary burden.

Only Requirement R4 based on the benchmark GMD event VA is leading to a CAP via R7, and this does not happen for the Supplemental GMD event VA based on the new R8 – R10

Likes 0

Dislikes 0

**Response**

The SDT is being responsive to the Standards Authorization Request. The existing standard already has a vulnerability assessment requirement that is approved, and effective and subject to compliance by applicable registered entities. The supplemental assessment has been added to address local enhancements, but without the requirement of a Corrective Action Plan. The comment is suggesting an alternative threshold or benchmark to the existing standard which is outside the scope of the SDT and should be addressed in a new SAR. The Transformer Thermal Impact Assessment White Paper and Screening Criterion for Transformer Thermal Impact Assessment documents have provided the technical foundation and methodologies that can be used to conduct transformer temperature rise calculations for both the benchmark case and the supplemental case.

**Marty Hostler - Northern California Power Agency - 5**

**Answer**

No

**Document Name**

**Comment**

NCPA disagrees with having to perform supplemental GMD assessments. If it is to be required, then there should be a TRF MVA threshold of 500 MVA or greater. NCPA also disagrees with having to provide any assessment to any registered entity, other than our TP or RC.

Likes 0

Dislikes 0

**Response**

## Question 1

The SDT is being responsive to the Standards Authorization Request and FERC directives. The existing standard already has a vulnerability assessment requirement that is approved, and effective and subject to compliance by applicable registered entities. The supplemental assessment has been added to address local enhancements, but without the requirement of a Corrective Action Plan. The comment is suggesting an alternative threshold or benchmark to the existing standard which is outside the scope of the SDT and should be addressed in a new SAR. The Transformer Thermal Impact Assessment White Paper and Screening Criterion for Transformer Thermal Impact Assessment documents have provided the technical foundation and methodologies that can be used to conduct transformer temperature rise calculations for both the benchmark case and the supplemental case. Providing the assessment to others has a reliability benefit.

**Dennis Sismaet - Northern California Power Agency - 6**

Answer

No

Document Name

**Comment**

NCPA disagrees with having to perform supplemental GMD assessments. If it is to be required, then there should be a TRF MVA threshold of 500 MVA or greater. NCPA also disagrees with having to provide any assessment to any registered entity, other than our TP or RC.

Likes 0

Dislikes 0

**Response**

The SDT is being responsive to the Standards Authorization Request. The existing standard already has a vulnerability assessment requirement that is approved, and effective and subject to compliance by applicable registered entities. The supplemental assessment has been added to address local enhancements, but without the requirement of a Corrective Action Plan. The comment is suggesting an alternative threshold or benchmark to the existing standard which is outside the scope of the SDT and should be addressed in a new SAR. The Transformer Thermal Impact Assessment White Paper and Screening Criterion for Transformer Thermal Impact Assessment documents have provided the technical foundation and methodologies that can be used to conduct transformer temperature rise calculations for both the benchmark case and the supplemental case.

Since GMD events are likely to be wide-area, it is necessary to share the information with other entities.

**Question 1**

**William Harris - Foundation for Resilient Societies - 8**

<b>Answer</b>	No
<b>Document Name</b>	Foundation for Resilient Societies on NERC Project 2013 081117_Submitted.docx

**Comment**

Resilient Societies has concerns that the relevant classes of GMD events are not fully addressed; that the 75 amps per phase threshold is imprudent and not science based, and that a complementary effort is needed to test equipment under load and to test long replacement time equipment types to destruction. See attached Comments.

Likes 0

Dislikes 0

**Response**

Thank you for your comment. Please see the responses at the end of this document referencing the attached comments.

**Randy Buswell - VELCO -Vermont Electric Power Company, Inc. - 1**

<b>Answer</b>	Yes
<b>Document Name</b>	

**Comment**

This will place considerably more of a burden on the entities performing the GMD Vulnerability Assessments with the need to perform another whole assessment, but also, presumably, with the need to collect the data needed for creation of a "localized peak geoelectric field".

Likes 0

Dislikes 0

**Response**

Thank you for your comment. The supplemental assessment is additional work, but it is necessary to account for the impacts of local enhancements. No additional system data are required.

**Joe O'Brien - NiSource - Northern Indiana Public Service Co. - 6**

## Question 1

<b>Answer</b>	Yes
---------------	-----

<b>Document Name</b>	
----------------------	--

**Comment**

NIPSCO agrees that supplemental GMD vulnerability assessment accounts for potential impact of localized peak geo-electric fields. However, instead of its own set of requirements, we feel it is appropriate to consider the supplemental GMD vulnerability assessment as a sensitivity case to the benchmark GMD vulnerability assessment. In addition, Requirement R8 requires conducting analysis for any potential cascading due to supplemental GMD event. However, R4 (Benchmark GMD vulnerability assessment) does not require such potential cascading evaluation. A uniformity in requirement would be desirable.

Likes	0
-------	---

Dislikes	0
----------	---

**Response**

Thank you for your comment. Requirement R8 focuses on Cascading because the supplemental event is a more extreme event than the benchmark event.

**Lauren Price - American Transmission Company, LLC - 1**

<b>Answer</b>	Yes
---------------	-----

<b>Document Name</b>	
----------------------	--

**Comment**

The supplemental GMD vulnerability assessment does not appear to be an overly onerous burden on the responsible entities as it is an enhancement based on the already required benchmark assessment. The potential impacts of localized peaks are necessary to evaluate due to the short time constant of the windings and structures affected by stray fields resulting from part cycle saturation.

Likes	0
-------	---

Dislikes	0
----------	---

**Response**

**Question 1**

Thank you for your comment. The SDT agrees that the impacts of local enhancements need to be considered in network analysis and transformer assessment.

**Aaron Cavanaugh - Bonneville Power Administration - 1,3,5,6 - WECC**

**Answer** Yes

**Document Name**

**Comment**

For R8.4 and R9 and their associated measures, BPA proposes rather than “shall be provided/shall provide” that the wording be changed to “shall make available.” For the western interconnection, a separate entity may be collecting interconnection-wide data.

Likes 0

Dislikes 0

**Response**

Thank you for your comment. The SDT does not agree with revising the language as it would affect the responsibilities as proposed in the standard.

**Michael Shaw - Lower Colorado River Authority - 6, Group Name LCRA Compliance**

**Answer** Yes

**Document Name**

**Comment**

The ability to perform a system-wide study at the supplemental GMD level is helpful in cases where software cannot support a localized event. It is not overly clear why 85 A is acceptable for the supplemental assessment vs. 75 A for the benchmark assessment. The distinction between the two should be made clearer (e.g. “85 A is acceptable even as a higher value because the local (higher magnitude) field is assumed to be applied for a shorter duration”)

Likes 0

Dislikes 0

## Question 1

## Response

Thank you for your comment. From a hot spot temperature rise point of view, 75 A/phase and 85 A/phase are equivalent. A more detailed explanation has been added to the Screening Criterion for Transformer Thermal Impact Assessment white paper above Table 2.

**sean erickson - Western Area Power Administration - 1**

**Answer**

Yes

**Document Name**

**Comment**

[TPLTF](#)<sup>3</sup> Discussion: The group agrees with the SDT approach to addressing FERC Order No. 830 Paragraph 44. In effect, the SDT has specified an extreme value for geoelectric field, called the supplemental GMD event, intended to represent a locally-enhanced geoelectric field experienced by a limited geographic area. In other words, the SDT has proposed a means by which Planning Coordinators and Transmission Planners can approximate a non-geospatially-averaged peak geoelectric field, thus meeting the intent of the FERC Order No. 830 directive. While determining peak geoelectric field amplitudes not based solely on spatially-averaged data is a significant challenge to meeting the FERC directive, primarily because of the lack of North American data, as well as analytical tools available to Planning Coordinators and Transmission Planners, the group believes the SDT has found a workable approach.

The group would like to note that it will be non-trivial to apply the localized peak geoelectric field in the supplemental GMD event to a spatially-limited area, described in the proposed TPL-007-2 Attachment 1, given available software tools and available personnel resources. This will be especially pronounced for Planning Coordinators and Transmission Planners with large geographical footprints. Many planning entities will be forced to apply the supplemental peak geoelectric field over their entire area, in effect simply studying a higher magnitude benchmark GMD event. While the group believes this is prominently conservative, as stated above, we understand and support the SDT approach to this directive. It is likewise noted that the definition of a spatially-limited area is absent in the materials published by the SDT, but this vagary supports better analytical flexibility for Planning Coordinators and Transmission Planners and should not be defined in the draft standard.

Likes 0

<sup>3</sup> TPLTF document is found at the end of this document in Attachment 1.



Question 1

Dislikes 0

**Response**

Thank you for your comment. The comment is an excellent summary of the intent of the SDT relative to accounting for the impacts of local enhancements. The SDT provides considerable flexibility to the planners as to how to reflect the supplemental event into their assessments. The SDT believes that this is especially appropriate for the planners who are dealing with very large systems.

**Neil Swearingen - Salt River Project - 1,3,5,6 - WECC**

**Answer** Yes

**Document Name**

**Comment**

SRP supports the response provided by WAPA on behalf of [TPLTF](#)<sup>4</sup> for question 1

Likes 0

Dislikes 0

**Response**

Thank you for your comment. The comment is an excellent summary of the intent of the SDT relative to accounting for the impacts of local enhancements. The SDT provides considerable flexibility to the planners as to how to reflect the supplemental event into their assessments. The SDT believes that this is especially appropriate for the planners who are dealing with very large systems.

**Larisa Loyferman - CenterPoint Energy Houston Electric, LLC - 1 - Texas RE**

**Answer** Yes

**Document Name**

**Comment**

<sup>4</sup> TPLTF document is found at the end of this document in Attachment 1.

## Question 1

CenterPoint Energy Houston Electric, LLC (“CenterPoint Energy”) commends the efforts of the SDT and believes Requirements R8 – R10 address FERC concerns with the benchmark GMD event used in GMD Vulnerability Assessments. Additionally, CenterPoint Energy agrees that the supplemental GMD Vulnerability Assessment accounts for potential impact of localized peak geo-electric fields”.

CenterPoint Energy shares AEP’s concern with the potential duplication of efforts for any assets that are brought into scope by both the Benchmark and Supplemental Vulnerability Assessments (R6 and R10). While it may not be the drafting team’s intent that multiple thermal impact assessments be conducted for the same assets, nor that two sets of suggested actions be developed to mitigate the impact of any GICs, the current draft does not make this explicitly clear. CenterPoint Energy supports AEP’s request that additional clarity be added so that duplicative efforts would not be necessary for any assets that are brought into scope under both the Benchmark and Supplemental Vulnerability Assessments.

Likes	0
-------	---

Dislikes	0
----------	---

## Response

The SDT is being responsive to the Standards Authorization Request. The existing standard already has a vulnerability assessment requirement that is approved, and effective and subject to compliance by applicable registered entities. The supplemental assessment has been added to address local enhancements, but without the requirement of a Corrective Action Plan. The comment is suggesting an alternative threshold or benchmark to the existing standard which is outside the scope of the SDT and should be addressed in a new SAR. The Transformer Thermal Impact Assessment White Paper and Screening Criterion for Transformer Thermal Impact Assessment documents have provided the technical foundation and methodologies that can be used to conduct transformer temperature rise calculations for both the benchmark case and the supplemental case.

**Stephanie Burns - Stephanie Burns On Behalf of: Michael Moltane, International Transmission Company Holdings Corporation, 1; - Stephanie Burns**

Answer	Yes
--------	-----

Document Name	
---------------	--

## Comment

While disagreeing with the original FERC determination requiring the modification to the benchmark GMD event so that the assessments are not based solely on spatially-averaged data using the determined reference 8 V/km peak geoelectric field amplitude, we do agree on the

## Question 1

SDT's proposal of conducting a supplemental assessment using 12 V/km as the reference non-spatially averaged peak geoelectric field amplitude (as opposed to using the alternative 20 V/km non-spatially averaged peak value noted by FERC in the GMD Interim Report which would have overestimated the severity of a 1-in-100 year GMD event ).

Likes 0

Dislikes 0

## Response

Thank you for your comment.

**Shannon Mickens - Southwest Power Pool, Inc. (RTO) - 2 - SPP RE, Group Name** SPP Standards Review Group

Answer

Yes

Document Name

## Comment

The SPP Standards Review Group agrees with the SDT approach to addressing FERC Order No. 830 Paragraph 44. In effect, the SDT has specified an extreme value for geoelectric field, called the supplemental GMD event, intended to represent a locally-enhanced geoelectric field experienced by a limited geographic area. In other words, the SDT has proposed a means by which Planning Coordinators and Transmission Planners can approximate a non-geospatially-averaged peak geoelectric field, thus meeting the intent of the FERC Order No. 830 directive. While determining peak geoelectric field amplitudes not based solely on spatially-averaged data is a significant challenge to meeting the FERC directive, primarily because of the lack of North American data, as well as analytical tools available to Planning Coordinators and Transmission Planners, the group believes the SDT has found a workable approach.

The group would like to note that it will be non-trivial to apply the localized peak geoelectric field in the supplemental GMD event to a spatially-limited area, described in the proposed TPL-007-2

Attachment 1, given available software tools and available personnel resources. This will be especially pronounced for Planning Coordinators and Transmission Planners with large geographical footprints. Many planning entities will be forced to apply the supplemental peak geoelectric field over their entire area, in effect simply studying a higher magnitude benchmark GMD event. While the group believes this is prominently conservative, as stated above, we understand and support the SDT approach to this directive. It is likewise noted that the definition of a spatially-limited area is absent in the materials published by the SDT, but this vagary supports better analytical flexibility for Planning Coordinators and Transmission Planners and should not be defined in the draft standard.

Question 1

Likes 0

Dislikes 0

**Response**

Thank you for your comment. The comment is an excellent summary of the intent of the SDT relative to accounting for the impacts of local enhancements. The SDT provides considerable flexibility to the planners as to how to reflect the supplemental event into their assessments. The SDT believes that this is especially appropriate for the planners who are dealing with very large systems.

**Chris Scanlon - Exelon - 1**

**Answer**

Yes

**Document Name**

**Comment**

See comment to Q 3.

Likes 0

Dislikes 0

**Response**

**RoLynda Shumpert - SCANA - South Carolina Electric and Gas Co. - 1,3,5,6 - SERC**

**Answer**

Yes

**Document Name**

**Comment**

Likes 0

Dislikes 0

Question 1

Response

Ann Ivanc - FirstEnergy - FirstEnergy Solutions - 6

Answer Yes

Document Name

Comment

Likes 0

Dislikes 0

Response

Daniel Grinkevich - Con Ed - Consolidated Edison Co. of New York - 1

Answer Yes

Document Name

Comment

Likes 0

Dislikes 0

Response

Robert Blackney - Edison International - Southern California Edison Company - 1,3,5,6 - WECC

Answer Yes

Question 1

Document Name

Comment

Likes 0

Dislikes 0

Response

Gerry Huitt - Xcel Energy, Inc. - 5

Answer

Yes

Document Name

Comment

Likes 0

Dislikes 0

Response

Laura Nelson - IDACORP - Idaho Power Company - 1

Answer

Yes

Document Name

Comment

Likes 0

Question 1	
Dislikes	0
<b>Response</b>	
Dana Klem - MRO - 1,2,3,4,5,6 - MRO, Group Name MRO NSRF	
Answer	Yes
Document Name	
<b>Comment</b>	
Likes	0
Dislikes	0
<b>Response</b>	
Karie Barczak - DTE Energy - Detroit Edison Company - 3	
Answer	Yes
Document Name	
<b>Comment</b>	
Likes	0
Dislikes	0
<b>Response</b>	
Laurie Williams - PNM Resources - Public Service Company of New Mexico - 1	

Question 1

Answer	Yes
Document Name	
Comment	
Likes 0	
Dislikes 0	
Response	
Joshua Eason - Joshua Eason On Behalf of: Michael Puscas, ISO New England, Inc., 2; - Joshua Eason	
Answer	Yes
Document Name	
Comment	
Likes 0	
Dislikes 0	
Response	
Eric Shaw - Eric Shaw On Behalf of: Lee Maurer, Oncor Electric Delivery, 1; - Eric Shaw	
Answer	Yes
Document Name	
Comment	



Question 1	
Likes 0	
Dislikes 0	
<b>Response</b>	
Jeffrey Watkins - Jeffrey Watkins On Behalf of: Eric Schwarzrock, Berkshire Hathaway - NV Energy, 5; - Jeffrey Watkins	
Answer	Yes
Document Name	
<b>Comment</b>	
Likes 0	
Dislikes 0	
<b>Response</b>	
Colby Bellville - Colby Bellville On Behalf of: Dale Goodwine, Duke Energy , 6, 5, 3, 1; - Colby Bellville, Group Name Duke Energy	
Answer	Yes
Document Name	
<b>Comment</b>	
Likes 0	
Dislikes 0	
<b>Response</b>	

Question 1

**Glen Farmer - Avista - Avista Corporation - 5**

Answer Yes

Document Name

Comment

Likes 0

Dislikes 0

Response

**Donald Lock - Talen Generation, LLC - 5**

Answer Yes

Document Name

Comment

Likes 0

Dislikes 0

Response

**Douglas Webb - Douglas Webb On Behalf of: Chris Bridges, Great Plains Energy - Kansas City Power and Light Co., 3, 6, 5, 1; Harold Wyble, Great Plains Energy - Kansas City Power and Light Co., 3, 6, 5, 1; James McBee, Great Plains Energy - Kansas City Power and Light Co., 3, 6, 5, 1; Jessica Tucker, Great Plains Energy - Kansas City Power and Light Co., 3, 6, 5, 1; - Douglas Webb**

Answer Yes

Question 1

Document Name

Comment

Likes 0

Dislikes 0

Response

Pamela Hunter - Southern Company - Southern Company Services, Inc. - 1,3,5,6 - SERC, Group Name Southern Company

Answer

Yes

Document Name

Comment

Likes 0

Dislikes 0

Response

Quintin Lee - Eversource Energy - 1

Answer

Yes

Document Name

Comment

Likes 0

Question 1

Dislikes 0

Response

Ruida Shu - Northeast Power Coordinating Council - 1,2,3,4,5,6,7,8,9,10 - NPCC, Group Name RSC no Hydro One, HQ and IESO

Answer Yes

Document Name

Comment

Likes 0

Dislikes 0

Response

Brian Van Gheem - ACES Power Marketing - 6 - NA - Not Applicable, Group Name ACES Standards Collaborators

Answer Yes

Document Name

Comment

Likes 0

Dislikes 0

Response

James Anderson - CMS Energy - Consumers Energy Company - 1,3,4,5

Question 1	
Answer	Yes
Document Name	
Comment	
Likes 0	
Dislikes 0	
Response	
<b>Michael Buyce - City Utilities of Springfield, Missouri - 1</b>	
Answer	Yes
Document Name	
Comment	
Likes 0	
Dislikes 0	
Response	
<b>Elizabeth Axson - Electric Reliability Council of Texas, Inc. - 2, Group Name IRC Standards Review Committee</b>	
Answer	Yes
Document Name	
Comment	

Question 1

Likes 0

Dislikes 0

Response

Sergio Banuelos - Tri-State G and T Association, Inc. - 1,3,5 - MRO,WECC

Answer Yes

Document Name

Comment

Likes 0

Dislikes 0

Response

Terry Harbour - Berkshire Hathaway Energy - MidAmerican Energy Co. - 1

Answer Yes

Document Name

Comment

Likes 0

Dislikes 0

Response

**Question 1**

**Sarah Gasienica - NiSource - Northern Indiana Public Service Co. - 5**

**Answer**

**Document Name**

**Comment**

Please see comments of Joesph N. O'Brien.

Likes 0

Dislikes 0

**Response**

**Romel Aquino - Edison International - Southern California Edison Company - 3**

**Answer**

**Document Name**

**Comment**

Please refer to comments submitted by Robert Blackney on behalf of Southern California Edison.

Likes 0

Dislikes 0

**Response**

No comments were submitted.

**Kenya Streeter - Edison International - Southern California Edison Company - 6**

**Answer**

**Document Name**

**Comment**

**Question 1**

Please refer to comments submitted by Robert Blackney on behalf of Southern California Edison.

Likes 0

Dislikes 0

**Response**

No comments were submitted.

**Rachel Coyne - Texas Reliability Entity, Inc. - 10**

**Answer**

**Document Name**

**Comment**

Texas RE does not have comments on this question.

Likes 0

Dislikes 0

**Response**

**Thomas Rafferty - Edison International - Southern California Edison Company - 5**

**Answer**

**Document Name**

**Comment**

Please refer to comments submitted by Robert Blackney on behalf of Southern California Edison

Likes 0

Dislikes 0

**Response**



## Question 1

No comments were submitted.

**Richard Vine - California ISO - 2**

**Answer**

**Document Name**

**Comment**

The California ISO supports the joint comments of the ISO/RTO Standards Review Committee

Likes 0

Dislikes 0

**Response**

Thank you for supporting the comments of the IRC Standards Review Committee (i.e., ISO/RTO Standards Review Committee).

## Question 2

2. The SDT developed the *Supplemental GMD Event Description* white paper to provide technical justification for the supplemental GMD event. The purpose of the supplemental GMD event description is to provide a defined event for assessing system performance for a GMD event which includes a local enhancement of the geomagnetic field. Do you agree with the proposed supplemental GMD event and the description in the white paper? If you do not agree, or if you agree but have comments or suggestions for the supplemental GMD event and the description in the white paper provide your recommendation and explanation.

**William Harris - Foundation for Resilient Societies - 8**

Answer No

Document Name

Comment

This is duplicative, but worse, both thresholds are likely to be above actual thresholds at which transformers catch fire, explode, or both.

Likes 0

Dislikes 0

Response

Thank you for your comment. Different screening thresholds were selected because benchmark and supplemental benchmark waveforms are different and their effects on healthy transformers are different for the same peak current. The temperature thresholds are consistent, i.e., the thermal effects on a transformer are characterized by peak temperatures.

**Dennis Sismaet - Northern California Power Agency - 6**

Answer No

Document Name

Comment

Increased costs do not justify the low, if any, reliability benefits.

Likes 0

Question 2

Dislikes 0

**Response**

Thank you for your comment. In the development of the TPL-007-2: Transmission System Planned Performance for Geomagnetic Disturbance Events standard with supplemental GMD event, the SDT is being responsive to the Standards Authorization Request. The consensus of the SDT is that the supplemental GMD Vulnerability Assessment provides a reliability benefit.

**Marty Hostler - Northern California Power Agency - 5**

**Answer** No

**Document Name**

**Comment**

Increased costs do not justify the low, if any, reliability benefits.

Likes 0

Dislikes 0

**Response**

Thank you for your comment. The Transformer Thermal Impact Assessment White Paper and Screening Criterion for Transformer Thermal Impact Assessment documents have provided the technical foundation and methodologies that can be used to conduct transformer temperature rise calculations for both the benchmark case and the supplemental case.

**Pamela Hunter - Southern Company - Southern Company Services, Inc. - 1,3,5,6 - SERC, Group Name Southern Company**

**Answer** No

**Document Name**

**Comment**

1. Paragraph 2, page 12 of the Supplemental GMD Event Description White Paper – the Drafting Team briefly discusses that the geographic area of the local enhancement is on the order of 100 km in N-S (latitude) and on the order of 500 km E-W (longitude). We

**Question 2**

recommend the SDT to provide additional information on the selection of ‘on the order of 500 km’ for longitudinal width. It is not clear why and how a width of 500 km(s) was selected. Why **not** consider a **longitudinal width** on the order of 100 km?

2. Figure II-1, page 17 – we recommend the Drafting Team to include a legend that clearly shows what each line means. This figure shows numerous lines (e.g., vertical, horizontal, etc.) that can lead to confusion.
3. Equation II.3, page 18, is missing the equal ‘=’ sign (E<sub>peak</sub> = ...)

Likes 0

Dislikes 0

**Response**

Thank you for your comment.

1. The geographic dimensions of local enhancements are based on a very limited set of events; therefore, flexibility is provided in the requirements in how to apply the dimensions in the analysis. A minor change was made in the reference to Figure II-1 in the Supplemental GMD Event Description document.
2. Correction made to the Supplemental GMD Event Description document.

**Joshua Eason - Joshua Eason On Behalf of: Michael Puscas, ISO New England, Inc., 2; - Joshua Eason**

Answer

No

Document Name

**Comment**

While ISO-NE supports the supplemental event, it believes that the probability of the event occurring in the lower 48 state portion of the United States is far less than once in one hundred years. The magnitude of enhancement is based on measurements from the IMAGE magnetometer stations which are located in northern Europe, rather than observations in the United States. Also, the four examples in the Supplemental Geomagnetic Event Description in Figures I-4,5,6 & 7 all occur in far northern latitudes and it is not clear that these events will occur in more southern latitudes.

Likes 0

Dislikes 0

**Response**

**Question 2**

Thank you for your comment. The IMAGE dataset is the most complete and comprehensive data available and is therefore the best data source available to support the development of the standard.

Although the four events mentioned in the Supplemental Geomagnetic Event Description document all occurred in northern latitudes, there is no evidence that the local enhancement effect only occurs in high latitudes.

**Nicolas Turcotte - Hydro-Québec TransEnergie - 1**

**Answer** No

**Document Name**

**Comment**

see comments to Question 1.

Likes 0

Dislikes 0

**Response**

Thank you for your comment. See response in Question 1.

**Chantal Mazza - Hydro-Québec TransEnergie - 1,2 - NPCC**

**Answer** No

**Document Name**

**Comment**

See comments to Question 1.

Likes 0

Dislikes 0

**Response**

Thank you for your comment. See response in Question 1.

## Question 2

**Mike Smith - Manitoba Hydro - 1, Group Name** Manitoba Hydro

**Answer** No

**Document Name**

**Comment**

We think that we are still at the infancy of understanding the nature and mechanism of these local enhancements. The Geophysics need more time to study this phenomenon and figure out how to simulate it in our GIC Simulator.

Are the current state of the art assessment tools capable of modeling a “local” enhancement? Given the tools limitations, Transmission Planners will likely model the supplemental GMD event as a uniform field over the entire assessment area. It is not clear whether this is acceptable or whether this stress transformers in a similar way as a non-uniform field analysis.

Likes 0

Dislikes 0

**Response**

Thank you for your comment. The TPL-007-2 does not restrict the technically justified methodology for the industry to perform the local enhancement GMD event assessment due to the evolving understanding of local enhancements.

**sean erickson - Western Area Power Administration - 1**

**Answer** No

**Document Name**

**Comment**

[TPLTF](#)<sup>5</sup> Discussion: The group recognizes that there are multiple methods to approach revisions to the benchmark GMD event definition so that the reference peak geoelectric field amplitude component is not based solely on spatially-averaged data (FERC Order No. 830 Paragraph 44). However, given a wide diversity in available data, analytical tools, and personnel expertise, the group believes that the SDT has found a

<sup>5</sup> TPLTF document is found at the end of this document in Attachment 1.

## Question 2

practical approach to meeting the objective of the FERC directive. Moreover, the *Supplemental GMD Event Description* white paper presents a reasoned justification for the use of the geoelectric field amplitude of 12 V/km.

The group recommends that the SDT consider a less ambiguous name for the Supplemental GMD Event; the group believes *Extreme Value GMD Event* would be more appropriate for the following reasons:

{C}a. {C}Implies a closer relationship to the extreme events of TPL-001-4 for which Planning Coordinators and Transmission Planners are familiar.

{C}b. {C}Is better aligned with the extreme value statistical analysis that was conducted to produce the subject reference peak geoelectric field amplitude.

{C}c. {C}Indicates a measure of how rare the extreme value for the 1-in-100 year peak geoelectric field amplitude may be, based upon the 95% confidence interval of the extreme value.

While the group agrees that the application of extreme value statistical methods presented in the *Supplemental GMD Event Description* white paper is sound, three clarifying statements should be made in the white paper. Firstly, in short, the group agrees that by using the 23 years of daily maximum geoelectric field amplitudes from IMAGE magnetometers, a proxy of higher magnitude events can be characterized. It is noted that the southernmost magnetometer in the IMAGE chain resides in Suwałki, Poland at 54.01°N, whose geographic latitude places it roughly 500 miles north of Quebec. Given that geoelectric field is highly correlated with geomagnetic latitude rather than geographic latitude, the IMAGE data should still be referred to as a loose approximation for estimated North American geoelectric field magnitudes (Suwałki, Poland geomagnetic dipole latitude 52°N, Quebec geomagnetic dipole latitude 56°N). In other words, the group believes it is appropriate to qualify that the extreme value analysis performed in the white paper is based upon maximum data points obtained from an array of northern geomagnetically-biased latitudes, further inflated by using the high earth conductivity of Quebec. Secondly, it is well known that coastal geological conditions can lead to locally-enhanced geoelectric fields, not observed in regions more distant from the coast. Given that nearly all of the IMAGE chain magnetometers reside within 100 miles of the northern Atlantic Ocean or Baltic Sea coasts, it is reasonable to conclude that the geoelectric field amplitudes derived from the corresponding IMAGE data may have suffered from geoelectric field enhancement along conductivity boundaries. With respect to serving as a proxy for mainland North American peak geoelectric field amplitude, the SDT should consider further qualifying the appropriateness of the IMAGE data which served as the foundation of the extreme value analysis. Finally, the group agrees that the use of more resolute point over threshold (POT) methods was indicated over generalized extreme value (GEV). For clarity, however, it should be emphasized that the geoelectric field amplitude of 12 V/km represents the *extreme value* of the upper limit of the 95 percent confidence interval for a 100-year return interval. In other words, the statistical significance of the extreme value confidence interval is not equivalent to the statistic expressed by the confidence interval for the data set consisting of 23 years

## Question 2

of all sampled geoelectric field amplitudes (not shown). Each of these considerations, if addressed, can strengthen the conclusions of the white paper by emphasizing its conservative approach.

Likes 0

Dislikes 0

## Response

Thank you for supporting the [SPP TPLTF](#) comments<sup>6</sup> on the TPL-007-2 standard. The IMAGE dataset is the most complete and comprehensive data available and is therefore the best data source available to support the development of the standard.

Although the four events mentioned in the Supplemental Geomagnetic Event Description document all occurred in northern latitudes, there is no evidence that the local enhancement effect only occurs in high latitudes. Based on the past experiences with the IMAGE data, it is not expected that the coastal effect has a significant effect on the geomagnetic fields that were used in the extreme value analysis.

**Elizabeth Axson - Electric Reliability Council of Texas, Inc. - 2, Group Name** IRC Standards Review Committee

**Answer** Yes

**Document Name**

## Comment

While IRC supports the supplemental event description, it believes that the probability of this event occurring in the lower 48 state portion of the United States is far less than once in one hundred years. The magnitude of enhancement is based on measurements from the IMAGE magnetometer stations which are located in northern Europe, rather than observations in the United States. Also, the four examples in the Supplemental Geomagnetic Event Description in Figures I-4, 5, 6 & 7 all occur in far northern latitudes and it is not clear that these events will occur in more southern latitudes.

Likes 0

Dislikes 0

<sup>6</sup> TPLTF document is found at the end of this document in Attachment 1.



## Question 2

## Response

Thank you for your comment. The IMAGE dataset is the most complete and comprehensive data available and is therefore the best data source available to support the development of the standard.

Although the four events mentioned in the Supplemental Geomagnetic Event Description document all occurred in northern latitudes, there is no evidence that the local enhancement effect only occurs in high latitudes.

**Shannon Mickens - Southwest Power Pool, Inc. (RTO) - 2 - SPP RE, Group Name** SPP Standards Review Group

<b>Answer</b>	Yes
---------------	-----

<b>Document Name</b>	
----------------------	--

## Comment

The SPP Standards Review Group recognizes that there are multiple methods to approach revisions to the benchmark GMD event definition so that the reference peak geoelectric field amplitude component is not based solely on spatially-averaged data (FERC Order No. 830 Paragraph 44). However, given a wide diversity in available data, analytical tools, and personnel expertise, the group believes that the SDT has found a practical approach to meeting the objective of the FERC directive. Moreover, the Supplemental GMD Event Description white paper presents a reasoned justification for the use of the geoelectric field amplitude of 12 V/km.

We recommend that the SDT consider a less ambiguous name for the Supplemental GMD Event; the group believes Extreme Value GMD Event would be more appropriate for the following reasons:

1. Implies a closer relationship to the extreme events of TPL-001-4 for which Planning Coordinators and Transmission Planners are familiar.
2. Is better aligned with the extreme value statistical analysis that was conducted to produce the subject reference peak geoelectric field amplitude.
3. Indicates a measure of how rare the extreme value for the 1-in-100 year peak geoelectric field amplitude may be, based upon the 95% confidence interval of the extreme value.

While we agree that the application of extreme value statistical methods presented in the Supplemental GMD Event Description white paper is sound, three clarifying statements should be made in the white paper. Firstly, in short, the group agrees that by using the 23 years of daily maximum geoelectric field amplitudes from IMAGE magnetometers, a proxy of higher magnitude events can be characterized. It is noted that the southernmost magnetometer in the IMAGE chain resides in Suwałki, Poland at 54.01°N, whose geographic latitude places it roughly 500 miles north of Quebec. Given that geoelectric field is highly correlated with geomagnetic latitude rather than geographic latitude, the IMAGE

### Question 2

data should still be referred to as a loose approximation for estimated North American geoelectric field magnitudes (Suwałki, Poland geomagnetic dipole latitude 52°N, Quebec geomagnetic dipole latitude 56°N). In other words, the group believes it is appropriate to qualify that the extreme value analysis performed in the white paper is based upon maximum data points obtained from an array of northern geomagnetically-biased latitudes, further inflated by using the high earth conductivity of Quebec. Secondly, it is well known that coastal geological conditions can lead to locally-enhanced geoelectric fields, not observed in regions more distant from the coast. Given that nearly all of the IMAGE chain magnetometers reside within 100 miles of the northern Atlantic Ocean or Baltic Sea coasts, it is reasonable to conclude that the geoelectric field amplitudes derived from the corresponding IMAGE data may have suffered from geoelectric field enhancement along conductivity boundaries. With respect to serving as a proxy for mainland North American peak geoelectric field amplitude, the SDT should consider further qualifying the appropriateness of the IMAGE data which served as the foundation of the extreme value analysis. Finally, the group agrees that the use of more resolute point over threshold (POT) methods was indicated over generalized extreme value (GEV). For clarity, however, it should be emphasized that the geoelectric field amplitude of 12 V/km represents the extreme value of the upper limit of the 95 percent confidence interval for a 100-year return interval. In other words, the statistical significance of the extreme value confidence interval is not equivalent to the statistic expressed by the confidence interval for the data set consisting of 23 years of all sampled geoelectric field amplitudes (not shown). Each of these considerations, if addressed, can strengthen the conclusions of the white paper by emphasizing its conservative approach.

Likes 0

Dislikes 0

### Response

Thank you for supporting the [SPP TPLTF](#) comments<sup>7</sup> on the TPL-007-2 standard. The IMAGE dataset is the most complete and comprehensive data available and is therefore the best data source available to support the development of the standard.

Although the four events mentioned in the Supplemental Geomagnetic Event Description document all occurred in northern latitudes, there is no evidence that the local enhancement effect only occurs in high latitudes. Based on the past experiences with the IMAGE data, it is not expected that the coastal effect has a significant effect on the geomagnetic fields that were used in the extreme value analysis.

<sup>7</sup> TPLTF document is found at the end of this document in Attachment 1.

## Question 2

**Stephanie Burns - Stephanie Burns On Behalf of: Michael Moltane, International Transmission Company Holdings Corporation, 1; - Stephanie Burns**

**Answer** Yes

**Document Name**

**Comment**

The supplemental GMD event definition was determined through statistical analysis of available geomagnetic field data and corresponding calculations. The same data set and similar techniques were used in defining the benchmark GMD event with the exception that the supplemental definition was based on observations at each individual station vs. spatially averaging.

Likes 0

Dislikes 0

**Response**

Thank you for your comment. The IMAGE array data does represent high geomagnetic latitude observations and this is why (alpha) scaling of the determined geoelectric field amplitudes is necessary for carrying out analyses at lower latitude locations. Based on the past experiences with the IMAGE data, it is not expected that the coast effect has a significant effect on geomagnetic fields that were used in the extreme value analysis.

**Larisa Loyferman - CenterPoint Energy Houston Electric, LLC - 1 - Texas RE**

**Answer** Yes

**Document Name**

**Comment**

CenterPoint Energy agrees with the proposed supplemental GMD event and the description in the white paper. CenterPoint Energy believes the conservative approach is appropriate and reasonable and is the result of successful collaboration between GMD research experts, the space agency experts, and modeling experts from the power industry.

Likes 0

Dislikes 0

Question 2

**Response**

Thank you for your comment.

**Michael Shaw - Lower Colorado River Authority - 6, Group Name LCRA Compliance**

**Answer** Yes

**Document Name**

**Comment**

Applying a higher magnitude, localized event would seem to be prudent for assessing that type of phenomenon per FERC's request.

Likes 0

Dislikes 0

**Response**

Thank you for your comment.

**Thomas Foltz - AEP - 5**

**Answer** Yes

**Document Name**

**Comment**

AEP agrees with the methodology behind the *Supplemental GMD Event Description*, but has concerns with how the standard has been revised to perform two separate assessments.

Likes 0

Dislikes 0

**Response**

**Question 2**

Thank you for your comment. The SDT purposely is requesting two separate thermal assessments be done for transformers that exceed the GIC thresholds: One for the benchmark event and one for the supplemental event. The supplemental assessment is intended to address local enhancements. The benchmark assessment may result in a Corrective Action Plan, but the supplemental assessment does not.

**Terry Harbour - Berkshire Hathaway Energy - MidAmerican Energy Co. - 1**

<b>Answer</b>	Yes
<b>Document Name</b>	
<b>Comment</b>	
Likes	0
Dislikes	0

**Response**

**Sergio Banuelos - Tri-State G and T Association, Inc. - 1,3,5 - MRO,WECC**

<b>Answer</b>	Yes
<b>Document Name</b>	
<b>Comment</b>	
Likes	0
Dislikes	0

**Response**

**Chris Scanlon - Exelon - 1**

Question 2

Answer	Yes
--------	-----

Document Name	
---------------	--

Comment	
---------	--

--	--

Likes	0
-------	---

Dislikes	0
----------	---

<b>Response</b>
-----------------

--

<b>Michael Buyce - City Utilities of Springfield, Missouri - 1</b>
--

Answer	Yes
--------	-----

Document Name	
---------------	--

Comment	
---------	--

--	--

Likes	0
-------	---

Dislikes	0
----------	---

<b>Response</b>
-----------------

--

<b>James Anderson - CMS Energy - Consumers Energy Company - 1,3,4,5</b>
---

Answer	Yes
--------	-----

Document Name	
---------------	--

Comment	
---------	--

--	--

Question 2

Likes 0

Dislikes 0

Response

**Brian Van Gheem - ACES Power Marketing - 6 - NA - Not Applicable, Group Name** ACES Standards Collaborators

**Answer** Yes

**Document Name**

**Comment**

Likes 0

Dislikes 0

Response

**Ruida Shu - Northeast Power Coordinating Council - 1,2,3,4,5,6,7,8,9,10 - NPCC, Group Name** RSC no Hydro One, HQ and IESO

**Answer** Yes

**Document Name**

**Comment**

Likes 0

Dislikes 0

Response

Question 2

**Quintin Lee - Eversource Energy - 1**

Answer Yes

Document Name

Comment

Likes 0

Dislikes 0

Response

**Douglas Webb - Douglas Webb On Behalf of: Chris Bridges, Great Plains Energy - Kansas City Power and Light Co., 3, 6, 5, 1; Harold Wyble, Great Plains Energy - Kansas City Power and Light Co., 3, 6, 5, 1; James McBee, Great Plains Energy - Kansas City Power and Light Co., 3, 6, 5, 1; Jessica Tucker, Great Plains Energy - Kansas City Power and Light Co., 3, 6, 5, 1; - Douglas Webb**

Answer Yes

Document Name

Comment

Likes 0

Dislikes 0

Response

**Donald Lock - Talen Generation, LLC - 5**

Answer Yes



Question 2

Document Name

Comment

Likes 0

Dislikes 0

Response

Glen Farmer - Avista - Avista Corporation - 5

Answer Yes

Document Name

Comment

Likes 0

Dislikes 0

Response

Colby Bellville - Colby Bellville On Behalf of: Dale Goodwine, Duke Energy , 6, 5, 3, 1; - Colby Bellville, Group Name Duke Energy

Answer Yes

Document Name

Comment

Likes 0

Question 2

Dislikes 0

Response

Jeffrey Watkins - Jeffrey Watkins On Behalf of: Eric Schwarzrock, Berkshire Hathaway - NV Energy, 5; - Jeffrey Watkins

Answer Yes

Document Name

Comment

Likes 0

Dislikes 0

Response

Eric Shaw - Eric Shaw On Behalf of: Lee Maurer, Oncor Electric Delivery, 1; - Eric Shaw

Answer Yes

Document Name

Comment

Likes 0

Dislikes 0

Response

Laurie Williams - PNM Resources - Public Service Company of New Mexico - 1

Question 2

Answer Yes

Document Name

Comment

Likes 0

Dislikes 0

Response

Karie Barczak - DTE Energy - Detroit Edison Company - 3

Answer Yes

Document Name

Comment

Likes 0

Dislikes 0

Response

Neil Swearingen - Salt River Project - 1,3,5,6 - WECC

Answer Yes

Document Name

Comment

Question 2

Likes 0

Dislikes 0

Response

Dana Klem - MRO - 1,2,3,4,5,6 - MRO, Group Name MRO NSRF

Answer Yes

Document Name

Comment

Likes 0

Dislikes 0

Response

Laura Nelson - IDACORP - Idaho Power Company - 1

Answer Yes

Document Name

Comment

Likes 0

Dislikes 0

Response

Question 2

**Michelle Amarantos - APS - Arizona Public Service Co. - 1**

Answer Yes

Document Name

Comment

Likes 0

Dislikes 0

Response

**Gerry Huitt - Xcel Energy, Inc. - 5**

Answer Yes

Document Name

Comment

Likes 0

Dislikes 0

Response

**Robert Blackney - Edison International - Southern California Edison Company - 1,3,5,6 - WECC**

Answer Yes

Document Name

Comment

Question 2

Likes 0

Dislikes 0

Response

Daniel Grinkevich - Con Ed - Consolidated Edison Co. of New York - 1

Answer Yes

Document Name

Comment

Likes 0

Dislikes 0

Response

Aaron Cavanaugh - Bonneville Power Administration - 1,3,5,6 - WECC

Answer Yes

Document Name

Comment

Likes 0

Dislikes 0

Response

Question 2

**Ann Ivanc - FirstEnergy - FirstEnergy Solutions - 6**

**Answer** Yes

**Document Name**

**Comment**

Likes 0

Dislikes 0

**Response**

**RoLynda Shumpert - SCANA - South Carolina Electric and Gas Co. - 1,3,5,6 - SERC**

**Answer** Yes

**Document Name**

**Comment**

Likes 0

Dislikes 0

**Response**

**Lauren Price - American Transmission Company, LLC - 1**

**Answer** Yes

**Document Name**

Question 2

Comment

Likes 0

Dislikes 0

Response

Joe O'Brien - NiSource - Northern Indiana Public Service Co. - 6

Answer Yes

Document Name

Comment

Likes 0

Dislikes 0

Response

Randy Buswell - VELCO -Vermont Electric Power Company, Inc. - 1

Answer Yes

Document Name

Comment

Likes 0

Dislikes 0



Question 2

Response

Richard Vine - California ISO - 2

Answer

Document Name

Comment

The California ISO supports the joint comments of the ISO/RTO Standards Review Committee

Likes 0

Dislikes 0

Response

Thank you for supporting the comments of the IRC Standards Review Committee (i.e., ISO/RTO Standards Review Committee).

Thomas Rafferty - Edison International - Southern California Edison Company - 5

Answer

Document Name

Comment

Please refer to comments submitted by Robert Blackney on behalf of Southern California Edison

Likes 0

Dislikes 0

Response

No comments were submitted.

David Ramkalawan - Ontario Power Generation Inc. - 5

Answer

## Question 2

## Document Name

## Comment

While OPG agrees with the technical content of the Supplemental GMD Event Description white paper the SDT approach ends up with two type of GMD events the Benchmark and the Supplemental; OPG is of the opinion that they should be amalgamated in one GMD type of events (albeit this may require GMD benchmark event definition revision). As stated in question #1 OPG believes that Supplemental GMD event assessment will render the Benchmark GMD event assessment obsolete (based on the more stringent condition) and thus will be an unnecessary budgetary burden.

Likes 0

Dislikes 0

## Response

The SDT is being responsive to the Standards Authorization Request. The existing standard already has a vulnerability assessment requirement that is approved, and effective and subject to compliance by applicable registered entities. The supplemental assessment has been added to address local enhancements, but without the requirement of a Corrective Action Plan. The comment is suggesting an alternative threshold or benchmark to the existing standard which is outside the scope of the SDT and should be addressed in a new SAR.

## Payam Farahbakhsh - Hydro One Networks, Inc. - 1

## Answer

## Document Name

## Comment

We do not agree or disagree with the white paper. We believe that our industry's experience with GMD is not mature enough to adopt one specific approach to GMD assessment. The existing and recently developed assessment methodologies can be eventually verified by allowing the industry to collect GMD monitoring data and do further research.

Again, we disagree with the standard specifying methodologies for the responsible entities. We believe that this approach should be an option (in the guidelines or documented as an implementation guidance) but not the only option.

Likes 1

Hydro One Networks, Inc., 3, Malozewski Paul

Question 2

Dislikes 0

**Response**

The SDT is being responsive to the Standards Authorization Request. The existing standard already has a vulnerability assessment requirement that is approved, and effective and subject to compliance by applicable registered entities. The supplemental assessment has been added to address local enhancements, but without the requirement of a Corrective Action Plan. The comment is suggesting an alternative threshold or benchmark to the existing standard which is outside the scope of the SDT and should be addressed in a new SAR. The Transformer Thermal Impact Assessment White Paper and Screening Criterion for Transformer Thermal Impact Assessment documents have provided the technical foundation and methodologies that can be used to conduct transformer temperature rise calculations for both the benchmark case and the supplemental case.

**Rachel Coyne - Texas Reliability Entity, Inc. - 10**

**Answer**

**Document Name**

**Comment**

Texas RE does not have comments on this question.

Likes 0

Dislikes 0

**Response**

## Question 3

**3. The SDT established an 85 A per phase screening criterion for determining which power transformers are required to be assessed for thermal impacts from a supplemental GMD event in Requirement R10. Justification for this threshold is provided in the revised *Screening Criterion for Transformer Thermal Impact Assessment* white paper. Do you agree with the proposed 85 A per phase screening criterion and the technical justification for this criterion that has been added to the white paper? If you do not agree, or if you agree but have comments or suggestions for the screening criterion and revisions to the white paper provide your recommendation and explanation.**

**Michael Shaw - Lower Colorado River Authority - 6, Group Name LCRA Compliance**

**Answer** No

**Document Name**

**Comment**

The technical basis is not clear. The standard references 2-5 minutes for the supplemental event, but this timeframe is not clearly referenced within the thermal impact assessment white paper.

Likes 0

Dislikes 0

**Response**

Thank you for your comment. The thermal impact assessment white paper describes possible ways to carry out a thermal impact assessment for any given GIC(t) waveform, whether it corresponds to the benchmark or supplemental benchmark waveforms. The description of the GIC(t) waveforms can be found in the benchmark and supplemental benchmark GMD event white papers.

**Mike Smith - Manitoba Hydro - 1, Group Name Manitoba Hydro**

**Answer** No

**Document Name**

**Comment**

**Question 3**

Both benchmarked and supplemental GMD calculations attempt to limit the hot spot to 172 degrees as a screening criterion. Given the lower probability of the local 12 V/km GMD enhancements, perhaps the full 200C could be utilized and a screening criteria closer to 150 A used before a full thermal assessment is undertaken.

Likes 0

Dislikes 0

**Response**

Thank you for your comment. The probability of occurrence of a local 12 V/peak is the same as the probability of occurrence of spatially averaged 8 V/km. The impact to the system would be different (local as opposed to wide-scale). The screening criteria are intended to flag instances where additional consideration should be given to specific transformers.

**Michelle Amarantos - APS - Arizona Public Service Co. - 1**

**Answer** No

**Document Name**

**Comment**

Requirement R6 requires a thermal impact assessment for applicable BES power transformers where the maximum effective GIC value required in Requirement 5, Part 5.1 is 75 A per phase or greater. Requirement R10 requires a supplemental thermal impact assessment for applicable BES power transformers where the maximum effective GIC value provided in Requirement R9, Part 9.1 is 85 A per phase or greater. AZPS is concerned that the use of two (2) different thresholds in different analyses (benchmark and supplemental) increases the potential for inconsistency in the results of the assessments. Accordingly, AZPS suggests using a consistent value per phase in both the primary and the supplemental assessments. While AZPS would recommend a single 85 A per phase or greater for consistency, its request is primarily for consistency, which could be achieved at either value.

Likes 0

Dislikes 0

**Response**

## Question 3

Thank you for your comment. Different screening thresholds were selected because benchmark and supplemental benchmark waveforms are different and their effects on transformers are different. The temperature thresholds are consistent, i.e., the thermal effects on a transformer are characterized by peak temperatures.

**Eric Shaw - Eric Shaw On Behalf of: Lee Maurer, Oncor Electric Delivery, 1; - Eric Shaw**

**Answer** No

**Document Name**

**Comment**

The screening threshold of 75 A per phase used in the benchmark GMD event should also be used in the thermal impact assessment for the supplemental GMD event because it was determined to be the appropriate value to ensure protection of the transformer.

Likes 0

Dislikes 0

**Response**

Thank you for your comment. Different screening thresholds were selected because benchmark and supplemental benchmark waveforms are different and their effects on transformers are different. The temperature thresholds are consistent, i.e., the thermal effects on a transformer are characterized by peak temperatures.

**Chris Scanlon - Exelon - 1**

**Answer** No

**Document Name**

**Comment**

The supplemental GMD waveform used as a justification to develop the 85A screening criteria is not provided, similar to that which is provided in Figure 2 for the benchmark event in the "Screening Criterion for Transformer Thermal Impact Assessment" white paper. Therefore, the relationship between the supplemental waveform and hot-spot results shown in Figure 3 cannot be fully understood. Additionally, it is not stated which geo-electric scaling factor (B) was used for the supplemental event.

Likes 0

Question 3

Dislikes 0

**Response**

Thank you for your comment. The supplemental GMD waveform is described in the Supplemental GMD Event Description white paper. Figure 2 is produced as an illustrative example corresponding to a small portion of the benchmark GMD event. The curves shown in Figure 3 of the screening criterion white paper were obtained by carrying out thousands of thermal simulations considering every possible combination of  $GIC_E$  and  $GIC_N$  as described in Equation (5) of the Thermal Impact Assessment white paper. Beta factors are imbedded in  $GIC_E$  and  $GIC_N$  and the results in Figure 3 are not specific to any beta factor.

**Marty Hostler - Northern California Power Agency - 5**

**Answer** No

**Document Name**

**Comment**

. There should be a threshold of greater than 500 MVA, similar to CIP standards: High, Medium, and Low impact rating criteria.

Likes 0

Dislikes 0

**Response**

Thank you for your comment. The applicability for the TPL-007 standard is to BES transformers that have a high-side wye-grounded connection that is 200 kV and above.

**Dennis Sismaet - Northern California Power Agency - 6**

**Answer** No

**Document Name**

**Comment**

There should be a threshold of greater than 500 MVA, similar to CIP standards: High, Medium, and Low impact rating criteria.

Likes 0

## Question 3

Dislikes 0

**Response**

Thank you for your comment. The applicability for the TPL-007 standard is to BES transformers that have a high-side wye-grounded connection that is 200 kV and above.

**William Harris - Foundation for Resilient Societies - 8**

<b>Answer</b>	No
---------------	----

<b>Document Name</b>	
----------------------	--

**Comment**

Sudden reversal events can occur at far lower thresholds. A high dB/dT can occur during a relatively weak GMD event. Perhaps sensible to have two types of hazard, but if the thresholds are too high, the grid will not be protected. 20 amps per phase would be consistent with INL testing of 138 kV transformer in year 2013,. Generator equipment is also susceptible to GMD damage well below 75 amps per phase.

Likes 0

Dislikes 0

**Response**

Thank you for your comment. The SDT has used consistent geomagnetic field measurements to estimate benchmark events the details of which are found in the white papers. The thresholds of 75 A/phase and 85 A/phase for transformer impact screening were selected on the basis of conservative thermal models. For additional explanation please see the response to Resilient Societies at the end of this document.

**Lauren Price - American Transmission Company, LLC - 1**

<b>Answer</b>	Yes
---------------	-----

<b>Document Name</b>	
----------------------	--

**Comment**

Agree with the proposed screening criteria of 85 A per phase for the Supplemental Event as the threshold for assessing power transformers since it is consistent with the screening criteria used to establish the 75 A per phase threshold for the Benchmark Event.



Question 3

Likes 0

Dislikes 0

**Response**

Thank you for your comment.

**Thomas Foltz - AEP - 5**

**Answer** Yes

**Document Name**

**Comment**

AEP agrees with the 85A criterion, but is concerned about the potential duplication of work driven by the need to perform two separate assessments.

Likes 0

Dislikes 0

**Response**

Thank you for your comment. The SDT purposely is requesting two separate thermal assessments be done for transformers that exceed the GIC thresholds: One for the benchmark event and one for the supplemental event. The supplemental assessment is intended to address local enhancements. The benchmark assessment may result in a Corrective Action Plan, but the supplemental assessment does not.

**Daniel Grinkevich - Con Ed - Consolidated Edison Co. of New York - 1**

**Answer** Yes

**Document Name**

**Comment**

While the 85 Amps per phase screening criterion is acceptable, it should be noted that the GIC flow values are dependent on the accuracy of the modeling program from which they are derived. For test cases that have been run using the latest version of GIC modeling and software, there were significant large currents in excess of 85 Amps in the boundary areas of observation. This behavior is analogous with

## Question 3

the slack or swing buses that are used in AC power flow analysis. Specifically, the boundary buses take on whatever resulting flows will enable a solution for the GIC model flow, without taking into regard any structures that exist beyond these points. As a result, the boundary current flow conditions are not an accurate representation of the anticipated neutral and phase flow conditions, and if taken at face value, would result in unnecessary corrective actions to be taken. It is therefore critical that all modeling efforts anticipate these conditions to occur and ensure that the models are sufficiently adequate in size and scope to provide accurate results within the regions of interest, as well as to interpret any anomalies that might arise from artificial limitations of the GIC modeling programs.

Likes	0
-------	---

Dislikes	0
----------	---

## Response

Thank you for your comment. The SDT agrees that accuracy of models and tools is very important and that their improvement and validation are the main drivers for the research plan.

**sean erickson - Western Area Power Administration - 1**

Answer	Yes
--------	-----

Document Name	<a href="#">08_SPP_TPLTF_Discussion_Summary_on_1st_Release_TPL-007-2.docx</a> <sup>8</sup>
---------------	--

## Comment

please see attached form completed by the [TPL-Task Force](#)<sup>9</sup>

Likes	0
-------	---

Dislikes	0
----------	---

## Response

Thank you for providing the TPL-Task Force information.

<sup>8</sup> TPLTF document is found at the end of this document in Attachment 1.

<sup>9</sup> TPLTF document is found at the end of this document in Attachment 1.

**Question 3**

**Larisa Loyferman - CenterPoint Energy Houston Electric, LLC - 1 - Texas RE**

**Answer** Yes

**Document Name**

**Comment**

CenterPoint Energy agrees with the approach used by the SDT to arrive at 85 A per phase as a screening criterion for determining which power transformers are required to be assessed for thermal impacts from a supplemental GMD event in R10. CenterPoint Energy appreciates the diligent efforts of the SDT in ensuring consistency between the approach used to develop the screening criterion in R10 and the approach used to develop the screening criterion in R6.

Likes 0

Dislikes 0

**Response**

Thank you for your comment.

**Joshua Eason - Joshua Eason On Behalf of: Michael Puscas, ISO New England, Inc., 2; - Joshua Eason**

**Answer** Yes

**Document Name**

**Comment**

Based on comparing Tables 1 and 2 in the Screen Criterion for Transformer Thermal Impact Assessment, the 85 Ampere screening criteria is as conservative as the 75 Ampere screening criteria associated with the benchmark event.

Likes 0

Dislikes 0

**Response**

Thank you for your comment.

## Question 3

**Stephanie Burns - Stephanie Burns On Behalf of: Michael Moltane, International Transmission Company Holdings Corporation, 1; - Stephanie Burns**

**Answer** Yes

**Document Name**

**Comment**

As the supplemental event is more severe than the benchmark event, we agree that the threshold for transformer thermal assessment should correspondingly be raised as well. Through analysis, the SDT determined that 85 A per phase was a conservative threshold to apply for the supplemental event.

Likes 0

Dislikes 0

**Response**

Thank you for your comment.

**Quintin Lee - Eversource Energy - 1**

**Answer** Yes

**Document Name**

**Comment**

Just a question, but have transformer manufacturers been asked if they agree that 85 A is an acceptable threshold for all of their transformer designs (core-form, shell-form), configurations (3-phase autotransformers, 1-phase autotransformers, 3-phase delta-wye transformers, etc.), and vintages (old, new)?

Likes 0

Dislikes 0

**Response**

**Question 3**

Thank you for your comment. Transformer manufacturers have been involved with the Geomagnetic Disturbance Task Force (GMDTF) and their input has informed the development of TPL-007. The thresholds used in the standard assume single-phase construction and a healthy transformer.

**Ruida Shu - Northeast Power Coordinating Council - 1,2,3,4,5,6,7,8,9,10 - NPCC, Group Name** RSC no Hydro One, HQ and IESO

**Answer** Yes

**Document Name**

**Comment**

While the 85 Amps per phase screening criterion is acceptable, it should be noted that the GIC flow values are dependent on the accuracy of the modeling program from which they are derived. For test cases that have been run using the latest version of GIC modeling and software, there were significant large currents in excess of 85 Amps in the boundary areas of observation. This behavior is analogous with the slack or swing buses that are used in AC power flow analysis. Specifically, the boundary buses take on whatever resulting flows will enable a solution for the GIC model flow, without taking into regard any structures that exist beyond these points. As a result, the boundary current flow conditions are not an accurate representation of the anticipated neutral and phase flow conditions, and if taken at face value, would result in unnecessary corrective actions to be taken. It is therefore critical that all modeling efforts anticipate these conditions to occur and ensure that the models are sufficiently adequate in size and scope to provide accurate results within the regions of interest, as well as to interpret any anomalies that might arise from artificial limitations of the GIC modeling programs.

“Figure 2: Metallic hot spot temperatures calculated using the benchmark GMD event” from the screening criterion document provides a useful visual, can the drafting team additionally provide a similar chart and the data for the supplemental GMD event?

Likes 0

Dislikes 0

**Response**

Thank you for your comment. The results of the NERC GMD research plan associated with FERC Order No. 830 may provide more granularity. The SDT agrees that accuracy of models and tools is very important and that their improvement and validation are the main drivers for the research plan. The upper bound of hot spot temperatures are provided in Figure 3 of the Screening Criterion for Transformer Thermal Impact Assessment white paper and in Tables 1 and 2 of Appendix 1 of the same document.

## Question 3

**Shannon Mickens - Southwest Power Pool, Inc. (RTO) - 2 - SPP RE, Group Name** SPP Standards Review Group

**Answer** Yes

**Document Name** 2013-03\_IB\_Comment\_Form\_June\_2017\_svm.docx

**Comment**

Given the use of the 12 V/km geoelectric field amplitude for the supplemental GMD event, the SPP Standards Review Group agrees with the proposed 85 Amp threshold justified in the *Screening Criterion for Transformer Thermal Impact Assessment* white paper. We suggest that the proposed change on page 11 of the white paper stating “because the supplemental waveform has a sharper peak, the peak metallic hot spot temperatures associated with the supplemental waveform are slightly lower than those associated with the benchmark waveform” be clarified. In other words, this statement is counterintuitive given that the increased supplemental time-series waveform peak value implies higher GIC flows that, when experienced by a transformer will lead potentially higher metallic hot spot temperatures.

Likes 0

Dislikes 0

**Response**

Thank you for your comment. The SDT agrees with the comment and has modified the explanation in the white paper as follows: Because the supplemental waveform has a sharper peak, the peak metallic hot spot temperatures associated with the supplemental waveform for the same peak current are slightly lower than those associated with the benchmark waveform. In other words, for the same peak current value, the duration is relatively shorter with the supplemental waveform, and shorter duration means lower temperature. However, higher peak currents will occur with the supplemental benchmark, therefore, higher peak hot spot temperatures will occur.

**Elizabeth Axson - Electric Reliability Council of Texas, Inc. - 2, Group Name** IRC Standards Review Committee

**Answer** Yes

**Document Name**

**Comment**

Based on comparing Tables 1 and 2 in the Screen Criterion for Transformer Thermal Impact Assessment, the 85 Ampere screening criterion is as conservative as the 75 Ampere screening criteria associated with the benchmark event.

Question 3

Likes 0

Dislikes 0

**Response**

Thank you for your comment.

**Randy Buswell - VELCO -Vermont Electric Power Company, Inc. - 1**

**Answer** Yes

**Document Name**

**Comment**

Likes 0

Dislikes 0

**Response**

**Joe O'Brien - NiSource - Northern Indiana Public Service Co. - 6**

**Answer** Yes

**Document Name**

**Comment**

Likes 0

Dislikes 0

**Response**

**Question 3**

**RoLynda Shumpert - SCANA - South Carolina Electric and Gas Co. - 1,3,5,6 - SERC**

**Answer** Yes

**Document Name**

**Comment**

Likes 0

Dislikes 0

**Response**

**Ann Ivanc - FirstEnergy - FirstEnergy Solutions - 6**

**Answer** Yes

**Document Name**

**Comment**

Likes 0

Dislikes 0

**Response**

**Aaron Cavanaugh - Bonneville Power Administration - 1,3,5,6 - WECC**

**Answer** Yes

**Document Name**

**Comment**



Question 3

Likes 0

Dislikes 0

**Response**

**Robert Blackney - Edison International - Southern California Edison Company - 1,3,5,6 - WECC**

**Answer** Yes

**Document Name**

**Comment**

Likes 0

Dislikes 0

**Response**

**Gerry Huitt - Xcel Energy, Inc. - 5**

**Answer** Yes

**Document Name**

**Comment**

Likes 0

Dislikes 0

**Response**

**Question 3**

**Chantal Mazza - Hydro-Québec TransEnergie - 1,2 - NPCC**

**Answer** Yes

**Document Name**

**Comment**

Likes 0

Dislikes 0

**Response**

**Laura Nelson - IDACORP - Idaho Power Company - 1**

**Answer** Yes

**Document Name**

**Comment**

Likes 0

Dislikes 0

**Response**

**Dana Klem - MRO - 1,2,3,4,5,6 - MRO, Group Name MRO NSRF**

**Answer** Yes

**Document Name**

Question 3

**Comment**

Likes 0

Dislikes 0

**Response**

Neil Swearingen - Salt River Project - 1,3,5,6 - WECC

**Answer** Yes

**Document Name**

**Comment**

Likes 0

Dislikes 0

**Response**

Nicolas Turcotte - Hydro-Québec TransEnergie - 1

**Answer** Yes

**Document Name**

**Comment**

Likes 0

Dislikes 0

Question 3

Response

Karie Barczak - DTE Energy - Detroit Edison Company - 3

Answer Yes

Document Name

Comment

Likes 0

Dislikes 0

Response

Laurie Williams - PNM Resources - Public Service Company of New Mexico - 1

Answer Yes

Document Name

Comment

Likes 0

Dislikes 0

Response

Jeffrey Watkins - Jeffrey Watkins On Behalf of: Eric Schwarzrock, Berkshire Hathaway - NV Energy, 5; - Jeffrey Watkins

Answer Yes

Question 3

Document Name

Comment

Likes 0

Dislikes 0

Response

Colby Bellville - Colby Bellville On Behalf of: Dale Goodwine, Duke Energy , 6, 5, 3, 1; - Colby Bellville, Group Name Duke Energy

Answer

Yes

Document Name

Comment

Likes 0

Dislikes 0

Response

Glen Farmer - Avista - Avista Corporation - 5

Answer

Yes

Document Name

Comment

Likes 0

Question 3

Dislikes 0

Response

Donald Lock - Talen Generation, LLC - 5

Answer Yes

Document Name

Comment

Likes 0

Dislikes 0

Response

Douglas Webb - Douglas Webb On Behalf of: Chris Bridges, Great Plains Energy - Kansas City Power and Light Co., 3, 6, 5, 1; Harold Wyble, Great Plains Energy - Kansas City Power and Light Co., 3, 6, 5, 1; James McBee, Great Plains Energy - Kansas City Power and Light Co., 3, 6, 5, 1; Jessica Tucker, Great Plains Energy - Kansas City Power and Light Co., 3, 6, 5, 1; - Douglas Webb

Answer Yes

Document Name

Comment

Likes 0

Dislikes 0

Response

Question 3

**Pamela Hunter - Southern Company - Southern Company Services, Inc. - 1,3,5,6 - SERC, Group Name Southern Company**

**Answer** Yes

**Document Name**

**Comment**

Likes 0

Dislikes 0

**Response**

**David Ramkalawan - Ontario Power Generation Inc. - 5**

**Answer** Yes

**Document Name**

**Comment**

Likes 0

Dislikes 0

**Response**

**Brian Van Gheem - ACES Power Marketing - 6 - NA - Not Applicable, Group Name ACES Standards Collaborators**

**Answer** Yes

**Document Name**

Question 3

**Comment**

Likes 0

Dislikes 0

**Response**

**James Anderson - CMS Energy - Consumers Energy Company - 1,3,4,5**

**Answer** Yes

**Document Name**

**Comment**

Likes 0

Dislikes 0

**Response**

**Michael Buyce - City Utilities of Springfield, Missouri - 1**

**Answer** Yes

**Document Name**

**Comment**

Likes 0

Dislikes 0



Question 3

Response

Sergio Banuelos - Tri-State G and T Association, Inc. - 1,3,5 - MRO,WECC

Answer Yes

Document Name

Comment

Likes 0

Dislikes 0

Response

Terry Harbour - Berkshire Hathaway Energy - MidAmerican Energy Co. - 1

Answer Yes

Document Name

Comment

Likes 0

Dislikes 0

Response

Rachel Coyne - Texas Reliability Entity, Inc. - 10

Answer

Question 3

**Document Name**

**Comment**

Texas RE does not have comments on this question.

Likes 0

Dislikes 0

**Response**

**Payam Farahbakhsh - Hydro One Networks, Inc. - 1**

**Answer**

**Document Name**

**Comment**

Consistent with our comments above, it should be up to the responsible entity to decide what the appropriate threshold is based on the responsible entities justification, risk assessment, and risk tolerance level. The whitepapers or any other research can be used to support the justification.

Likes 1

Hydro One Networks, Inc., 3, Malozewski Paul

Dislikes 0

**Response**

Thank you for your comment. The standard provides the flexibility to use technically-justified technologies and models to carry out transformer thermal assessments. The temperature thresholds in IEEE STD. 57.91, which inform the 75 A/phase and 85 A/phase screening thresholds, are prudent industry recommendations that apply to healthy transformers. Applicable entities should ensure that asset condition and other factors are taken into account in the thermal assessment.

**Thomas Rafferty - Edison International - Southern California Edison Company - 5**

**Answer**

Question 3

**Document Name**

**Comment**

Please refer to comments submitted by Robert Blackney on behalf of Southern California Edison

Likes 0

Dislikes 0

**Response**

No comments were submitted.

**Richard Vine - California ISO - 2**

**Answer**

**Document Name**

**Comment**

The California ISO supports the joint comments of the ISO/RTO Standards Review Committee

Likes 0

Dislikes 0

**Response**

Thank you for supporting the comments of the IRC Standards Review Committee (i.e., ISO/RTO Standards Review Committee).

## Question 4

4. The SDT revised the *Transformer Thermal Impact Assessment* white paper to include the supplemental GMD event. Do you agree with the revisions to the white paper? If you do not agree, or if you agree but have comments or suggestions on the revisions to the white paper provide your recommendation and explanation.

Dennis Sismaet - Northern California Power Agency - 6

Answer No

Document Name

Comment

There should be a threshold of greater than 500 MVA, similar to CIP standards: High, Medium, and Low impact rating criteria.

Likes 0

Dislikes 0

Response

Thank you for your comment. The applicability for the TPL-007 standard is to BES transformers that have a high-side wye-grounded connection that is 200 kV and above.

Marty Hostler - Northern California Power Agency - 5

Answer No

Document Name

Comment

There should be a threshold of greater than 500 MVA, similar to CIP standards: High, Medium, and Low impact rating criteria.

Likes 0

Dislikes 0

Response

**Question 4**

Thank you for your comment. The applicability for the TPL-007 standard is to BES transformers that have a high-side wye-grounded connection that is 200 kV and above.

**Donald Lock - Talen Generation, LLC - 5**

**Answer** No

**Document Name**

**Comment**

NERC’s Screening Criterion for Transformer Thermal Impact Assessment and Transformer Thermal Impact Assessment White Paper state that TPL-007-2 R6 and R10 analyses can in some cases be addressed simply by comparing Screening Criterion for Transformer Thermal Impact Assessment Table 1 and 2 values to IEEE emergency loading criteria. The statement in footnote 5 of the Transformer Thermal Impact Assessment White Paper that the “peak GIC(t)” value is to be used in this exercise may cause some confusion, however. This appears to be the “maximum effective GIC” reported in R5.1 and R9.1 of TPL-007-2, given that the Screening Criterion for Transformer Thermal Impact Assessment uses the term “effective GIC” in discussing Tables 1 and 2, but it’s difficult to be certain without a clarification or (better) harmonization of terms between the standard and its supporting material.

NERC should provide default tables by transformer type (single phase, 5-legged core 3-phase, etc) similar to Table 1 and 2 for cases in which the first-cut process discussed above does not demonstrate that transformers are acceptable as-is, since the alternatives in the Thermal Impact Assessment and Transformer Thermal Impact Assessment White Paper will often prove impractical. OEM GIC capability curves are seldom available, and the same is true for the input data needed for thermal response simulations. Rather than making every GO and TO in North America seek out consultants with generic information in these respects (if there are any) it would be better to simply present the best available OK/not-OK boundaries up-front.

Likes 0

Dislikes 0

**Response**

Thank you for your comment. Current knowledge does not allow for generalized tables for different construction types. The tables used in the standard assume single-phase construction and a healthy unit. The assessment(s) can use other technically-justified assumptions.

Question 4

Tables 1 and 2 of the screening criterion white paper represent the best available upper boundaries. The results of the NERC GMD research plan associated with FERC Order No. 830 may provide more granularity. The SDT agrees that accuracy of models and tools is very important and that their improvement and validation are the main drivers for the research plan.

**Mike Smith - Manitoba Hydro - 1, Group Name** Manitoba Hydro

**Answer** No

**Document Name**

**Comment**

We believe that we need more experience with GMD before moving on to include more time consuming analysis. We also noticed that, Figure 1 and Figure 3 in the *Screening Criterion for Transformer Thermal Impact Assessment* are on different temperature scales (80-300 vs 0-300) so they are difficult to compare.

Likes 0

Dislikes 0

**Response**

Thank you for your comment. The Figure 3 y-axis has been updated. The SDT purposely is requesting two separate thermal assessments be done for transformers that exceed the GIC thresholds: One for the benchmark event and one for the supplemental event. The distinction between the benchmark and supplemental thermal assessments is the amplitudes and waveforms of the geoelectric field are different.

**Michael Shaw - Lower Colorado River Authority - 6, Group Name** LCRA Compliance

**Answer** No

**Document Name**

**Comment**

The standard references 2-5 minutes for the supplemental event, but this timeframe is not clearly referenced within the thermal impact assessment white paper.

Likes 0

## Question 4

Dislikes 0

**Response**

Thank you for your comment. The thermal impact assessment white paper describes possible ways to carry out a thermal impact assessment for any given GIC(t) waveform, whether it corresponds to the benchmark or supplemental benchmark waveforms. The description of the GIC(t) waveforms can be found in the benchmark and supplemental benchmark GMD event white papers.

**Chris Scanlon - Exelon - 1**

Answer Yes

Document Name

**Comment**

Figure 17 indicates that the load is at the 70% level, but the previous paragraph states that the load is at the 75% level. It is unclear whether the chart or just the description needs to be revised.

Likes 0

Dislikes 0

**Response**

Thank you for your comment. The SDT has updated the Figure caption.

**Shannon Mickens - Southwest Power Pool, Inc. (RTO) - 2 - SPP RE, Group Name SPP Standards Review Group**

Answer Yes

Document Name

**Comment**

The SPP Standards Review Group agrees with the changes in the *Transformer Thermal Impact Assessment* white paper, with the exception of the explanation provided for Table 2 on page 5. Similar to the comment made regarding the counterintuitive language in the *Screening Criterion for Transformer Thermal Impact Assessment* white paper, it is not clear why metallic hot spot temperatures are reduced for the supplemental GMD event for the same effective GIC and transformer bulk oil temperature. Additional clarity on this point would improve the

## Question 4

ability of applicable entities to rely upon the reference data provided. The group recommends adding white paper language similar to that suggested in Question Q3.

The group would like to highlight that the study of supplemental GMD event conditions may cause a significantly larger number of transformers to be added for assessed by Transmission Owners and Generator Owners. Given that the analytical tools and modeling software available for this type of analysis are limited, as well as the fact that most manufacturers supplying power transformers to U.S. customers do not include data necessary to complete detailed thermal modeling with transformer test reports, the additional effort to satisfy the supplemental GMD event analysis will be arduous. The group recommends that the SDT consider the reality that these tools are merely in their infancy across the industry, and additional time to develop, deploy, and train on them should be included in the TPL-007-2 implementation plan to complete transformer thermal assessments for the supplemental GMD event.

Likes 0

Dislikes 0

## Response

Thank you for your comment. The SDT agrees with the comment regarding counter intuitive language in the first paragraph and has modified the explanation in the white paper as follows: Because the supplemental waveform has a sharper peak, the peak metallic hot spot temperatures associated with the supplemental waveform for the same peak current are slightly lower than those associated with the benchmark waveform.

The SDT is aware of the current limitations in knowledge and tools.

The supplemental assessment is additional work, but it is necessary to account for the impacts of local enhancements.

**Ruida Shu - Northeast Power Coordinating Council - 1,2,3,4,5,6,7,8,9,10 - NPCC, Group Name** RSC no Hydro One, HQ and IESO

Answer

Yes

Document Name

## Comment

Table 1 and 2 are useful to show the differences between the benchmark event and the supplemental, but some of the figures are not clear which GMD event was used to generate the GIC(t) time series. Can some additional language be added to clarify the GMD event of the figures in this document?



## Question 4

Also, there was some inconsistency in axis labels and units between the various figures, which makes it difficult to draw conclusions when comparing the charts. For example: A/phase versus Amps, minutes versus hours for the time scale. Can these charts be updated with uniform axis labels and units for comparative purposes?

Likes 0

Dislikes 0

## Response

Thank you for your comment. This version of the white paper is intended to illustrate different ways to carry out thermal transformer assessments. The time series used in the white paper are based on portions of the benchmark time series and are intended for illustrative purposes only. The Figures in the white papers are sufficiently clear for their intended use.

**Stephanie Burns - Stephanie Burns On Behalf of: Michael Moltane, International Transmission Company Holdings Corporation, 1; - Stephanie Burns**

**Answer** Yes

**Document Name**

## Comment

Per FERC's directive, the transformer thermal assessment was revised to not rely solely on spatially-averaged data and the SDT modified the standard to utilize the supplemental GMD event definition for the additional analysis requested by FERC.

Likes 0

Dislikes 0

## Response

Thank you for your comment.

**Eric Shaw - Eric Shaw On Behalf of: Lee Maurer, Oncor Electric Delivery, 1; - Eric Shaw**

**Answer** Yes

**Document Name**

## Question 4

**Comment**

We agree with the revisions to the white paper but disagree with the 85 A screening criterion as this may cause damage to the transformers because a thermal assessment will not be performed until 85 A.

Likes 0

Dislikes 0

**Response**

Thank you for your comment. Thermal impact on a transformer is quantified against temperature rise, which depends on the peak GIC(t) and its waveform. The 75 A/phase and 85 A/phase are equivalent in terms of hot spot temperature rise.

**Larisa Loyferman - CenterPoint Energy Houston Electric, LLC - 1 - Texas RE**

**Answer** Yes

**Document Name**

**Comment**

CenterPoint Energy agrees with the revisions to include the supplemental GMD event in the Transformer Thermal Impact Assessment white paper.

Likes 0

Dislikes 0

**Response**

Thank you for your comment.

**sean erickson - Western Area Power Administration - 1**

**Answer** Yes

**Document Name**

**Comment**

**Question 4**

[TPLTF](#)<sup>10</sup> Discussion: The group agrees with the changes in the *Transformer Thermal Impact Assessment* white paper, with the exception of the explanation provided for Table 2 on page 5. Similar to the comment made regarding the counterintuitive language in the *Screening Criterion for Transformer Thermal Impact Assessment* white paper, it is not clear why metallic hot spot temperatures are reduced for the supplemental GMD event for the same effective GIC and transformer bulk oil temperature. Additional clarity on this point would improve the ability of applicable entities to rely upon the reference data provided. The group recommends adding white paper language similar to that suggested in Question Q3.

The group would like to highlight that the study of supplemental GMD event conditions may cause a significantly larger number of transformers to be added for assessed by Transmission Owners and Generator Owners. Given that the analytical tools and modeling software available for this type of analysis are limited, as well as the fact that most manufacturers supplying power transformers to U.S. customers do not include data necessary to complete detailed thermal modeling with transformer test reports, the additional effort to satisfy the supplemental GMD event analysis will be arduous. The group recommends that the SDT consider the reality that these tools are merely in their infancy across the industry, and additional time to develop, deploy, and train on them should be included in the TPL-007-2 implementation plan to complete transformer thermal assessments for the supplemental GMD event.

Likes 0

Dislikes 0

**Response**

Thank you for your comment. The SDT is being responsive to the Standards Authorization Request. The existing standard already has a vulnerability assessment requirement that is approved, and effective and subject to compliance by applicable registered entities. The supplemental assessment has been added to address local enhancements, but without the requirement of a Corrective Action Plan.

**Terry Harbour - Berkshire Hathaway Energy - MidAmerican Energy Co. - 1**

**Answer** Yes

**Document Name**

**Comment**

<sup>10</sup> TPLTF document is found at the end of this document in Attachment 1.

Question 4

Likes 0

Dislikes 0

Response

Sergio Banuelos - Tri-State G and T Association, Inc. - 1,3,5 - MRO,WECC

Answer Yes

Document Name

Comment

Likes 0

Dislikes 0

Response

Elizabeth Axson - Electric Reliability Council of Texas, Inc. - 2, Group Name IRC Standards Review Committee

Answer Yes

Document Name

Comment

Likes 0

Dislikes 0

Response

Question 4

**Michael Buyce - City Utilities of Springfield, Missouri - 1**

**Answer** Yes

**Document Name**

**Comment**

Likes 0

Dislikes 0

**Response**

**James Anderson - CMS Energy - Consumers Energy Company - 1,3,4,5**

**Answer** Yes

**Document Name**

**Comment**

Likes 0

Dislikes 0

**Response**

**Brian Van Gheem - ACES Power Marketing - 6 - NA - Not Applicable, Group Name ACES Standards Collaborators**

**Answer** Yes

**Document Name**

**Question 4**

**Comment**

Likes 0

Dislikes 0

**Response**

**David Ramkalawan - Ontario Power Generation Inc. - 5**

**Answer** Yes

**Document Name**

**Comment**

Likes 0

Dislikes 0

**Response**

**Quintin Lee - Eversource Energy - 1**

**Answer** Yes

**Document Name**

**Comment**

Likes 0

Dislikes 0

Question 4

Response

Pamela Hunter - Southern Company - Southern Company Services, Inc. - 1,3,5,6 - SERC, Group Name Southern Company

Answer Yes

Document Name

Comment

Likes 0

Dislikes 0

Response

Douglas Webb - Douglas Webb On Behalf of: Chris Bridges, Great Plains Energy - Kansas City Power and Light Co., 3, 6, 5, 1; Harold Wyble, Great Plains Energy - Kansas City Power and Light Co., 3, 6, 5, 1; James McBee, Great Plains Energy - Kansas City Power and Light Co., 3, 6, 5, 1; Jessica Tucker, Great Plains Energy - Kansas City Power and Light Co., 3, 6, 5, 1; - Douglas Webb

Answer Yes

Document Name

Comment

Likes 0

Dislikes 0

Response

Question 4

Glen Farmer - Avista - Avista Corporation - 5

Answer Yes

Document Name

Comment

Likes 0

Dislikes 0

Response

Colby Bellville - Colby Bellville On Behalf of: Dale Goodwine, Duke Energy , 6, 5, 3, 1; - Colby Bellville, Group Name Duke Energy

Answer Yes

Document Name

Comment

Likes 0

Dislikes 0

Response

Jeffrey Watkins - Jeffrey Watkins On Behalf of: Eric Schwarzrock, Berkshire Hathaway - NV Energy, 5; - Jeffrey Watkins

Answer Yes

Document Name

Comment



Question 4

Likes 0

Dislikes 0

Response

Joshua Eason - Joshua Eason On Behalf of: Michael Puscas, ISO New England, Inc., 2; - Joshua Eason

Answer Yes

Document Name

Comment

Likes 0

Dislikes 0

Response

Laurie Williams - PNM Resources - Public Service Company of New Mexico - 1

Answer Yes

Document Name

Comment

Likes 0

Dislikes 0

Response

Question 4

**Karie Barczak - DTE Energy - Detroit Edison Company - 3**

**Answer** Yes

**Document Name**

**Comment**

Likes 0

Dislikes 0

**Response**

**Nicolas Turcotte - Hydro-Québec TransEnergie - 1**

**Answer** Yes

**Document Name**

**Comment**

Likes 0

Dislikes 0

**Response**

**Neil Swearingen - Salt River Project - 1,3,5,6 - WECC**

**Answer** Yes

**Document Name**

Question 4

Comment

Likes 0

Dislikes 0

Response

Dana Klem - MRO - 1,2,3,4,5,6 - MRO, Group Name MRO NSRF

Answer Yes

Document Name

Comment

Likes 0

Dislikes 0

Response

Laura Nelson - IDACORP - Idaho Power Company - 1

Answer Yes

Document Name

Comment

Likes 0

Dislikes 0

Question 4

Response

Chantal Mazza - Hydro-Québec TransEnergie - 1,2 - NPCC

Answer Yes

Document Name

Comment

Likes 0

Dislikes 0

Response

Michelle Amarantos - APS - Arizona Public Service Co. - 1

Answer Yes

Document Name

Comment

Likes 0

Dislikes 0

Response

Gerry Huitt - Xcel Energy, Inc. - 5

Answer Yes

Question 4

Document Name

Comment

Likes 0

Dislikes 0

Response

Robert Blackney - Edison International - Southern California Edison Company - 1,3,5,6 - WECC

Answer

Yes

Document Name

Comment

Likes 0

Dislikes 0

Response

Daniel Grinkevich - Con Ed - Consolidated Edison Co. of New York - 1

Answer

Yes

Document Name

Comment

Likes 0

Question 4

Dislikes 0

Response

Aaron Cavanaugh - Bonneville Power Administration - 1,3,5,6 - WECC

Answer Yes

Document Name

Comment

Likes 0

Dislikes 0

Response

Ann Ivanc - FirstEnergy - FirstEnergy Solutions - 6

Answer Yes

Document Name

Comment

Likes 0

Dislikes 0

Response

Thomas Foltz - AEP - 5

Question 4

Answer	Yes
--------	-----

Document Name	
---------------	--

Comment	
---------	--

--	--

Likes 0	
---------	--

Dislikes 0	
------------	--

Response
----------

--

RoLynda Shumpert - SCANA - South Carolina Electric and Gas Co. - 1,3,5,6 - SERC
---

Answer	Yes
--------	-----

Document Name	
---------------	--

Comment	
---------	--

--	--

Likes 0	
---------	--

Dislikes 0	
------------	--

Response
----------

--

Lauren Price - American Transmission Company, LLC - 1
---

Answer	Yes
--------	-----

Document Name	
---------------	--

Comment	
---------	--

--	--

Question 4

Likes 0

Dislikes 0

Response

Randy Buswell - VELCO -Vermont Electric Power Company, Inc. - 1

Answer Yes

Document Name

Comment

Likes 0

Dislikes 0

Response

Richard Vine - California ISO - 2

Answer

Document Name

Comment

The California ISO supports the joint comments of the ISO/RTO Standards Review Committee

Likes 0

Dislikes 0

Response

Thank you for supporting the comments of the IRC Standards Review Committee (i.e., ISO/RTO Standards Review Committee).



**Question 4**

**Thomas Rafferty - Edison International - Southern California Edison Company - 5**

**Answer**

**Document Name**

**Comment**

Please refer to comments submitted by Robert Blackney on behalf of Southern California Edison

Likes 0

Dislikes 0

**Response**

No comments were submitted.

**Payam Farahbakhsh - Hydro One Networks, Inc. - 1**

**Answer**

**Document Name**

**Comment**

Consistent with our comments above, it should be up to the responsible entity to decide what the appropriate threshold is based on the responsible entities justification, risk assessment, and risk tolerance level. The whitepapers or any other research can be used to support the justification.

Likes 1

Hydro One Networks, Inc., 3, Malozewski Paul

Dislikes 0

**Response**

Thank you for your comment. See response in Q3.

**Rachel Coyne - Texas Reliability Entity, Inc. - 10**

**Answer**

Question 4

Document Name

Comment

Texas RE does not have comments on this question.

Likes 0

Dislikes 0

Response

Question 5

5. The SDT developed proposed Requirement R7 to address FERC directives in Order No. 830 for establishing Corrective Action Plan (CAP) deadlines associated with GMD Vulnerability Assessments (P. 101, 102). Do you agree with the proposed requirement? If you do not agree, or if you agree but have comments or suggestions for the proposed requirement provide your recommendation and explanation.

Thomas Foltz - AEP - 5

Answer No

Document Name

Comment

The language used in R7 needs to clarify the type of “year” used in the deadlines of the CAP. Is this “Calendar Year” or “Calendar Months”? Please clarify. Also, AEP seeks clarification on whether a CAP is required or expected in response to the Thermal Impact Assessments from R6. If it is, then there may be a conflict in the timelines for the execution of R4 and R6 and the timeline for the development of a CAP as per R7.

Likes 0

Dislikes 0

Response

Thank you for your comment. The SDT notes that the use of the term “one year” is sufficiently clear. A CAP is not required for individual transformers that do not meet the requirements of Requirement R6.

Shawn Abrams - Santee Cooper - 1, Group Name Santee Cooper

Answer No

Document Name

Comment

Santee Cooper has concerns that NERC/FERC is in essence directing entities to implement Corrective Action Plans which violates the Energy Policy Act of 2005. This revision of TPL-007 actually has a requirement to implement Corrective Action Plans within a specified period after their development.

Likes 0

Question 5

Dislikes 0

**Response**

Thank you for your comment. The SDT is being responsive to the Standards Authorization Request to include deadlines for the CAP as a requirement in the standard.

**Mike Smith - Manitoba Hydro - 1, Group Name** Manitoba Hydro

**Answer** No

**Document Name**

**Comment**

Manitoba Hydro cannot adopt R7 as is as it violates *The Manitoba Hydro Act*. Manitoba Hydro does not support hard coding the timelines for implementing a corrective action plan in the standard. The timelines are a function of a large number of factors that are out of the control of the Transmission Planner – including securing the necessary resources. Corporate annual capital spending is limited and is prioritized based on a number of factors. Securing funding to protect for a 1/100 year event could have lower associated risks to BES reliability than other projects, meaning timeline discretion for the Transmission Planner to address risks is important.

Likes 0

Dislikes 0

**Response**

Thank you for your comment. The SDT is being responsive to the Standards Authorization Request, where in Order 830, FERC directed NERC “to include a deadline of one year from the completion of the GMD Vulnerability Assessments to complete the development of corrective action plans....[and] to modify Reliability Standard TPL-007-1 to include a two-year deadline after the development of the corrective action plan to complete the implementation of non-hardware mitigation and four-year deadline to complete hardware mitigation.” (FERC Order 830, PP 101-102.) The SDT understands the complexity of implementing the CAP and has addressed the situation where the CAP cannot be completed by the deadline due to conditions beyond the control of the responsible entities (See R7.4).

**Chantal Mazza - Hydro-Québec TransEnergie - 1,2 - NPCC**

**Answer** No

Question 5

**Document Name**

**Comment**

We have concerns that the first time the evaluation of the TPL-007 will take place, the corrective action plans may take more time than the R7 requirements. We agree with the deadlines for the second time the evaluation will be done.

Likes 0

Dislikes 0

**Response**

Thank you for your comment. The SDT is being responsive to the Standards Authorization Request to include deadlines for the CAP as a requirement in the standard. The SDT understands the complexity of implementing the CAP and has addressed the situation where the CAP cannot be completed by the deadline due to conditions beyond the control of the responsible entities (See R7.4).

**Nicolas Turcotte - Hydro-Québec TransEnergie - 1**

**Answer**

No

**Document Name**

**Comment**

We have concerns that the first time the evaluation of the TPL-007 will take place, the corrective action plans may take more time than the R7 requirements. We agree with the deadlines for the second time the evaluation will be done.

Likes 0

Dislikes 0

**Response**

Thank you for your comment. The SDT is being responsive to the Standards Authorization Request to include deadlines for the CAP as a requirement in the standard. The SDT understands the complexity of implementing the CAP and has addressed the situation where the CAP cannot be completed by the deadline due to conditions beyond the control of the responsible entities (See R7.4).

**Karie Barczak - DTE Energy - Detroit Edison Company - 3**

## Question 5

<b>Answer</b>	No
---------------	----

<b>Document Name</b>	
----------------------	--

**Comment**

Will the TO and GO have any input in the selection of the mitigation actions?

Likes	0
-------	---

Dislikes	0
----------	---

**Response**

Thank you for your comment. The SDT expects that the development of the CAP would be a joint effort among the applicable entities. Requirement 7.5.1 provides a feedback loop for those functional entities who are referenced in the CAP.

**Laurie Williams - PNM Resources - Public Service Company of New Mexico - 1**

<b>Answer</b>	No
---------------	----

<b>Document Name</b>	
----------------------	--

**Comment**

There are specific timetable for implementing the CAP and additional administrative burden placed on the responsible entity if the timetable is not met; therefore, an additional requirement should be added to the standard to require any functional entity referenced in a CAP to implement the CAP identified by the responsible entity.

Likes	0
-------	---

Dislikes	0
----------	---

**Response**

Thank you for your comment. An additional requirement is not necessary. The CAP requirements allow for revisions to the CAP if situations beyond the control of the responsible entity prevent the implementation of the CAP within the stated timetable.

**Larisa Loyferman - CenterPoint Energy Houston Electric, LLC - 1 - Texas RE**

<b>Answer</b>	No
---------------	----

Question 5

Document Name

Comment

CenterPoint Energy disagrees with the prescriptive timeframes identified in R7.3.1 and R7.3.2. and recommends eliminating R7.3 in its entirety. Requiring a specific timeframe for mitigation implementation is overly prescriptive and unprecedented for a NERC standard. The specifics of an implementation timeline should be developed by the responsible entities with more intimate knowledge and understanding of their systems. The compliance burden of this requirement does not provide commensurate reliability benefits.

If R7.3 is not eliminated as recommended above, CenterPoint Energy supports R7.4 but recommends that the first sentence of R7.4 be reworded as follows:

R7.4 Be revised if responsible entity cannot implement the CAP within the timetable provided in R7.3.

Likes 0

Dislikes 0

Response

Thank you for your comment. The SDT is being responsive to the Standards Authorization Request to include deadlines for the CAP as a requirement in the standard. The SDT understands the complexity of implementing the CAP and has addressed the situation where the CAP cannot be completed by the deadline due to conditions beyond the control of the responsible entities (See R7.4).

Joshua Eason - Joshua Eason On Behalf of: Michael Puscas, ISO New England, Inc., 2; - Joshua Eason

Answer

No

Document Name

Comment

ISO-NE is supportive of the proposed R7 as long as any delays with implementing a CAP due to tariff requirements for engaging a stakeholder planning process when developing system upgrades associated with a CAP are considered to be “beyond the control of the responsible entity.” Further, ISO-NE is encouraged that the implementation plan for TPL-007-2 includes a one year period between the completion of the vulnerability assessment in R4 and the completion of any needed CAPs according to R7. ISO-NE believes that this is in acknowledgement that the analysis in R4 (and possible in R6) may need to be repeated during the development of CAPs due to the iterative nature of the CAP development process.

## Question 5

Likes 0

Dislikes 0

**Response**

Thank you for your comment. The SDT has added additional language to the end of the “Rationale for Requirement R7.”

**Eric Shaw - Eric Shaw On Behalf of: Lee Maurer, Oncor Electric Delivery, 1; - Eric Shaw**

**Answer** No

**Document Name**

**Comment**

The hardware mitigation timeline mentioned in the requirement R7 does not address the complexities in building the project like regulatory approvals, construction clearances on existing equipment, Right of Way requirements, etc.

Likes 0

Dislikes 0

**Response**

The SDT is responding to a FERC directive in Order 830 to include deadlines for the CAP as a requirement in the standard. The SDT understands the complexity of implementing the CAP and has addressed the situation where the CAP cannot be completed by the deadline due to conditions beyond the control of the responsible entities (See R7.4).

**Donald Lock - Talen Generation, LLC - 5**

**Answer** No

**Document Name**

**Comment**

The four-year hardware implementation deadline in R7.3.2 may be impractical, especially if need for a large number of entities to install GIC blocking devices leads to extended lead-times for this equipment. The same issue was thoroughly investigated by the PRC-025 SDT (see the Implementation Plan for this standard), leading to an 84-months deadline, and we recommend that the TPL-007-2 SDT follow this precedent.



## Question 5

Likes 0

Dislikes 0

**Response**

Thank you for your comment. The SDT is being responsive to the Standards Authorization Request to include deadlines for the CAP as a requirement in the standard. The SDT understands the complexity of implementing the CAP and has addressed the situation where the CAP cannot be completed by the deadline due to conditions beyond the control of the responsible entities (See R7.4).

**Quintin Lee - Eversource Energy - 1****Answer** No**Document Name****Comment**

We agree with the addition of the proposed Requirement R7 to TPL-007-2, however we are concerned with the possible required timeframe for implementation. Determining appropriate mitigations involves iterative evaluations and solutions. The solutions may involve a number of TOs and various stakeholder (ISOs/RTOs, governmental bodies, market participants) input may be required as well. The timing requirements should recognize and allow for delays out of the control of the good-faith effort of the responsible entity. Given that GIC assessment and mitigation is a new topic, it is likely that significant time will be required to achieve regional consensus on the appropriate mitigation plan.

Likes 0

Dislikes 0

**Response**

Thank you for your comment. The SDT is being responsive to the Standards Authorization Request to include deadlines for the CAP as a requirement in the standard. The SDT understands the complexity of implementing the CAP and has addressed the situation where the CAP cannot be completed by the deadline due to conditions beyond the control of the responsible entities (See R7.4).

**David Ramkalawan - Ontario Power Generation Inc. - 5****Answer** No**Document Name**

Question 5

**Comment**

OPG does not agree with the implementation deadlines:

R7.2 provides one year for the CAP; this has not been performed before and the timeline may not be realistic.

As stated in the additional comments:

- The four years deadline to implement all the hardware mitigation action may provide unfair market advantage to the unaffected/ less affected TOP, GOP due to the time/resources/financial effort involved. Continued operation should be allowed if there is a shortage of hardware, or the lead time to design/procure/implement complete hardware solution exceeds the four years duration.
- The two years deadline to implement all the non-hardware solution may provide unfair market advantage to the unaffected/less affected TOP, GOP, as the implementation for a large scale TOP, GOP will take more time, resources/financial effort and may require commissioning and studies.

Likes 0

Dislikes 0

**Response**

Thank you for your comment. It is anticipated that the actual implementation (trigger to activate) of the CAP that includes operational procedure would only occur during a GMD/GIC event of sufficient size as determined by the assessment. Since GMD events are very rare, there is less likelihood that market impacts would occur as compared to a 'regular' transmission outage or constraint not related to GMD mitigation.

The SDT understands the complexity of implementing the CAP and has addressed the situation where the CAP cannot be completed by the deadline due to conditions beyond the control of the responsible entities (See R7.4).

**Brian Van Gheem - ACES Power Marketing - 6 - NA - Not Applicable, Group Name ACES Standards Collaborators**

**Answer**

No

**Document Name**

**Comment**

The revision identifies the need to have implementation of non-hardware and hardware mitigations within two and four years of CAP development, respectively. However, there is no technical guidance within the standard that identifies the difference between these

**Question 5**

mitigations. According to the FERC Order, GIC blocking or monitoring devices are identified as hardware mitigations. Similar references are listed within the NERC Geomagnetic Disturbance Planning Guide. We believe these references should be directly incorporated into the requirement, and replace hardware with GIC reduction or similar devices.

Likes 0

Dislikes 0

**Response**

Thank you for your comment. The standard is not prescriptive in listing the various hardware and non-hardware options. Some hardware and non-hardware options are listed in Requirement R7.1.

**Chris Scanlon - Exelon - 1**

**Answer**

No

**Document Name**

**Comment**

The deadlines specified in R7.3.1 and R7.3.2 are ambiguous. Using the term “development” does not offer a specified date to measure the 2- or 4-year installation requirements. To provide clarity for those needing to implement the mitigation, please consider replacing “development of CAP” with “final approval of CAP by the Planning Coordinator or Transmission Planner.”

R7 does not provide a method to address situations where the responsible entity knows that the selected mitigation cannot meet the 2- or 4-year deadline during the development of the CAP. As the standard currently states, a CAP would need to be developed with the specified deadlines in R7.3 and then immediately revised to address the known situations instead of identifying the appropriate timeline during the development of the CAP. Consider revising R7.4 such that it is not specific to revisions to a CAP only to address these situations.

Likes 0

Dislikes 0

**Response**

**Question 5**

Thank you for your comment. The standard is not prescriptive in providing additional detail to what is essentially an internal process. Entities may each have different internal processes for the issuance of documents.

The SDT understands the complexity of implementing the CAP and has addressed the situation where the CAP cannot be completed by the deadline due to conditions beyond the control of the responsible entities (See R7.4).

**Marty Hostler - Northern California Power Agency - 5**

**Answer** No

**Document Name**

**Comment**

Increased costs do not justify the low, if any, reliability benefits. There should be a threshold of greater than 500 MVA, similar to CIP standards: High, Medium, and Low impact rating criteria.

Likes 0

Dislikes 0

**Response**

Thank you for your comment. Whether a particular transformer is relevant to the reliability of the BES is independent of the size of the transformer and is determined by the entity responsible for the reliability of the BES in that area. The applicability for the TPL-007 standard is to BES transformers that have a high-side wye-grounded connection that is 200 kV and above.

**Sergio Banuelos - Tri-State G and T Association, Inc. - 1,3,5 - MRO,WECC**

**Answer** No

**Document Name**

**Comment**

Tri-State has concern that as written, the TP/PC can create a CAP that the implementing entity (another TO/GO) may have issues with. It seems the TP/PC has ultimate control on what the CAP is without taking into account that the implementing entity may have other thoughts or differing opinions. In a situation where a TO/GO states that they are unable to implement a CAP given to them by another TP/PC, what

## Question 5

recourse does the TP/PC have? If an agreement cannot be reached amongst the planning and implementing entities, then what are the next steps to be taken?

Likes 0

Dislikes 0

**Response**

Thank you for your comment. The SDT expects that the development of the CAP would be a joint effort among the applicable entities. Requirement 7.5.1 provides a feedback loop for those functional entities who are referenced in the CAP.

**Dennis Sismaet - Northern California Power Agency - 6**

**Answer** No

**Document Name**

**Comment**

Increased costs do not justify the low, if any, reliability benefits. There should be a threshold of greater than 500 MVA, similar to CIP standards: High, Medium, and Low impact rating criteria.

Likes 0

Dislikes 0

**Response**

Thank you for your comment. Whether a particular transformer is relevant to the reliability of the BES is independent of the size of the transformer and is determined by the entity responsible for the reliability of the BES in that area. The applicability for the TPL-007 standard is to BES transformers that have a high-side wye-grounded connection that is 200 kV and above.

**Terry Harbour - Berkshire Hathaway Energy - MidAmerican Energy Co. - 1**

**Answer** No

**Document Name**

**Comment**

## Question 5

The NSRF believes a definition/example of what “hardware” means in this context is needed. Order 830 in P 82. Says: *NERC states that Reliability Standard TPL-007-1 contains “requirements to develop the models, studies, and assessments necessary to build a picture of overall GMD vulnerability and identify where mitigation measures may be necessary.” NERC explains that mitigating strategies “may include installation of hardware (e.g., GIC blocking or monitoring devices), equipment upgrades, training, or enhanced Operating Procedures.* Therefore, hardware may only mean GIC blocking or monitoring devices, but it can also include equipment upgrades.

Likes	0
-------	---

Dislikes	0
----------	---

## Response

Thank you for your comment. The standard is not prescriptive in listing the various hardware and non-hardware options. Some hardware and non-hardware options are listed in Requirement R7.1.

sean erickson - Western Area Power Administration - 1

Answer	Yes
--------	-----

Document Name	
---------------	--

## Comment

[TPLTF](#)<sup>11</sup> Discussion: Given the specificity of the Paragraphs 101 and 102 directives of FERC Order No. 830 Paragraph 44, the group believes that the SDT had little flexibility when developing the proposed language of Requirement R7. The group agrees with the proposed Requirement R7, as presented. The group would like to reiterate the suggestion that the Supplemental GMD Event nomenclature be changed to Extreme Value GMD Event, as explained in the group’s discussion of Question Q2.

Likes	0
-------	---

Dislikes	0
----------	---

## Response

---

<sup>11</sup> TPLTF document is found at the end of this document in Attachment 1.

## Question 5

Thank you for supporting the [SPP TPLTF](#) comments<sup>12</sup> on the TPL-007-2 standard. The IMAGE dataset is the most complete and comprehensive data available and is therefore the best data source available to support the development of the standard.

Although the four events mentioned in the Supplemental Geomagnetic Event Description document all occurred in northern latitudes, there is no evidence that the local enhancement effect only occurs in high latitudes. Based on the past experiences with the IMAGE data, it is not expected that the coastal effect has a significant effect on the geomagnetic fields that were used in the extreme value analysis.

**Dana Klem - MRO - 1,2,3,4,5,6 - MRO, Group Name MRO NSRF**

**Answer** Yes

**Document Name**

**Comment**

The NSRF believes a definition/example of what “hardware” means in this context is needed. Order 830 in P 82. Says: *NERC states that Reliability Standard TPL-007-1 contains “requirements to develop the models, studies, and assessments necessary to build a picture of overall GMD vulnerability and identify where mitigation measures may be necessary.” NERC explains that mitigating strategies “may include **installation of hardware (e.g., GIC blocking or monitoring devices)**, equipment upgrades, training, or enhanced Operating Procedures.* Therefore, hardware may only mean GIC blocking or monitoring devices, but it can also include equipment upgrades.

Likes 1 Darnez Gresham, N/A, Gresham Darnez

Dislikes 0

**Response**

Thank you for your comment. The standard is not prescriptive in listing the various hardware and non-hardware options. Some hardware and non-hardware options are listed in Requirement R7.1.

**Neil Swearingen - Salt River Project - 1,3,5,6 - WECC**

**Answer** Yes

<sup>12</sup> TPLTF document is found at the end of this document in Attachment 1.

Question 5

**Document Name**

**Comment**

SRP requests clarification of the phrase "one year" used in 7.2, such as "one calendar year" or "15 months".

Likes 0

Dislikes 0

**Response**

Thank you for your comment. The SDT notes that the use of the term "one year" is sufficiently clear.

**Stephanie Burns - Stephanie Burns On Behalf of: Michael Moltane, International Transmission Company Holdings Corporation, 1; - Stephanie Burns**

**Answer**

Yes

**Document Name**

**Comment**

The deadlines appear to be reasonable (1 year to come up with a CAP when required; 2-years from CAP determination to implement any non-hardware related solutions; 4-years from CAP determination to implement any hardware related solutions; and exceptions for not meeting deadlines for factors beyond the control of the responsible entity)

Likes 0

Dislikes 0

**Response**

Thank you for your comments.

**Shannon Mickens - Southwest Power Pool, Inc. (RTO) - 2 - SPP RE, Group Name SPP Standards Review Group**

**Answer**

Yes

**Document Name**



## Question 5

## Comment

Given the specificity of the Paragraphs 101 and 102 directives of FERC Order No. 830 Paragraph 44, the SPP Standards Review Group believes that the SDT had little flexibility when developing the proposed language of Requirement R7. We agree with the proposed Requirement R7, as presented.

The group would like to reiterate the suggestion that the Supplemental GMD Event nomenclature be changed to Extreme Value GMD Event, as explained in the group's discussion of Question Q2.

Likes	0
-------	---

Dislikes	0
----------	---

## Response

Thank you for supporting the [SPP TPLTF](#) comments<sup>13</sup> on the TPL-007-2 standard. The IMAGE dataset is the most complete and comprehensive data available and is therefore the best data source available to support the development of the standard.

Although the four events mentioned in the Supplemental Geomagnetic Event Description document all occurred in northern latitudes, there is no evidence that the local enhancement effect only occurs in high latitudes. Based on the past experiences with the IMAGE data, it is not expected that the coastal effect has a significant effect on the geomagnetic fields that were used in the extreme value analysis.

**Elizabeth Axson - Electric Reliability Council of Texas, Inc. - 2, Group Name** IRC Standards Review Committee

Answer	Yes
--------	-----

Document Name	
---------------	--

## Comment

IRC agrees with the proposed deadlines as long as any delays with implementing a CAP due to tariff or regional requirements for conducting a stakeholder planning process when developing system upgrades associated with a CAP are considered to be "beyond the control of the responsible entity." Further, IRC is encouraged that the implementation plan for TPL-007-2 includes a one year period between the completion of the vulnerability assessment in R4 and the completion of any needed CAPs according to R7. IRC believes that this is in

<sup>13</sup> TPLTF document is found at the end of this document in Attachment 1.

**Question 5**

acknowledgement that the analysis in R4 (and possibly R6) may need to be repeated during the development of CAPs due to the iterative nature of the CAP development process.

Likes 0

Dislikes 0

**Response**

Thank you for your comment. The SDT has added additional language to the end of the “Rationale for Requirement R7.”

**Randy Buswell - VELCO -Vermont Electric Power Company, Inc. - 1**

**Answer** Yes

**Document Name**

**Comment**

Likes 0

Dislikes 0

**Response**

**Lauren Price - American Transmission Company, LLC - 1**

**Answer** Yes

**Document Name**

**Comment**

Likes 0

Dislikes 0

Question 5

Response

Rolynda Shumpert - SCANA - South Carolina Electric and Gas Co. - 1,3,5,6 - SERC

Answer Yes

Document Name

Comment

Likes 0

Dislikes 0

Response

Ann Ivanc - FirstEnergy - FirstEnergy Solutions - 6

Answer Yes

Document Name

Comment

Likes 0

Dislikes 0

Response

Aaron Cavanaugh - Bonneville Power Administration - 1,3,5,6 - WECC

Answer Yes

Question 5

Document Name

Comment

Likes 0

Dislikes 0

Response

Daniel Grinkevich - Con Ed - Consolidated Edison Co. of New York - 1

Answer

Yes

Document Name

Comment

Likes 0

Dislikes 0

Response

Michael Shaw - Lower Colorado River Authority - 6, Group Name LCRA Compliance

Answer

Yes

Document Name

Comment

Likes 0

Question 5

Dislikes 0

Response

Robert Blackney - Edison International - Southern California Edison Company - 1,3,5,6 - WECC

Answer Yes

Document Name

Comment

Likes 0

Dislikes 0

Response

Gerry Huitt - Xcel Energy, Inc. - 5

Answer Yes

Document Name

Comment

Likes 0

Dislikes 0

Response

Michelle Amarantos - APS - Arizona Public Service Co. - 1

Question 5

Answer	Yes
--------	-----

Document Name	
---------------	--

Comment	
---------	--

--	--

Likes 0	
---------	--

Dislikes 0	
------------	--

**Response**

--	--

**Laura Nelson - IDACORP - Idaho Power Company - 1**

Answer	Yes
--------	-----

Document Name	
---------------	--

Comment	
---------	--

--	--

Likes 0	
---------	--

Dislikes 0	
------------	--

**Response**

--	--

**Jeffrey Watkins - Jeffrey Watkins On Behalf of: Eric Schwarzrock, Berkshire Hathaway - NV Energy, 5; - Jeffrey Watkins**

Answer	Yes
--------	-----

Document Name	
---------------	--

Comment	
---------	--

--	--

Question 5

Likes 0

Dislikes 0

Response

Colby Bellville - Colby Bellville On Behalf of: Dale Goodwine, Duke Energy , 6, 5, 3, 1; - Colby Bellville, Group Name Duke Energy

Answer Yes

Document Name

Comment

Likes 0

Dislikes 0

Response

Payam Farahbakhsh - Hydro One Networks, Inc. - 1

Answer Yes

Document Name

Comment

Likes 1 Hydro One Networks, Inc., 3, Malozewski Paul

Dislikes 0

Response

Question 5

**Glen Farmer - Avista - Avista Corporation - 5**

**Answer** Yes

**Document Name**

**Comment**

Likes 0

Dislikes 0

**Response**

**Douglas Webb - Douglas Webb On Behalf of: Chris Bridges, Great Plains Energy - Kansas City Power and Light Co., 3, 6, 5, 1; Harold Wyble, Great Plains Energy - Kansas City Power and Light Co., 3, 6, 5, 1; James McBee, Great Plains Energy - Kansas City Power and Light Co., 3, 6, 5, 1; Jessica Tucker, Great Plains Energy - Kansas City Power and Light Co., 3, 6, 5, 1; - Douglas Webb**

**Answer** Yes

**Document Name**

**Comment**

Likes 0

Dislikes 0

**Response**

**Pamela Hunter - Southern Company - Southern Company Services, Inc. - 1,3,5,6 - SERC, Group Name Southern Company**

**Answer** Yes



Question 5

Document Name

Comment

Likes 0

Dislikes 0

Response

Ruida Shu - Northeast Power Coordinating Council - 1,2,3,4,5,6,7,8,9,10 - NPCC, Group Name RSC no Hydro One, HQ and IESO

Answer Yes

Document Name

Comment

Likes 0

Dislikes 0

Response

James Anderson - CMS Energy - Consumers Energy Company - 1,3,4,5

Answer Yes

Document Name

Comment

Likes 0

Question 5

Dislikes 0

Response

Michael Buyce - City Utilities of Springfield, Missouri - 1

Answer Yes

Document Name

Comment

Likes 0

Dislikes 0

Response

Rachel Coyne - Texas Reliability Entity, Inc. - 10

Answer

Document Name

Comment

Texas RE acknowledges the SDT made the decision to not require entities have a Corrective Action Plan for the supplemental GMD Vulnerability Assessment if the System does not meet the performance requirements indicated in Attachment 1. Requirement R8 Part 8.3 requires that if the supplemental GMD Vulnerability Assessment concludes there is Cascading, an evaluation of possible actions designed to reduce the likelihood or mitigate the consequences and adverse impacts of the event(s) shall be conducted. Texas RE recommends the responsible entity also conduct an evaluation of possible actions designed to reduce the likelihood or mitigation the consequences and adverse impacts of voltage collapse and uncontrolled islanding.

Likes 0

## Question 5

Dislikes 0

**Response**

Thank you for your comment. The SDT notes that Requirement R8.3 is sufficiently clear.

**Thomas Rafferty - Edison International - Southern California Edison Company - 5**

Answer

Document Name

**Comment**

Please refer to comments submitted by Robert Blackney on behalf of Southern California Edison

Likes 0

Dislikes 0

**Response**

No comments were submitted.

**Richard Vine - California ISO - 2**

Answer

Document Name

**Comment**

The California ISO supports the joint comments of the ISO/RTO Standards Review Committee

Likes 0

Dislikes 0

**Response**

Thank you for supporting the comments of the IRC Standards Review Committee (i.e., ISO/RTO Standards Review Committee).

## Question 6

6. The SDT developed Requirements R11 and R12 to address FERC directives in Order No. 830 for requiring responsible entities to collect GIC monitoring and magnetometer data (P. 88; P. 90-92). Do you agree with the proposed requirements? If you do not agree, or if you agree but have comments or suggestions for the proposed requirements provide your recommendation and explanation.

Terry Harbour - Berkshire Hathaway Energy - MidAmerican Energy Co. - 1

Answer No

Document Name

#### Comment

##### Comment #1:

Modify R11 and R12 to replace “Planning Coordinator Area” with the term “respective area” or “responsible area”. This is consistent with TPL-007-1 and TPL-001-4. See example below:

**R12.** Each responsible entity, as determined in Requirement R1, shall implement a process to obtain geomagnetic field data for its respective Planning Coordinator’s planning area.

##### Comment #2:

NSRF believes that the reference to “GMD measurement data” in R1 should be changed to align with the language in requirements R11 and R12. The term GMD measurement data is general and could be interpreted to include data that is outside the scope of the standard. The NSRF suggest the following changes to R1:

R1. Each Planning Coordinator, in conjunction with its Transmission Planner(s), shall identify the individual and joint responsibilities of the Planning Coordinator and Transmission Planner(s) in the Planning Coordinator’s planning area for maintaining models, performing the study or studies needed to complete benchmark and supplemental GMD Vulnerability Assessments, and implementing process(es) to obtain GIC monitor data and geomagnetic field data GMD measurement data as specified in this standard.

Likes 0

Dislikes 0

#### Response

Thank you for your comment.

## Question 6

#1. The SDT considers the Planning Coordinators to be the most applicable entity, covering the appropriate area, for implementing processes related to Requirements R11 and R12 to obtain GIC monitor data from at least one GIC monitor and geomagnetic field data, respectively.

#2. The benchmark and supplemental GMD vulnerability assessments in Requirement R1 refers to Requirements R4-R7 and R8-R10, respectively, while the GMD measurement data refers to Requirements R11-R12, i.e., GMD monitor data and geomagnetic field data. The SDT has added text in the Rationale for Requirements R11 and R12 that GMD measurement data refers to GMD monitor data and geomagnetic field data.

**Dennis Sismaet - Northern California Power Agency - 6**

<b>Answer</b>	No
---------------	----

<b>Document Name</b>	
----------------------	--

**Comment**

Increased costs do not justify the low, if any, reliability benefits

Likes	0
-------	---

Dislikes	0
----------	---

**Response**

Thank you for your comment. The SDT believes that the requirements to implement processes to obtain GIC monitor data and geomagnetic field data are needed for model validation. The SDT is being responsive to the Standards Authorization Request.

**Marty Hostler - Northern California Power Agency - 5**

<b>Answer</b>	No
---------------	----

<b>Document Name</b>	
----------------------	--

**Comment**

Increased costs do not justify the low, if any, reliability benefits.

Likes	0
-------	---

## Question 6

Dislikes 0

**Response**

Thank you for your comment. The SDT believes that the requirements to implement processes to obtain GIC monitor data and geomagnetic field data are needed for model validation. The SDT is being responsive to the Standards Authorization Request.

**Chris Scanlon - Exelon - 1****Answer**

No

**Document Name****Comment**

The Rationale section for R11 and R12 and the Application Guidelines section for R11 include a statement about using Hall Effect transducers on the transformer neutrals. There are many technically correct approaches for monitoring geomagnetically induced currents and the standard should not inadvertently advocate for one method of monitoring over another. The statement should be removed and if necessary, include a reference to IEEE C57.163 which discusses monitoring.

The R11 and R12 rationale section makes reference to the terms “geomagnetic field data” and “geomagnetic field data product”. What is the difference? The term “product” should be clarified.

Likes 0

Dislikes 0

**Response**

Thank you for your comment. The rationale box is intended to provide guidance and not to necessarily advocate a particular method. The phrase “geomagnetic field data product” is an estimate of the geomagnetic field for a particular geographic location.

**Brian Van Gheem - ACES Power Marketing - 6 - NA - Not Applicable, Group Name ACES Standards Collaborators****Answer**

No

**Document Name****Comment**

**Question 6**

1. We believe the requirements should clarify expected processes once GIC monitoring and magnetometer data is collected. Are responsible entities expected to include this information in their models that are required for Requirement R2? Are they expected to provide this information to their Reliability Coordinator for inclusion in its GMD Operating Plan in NERC Reliability Standard EOP-010-1? We believe the associated FERC directives could be incorporated into Requirement R1, which already requires an entity-coordinated process to identify the collection of GMD data measurements. We see benefits in enhancing Requirement R1 to include subparts for maintaining models, performing studies for GMD Vulnerability Assessments, and GIC monitoring and magnetometer data collection, including within its associated Violation Severity Limits.
2. The reference to the collection of data for the entire Planning Coordination Area is too broad and burdensome for the applicability of these requirements. We believe the identified collection area should be reflective of the applicability, to that of the responsible entity's planning area.

Likes 0

Dislikes 0

**Response**

Thank you for your comment.

1. The SDT is being responsive to the Standards Authorization Request to collect geomagnetically induced current monitoring and magnetometer data as necessary to enable model validation and situational awareness. The commenter is suggesting changes to EOP-010-1, which is an existing standard and outside the scope of the SAR.
2. The SDT considers the Planning Coordinators to be the most applicable entity, covering the appropriate area, for implementing processes related to requirements R11 and R12 to obtain GIC monitor data from at least one GIC monitor and geomagnetic field data.

**Pamela Hunter - Southern Company - Southern Company Services, Inc. - 1,3,5,6 - SERC, Group Name Southern Company**

**Answer**

No

**Document Name**

**Comment**

1. Paragraph 2, page 11 of 42 of proposed TPL-007-2, under GMD Measurement Data Process (blue box) – the Drafting Team states that “ Technical considerations for GIC monitoring are contained in Chapter 6 of the 2012 Special Reliability...” This information is

## Question 6

contained in Chapter 9 and not in Chapter 6 of the Interim Report. Please update this section as well as the first sentence immediately under R11 in page 38 of 42. In addition, we recommend that the Drafting Team includes a link to the report as it is difficult to find.

2. Requirement 12, page 12 or 42, requires that “Each responsible entity...shall implement a process to obtain geomagnetic field data for its Planning Coordinator’s planning area.” This requirement appears to be in direct contradiction to the last sentence contained inside the ‘blue box’ same page; which states: “The geomagnetic field data product does not need to be derived from a magnetometer or observatory within the Planning Coordinator’s planning area”. We request clarification. And, if the magnetometer data needs to be extrapolated, we recommend that the drafting team provides guidance.
3. Draft 1 of TPL-007-2, page 38 of 42, under Monitor specifications –
  - i. monitor data range (i.e., -500 A to +500 A CT), will this monitor specification be a recommendation or requirement? We recommend the Drafting Team to provide clarification. Note this section references the NERC 2012 GMD report and in the 2012 report it is stated “The DC sensor should accommodate at least +/- 500 amps of DC current...”. Referencing the 2012 GMD Report creates confusion.
  - ii. ambient temperature ratings, we recommend the SDT to provide clarification; i.e., does the monitor need to include the ability to measure ambient temperature and should we log the station ambient temperatures.

Likes 0

Dislikes 0

## Response

Thank you for your comment.

1. The SDT would like to express our thanks for pointing out the typo in the rationale box for requirements R11 and R12 with respect to chapter number in the 2012 Special Reliability Assessment Interim Report: Effects of Geomagnetic Disturbances on the Bulk-Power System (NERC 2012 GMD Report).
2. The SDT considers the Planning Coordinators to be the most applicable entity, covering the appropriate area, for implementing processes related to requirements R11 and R12 to obtain GIC monitor data from at least one GIC monitor and geomagnetic field data. The phrase “geomagnetic field data product” is an estimate of the geomagnetic field for a particular geographic location. The standard allows flexibility to collect the geomagnetic field data or use the geomagnetic field data product to obtain the data as necessary.
3. The text in the Guidelines and Technical Basis related to requirement R11, which refers to the technical considerations for GIC monitoring based on the NERC 2012 GMD Report [Chapter 9] as well as the Intermagnet Technical Reference Manual, provides



## Question 6

guidelines and recommendations that are not part of the TPL-007-2 requirements. The “monitor” specifications only need to consider the ambient ratings of the monitoring equipment based on their location.

**Jeffrey Watkins - Jeffrey Watkins On Behalf of: Eric Schwarzrock, Berkshire Hathaway - NV Energy, 5; - Jeffrey Watkins**

**Answer** No

**Document Name**

**Comment**

Depending on the size of the planning area, one GIC and magnetometer value may not provide sufficient data to accurately provide model validation. Some additional guidance would also be helpful for determining where to place monitoring equipment so that the equipment is installed in a location that can provide meaningful data. NV Energy would prefer the SDT consider adding additional details on determining the placement of equipment and consider adding detail to add more than one monitoring equipment when appropriate.

R11 and R12 requires data to be collected, but does not require anything to be done with the data. With no requirement to do anything with data collected, it seems like these two requirements place an unnecessary task on entities. Additionally, R12 allows entities to collect geomagnetic from sources such as observatories operated by the US Geological Survey. With no requirements to do anything with the data, R12 is asking entities to log onto a website and periodically collect data. NV Energy would like to see these standards expanded upon to require this data to be collected and then used for GMD model validation.

Likes 0

Dislikes 0

**Response**

Thank you for your comment. The SDT is being responsive to the Standards Authorization Request to require responsible entities to collect geomagnetically induced current monitoring and magnetometer data as necessary to enable model validation and situational awareness. The NERC 2012 GMD Report and the Intermagnet Technical Reference Manual provide considerations for developing a process to obtain GIC monitor data and are summarized under Requirement R11 in the Guidelines and Technical Basis section of the TPL-007-2 standard.

**Eric Shaw - Eric Shaw On Behalf of: Lee Maurer, Oncor Electric Delivery, 1; - Eric Shaw**

**Answer** No

**Document Name**

## Question 6

## Comment

One GIC monitor and magnetometer value in the Planning Coordinator's planning area does not provide enough data to enable model validation and situational awareness

Likes 0

Dislikes 0

## Response

Thank you for your comment. The SDT considers the Planning Coordinators to be the most applicable entity, covering the appropriate area, for implementing processes related to requirements R11 and R12 to obtain GIC monitor data from at least one GIC monitor and geomagnetic field data.

**Nicolas Turcotte - Hydro-Québec TransEnergie - 1**

Answer

No

Document Name

## Comment

Magnetometers data are already available from Natural Resources Canada and from Universities research groups, therefore, there is no need to collect them.

In the control room, Hydro-Quebec monitors and collects the impact of GMDs by using voltage distortion level. GIC currents are also collected at different location on the network but they are not used in the control room. The acquisition of these data should be added to the EOP-010-1 reliability standard under the RC supervision and the RC shall transmit them as requested by the PC.

Hydro-Quebec supports initiatives that can be used to monitor and validate, with real measures, the GMD's impact on the network.

Likes 0

Dislikes 0

## Response

Thank you for your comment. As described in the Rationale Box (blue box) on Rationale for Requirements R11 and R12, sources of geomagnetic field data include: Observatories such as those operated by U.S. Geological Survey, Natural Resources Canada, research

## Question 6

organizations, or university research facilities; Installed magnetometers; and Commercial or third-party sources of geomagnetic field data. The SDT is being responsive to the Standards Authorization Request. The comment is suggesting changes to EOP-010-1, which is an existing standard and outside the scope of the SAR.

**Neil Swearingen - Salt River Project - 1,3,5,6 - WECC**

<b>Answer</b>	No
---------------	----

<b>Document Name</b>	
----------------------	--

**Comment**

SRP supports AZPS's response to question 6.

Likes	0
-------	---

Dislikes	0
----------	---

**Response**

Thank you for your comment. Since the GIC monitoring data collection requirement is to have at least one GIC monitor located in the Planning Coordinator's planning area, and not each transmission owner being required to collect GIC monitoring data, the SDT does not believe the exemption from the GIC monitoring data collection requirement discussed in Paragraph 91 of FERC Order No. 830 is applicable. The SDT considers the Planning Coordinators to be the most applicable entity, covering the appropriate area, for implementing processes related to requirements R11 and R12 to obtain GIC monitor data from at least one GIC monitor and geomagnetic field data, and hence the SDT sees no need for a threshold. The SDT supports use of different thresholds for the benchmark and the supplemental GMD Vulnerability Assessments. The collection of GIC monitor data and geomagnetic field data per Requirements R11 and R12 provide a basis for enabling model validation and situational awareness, as discussed in FERC order 830. As such, GIC data collection is necessary regardless of any GIC threshold.

**Chantal Mazza - Hydro-Québec TransEnergie - 1,2 - NPCC**

<b>Answer</b>	No
---------------	----

<b>Document Name</b>	
----------------------	--

**Comment**

## Question 6

Magnetometers data are already available from Natural Resources Canada and from Universities research groups, therefore, there is no need to collect them.

In the control room, Hydro-Quebec monitors and collects the impact of GMDs by using voltage distortion level. GIC currents are also collected at different location on the network but they are not used in the control room. The acquisition of these data should be added to the EOP-010-1 reliability standard under the RC supervision and the RC shall transmit them as requested by the PC.

Hydro-Quebec supports initiatives that can be used to monitor and validate, with real measures, the GMD's impact on the network.

Likes	0
-------	---

Dislikes	0
----------	---

## Response

Thank you for your comment. As described in the Rationale Box (blue box) on Rationale for Requirements R11 and R12, sources of geomagnetic field data include: Observatories such as those operated by U.S. Geological Survey, Natural Resources Canada, research organizations, or university research facilities; Installed magnetometers; and Commercial or third-party sources of geomagnetic field data. The SDT is being responsive to the Standards Authorization Request. The comment is suggesting changes to EOP-010-1, which is an existing standard and outside the scope of the SAR.

**Michelle Amarantos - APS - Arizona Public Service Co. - 1**

Answer	No
--------	----

Document Name	
---------------	--

## Comment

Per Paragraph 91 of FERC Order No. 830, a transmission owner should be able to apply for an exemption from the GIC monitoring data collection requirement if it demonstrates that no or little value would be added to Planning and Operations. The capability to request such exemption is not, however, clearly indicated within Requirements R11 and R12. AZPS respectfully recommends that such language be included.

AZPS further recommends that the SDT utilize language similar to that included in Requirement R10, which includes language that limits the need to [conduct a supplemental thermal impact assessment for applicable BES power transformers where the maximum effective GIC value provided in R9, Part 9.1 is 85 A per phase or greater]. AZPS proposes that similar language be added in Requirements R11 and R12 so that these requirements only apply where the maximum effective GIC value of applicable BES power transformers provided in R9, Part 9.1 is 85 A

**Question 6**

per phase or greater. Such would ensure that the same operational threshold is applied throughout these related requirements, providing consistency and an established threshold for determining need from the operational/planning perspective. Additionally, as noted in AZPS’s comments to question 3 above, AZPS’s request here is primarily for consistency and, while it recommends a threshold of 85 A per phase or greater, its recommendation could be achieved through the consistent application of that value or the 75 A per phase or greater.

Likes 0

Dislikes 0

**Response**

Thank you for your comment. Since the GIC monitoring data collection requirement is to have at least one GIC monitor located in the Planning Coordinator's planning area, and not each transmission owner being required to collect GIC monitoring data, the SDT does not believe the exemption from the GIC monitoring data collection requirement discussed in Paragraph 91 of FERC Order No. 830 is applicable. The SDT considers the Planning Coordinators to be the most applicable entity, covering the appropriate area, for implementing processes related to requirements R11 and R12 to obtain GIC monitor data from at least one GIC monitor and geomagnetic field data, and hence the SDT sees no need for a threshold. The SDT supports use of different thresholds for the benchmark and the supplemental GMD Vulnerability Assessments. The collection of GIC monitor data and geomagnetic field data per Requirements R11 and R12 provide a basis for enabling model validation and situational awareness, as discussed in FERC order 830. As such, GIC data collection is necessary regardless of any GIC threshold. Different screening thresholds were selected because benchmark and supplemental benchmark waveforms are different and their effects on transformers are different. The temperature thresholds are consistent, i.e., the thermal effects on a transformer are characterized by peak temperatures.

**Mike Smith - Manitoba Hydro - 1, Group Name Manitoba Hydro**

**Answer**

No

**Document Name**

**Comment**

It’s nice to collect data but there’s no requirement to do anything with the data, like perform model benchmarking. Collecting data from a single transformer and a single magnetometer may be insufficient to perform any reasonable benchmarking of GMD models. Perhaps this

**Question 6**

could be written in a style closer to MOD-033, for GMD model validation. The Transmission Planner would document their model validation process.

Likes 0

Dislikes 0

**Response**

Thank you for your comment. The SDT is being responsive to the Standards Authorization Request to collect geomagnetically induced current monitoring and magnetometer data as necessary to enable model validation and situational awareness. The NERC 2012 GMD Report and the Intermagnet Technical Reference Manual provide considerations for developing a process to obtain GIC monitor data and are summarized under Requirement R11 in the Guidelines and Technical Basis section of the TPL-007-2 standard.

**Michael Shaw - Lower Colorado River Authority - 6, Group Name LCRA Compliance**

**Answer** No

**Document Name**

**Comment**

The SDT should consider additional details on placement of the monitoring equipment to help guide the installations, similar to PRC-002 and DME. Or, the responsibility for equipment placement guidelines could be delegated (assigned) to the PC to develop at a more local level. Having wide-open equipment monitoring requirements may lead to a lot of wasted investment or inefficient monitoring.

Likes 0

Dislikes 0

**Response**

Thank you for your comment. Technical considerations for GIC monitoring are contained in the NERC 2012 GMD Report as well as the Intermagnet Technical Reference Manual provide considerations to address during the development of a process for obtaining GIC monitor are provided under Requirement R11 in the Guidelines and Technical Basis section.

**Thomas Foltz - AEP - 5**

**Answer** No

Question 6

**Document Name**

**Comment**

American Electric Power does not believe R11 and R12 are explicitly clear in their intent, or state exactly who is required to meet the obligations. The latter may perhaps be inferred by R1, however AEP requests clarity and specificity within R11 and R12 themselves.

Likes 0

Dislikes 0

**Response**

Thank you for your comment. The SDT is being responsive to the Standards Authorization Request to develop revisions to the standard to require responsible entities to collect geomagnetically induced current monitoring and magnetometer data as necessary to enable model validation and situational awareness.

The NERC 2012 GMD Report and the Intermagnet Technical Reference Manual provide considerations for developing a process to obtain GIC monitor data and are summarized under Requirement R11 in the Guidelines and Technical Basis section of the TPL-007-2 standard.

The individual or joint responsibilities of the applicable entities are defined per Requirement R1.

**Shannon Mickens - Southwest Power Pool, Inc. (RTO) - 2 - SPP RE, Group Name SPP Standards Review Group**

**Answer**

Yes

**Document Name**

**Comment**

Despite the added cost to implement additional monitoring and data collection, the SPP Standards Review Group agrees that the SDT developed a reasonable approach to the FERC directives in Order No. 830 Paragraph 88.

Likes 0

Dislikes 0

**Response**

Thank you for your comment.

## Question 6

**Stephanie Burns - Stephanie Burns On Behalf of: Michael Moltane, International Transmission Company Holdings Corporation, 1; - Stephanie Burns**

**Answer** Yes

**Document Name**

**Comment**

FERC required additional data for model validation and situational awareness purposes. The SDT developed requirements allow for the collection of GIC data and magnetometer data (which could come from existing monitoring equipment where available and appropriate) as opposed to necessarily mandating installation of new equipment to obtain the specified data. Responsible entities can thus partner with government agencies or research facilities that operate magnetometers to obtain some of the required data.

Likes 0

Dislikes 0

**Response**

Thank you for your comment.

**Larisa Loyferman - CenterPoint Energy Houston Electric, LLC - 1 - Texas RE**

**Answer** Yes

**Document Name**

**Comment**

CenterPoint Energy agrees with the proposed requirement as written. Furthermore, CenterPoint Energy supports the Commission's determination in P. 92 that requiring data rather than requiring installation of GIC monitors and magnetometers affords greater flexibility while still obtaining benefits. However CenterPoint Energy would not support any revisions that would require installation of devices or the release of entity's protected information.

Likes 0

Dislikes 0



## Question 6

## Response

Thank you for your comment.

**Karie Barczak - DTE Energy - Detroit Edison Company - 3**

**Answer**

Yes

**Document Name**

## Comment

Will this result in a directive for a GO or TO to install GIC monitoring, or will the responsible entity simply get data from existing monitors in its area?

Likes 0

Dislikes 0

## Response

Thank you for your comment. The individual or joint responsibilities of the applicable entities are defined in Requirement R1 and a process to obtain GIC monitor data in Requirement R11.

**Dana Klem - MRO - 1,2,3,4,5,6 - MRO, Group Name MRO NSRF**

**Answer**

Yes

**Document Name**

## Comment

## Comment #1:

Modify R11 and R12 to replace "Planning Coordinator Area" with the term "respective area" or "responsible area". This is consistent with TPL-007-1 and TPL-001-4. See example below:

**R12.** Each responsible entity, as determined in Requirement R1, shall implement a process to obtain geomagnetic field data for its respective Planning Coordinator's planning area.

## Comment #2:

## Question 6

NSFR believes that the reference to “GMD measurement data” in R1 should be changed to align with the language in requirements R11 and R12. The term GMD measurement data is general and could be interpreted to include data that is outside the scope of the standard. The NSRF suggest the following changes to R1:

R1. Each Planning Coordinator, in conjunction with its Transmission Planner(s), shall identify the individual and joint responsibilities of the Planning Coordinator and Transmission Planner(s) in the Planning Coordinator’s planning area for maintaining models, performing the study or studies needed to complete benchmark and supplemental GMD Vulnerability Assessments, and implementing process(es) to obtain GIC monitor data and geomagnetic field data GMD measurement data as specified in this standard.

Likes	1	Darnez Gresham, N/A, Gresham Darnez
-------	---	-------------------------------------

Dislikes	0	
----------	---	--

## Response

Thank you for your comment.

#1. The SDT considers the Planning Coordinator’s planning area to be the most appropriate area for implementing processes related to Requirements R11 and R12 to obtain GIC monitor data from at least one GIC monitor and geomagnetic field data, respectively.

#2. Requirement R1 is sufficiently clear. The benchmark and supplemental GMD vulnerability assessments in Requirement R1 refers to Requirements R4-R7 and R8-R10, respectively, while the GMD measurement data refers to Requirements R11-R12, i.e., GIC monitor data and geomagnetic field data. The SDT has added text in the Rationale for Requirements R11 and R12 that GMD measurement data refers to GIC monitor data and geomagnetic field data.

## Laura Nelson - IDACORP - Idaho Power Company - 1

Answer	Yes
--------	-----

Document Name	
---------------	--

## Comment

In R12, it is not clear how much geomagnetic field data, from a time & space perspective, the responsible entity would be required to obtain for its Planning Coordinator Planning Area.

Question 6

Likes 0

Dislikes 0

**Response**

Thank you for your comment. Requirement R12 does not specify how geomagnetic field data is to be collected from a time and space perspective. The individual or joint responsibilities of the applicable entities are defined in Requirement R1, including responsibilities related to implementation of a process for obtaining geomagnetic field data in Requirement R12.

**sean erickson - Western Area Power Administration - 1**

**Answer** Yes

**Document Name**

**Comment**

[TPLTF](#)<sup>14</sup> Discussion: Despite the added cost to implement additional monitoring and data collection, the group agrees that the SDT developed a reasonable approach to the FERC directives in Order No. 830 Paragraph 88.

Likes 0

Dislikes 0

**Response**

Thank you for your comment.

**Lauren Price - American Transmission Company, LLC - 1**

**Answer** Yes

**Document Name**

**Comment**

<sup>14</sup> TPLTF document is found at the end of this document in Attachment 1.

**Question 6**

This will help refine future assessment requirements as to how applicable the Benchmark and Supplemental Event screening criteria are in comparison compared to actual recorded GMD events.

Likes 0

Dislikes 0

**Response**

Thank you for your comment.

**William Harris - Foundation for Resilient Societies - 8**

**Answer** Yes

**Document Name**

**Comment**

Likes 0

Dislikes 0

**Response**

**Sergio Banuelos - Tri-State G and T Association, Inc. - 1,3,5 - MRO,WECC**

**Answer** Yes

**Document Name**

**Comment**

Likes 0

Dislikes 0

Question 6

Response

Elizabeth Axson - Electric Reliability Council of Texas, Inc. - 2, Group Name IRC Standards Review Committee

Answer Yes

Document Name

Comment

Likes 0

Dislikes 0

Response

Michael Buyce - City Utilities of Springfield, Missouri - 1

Answer Yes

Document Name

Comment

Likes 0

Dislikes 0

Response

James Anderson - CMS Energy - Consumers Energy Company - 1,3,4,5

Answer Yes

Question 6

Document Name

Comment

Likes 0

Dislikes 0

Response

Ruida Shu - Northeast Power Coordinating Council - 1,2,3,4,5,6,7,8,9,10 - NPCC, Group Name RSC no Hydro One, HQ and IESO

Answer

Yes

Document Name

Comment

Likes 0

Dislikes 0

Response

David Ramkalawan - Ontario Power Generation Inc. - 5

Answer

Yes

Document Name

Comment

Likes 0

Question 6

Dislikes 0

Response

Quintin Lee - Eversource Energy - 1

Answer Yes

Document Name

Comment

Likes 0

Dislikes 0

Response

Douglas Webb - Douglas Webb On Behalf of: Chris Bridges, Great Plains Energy - Kansas City Power and Light Co., 3, 6, 5, 1; Harold Wyble, Great Plains Energy - Kansas City Power and Light Co., 3, 6, 5, 1; James McBee, Great Plains Energy - Kansas City Power and Light Co., 3, 6, 5, 1; Jessica Tucker, Great Plains Energy - Kansas City Power and Light Co., 3, 6, 5, 1; - Douglas Webb

Answer Yes

Document Name

Comment

Likes 0

Dislikes 0

Response

Question 6

**Donald Lock - Talen Generation, LLC - 5**

Answer Yes

Document Name

Comment

Likes 0

Dislikes 0

Response

**Glen Farmer - Avista - Avista Corporation - 5**

Answer Yes

Document Name

Comment

Likes 0

Dislikes 0

Response

**Payam Farahbakhsh - Hydro One Networks, Inc. - 1**

Answer Yes

Document Name



Question 6

Comment

Likes 1 Hydro One Networks, Inc., 3, Malozewski Paul

Dislikes 0

Response

Joshua Eason - Joshua Eason On Behalf of: Michael Puscas, ISO New England, Inc., 2; - Joshua Eason

Answer Yes

Document Name

Comment

Likes 0

Dislikes 0

Response

Laurie Williams - PNM Resources - Public Service Company of New Mexico - 1

Answer Yes

Document Name

Comment

Likes 0

Dislikes 0

**Question 6**

**Response**

**Gerry Huitt - Xcel Energy, Inc. - 5**

**Answer** Yes

**Document Name**

**Comment**

Likes 0

Dislikes 0

**Response**

**Robert Blackney - Edison International - Southern California Edison Company - 1,3,5,6 - WECC**

**Answer** Yes

**Document Name**

**Comment**

Likes 0

Dislikes 0

**Response**

**Daniel Grinkevich - Con Ed - Consolidated Edison Co. of New York - 1**

**Answer** Yes

Question 6

Document Name

Comment

Likes 0

Dislikes 0

Response

Aaron Cavanaugh - Bonneville Power Administration - 1,3,5,6 - WECC

Answer

Yes

Document Name

Comment

Likes 0

Dislikes 0

Response

Ann Ivanc - FirstEnergy - FirstEnergy Solutions - 6

Answer

Yes

Document Name

Comment

Likes 0

Question 6

Dislikes 0

Response

RoLynda Shumpert - SCANA - South Carolina Electric and Gas Co. - 1,3,5,6 - SERC

Answer Yes

Document Name

Comment

Likes 0

Dislikes 0

Response

Randy Buswell - VELCO -Vermont Electric Power Company, Inc. - 1

Answer Yes

Document Name

Comment

Likes 0

Dislikes 0

Response

Richard Vine - California ISO - 2

Question 6

Answer

Document Name

Comment

The California ISO supports the joint comments of the ISO/RTO Standards Review Committee

Likes 0

Dislikes 0

Response

Thank you for supporting the comments of the IRC Standards Review Committee (i.e., ISO/RTO Standards Review Committee).

**Thomas Rafferty - Edison International - Southern California Edison Company - 5**

Answer

Document Name

Comment

Please refer to comments submitted by Robert Blackney on behalf of Southern California Edison

Likes 0

Dislikes 0

Response

No comments were submitted.

**Brandon McCormick - Brandon McCormick On Behalf of: Carol Chinn, Florida Municipal Power Agency, 5, 6, 4, 3; David Schumann, Florida Municipal Power Agency, 5, 6, 4, 3; Ginny Beigel, City of Vero Beach, 3; Jeffrey Partington, Keys Energy Services, 4; Joe McKinney, Florida Municipal Power Agency, 5, 6, 4, 3; Mike Blough, Kissimmee Utility Authority, 5, 3; Richard Montgomery, Florida Municipal Power Agency, 5, 6, 4, 3; Tom Reedy, Florida Municipal Power Pool, 6; - Brandon McCormick, Group Name FMPA**

Answer

## Question 6

## Document Name

## Comment

We appreciate the SDT effort to satisfy the requirement of FERC Order No. 830 for the collection of GIC and Magnetometer Data. Currently, R11 and R12 only say to collect the data. We would encourage the drafting team to add language to R11 and R12 that the process document developed by the responsible entity point to the amount of data required, who collects it, who to give it to, and how long to maintain it.

Likes 0

Dislikes 0

## Response

Thank you for your comment. The individual or joint responsibilities of the applicable entities are defined in Requirement R1 and to implement a process for obtaining GIC monitoring data and geomagnetic field data in Requirements R11 and R12, respectively.

## Rachel Coyne - Texas Reliability Entity, Inc. - 10

## Answer

## Document Name

## Comment

Since the Rationale for Requirements R11 and R12 use the term “as necessary”, Texas RE recommends adding the term “as necessary” as a periodicity to the language of Requirements R11 and R12.

Requirement R11 requires a GIC monitor located in the Planning Coordinator’s planning area. The map showing the USGS observatories (<https://geomag.usgs.gov/monitoring/observatories/>) indicates that there is not a USGS monitor in each PC’s planning area. There may be monitoring data available for GIC in the PC’s planning area that is not located within the planning area. Texas RE recommends revising the language to say “Each responsible entity.....from at least one GIC monitor that is monitoring equipment within the Planning Coordinator’s planning area for each earth model represented.....”.

Likes 0

Dislikes 0

## Question 6

**Response**

Thank you for your comment. The SDT is being responsive to the Standards Authorization Request to require responsible entities to collect geomagnetically induced current monitoring and magnetometer data as necessary to enable model validation and situational awareness.

The standard requires data to be obtained from at least one GIC monitor located in the Planning Coordinator's planning area or other part of the system included in the Planning Coordinator's GIC System model (Requirement R11) and geomagnetic field data for its Planning Coordinator's planning area (Requirement R12).

**Question 7**

**7. Do you agree with the proposed Implementation Plan for TPL-007-2? If you do not agree, or if you agree but have comments or suggestions for the Implementation Plan provide your recommendation and explanation.**

**Kristine Ward - Seminole Electric Cooperative, Inc. - 1,3,4,5,6 - FRCC**

**Answer** No

**Document Name**

**Comment**

Comments: The effective date of the revised Standard being only 3 months after FERC's approval is too short. There is no need to rush this new Standard as there are substantial revisions. Seminole recommends a minimum of 12 months after approval

Likes 0

Dislikes 0

**Response**

Thank you for your comment. The SDT has revised the Implementation Plan based on comments received. See the revised Implementation Plan.

**Mike Smith - Manitoba Hydro - 1, Group Name Manitoba Hydro**

**Answer** No

**Document Name**

**Comment**

There should be trial period for industry to gain understanding and knowledge of GMD before implementing a standard.

Likes 0

Dislikes 0

**Response**



## Question 7

Thank you for your comment. The existing standard is already approved and the SDT is being responsive to the Standards Authorization Request. Requiring a trial period is outside the scope of this SDT.

**Michelle Amarantos - APS - Arizona Public Service Co. - 1**

**Answer** No

**Document Name**

**Comment**

AZPS requests more clarity regarding the due date of the supplemental assessment (TPL-007-2 Requirement R8). If the effective date of TPL-007-2 is before the January 1, 2021 and the studies are performed concurrently, what is the due date of the supplemental assessment (TPL-007-2 Requirement R8)? According to the implementation plan, both assessments would be due 42 months after the effective date of TPL-007-2. If such is an accurate statement of the appropriate study deadlines, AZPS requests that the SDT clarify this in its guidance, FAQs, or other document.

Likes 0

Dislikes 0

**Response**

Thank you for your comment. The SDT has revised the Implementation Plan based on comments received. See the revised Implementation Plan.

**Chantal Mazza - Hydro-Québec TransEnergie - 1,2 - NPCC**

**Answer** No

**Document Name**

**Comment**

See comments for Question 1.

Likes 0

Dislikes 0

## Question 7

**Response**

Thank you for your comment, see response in Q1.

**Laura Nelson - IDACORP - Idaho Power Company - 1**

**Answer**

No

**Document Name**

**Comment**

It is not clear why there is a difference in compliance implementation dates for the various requirements between the two Implementation Plan options. It would seem logical that they both would have the same compliance implementation date with respect to the effective date of the Standard.

There does not appear to be a compliance date for R6 if TPL-007-2 becomes effective on or after January 1, 2021.

TPL-007-1 has a compliance date for R5 on January 1, 2019. It is not clear what this date would be if the new standard becomes effective before that date.

Likes 0

Dislikes 0

**Response**

Thank you for your comment. The SDT has revised the Implementation Plan based on comments received. See the revised Implementation Plan.

**Nicolas Turcotte - Hydro-Québec TransEnergie - 1**

**Answer**

No

**Document Name**

**Comment**

See comments for Question 1.

Likes 0

Question 7

Dislikes 0

Response

Laurie Williams - PNM Resources - Public Service Company of New Mexico - 1

Answer No

Document Name

Comment

The current implementation plan doesn't contain an implementation date for R1 which implies an effective date of the first day of the first calendar quarter that is three month after FERC approval. Planning Coordinators will need time to update their document identifying individual and joint responsibility to include the supplemental GMD Vulnerability Assessment and a process to obtain GMD measurement data. Entities should be given a minimum of 6 months after the approval of the standard to update R1 documentation since it does require coordination with Transmission Planners.

Likes 0

Dislikes 0

Response

Thank you for your comment. The SDT has revised the Implementation Plan based on comments received. See the revised Implementation Plan.

Larisa Loyferman - CenterPoint Energy Houston Electric, LLC - 1 - Texas RE

Answer No

Document Name

Comment

## Question 7

CenterPoint Energy disagrees with the proposed Implementation Plan for TPL-007-2. CenterPoint Energy recommends delaying the implementation of Requirement 8 through 10 until after one complete cycle of Requirements R4 through R6. CenterPoint Energy's recommendation is based on the following:

- The efforts already required for compliance with TPL-007-1 that necessitate data sharing, model building, process creation, and first-of-its-kind analysis are already significant. The analysis tools needed for completion of the Vulnerability Assessment required by TPL-007-1 are not available in the industry at this time. The NERC GMD Task Force identified Task 7 to develop tools for system-wide harmonic assessment; however, this task is not scheduled to be complete until the fourth quarter of 2019.
- The additional efforts necessary to comply with Requirements R8 – R10 within the same timeline will result in an unreasonable resource burden that does not provide commensurate reliability benefits.

Likes 0

Dislikes 0

## Response

Thank you for your comment. The SDT has proposed the phasing-in of version 2 into the timing of the implementation of version 1, depending on the timing of approval of the revised standard by FERC.

**Joshua Eason - Joshua Eason On Behalf of: Michael Puscas, ISO New England, Inc., 2; - Joshua Eason**

Answer

No

Document Name

## Comment

ISO-NE does not agree with the January 2021 transition date in the implementation plan. The concern is that the base case used for TPL-007-01 will be obsolete by January 2023 according to the requirement to use a case within the Near-Term Transmission Planning Horizon. Note that the timing for meeting R2 and R4 in TPL-007-1 and the desire to model an as known system as possible (e.g. minimizing the need for case changes as new projects will have been approved and retirements have been announced) has driven ISO-NE to select a study year of 2023. This will create issues when stakeholders review the results and may cause additional study and case building efforts during the first cycle for meeting the new TPL-007-1 reliability standard. ISO-NE proposes that the transition deadline date should be changed from January 2021 to January 2019 or July 2019 so that the base case used for testing with the benchmark waveform according to the known timing for TPL-007-1 can be used for testing the supplemental waveform.

Question 7

Likes 0

Dislikes 0

**Response**

Thank you for your comment. The SDT has revised the Implementation Plan based on comments received. See the revised Implementation Plan.

**Payam Farahbakhsh - Hydro One Networks, Inc. - 1**

**Answer** No

**Document Name**

**Comment**

Consistent with our comments above

Likes 1 Hydro One Networks, Inc., 3, Malozewski Paul

Dislikes 0

**Response**

**Donald Lock - Talen Generation, LLC - 5**

**Answer** No

**Document Name**

**Comment**

The four-year hardware implementation deadline in R7.3.2 may be impractical, especially if need for a large number of entities to install GIC blocking devices leads to extended lead-times for this equipment. The same issue was thoroughly investigated by the PRC-025 SDT (see the Implementation Plan for this standard), leading to an 84-months deadline, and we recommend that the TPL-007-2 SDT follow this precedent.

Likes 0

## Question 7

Dislikes 0

**Response**

Thank you for your comment. The SDT notes that the development of the CAP allows one year and four years for completing the hardware mitigation. The standard has included a process for reporting delays in implementation beyond the deadline due to factors outside of the entity's control (R7.4).

**Quintin Lee - Eversource Energy - 1**

Answer No

Document Name

**Comment**

The compliance date for Requirement R9 (if TPL-007-2 becomes effective before January 1, 2021) is too short. We would propose a compliance date of 12 months after the effective date of Reliability Standard TPL-007-2 if it becomes effective before January 1, 2021.

Likes 0

Dislikes 0

**Response**

Thank you for your comment. The SDT has revised the Implementation Plan based on comments received. See the revised Implementation Plan.

**Chris Scanlon - Exelon - 1**

Answer No

Document Name

**Comment**

## Question 7

The implementation plan is not clear on whether the Standard Drafting Team intends on replacing the effective dates of TPL-007-1 for all requirements with the effective date and compliance dates for TPL-007-2 or carrying forward the TPL-007-1 effective dates. Please provide additional language to outline the SDT's intent with the timing between TPL-007-1 effective dates and TPL-007-2 effective dates. Similarly, as the implementation plan is written, under certain situations, the effective dates for performing the assessments for the supplemental event may not necessarily align with the periodicity for performing the assessments for the benchmark event currently required under TPL-007-1, which may create an unnecessary burden for performing assessments on separate cycles.

Likes	0
-------	---

Dislikes	0
----------	---

## Response

Thank you for your comment. The intent of the TPL-007-2 implementation plan is to integrate the new requirements with the GMD assessment process that is being implemented through TPL-007-1. The implementation plan phases in the new requirements based on the effective dates of TPL-007-1 and the earliest possible date that the FERC approval dates of the new revised standard could occur.

**Marty Hostler - Northern California Power Agency - 5**

Answer	No
--------	----

Document Name	
---------------	--

## Comment

Current implementation dates for requirements 2-6 are January 1, 2021. The implementation plan for TOP-007-2 is confusing. In one bullet it says the effective date is on or before January 1, 2021, and the bullet below it says the effective date is after January 1, 2021.

Likes	0
-------	---

Dislikes	0
----------	---

## Response

Thank you for your comment. The SDT has revised the Implementation Plan based on comments received. See the revised Implementation Plan. Current implementation dates for requirements R2, R3, and R4 is January 2022 and R5 is January 2019 and R6 is January 2021. The intent of the TPL-007-2 implementation plan is to integrate the new requirements with the GMD assessment process that is being

## Question 7

implemented through TPL-007-1. The implementation plan phases in the new requirements based on the probable FERC approval dates of the new revised standard.

**Sergio Banuelos - Tri-State G and T Association, Inc. - 1,3,5 - MRO,WECC**

**Answer** No

**Document Name**

**Comment**

As currently written, the implementation plan can actually shorten the current timeframes to become compliant with TPL-007 requirements. It seems that if TPL-007-2 was approved and became effective 7/1/18, then R1, R2, and R5 would also be effective 7/1/18. However, TPL-007-1 R5 isn't supposed to go into effect until 7/1/19. The TPL-007-2 implementation plan should be revised so that entities have at least until the TPL-007-1 effective dates to comply with requirements R1-R7. Tri-State recommends adding language similar to the commonly used "shall become effective on the later of XXXX or the first day of the XX calendar quarter". That would prevent entities from losing time they might have already planned on having to become complaint with R2-R7.

Likes 0

Dislikes 0

**Response**

Thank you for your comment. The intent of the TPL-007-2 implementation plan is to integrate the new requirements with the GMD assessment process that is being implemented through TPL-007-1. The implementation plan phases in the new requirements based on the effective dates of TPL-007-1 and the earliest possible date that the FERC approval dates of the new revised standard could occur. If so, the effective dates to be compliant with Requirements R1 and R2 would be extended by six months and Requirement R5 would be the same as the effective date. Although possible, it is not likely.

**Dennis Sismaet - Northern California Power Agency - 6**

**Answer** No

**Document Name**

**Comment**



**Question 7**

Current implementation dates for requirements 2-6 are January 1, 2021. The implementation plan for TOP-007-2 is confusing. In one bullet, it says the effective date is on or before January 1, 2021, and the bullet below it says the effective date is after January 1, 2021.

Likes 0

Dislikes 0

**Response**

Thank you for your comment. The intent of the TPL-007-2 implementation plan is to integrate the new requirements with the GMD assessment process that is being implemented through TPL-007-1. The implementation plan phases in the new requirements based on the effective dates of TPL-007-1 and the earliest possible date that the FERC approval dates of the new revised standard could occur. The current compliance dates for TPL-007-1 are not as stated. Please refer to the NERC website for the enforcement dates.

**William Harris - Foundation for Resilient Societies - 8**

**Answer**

No

**Document Name**

**Comment**

We favor a combined standard for GMD and HEMP events, so that the U.S. electric grid is actually protected against severe solar storms and so it can aid in deterrence, protection and recovery from both natural and manmade electromagnetic pulse hazards.

Likes 0

Dislikes 0

**Response**

Thank you for your comment. Combining GMD with HEMP is outside the scope of this SDT.

**Thomas Foltz - AEP - 5**

**Answer**

Yes

**Document Name**

**Comment**

## Question 7

AEP would like clarity on the type of duration (e.g. Calendar Year or Calendar Month) being proposed. This is not explicit in the current draft of the implementation plan.

Likes 0

Dislikes 0

## Response

Thank you for your comment. The referenced months that do not use “calendar month” are simply a count of the months following approval.

**sean erickson - Western Area Power Administration - 1**

Answer Yes

Document Name

## Comment

[TPLTF](#)<sup>15</sup> Discussion: The group agrees with the proposed Implementation Plan for TPL-007-2 and does not see any conflicts with the order by which the phased requirements become effective. However, given the lack of available tools, absence of thermal modeling-related data from transformer manufacturers, and the significant training that will be necessary to properly execute transformer thermal assessments, the group believes that the implementation period for Requirement R10 should be at least 48 months after the standard is approved. This suggested implementation period is consistent with the existing implementation period for Requirement R6 (transformer thermal assessment for benchmark GMD event) and should allow sufficient time for many more transformers that may be observed to exceed the supplemental GMD event screening criterion.

Likes 0

Dislikes 0

## Response

Thank you for your comment.

<sup>15</sup> TPLTF document is found at the end of this document in Attachment 1.

Question 7

**Elizabeth Axson - Electric Reliability Council of Texas, Inc. - 2, Group Name** IRC Standards Review Committee

**Answer** Yes

**Document Name**

**Comment**

ISO-NE does not join this response.

Likes 0

Dislikes 0

**Response**

**Randy Buswell - VELCO -Vermont Electric Power Company, Inc. - 1**

**Answer** Yes

**Document Name**

**Comment**

Likes 0

Dislikes 0

**Response**

**Lauren Price - American Transmission Company, LLC - 1**

**Answer** Yes

**Document Name**

**Comment**

Question 7

Likes 0

Dislikes 0

Response

RoLynda Shumpert - SCANA - South Carolina Electric and Gas Co. - 1,3,5,6 - SERC

Answer Yes

Document Name

Comment

Likes 0

Dislikes 0

Response

Ann Ivanc - FirstEnergy - FirstEnergy Solutions - 6

Answer Yes

Document Name

Comment

Likes 0

Dislikes 0

Response

Question 7

**Aaron Cavanaugh - Bonneville Power Administration - 1,3,5,6 - WECC**

**Answer** Yes

**Document Name**

**Comment**

Likes 0

Dislikes 0

**Response**

**Daniel Grinkevich - Con Ed - Consolidated Edison Co. of New York - 1**

**Answer** Yes

**Document Name**

**Comment**

Likes 0

Dislikes 0

**Response**

**Michael Shaw - Lower Colorado River Authority - 6, Group Name LCRA Compliance**

**Answer** Yes

**Document Name**

Question 7

Comment

Likes 0

Dislikes 0

Response

Robert Blackney - Edison International - Southern California Edison Company - 1,3,5,6 - WECC

Answer Yes

Document Name

Comment

Likes 0

Dislikes 0

Response

Gerry Huitt - Xcel Energy, Inc. - 5

Answer Yes

Document Name

Comment

Likes 0

Dislikes 0

Question 7

Response

Neil Swearingen - Salt River Project - 1,3,5,6 - WECC

Answer Yes

Document Name

Comment

Likes 0

Dislikes 0

Response

Karie Barczak - DTE Energy - Detroit Edison Company - 3

Answer Yes

Document Name

Comment

Likes 0

Dislikes 0

Response

Eric Shaw - Eric Shaw On Behalf of: Lee Maurer, Oncor Electric Delivery, 1; - Eric Shaw

Answer Yes

Question 7

Document Name

Comment

Likes 0

Dislikes 0

Response

Jeffrey Watkins - Jeffrey Watkins On Behalf of: Eric Schwarzrock, Berkshire Hathaway - NV Energy, 5; - Jeffrey Watkins

Answer

Yes

Document Name

Comment

Likes 0

Dislikes 0

Response

Glen Farmer - Avista - Avista Corporation - 5

Answer

Yes

Document Name

Comment

Likes 0



Question 7

Dislikes 0

Response

**Douglas Webb - Douglas Webb On Behalf of: Chris Bridges, Great Plains Energy - Kansas City Power and Light Co., 3, 6, 5, 1; Harold Wyble, Great Plains Energy - Kansas City Power and Light Co., 3, 6, 5, 1; James McBee, Great Plains Energy - Kansas City Power and Light Co., 3, 6, 5, 1; Jessica Tucker, Great Plains Energy - Kansas City Power and Light Co., 3, 6, 5, 1; - Douglas Webb**

Answer Yes

Document Name

Comment

Likes 0

Dislikes 0

Response

**Stephanie Burns - Stephanie Burns On Behalf of: Michael Moltane, International Transmission Company Holdings Corporation, 1; - Stephanie Burns**

Answer Yes

Document Name

Comment

Likes 0

Dislikes 0

Question 7

Response

David Ramkalawan - Ontario Power Generation Inc. - 5

Answer Yes

Document Name

Comment

Likes 0

Dislikes 0

Response

Ruida Shu - Northeast Power Coordinating Council - 1,2,3,4,5,6,7,8,9,10 - NPCC, Group Name RSC no Hydro One, HQ and IESO

Answer Yes

Document Name

Comment

Likes 0

Dislikes 0

Response

Brian Van Gheem - ACES Power Marketing - 6 - NA - Not Applicable, Group Name ACES Standards Collaborators

Answer Yes

Question 7

Document Name

Comment

Likes 0

Dislikes 0

Response

James Anderson - CMS Energy - Consumers Energy Company - 1,3,4,5

Answer Yes

Document Name

Comment

Likes 0

Dislikes 0

Response

Shannon Mickens - Southwest Power Pool, Inc. (RTO) - 2 - SPP RE, Group Name SPP Standards Review Group

Answer Yes

Document Name

Comment

The SPP Standards Review Group agrees with the proposed Implementation Plan for TPL-007-2 and does not see any conflicts with the order by which the phased requirements become effective. However, given the lack of available tools, absence of thermal modeling-related data

## Question 7

from transformer manufacturers, and the significant training that will be necessary to properly execute transformer thermal assessments, the group believes that the implementation period for Requirement R10 should be at least 48 months after the standard is approved. This suggested implementation period is consistent with the existing implementation period for Requirement R6 (transformer thermal assessment for benchmark GMD event) and should allow sufficient time for many more transformers that may be observed to exceed the supplemental GMD event screening criterion.

Likes	0
-------	---

Dislikes	0
----------	---

**Response**

Thank you for your comment.

**Michael Buyce - City Utilities of Springfield, Missouri - 1**

Answer	Yes
--------	-----

Document Name	
---------------	--

Comment	
---------	--

Likes	0
-------	---

Dislikes	0
----------	---

**Response**

**Terry Harbour - Berkshire Hathaway Energy - MidAmerican Energy Co. - 1**

Answer	Yes
--------	-----

Document Name	
---------------	--

Comment	
---------	--

## Question 7

Likes 0

Dislikes 0

## Response

## Rachel Coyne - Texas Reliability Entity, Inc. - 10

## Answer

## Document Name

## Comment

Texas RE appreciates the SDT's efforts to develop a workable Implementation Plan (IP) for TPL-007-2 that reflects the modifications required by FERC's directives in Order No. 830 while attempting to maintain the original five-year phased implementation timeframe established for TPL-007-1. As presently drafted, however, the proposed TPL-007-1 IP attempts to coordinate the existing TPL-007-1 deadlines with the new TPL-007-2 requirements by shortening the compliance dates under the version 2 standard by 18 months in circumstances in which FERC approves the new version before January 1, 2021. This appears roughly coordinated with the May 2018 filing deadline established in Order No. 830.

While Texas RE does not object to this approach, Texas RE notes that the TPL-007-2 IP, as currently drafted, is complex and could produce several unintended consequences as entities interpret their layered compliance obligation timelines. In particular, the proposed IP requires entities to now potentially track two IPs. For instance, the TPL-007-2 IP is drafted such that the enforceable dates for TPL-007-1 R2, presently July 1, 2018, remain under the original IP. While this is a reasonable approach, the SDT should consider explicitly incorporating the deadlines from the TPL-007-1 IP into the TPL-007-2 IP, at least by reference. By taking this approach, the SDT can ensure that responsible entities clearly understand the relevant compliance dates for each Standard requirement and eliminate confusion regarding which compliance dates are subject to revision and which are not.

Such additional clarity may be particularly important in connection with the enforceable dates for TPL-007-2 R5. Under the TPL-007-1 IP, TPL-007-1 R5 is enforceable on January 1, 2019. The proposed TPL-007-2 IP does not address the enforceable date for TPL-007-2 R5. As such, entities are presumably required to comply with TPL-007-2 R5 on the effective date of the Standard. Texas RE presumes that the SDT anticipates that TPL-007-2 will not be effective and enforceable prior to January 1, 2019 given the May 2018 filing deadline, the period for FERC approval, the 60-day period for the FERC order to become final, and the fact that the Standard does not become effective until the first

Question 7

day of the calendar quarter three months after the FERC order is final. However, given the status of this project, it is possible that NERC may wish to submit a revised TPL-007-2 prior to May 2018. For instance, suppose NERC submits a proposal in January 2018 and FERC issues its order in April 2018. The FERC order would become final by July 1, 2018. As such, TPL-007-2 would become enforceable on October 1, 2018. As a result, entities' compliance deadlines would be inadvertently accelerated from January 1, 2019 to October 1, 2018. The SDT should avoid this possibility by clearly delineating within the TPL-007-2 IP which TPL-007-1 enforceable dates remain applicable. Conversely, the proposed TPL-007-2 IP can be interpreted to extend the compliance deadline for the Benchmark GMD study required under TPL-007 R4 by five years. In particular, the TPL-007-2 IP does not specify an Initial Performance date for the 60-month periodic requirement set forth in TPL-007-2 R4. As such, a plausible reading of the IP is that TPL-007-2 R4 does not become enforceable for 42 months and then, when enforceable, entities have an additional 60 months to complete the Benchmark GMD study under TPL-007-2 R4's periodic performance requirement. This is consistent with NERC's IP guidance in Compliance Application Notice (CAN) No. 12, which states: "[I]n the event the Standard or interpretation is silent with regard to completing a periodic activity, CEAs are to verify that the registered entity has performed the periodic activity within the Standard's timeframe after the enforceable date." (CAN 12 at 1-2). Here, TPL-007-2 R4's enforceable date is set at 42 months from the effective date of the overall Standard. No initial performance date is specified. As such, a responsible entity may reasonably conclude that it has the full 60 month window specified in TPL-007-2 R4 to complete the Benchmark GMD Vulnerability Assessment. This result appears to run counter to the SDT's intent. Texas RE therefore recommends the SDT clearly specify that the initial performance of the TPL-007-2 R4 Benchmark GMD Vulnerability Assessment is due on the enforceable date of that requirement or 42 months from the TPL-007-2 effective date. The same logic can be applied to Requirement R8 as well.

Likes 0

Dislikes 0

Response

Thank you for your comment. The SDT has revised the Implementation Plan based on comments received. See the revised Implementation Plan.

**Brandon McCormick - Brandon McCormick On Behalf of: Carol Chinn, Florida Municipal Power Agency, 5, 6, 4, 3; David Schumann, Florida Municipal Power Agency, 5, 6, 4, 3; Ginny Beigel, City of Vero Beach, 3; Jeffrey Partington, Keys Energy Services, 4; Joe McKinney, Florida Municipal Power Agency, 5, 6, 4, 3; Mike Blough, Kissimmee Utility Authority, 5, 3; Richard Montgomery, Florida Municipal Power Agency, 5, 6, 4, 3; Tom Reedy, Florida Municipal Power Pool, 6; - Brandon McCormick, Group Name FMPA**

Answer

## Question 7

## Document Name

## Comment

We would ask that the implementation plan for TPL-007-2 be clearer than it is, especially since the implementation plan for TPL-007-1 is currently underway. We appreciate the efforts of the drafting team in developing the implementation plan for TPL-007-2. However, while it may make perfect sense to the drafting team, it is not clear enough to be used for a compliance standard. Please consider providing some examples, a timeline chart, or providing an acknowledgement of the current dates that entities will be working towards. For example, the selection of the January 2021 date as the “dividing line” between “concurrent implementation” and apparently “non-current” implementation, of the Supplemental and Benchmark events seems to imply the SDT believes one year is sufficient time to add the supplemental event to the benchmark Vulnerability Assessments that are already underway and required to be complete for TPL-007-1 by January of 2022. However, the “more specific” dates offered for Requirements R3, R4 and R8 are 42 months out, which is not January of 2022...so what exactly is intended by “concurrent” and what benefit is gained?

Likes 0

Dislikes 0

## Response

Thank you for your comment. The SDT has revised the Implementation Plan based on comments received. See the revised Implementation Plan.

**Thomas Rafferty - Edison International - Southern California Edison Company - 5**

## Answer

## Document Name

## Comment

Please refer to comments submitted by Robert Blackney on behalf of Southern California Edison

Likes 0

Dislikes 0

## Response

## Question 7

No comments were submitted.

**Richard Vine - California ISO - 2**

**Answer**

**Document Name**

**Comment**

The California ISO supports the joint comments of the ISO/RTO Standards Review Committee

Likes 0

Dislikes 0

**Response**

Thank you for supporting the comments of the IRC Standards Review Committee (i.e., ISO/RTO Standards Review Committee).



**Question 8**

**8. Do you agree with the Violation Risk Factors (VRFs) and Violation Severity Levels (VSLs) for the requirements in proposed TPL-007-2? If you do not agree, or if you agree but have comments or suggestions for the VRFs and VSLs provide your recommendation and explanation.**

**Dennis Sismaet - Northern California Power Agency - 6**

**Answer** No

**Document Name**

**Comment**

They should be low or medium violation severity levels and risk factors at the most.

Likes 0

Dislikes 0

**Response**

Thank you for your comment. All VSLs<sup>16</sup> and VRFs<sup>17</sup> are consistent with NERC guidelines.

**Marty Hostler - Northern California Power Agency - 5**

**Answer** No

**Document Name**

**Comment**

They should be low or medium violaton severity levels and risk factors at the most.

Likes 0

Dislikes 0

**Response**

<sup>16</sup> [http://www.nerc.com/pa/Stand/Resources/Documents/VSL\\_Guidelines.PDF](http://www.nerc.com/pa/Stand/Resources/Documents/VSL_Guidelines.PDF)

<sup>17</sup> [http://www.nerc.com/pa/Stand/Resources/Documents/Violation\\_Risk\\_Factors.pdf](http://www.nerc.com/pa/Stand/Resources/Documents/Violation_Risk_Factors.pdf)

Question 8

Thank you for your comment. All VSLs<sup>18</sup> and VRFs<sup>19</sup> are consistent with NERC guidelines.

**Brian Van Gheem - ACES Power Marketing - 6 - NA - Not Applicable, Group Name** ACES Standards Collaborators

**Answer** No

**Document Name**

**Comment**

Since the standard clearly identifies separate GMD Vulnerability Assessments for benchmark and supplemental GMD events, we believe an entity could define separate acceptable System steady state voltage performance criteria for each study. Hence, the Violation Severity Limit for Requirement R3 should be expanded with stair-step severity limits that account for an entity having one criteria for one type of event and not the other.

Likes 0

Dislikes 0

**Response**

Thank you for your comment. The VSL is binary because to address criteria as a single item.

**Payam Farahbakhsh - Hydro One Networks, Inc. - 1**

**Answer** No

**Document Name**

**Comment**

Consistent with our comments above

Likes 1 Hydro One Networks, Inc., 3, Malozewski Paul

Dislikes 0

<sup>18</sup> [http://www.nerc.com/pa/Stand/Resources/Documents/VSL\\_Guidelines.PDF](http://www.nerc.com/pa/Stand/Resources/Documents/VSL_Guidelines.PDF)

<sup>19</sup> [http://www.nerc.com/pa/Stand/Resources/Documents/Violation\\_Risk\\_Factors.pdf](http://www.nerc.com/pa/Stand/Resources/Documents/Violation_Risk_Factors.pdf)

## Question 8

## Response

Thank you for your comment. The SDT did not find Hydro One comments above pertaining to VRF or VSL.

**Colby Bellville - Colby Bellville On Behalf of: Dale Goodwine, Duke Energy , 6, 5, 3, 1; - Colby Bellville, Group Name Duke Energy**

**Answer** No

**Document Name**

## Comment

Duke Energy recommends that the drafting team revisit the order used for the Lower VSL for R8. The first statement in the Lower VSL section regarding the responsible entity completing a supplemental GMD Vulnerability Assessment in more than 60 calendar months, should actually swap positions with the second clause regarding the entity failing to satisfy one of the elements in R8. Having these two clauses swap places, would align with the order of language used in the Moderate, High, and Severe VSL(s).

Likes 0

Dislikes 0

## Response

Thank you for your comment The SDT has swapped the clauses in the Lower VSL to make it consistent with the Moderate, High, and Serve VSL for Requirement R8.

**Michelle Amarantos - APS - Arizona Public Service Co. - 1**

**Answer** No

**Document Name**

## Comment

As discussed above, AZPS has identified inconsistency in the treatment of a failure of registered entities to meet the deadline set forth for certain administrative requirements. In some instances, the VSL is simply a binary element and does not increase based on duration of delay or other factors. In other instances, the VSL increases as the duration of the delay increases. Such inconsistency alone is problematic, but, when the administrative nature of and horizon within which these requirements occur are considered, it becomes clear that the VSLs are out of sync with the actual or potential impact that would result from an entity's failure to comply. As these are administrative requirements

## Question 8

(provision of documents and/or responses) occurring in the planning horizon, AZPS respectfully asserts that all such VSLs should be considered “low” and should not increase beyond that level, which is similar to the treatment in Requirement R8. AZPS recommends that the SDT review not only the new requirements, but the existing requirements to ensure that the VSLs accurately reflect their administrative nature and the fact that the horizon within which these activities are occurring is the Planning Horizon. Specific requirements that should be reviewed for consistency regarding the applicable VSLs include all requirement/sub-requirements with a 90 day timeframe for compliance, e.g., Requirements R4.3, R4.3.1, R5, R7.5, R7.5.1, R8.4, R8.4.1, and R9.2. Again, AZPS respectfully recommends that the SDT treat all 90-day time frame administrative requirements as binary requirements with a low VSL.

Likes 0

Dislikes 0

## Response

Thank you for your comment. The gradation of the VSLs for Requirements with a timing component is consistent with the [guideline for developing VSLs](#).<sup>20</sup> Regardless of whether a Requirement is administrative or not, a binary Requirement (i.e., met or not met) can only have a single Severe category. Not performing the Requirement is the most severe violation of the Requirement.

**Mike Smith - Manitoba Hydro - 1, Group Name** Manitoba Hydro

Answer

No

Document Name

## Comment

There should be trial period for industry to gain understanding and knowledge of GMD before implementing a standard.

Likes 0

Dislikes 0

## Response

Thank you for your comment.

<sup>20</sup> [http://www.nerc.com/pa/Stand/Resources/Documents/VSL\\_Guidelines.PDF](http://www.nerc.com/pa/Stand/Resources/Documents/VSL_Guidelines.PDF)

Question 8

**Thomas Foltz - AEP - 5**

**Answer** No

**Document Name**

**Comment**

The VSL for R2 is based on the maintenance of a System Model that is already required by other reliability standards (MOD-032). It is unclear why this is a basis for the VSL for this requirement. The VSL for requirement R2 should pertain to the unique information required by the GIC vulnerability assessments contained in this standard. AEP recommends having only one Severe VSL for not maintaining GIC model data.

Likes 0

Dislikes 0

**Response**

Thank you for your comment. The maintenance of models in MOD-032 is different from the models used for GMD assessments. The SDT proposed a High and Severe VSL to account for partial failure where only one model was maintained, but not both.

**Shannon Mickens - Southwest Power Pool, Inc. (RTO) - 2 - SPP RE, Group Name SPP Standards Review Group**

**Answer** Yes

**Document Name**

**Comment**

Likes 0

Dislikes 0

**Response**

**Nicolas Turcotte - Hydro-Québec TransEnergie - 1**

## Question 8

<b>Answer</b>	Yes
---------------	-----

<b>Document Name</b>	
----------------------	--

**Comment**

We suggest adding the following High VSL.

"The Planning Coordinator, in conjunction with its Transmission Planner(s), failed to determine and identify individual or joint responsibilities of the Planning Coordinator and Transmission Planner(s) in the Planning Coordinator's planning area for maintaining models and, performing the study or studies needed to complete benchmark and supplemental GMD Vulnerability Assessment(s).,

Or

implementing process(es) to obtain GMD measurement data as specified in this standard."

Likes	0
-------	---

Dislikes	0
----------	---

**Response**

Thank you for your comment. The above suggestion does not provide additional clarity. The performance of Requirement R1 is to "identify the individual and joint responsibilities" and the additional information outlines what individual and joint responsibilities are being identified by the applicable entities.

**Chantal Mazza - Hydro-Québec TransEnergie - 1,2 - NPCC**

<b>Answer</b>	Yes
---------------	-----

<b>Document Name</b>	
----------------------	--

**Comment**

We suggest adding the following High VSL.

"The Planning Coordinator, in conjunction with its Transmission Planner(s), failed to determine and identify individual or joint responsibilities of the Planning Coordinator and Transmission Planner(s) in the Planning Coordinator's planning area for maintaining models and, performing the study or studies needed to complete benchmark and supplemental GMD Vulnerability Assessment(s),

Or

implementing process(es) to obtain GMD measurement data as specified in this standard."

Question 8

Likes 0

Dislikes 0

**Response**

Thank you for your comment. The above suggestion does not provide additional clarity. The performance of Requirement R1 is to “identify the individual and joint responsibilities” and the additional information outlines what individual and joint responsibilities are being identified by the applicable entities.

**Michael Shaw - Lower Colorado River Authority - 6, Group Name LCRA Compliance**

**Answer** Yes

**Document Name**

**Comment**

The VRFs should be included in the VSL table within the standard. It isn’t clear why they were struck.

Likes 0

Dislikes 0

**Response**

Thank you for your comment. The Time Horizons and VRF items were removed from the Results-based Standard (RBS) template to increase the space for writing VSL language and to eliminate the potential for errors to be introduced when they do not match the Requirement(s).

**Terry Harbour - Berkshire Hathaway Energy - MidAmerican Energy Co. - 1**

**Answer** Yes

**Document Name**

**Comment**

Likes 0

Question 8

Dislikes 0

Response

Sergio Banuelos - Tri-State G and T Association, Inc. - 1,3,5 - MRO,WECC

Answer Yes

Document Name

Comment

Likes 0

Dislikes 0

Response

Elizabeth Axson - Electric Reliability Council of Texas, Inc. - 2, Group Name IRC Standards Review Committee

Answer Yes

Document Name

Comment

Likes 0

Dislikes 0

Response

Chris Scanlon - Exelon - 1



Question 8

Answer Yes

Document Name

Comment

Likes 0

Dislikes 0

Response

Michael Buyce - City Utilities of Springfield, Missouri - 1

Answer Yes

Document Name

Comment

Likes 0

Dislikes 0

Response

James Anderson - CMS Energy - Consumers Energy Company - 1,3,4,5

Answer Yes

Document Name

Comment

Question 8

Likes 0

Dislikes 0

Response

Ruida Shu - Northeast Power Coordinating Council - 1,2,3,4,5,6,7,8,9,10 - NPCC, Group Name RSC no Hydro One, HQ and IESO

Answer Yes

Document Name

Comment

Likes 0

Dislikes 0

Response

David Ramkalawan - Ontario Power Generation Inc. - 5

Answer Yes

Document Name

Comment

Likes 0

Dislikes 0

Response

Question 8

**Quintin Lee - Eversource Energy - 1**

**Answer** Yes

**Document Name**

**Comment**

Likes 0

Dislikes 0

**Response**

**Stephanie Burns - Stephanie Burns On Behalf of: Michael Moltane, International Transmission Company Holdings Corporation, 1; - Stephanie Burns**

**Answer** Yes

**Document Name**

**Comment**

Likes 0

Dislikes 0

**Response**

**Douglas Webb - Douglas Webb On Behalf of: Chris Bridges, Great Plains Energy - Kansas City Power and Light Co., 3, 6, 5, 1; Harold Wyble, Great Plains Energy - Kansas City Power and Light Co., 3, 6, 5, 1; James McBee, Great Plains Energy - Kansas City Power and Light Co., 3, 6, 5, 1; Jessica Tucker, Great Plains Energy - Kansas City Power and Light Co., 3, 6, 5, 1; - Douglas Webb**

Question 8

Answer Yes

Document Name

Comment

Likes 0

Dislikes 0

Response

Donald Lock - Talen Generation, LLC - 5

Answer Yes

Document Name

Comment

Likes 0

Dislikes 0

Response

Glen Farmer - Avista - Avista Corporation - 5

Answer Yes

Document Name

Comment

Question 8

Likes 0

Dislikes 0

Response

Jeffrey Watkins - Jeffrey Watkins On Behalf of: Eric Schwarzrock, Berkshire Hathaway - NV Energy, 5; - Jeffrey Watkins

Answer Yes

Document Name

Comment

Likes 0

Dislikes 0

Response

Eric Shaw - Eric Shaw On Behalf of: Lee Maurer, Oncor Electric Delivery, 1; - Eric Shaw

Answer Yes

Document Name

Comment

Likes 0

Dislikes 0

Response

Question 8

Joshua Eason - Joshua Eason On Behalf of: Michael Puscas, ISO New England, Inc., 2; - Joshua Eason

Answer Yes

Document Name

Comment

Likes 0

Dislikes 0

Response

Rachel Coyne - Texas Reliability Entity, Inc. - 10

Answer Yes

Document Name

Comment

Likes 0

Dislikes 0

Response

Laurie Williams - PNM Resources - Public Service Company of New Mexico - 1

Answer Yes

Document Name

Comment

Question 8

Likes 0

Dislikes 0

Response

**Karie Barczak - DTE Energy - Detroit Edison Company - 3**

Answer Yes

Document Name

Comment

Likes 0

Dislikes 0

Response

**Neil Swearingen - Salt River Project - 1,3,5,6 - WECC**

Answer Yes

Document Name

Comment

Likes 0

Dislikes 0

Response

Question 8

Dana Klem - MRO - 1,2,3,4,5,6 - MRO, Group Name MRO NSRF

Answer Yes

Document Name

Comment

Likes 0

Dislikes 0

Response

Laura Nelson - IDACORP - Idaho Power Company - 1

Answer Yes

Document Name

Comment

Likes 0

Dislikes 0

Response

Gerry Huitt - Xcel Energy, Inc. - 5

Answer Yes

Document Name



Question 8

Comment

Likes 0

Dislikes 0

Response

Robert Blackney - Edison International - Southern California Edison Company - 1,3,5,6 - WECC

Answer Yes

Document Name

Comment

Likes 0

Dislikes 0

Response

sean erickson - Western Area Power Administration - 1

Answer Yes

Document Name

Comment

Likes 0

Dislikes 0

Question 8

Response

Daniel Grinkevich - Con Ed - Consolidated Edison Co. of New York - 1

Answer Yes

Document Name

Comment

Likes 0

Dislikes 0

Response

Aaron Cavanaugh - Bonneville Power Administration - 1,3,5,6 - WECC

Answer Yes

Document Name

Comment

Likes 0

Dislikes 0

Response

Ann Ivanc - FirstEnergy - FirstEnergy Solutions - 6

Answer Yes

Question 8

Document Name

Comment

Likes 0

Dislikes 0

Response

RoLynda Shumpert - SCANA - South Carolina Electric and Gas Co. - 1,3,5,6 - SERC

Answer

Yes

Document Name

Comment

Likes 0

Dislikes 0

Response

Randy Buswell - VELCO -Vermont Electric Power Company, Inc. - 1

Answer

Yes

Document Name

Comment

Likes 0

## Question 8

Dislikes 0

**Response****Richard Vine - California ISO - 2****Answer****Document Name****Comment**

The California ISO supports the joint comments of the ISO/RTO Standards Review Committee

Likes 0

Dislikes 0

**Response**

Thank you for supporting the comments of the IRC Standards Review Committee (i.e., ISO/RTO Standards Review Committee).

**Thomas Rafferty - Edison International - Southern California Edison Company - 5****Answer****Document Name****Comment**

Please refer to comments submitted by Robert Blackney on behalf of Southern California Edison

Likes 0

Dislikes 0

**Response**

No comments were submitted.

## Question 9

9. The SDT believes proposed TPL-007-2 provide entities with flexibility to meet the reliability objectives in the project Standards Authorization Request (SAR) in a cost effective manner. Do you agree? If you do not agree, or if you agree but have suggestions for improvement to enable additional cost effective approaches to meet the reliability objectives, please provide your recommendation and, if appropriate, technical justification.

Thomas Foltz - AEP - 5

Answer No

Document Name

#### Comment

While AEP agrees with the scope and direction of the revised standard, the incremental costs and resources required to comply with the proposed revisions may not be commensurate with the resulting impact to the improved reliability of the BES. Adding the Supplemental GMD Vulnerability obligations may substantially increase the resources involved, without a corresponding increase in the reliability of the BES.

Likes 0

Dislikes 0

#### Response

Thank you for your comment. The supplemental assessment is additional work, but it is necessary to account for the impacts of local enhancements. No additional system data is required.

Michael Shaw - Lower Colorado River Authority - 6, Group Name LCRA Compliance

Answer No

Document Name

#### Comment

This revision calls for even more assessment of an already rare condition that has historically not been very impactful at lower latitudes. I question the cost-benefit of this standard relative to other grid reliability needs.

Likes 0

Question 9

Dislikes 0

**Response**

Thank you for your comment. The SDT cannot comment on the priority of compliance with TPL-007-2 with respect to other needs that require attention on the system.

**Mike Smith - Manitoba Hydro - 1, Group Name** Manitoba Hydro

**Answer**

No

**Document Name**

**Comment**

There should be trial period for industry to gain understanding and knowledge of GMD before implementing a standard. Until initial assessments are completed, there's no idea of what a corrective action plan might look like, for example.

Likes 0

Dislikes 0

**Response**

Thank you for your comment. The SDT is being responsive to the Standards Authorization Request. The existing standard already has a vulnerability assessment requirement that is approved and effective and subject to compliance by applicable registered entities. The comment is suggesting an alternative methodology to the existing standard which is outside the scope of the SDT and should be addressed in a new SAR.

**Chantal Mazza - Hydro-Québec TransEnergie - 1,2 - NPCC**

**Answer**

No

**Document Name**

**Comment**

For the Hydro-Quebec power grid it would be already covered by the benchmark event.

Likes 0

## Question 9

Dislikes 0

**Response**

Thank you for your comment. The SDT is being responsive to the Standards Authorization Request.

**Nicolas Turcotte - Hydro-Québec TransEnergie - 1**

Answer No

Document Name

**Comment**

For the Hydro-Quebec power grid it would be already covered by the benchmark event.

Likes 0

Dislikes 0

**Response**

Thank you for your comment. The SDT is being responsive to the Standards Authorization Request.

**Karie Barczak - DTE Energy - Detroit Edison Company - 3**

Answer No

Document Name

**Comment**

Cost effectiveness can't be fully evaluated until more details are provided concerning how mitigation measures and GIC monitoring will be handled. Any required hardware mitigation and GIC monitoring could potentially be costly.

Likes 0

Dislikes 0

**Response**

Question 9

Thank you for your comment. The SDT agrees that the cost cannot be evaluated until we have gone through a cycle of the implementation plan.

**Laurie Williams - PNM Resources - Public Service Company of New Mexico - 1**

<b>Answer</b>	No
<b>Document Name</b>	
<b>Comment</b>	
Requirement R12 placed responsible entities an additional cost responsibility to collect magnetometer data which would be used just for model validation purpose. Collection of magnetometer data from government agencies or other appropriate agencies directly by NERC would avoid responsible entities' additional cost burden.	
Likes	0
Dislikes	0

**Response**

Thank you for your comment. The standard allows for obtaining a data product from sources like the USGS or NRCAn.

**Larisa Loyfer** The technical basis is not clear **man - CenterPoint Energy Houston Electric, LLC - 1 - Texas RE**

<b>Answer</b>	No
<b>Document Name</b>	
<b>Comment</b>	
CenterPoint Energy disagrees that the proposed TPL-007-2 provides entities with flexibility to meet the reliability objectives in the project Standards Authorization Request (SAR) in a cost effective manner. CenterPoint Energy's disagreement is based on the following:	
<ul style="list-style-type: none"> <li>• The proposed Implementation Plan for TPL-007-2 lacks the flexibility to complete the first-of-its-kind modeling and analysis before adding on additional enhanced analysis required to comply with Requirements R8 – R10.</li> <li>• The prescriptive implementation timelines required by revisions to Requirement R7 do not provide sufficient flexibility for entities to weigh competing system reliability goals in a cost effective manner.</li> </ul>	



**Question 9**

- Adding the Supplemental GMD Vulnerability obligations may substantially increase the resources involved, without a corresponding increase in the reliability of the BES.

Likes 0

Dislikes 0

**Response**

Thank you for your comment. The SDT has proposed the phasing-in of version 2 into the timing of the implementation of version 1, depending on the timing of approval of the revised standard by FERC.

The supplemental assessment is additional work, but it is necessary to account for the impacts of local enhancements.

**Payam Farahbakhsh - Hydro One Networks, Inc. - 1**

**Answer** No

**Document Name**

**Comment**

Consistent with our comments above

Likes 1 Hydro One Networks, Inc., 3, Malozewski Paul

Dislikes 0

**Response**

**Donald Lock - Talen Generation, LLC - 5**

**Answer** No

**Document Name**

**Comment**

## Question 9

TPL-007-2 continues the error of TPL-007-1 in allowing GOs to only suggest corrective actions (in R6.3), and giving the responsible entity in R7 sole authority to make establish CAPs without having to consult with GOs on the options available or (for competitive markets) demonstrate that all competitors are treated equally. This could be a significant issue, in that CAPs may include directives for, “Installation, modification, retirement or removal,” of multi-million-dollar equipment.

Likes	0
-------	---

Dislikes	0
----------	---

## Response

Thank you for your comment. The SDT expects that the development of the CAP would be a joint effort among the applicable entities. Requirement 7.5.1 provides a feedback loop for those functional entities who are referenced in the CAP.

**David Ramkalawan - Ontario Power Generation Inc. - 5**

Answer	No
--------	----

Document Name	
---------------	--

## Comment

OPG is of the opinion that the SDT can improve the cost effectiveness of the standard by combining the Benchmark and the Supplemental GMD events under one definition, thus eliminating duplicate/unnecessary work.

Likes	0
-------	---

Dislikes	0
----------	---

## Response

Thank you for your comment. The Transformer Thermal Impact Assessment White Paper and Screening Criterion for Transformer Thermal Impact Assessment documents have provided the technical foundation and methodologies that can be used to conduct transformer temperature rise calculations for both the benchmark case and the supplemental case.

**Chris Scanlon - Exelon - 1**

Answer	No
--------	----

## Question 9

## Document Name

## Comment

It is not clear whether the newly established supplemental event will have the effect of increasing the scope of transformers that meet the screening criteria, when compared to the benchmark event and if so, by how much. It does seem possible that an entity which has had no transformers identified as meeting the benchmark event screening criteria could have multiple or all transformers included within the scope of the supplemental event if it is located within the area of a localized enhancement. The technical justification for the supplemental event screening criteria does not substantiate what appears to be a disproportional increase in the intensity of the event compared to the increase in the screening threshold from 75A to 85A. Note that the approach to the thermal assessments required under R6 and R10 are the same, and therefore the proposed supplemental event screening criteria has the ability to impact the financial obligation of the TO and GO.

Likes 0

Dislikes 0

## Response

Thank you for your comment. Different screening thresholds were selected because benchmark and supplemental benchmark waveforms are different and their effects on transformers are different. The temperature thresholds are consistent, i.e., the thermal effects on a transformer are characterized by peak temperatures.

## Marty Hostler - Northern California Power Agency - 5

## Answer

No

## Document Name

## Comment

Increased costs do not justify the low, if any, reliability benefits.

Likes 0

Dislikes 0

## Response

**Question 9**

Thank you for your comment. In the development of the TPL-007-2: Transmission System Planned Performance for Geomagnetic Disturbance Events standard with supplemental GMD event, the SDT is being responsive to the Standards Authorization Request. The consensus of the SDT is that the supplemental GMD Vulnerability Assessment provides a reliability benefit.

**Dennis Sismaet - Northern California Power Agency - 6**

<b>Answer</b>	No
<b>Document Name</b>	
<b>Comment</b>	
Increased costs do not justify the low, if any, reliability benefits.	
Likes 0	
Dislikes 0	

**Response**

Thank you for your comment. In the development of the TPL-007-2: Transmission System Planned Performance for Geomagnetic Disturbance Events standard with supplemental GMD event, the SDT is being responsive to the Standards Authorization Request. The consensus of the SDT is that the supplemental GMD Vulnerability Assessment provides a reliability benefit.

**William Harris - Foundation for Resilient Societies - 8**

<b>Answer</b>	No
<b>Document Name</b>	Foundation for Resilient Societies on NERC Project 2013 081117_Submitted.docx
<b>Comment</b>	
The only cost-effective approach for grid protecton is to design for severe GMD hazards and manmade EMP hazards concurrently. This is not a cost effective method, and results in a needlessly vulnerable electric grid. See general comments.	
Likes 0	
Dislikes 0	

**Response**

## Question 9

Thank you for your comment. Protection of the BES for EMP hazards is outside the scope of the SDT.

**sean erickson - Western Area Power Administration - 1**

**Answer** Yes

**Document Name**

**Comment**

[TPLTF](#)<sup>21</sup> Discussion: The group agrees that the SDT has done a good job of considering cost in time, resources, and personnel commitment in meeting the objectives of the SAR, which were heavily prescribed by FERC Order No. 830. The group may not agree with the perceived benefit to reliability that the additional effort to analyze the supplemental GMD event will yield, but the SDT has proposed a solid means of addressing the FERC directives without relying on tools or methods that do not exist widely in industry today. The group also supports the SDT cost-effective approach to the proposed Requirement R7 which does not mention GIC blocking devices as an integral part of a hardware mitigation. The group remains concerned with the perception that GIC mitigation hardware is presently a viable solution. Given its cost, effects on Protection System design, as well as potential compromises to existing BES reliability, GIC blocking devices may prove undesirable. The flexibility that the SDT has proposed in the development of Corrective Action Plans is workable.

Likes 0

Dislikes 0

**Response**

The SDT appreciates the supportive comment.

**Stephanie Burns - Stephanie Burns On Behalf of: Michael Moltane, International Transmission Company Holdings Corporation, 1; - Stephanie Burns**

**Answer** Yes

**Document Name**

**Comment**

<sup>21</sup> TPLTF document is found at the end of this document in Attachment 1.

## Question 9

Considering the additional supplemental GMD event analysis doesn't require a CAP to be developed and that data collection is allowed as opposed to having to install new monitoring equipment on the system to acquire the required data, the proposed revisions are flexible and potentially more cost effective for some entities.

Likes 0

Dislikes 0

## Response

The SDT appreciates the supportive comment.

**Shannon Mickens - Southwest Power Pool, Inc. (RTO) - 2 - SPP RE, Group Name** SPP Standards Review Group

Answer

Yes

Document Name

## Comment

The SPP Standards Review Group agrees that the SDT has done a good job of considering cost in time, resources, and personnel commitment in meeting the objectives of the SAR, which were heavily prescribed by FERC Order No. 830. The group may not agree with the perceived benefit to reliability that the additional effort to analyze the supplemental GMD event will yield, but the SDT has proposed a solid means of addressing the FERC directives without relying on tools or methods that do not exist widely in industry today. We also support the SDT cost-effective approach to the proposed Requirement R7 which does not mention GIC blocking devices as an integral part of a hardware mitigation. The group remains concerned with the perception that GIC mitigation hardware is presently a viable solution. Given its cost, effects on Protection System design, as well as potential compromises to existing BES reliability, GIC blocking devices may prove undesirable. The flexibility that the SDT has proposed in the development of Corrective Action Plans is workable.

Likes 0

Dislikes 0

## Response

The SDT appreciates the supportive comment.

**Randy Buswell - VELCO -Vermont Electric Power Company, Inc. - 1**

Question 9

<b>Answer</b>	Yes
<b>Document Name</b>	
<b>Comment</b>	
Likes 0	
Dislikes 0	
<b>Response</b>	
<b>Lauren Price - American Transmission Company, LLC - 1</b>	
<b>Answer</b>	Yes
<b>Document Name</b>	
<b>Comment</b>	
Likes 0	
Dislikes 0	
<b>Response</b>	
<b>RoLynda Shumpert - SCANA - South Carolina Electric and Gas Co. - 1,3,5,6 - SERC</b>	
<b>Answer</b>	Yes
<b>Document Name</b>	
<b>Comment</b>	

Question 9

Likes 0

Dislikes 0

Response

Ann Ivanc - FirstEnergy - FirstEnergy Solutions - 6

Answer Yes

Document Name

Comment

Likes 0

Dislikes 0

Response

Daniel Grinkevich - Con Ed - Consolidated Edison Co. of New York - 1

Answer Yes

Document Name

Comment

Likes 0

Dislikes 0

Response



Question 9

**Robert Blackney - Edison International - Southern California Edison Company - 1,3,5,6 - WECC**

**Answer** Yes

**Document Name**

**Comment**

Likes 0

Dislikes 0

**Response**

**Gerry Huitt - Xcel Energy, Inc. - 5**

**Answer** Yes

**Document Name**

**Comment**

Likes 0

Dislikes 0

**Response**

**Laura Nelson - IDACORP - Idaho Power Company - 1**

**Answer** Yes

**Document Name**

**Comment**

Question 9

Likes 0

Dislikes 0

Response

Dana Klem - MRO - 1,2,3,4,5,6 - MRO, Group Name MRO NSRF

Answer Yes

Document Name

Comment

Likes 0

Dislikes 0

Response

Neil Swearingen - Salt River Project - 1,3,5,6 - WECC

Answer Yes

Document Name

Comment

Likes 0

Dislikes 0

Response

Question 9

**Eric Shaw - Eric Shaw On Behalf of: Lee Maurer, Oncor Electric Delivery, 1; - Eric Shaw**

**Answer** Yes

**Document Name**

**Comment**

Likes 0

Dislikes 0

**Response**

**Jeffrey Watkins - Jeffrey Watkins On Behalf of: Eric Schwarzrock, Berkshire Hathaway - NV Energy, 5; - Jeffrey Watkins**

**Answer** Yes

**Document Name**

**Comment**

Likes 0

Dislikes 0

**Response**

**Glen Farmer - Avista - Avista Corporation - 5**

**Answer** Yes

**Document Name**

Question 9

Comment

Likes 0

Dislikes 0

Response

Douglas Webb - Douglas Webb On Behalf of: Chris Bridges, Great Plains Energy - Kansas City Power and Light Co., 3, 6, 5, 1; Harold Wyble, Great Plains Energy - Kansas City Power and Light Co., 3, 6, 5, 1; James McBee, Great Plains Energy - Kansas City Power and Light Co., 3, 6, 5, 1; Jessica Tucker, Great Plains Energy - Kansas City Power and Light Co., 3, 6, 5, 1; - Douglas Webb

Answer

Yes

Document Name

Comment

Likes 0

Dislikes 0

Response

Quintin Lee - Eversource Energy - 1

Answer

Yes

Document Name

Comment

Question 9	
Likes 0	
Dislikes 0	
<b>Response</b>	
Ruida Shu - Northeast Power Coordinating Council - 1,2,3,4,5,6,7,8,9,10 - NPCC, Group Name RSC no Hydro One, HQ and IESO	
Answer	Yes
Document Name	
<b>Comment</b>	
Likes 0	
Dislikes 0	
<b>Response</b>	
Brian Van Gheem - ACES Power Marketing - 6 - NA - Not Applicable, Group Name ACES Standards Collaborators	
Answer	Yes
Document Name	
<b>Comment</b>	
Likes 0	
Dislikes 0	
<b>Response</b>	

Question 9

**James Anderson - CMS Energy - Consumers Energy Company - 1,3,4,5**

**Answer** Yes

**Document Name**

**Comment**

Likes 0

Dislikes 0

**Response**

**Michael Buyce - City Utilities of Springfield, Missouri - 1**

**Answer** Yes

**Document Name**

**Comment**

Likes 0

Dislikes 0

**Response**

**Sergio Banuelos - Tri-State G and T Association, Inc. - 1,3,5 - MRO,WECC**

**Answer** Yes

**Document Name**

**Comment**

Question 9

Likes 0

Dislikes 0

Response

Terry Harbour - Berkshire Hathaway Energy - MidAmerican Energy Co. - 1

Answer

Yes

Document Name

Comment

Likes 0

Dislikes 0

Response

Rachel Coyne - Texas Reliability Entity, Inc. - 10

Answer

Document Name

Comment

Texas RE does not have comments on this questions.

Likes 0

Dislikes 0

Response

Question 9

**Thomas Rafferty - Edison International - Southern California Edison Company - 5**

**Answer**

**Document Name**

**Comment**

Please refer to comments submitted by Robert Blackney on behalf of Southern California Edison

Likes 0

Dislikes 0

**Response**

No comments were submitted.

**Richard Vine - California ISO - 2**

**Answer**

**Document Name**

**Comment**

The California ISO supports the joint comments of the ISO/RTO Standards Review Committee

Likes 0

Dislikes 0

**Response**

Thank you for supporting the comments of the IRC Standards Review Committee (i.e., ISO/RTO Standards Review Committee).



## Question 10

10. Provide any additional comments for the SDT to consider, if desired.

Terry Harbour - Berkshire Hathaway Energy - MidAmerican Energy Co. - 1

Answer

Document Name

Comment

The approved TPL-007-1 and the current draft of TPL-007-2 includes a flowchart diagram in the Application Guides section that provides and overall view of the GMD Vulnerability Assessment process (*and the requirements in TPL-007*). There has been confusion as to which requirements are represented in the diagram. The NSRF suggest the SDT update this diagram to include annotations that identify the requirements in TPL-007-2. Please see the NSRF example which includes requirements for the benchmark and supplemental assessment.

Likes 0

Dislikes 0

Response

Thank you for your comment. The SDT did not add references to the flowchart in the Application Guidelines as the flowchart is not a one-to-one relationship with the standard requirements.

Dennis Sismaet - Northern California Power Agency - 6

Answer

Document Name

Comment

None. Thank you.

Likes 0

Dislikes 0

Response

Question 10

**Sergio Banuelos - Tri-State G and T Association, Inc. - 1,3,5 - MRO,WECC**

Answer

Document Name

Comment

Tri-State would like for some additional guidance or examples on what the SDT meant by "hardware" and "non-hardware".

Likes 0

Dislikes 0

Response

Thank you for your comment. The standard is not prescriptive in listing the various hardware and non-hardware options. Some hardware and non-hardware options are listed in Requirement R7.1.

**Marty Hostler - Northern California Power Agency - 5**

Answer

Document Name

Comment

No additional comments.

Likes 0

Dislikes 0

Response

**Richard Vine - California ISO - 2**

Answer

Question 10

Document Name

Comment

The California ISO supports the joint comments of the ISO/RTO Standards Review Committee

Likes 0

Dislikes 0

Response

Thank you for supporting the comments of the IRC Standards Review Committee (i.e., ISO/RTO Standards Review Committee).

**Brian Van Gheem - ACES Power Marketing - 6 - NA - Not Applicable, Group Name** ACES Standards Collaborators

Answer

Document Name

Comment

1. Add a comma after the “Table 1” reference within Requirement R7, as the lengthy description within the requirement describes the responsible entity and not the development of a CAP.
2. The evidence retention period demonstrating the implementation of a process to obtain GIC monitor and geomagnetic field data, as listed within R11 and R12, is identified as three calendar years. We do not see how this should be different than the evidence retention period identified for the requirements of NERC Reliability Standard TPL-001-4, which is based on the last compliance audit.
3. We thank you for this opportunity to provide these comments.

Likes 0

Dislikes 0

Response

Thank you for your comment.

1. The SDT added a comma after “Table 1” in Requirement R7.
2. The evidence retention period meets the NERC Guidelines.

Question 10

**Scott Downey - Peak Reliability - 1**

**Answer**

**Document Name**

**Comment**

While Peak supports the SDTs effort, we believe that consideration should be given to making TOPs applicable to the standard as well. Applicable TOPs are required to have operating plans for GMDs to comply with EOP-010 but without direct evaluation of TPL-007 vulnerability assessments, the plans would seem to be incomplete. Peak recognizes the requirement for proposed applicable functions to provide their vulnerability assessments to the RC but believes a more direct coordination role with the TOP should be required.

Likes 0

Dislikes 0

**Response**

Thank you for your comment. The SDT does not agree with the suggestion to make TOPs applicable entities in the standard. TPL-007 is a planning standard and applies to registered planning entities and selected asset owners. The comment is suggesting an alternative methodology to the existing standard which is outside the scope of the SDT and should be addressed in a new SAR.

**Ruida Shu - Northeast Power Coordinating Council - 1,2,3,4,5,6,7,8,9,10 - NPCC, Group Name RSC no Hydro One, HQ and IESO**

**Answer**

**Document Name**

**Comment**

On page 11 Table 1 – Note 3 should be also applicable to the row entitled “Supplemental GMD Event – GMD Event with Outages” as it relates to columns “Interruption of Firm Transmission Service Allowed” and “Load Loss Allowed”.

Likes 0

Dislikes 0

**Response**

**Question 10**

Thank you for your comment. The SDT asserts that because a CAP is not required, the additional footnote is not applicable.

**Thomas Rafferty - Edison International - Southern California Edison Company - 5**

**Answer**

**Document Name**

**Comment**

Please refer to comments submitted by Robert Blackney on behalf of Southern California Edison

Likes 0

Dislikes 0

**Response**

No comments were submitted.

**David Ramkalawan - Ontario Power Generation Inc. - 5**

**Answer**

**Document Name**

**Comment**

OPG does not agree with the implementation deadlines:

- 1) The four years deadline to implement all the hardware mitigation action may provide unfair market advantage to the unaffected/ less affected TOP, GOP due to the time/resources/financial effort involved. Continued operation should be allowed if there is a shortage of hardware, or the lead time to design/procure/implement complete hardware solution exceeds the four years duration.
- 2) TPL-007-2 should also be applicable as a Functional Entity to Generator Operator (GOP). The implementation of hardware mitigating actions may require the revision of the existing approved GIC mitigation operating procedure instructions (same if the non-hardware mitigation requires operating procedures revisions). The commissioning of the mitigating actions will also require coordination's between the TOP and GOP. GOP should be a stakeholder regarding the configuration impact and determination of affected transformers. Additionally alternative operating configuration may requires design studies involving/requiring GOP support before implementation.

**Question 10**

3) The two years deadline to implement all the non-hardware solution may provide unfair market advantage to the unaffected/less affected TOP, GOP, as the implementation for a large scale TOP, GOP will take more time, resources/financial effort and may require commissioning and studies.

Likes 0

Dislikes 0

**Response**

Thank you for your comment.

1. It is anticipated that the actual implementation (trigger to activate) of the CAP that includes operational procedure would only occur during a GMD/GIC event of sufficient size as determined by the assessment. Since GMD events are very rare, there is less likelihood that market impacts would occur as compared to a 'regular' transmission outage or constraint not related to GMD mitigation.
2. The GOPs may be involved with the execution of the CAP, as suggested in the comment, but that does not mean that the GOP should be an applicable entity in the standard.
3. See response to 1 above.

**Pamela Hunter - Southern Company - Southern Company Services, Inc. - 1,3,5,6 - SERC, Group Name Southern Company**

**Answer**

**Document Name**

**Comment**

Table 1 in the standard, under the "Steady State:" heading, part a, the sentence should be expanded as follows: "Voltage collapse, Cascading, and uncontrolled islanding shall not occur for the Benchmark GMD event, but can occur for the Supplemental GMD event subject to additional analysis specified in R8.3.

Also, verbiage in R8.3 should be expanded to include references to Voltage collapse and uncontrolled islanding

Likes 0

Dislikes 0

**Response**

## Question 10

Thank you for your comment. The SDT does not agree with the suggestion. Voltage collapse, Cascading, and uncontrolled is not allowed in either the benchmark or supplemental assessments. The distinction in R8.3 is that a CAP is not required in the case of the supplemental assessment.

**Colby Bellville - Colby Bellville On Behalf of: Dale Goodwine, Duke Energy , 6, 5, 3, 1; - Colby Bellville, Group Name Duke Energy**

**Answer**

**Document Name**

**Comment**

Duke Energy requests further clarification regarding the 90 calendar day timeframe outlined in R4. The current language states that the Responsible Entity must provide its benchmark GMD Vulnerability Assessment to the RC, adjacent PC, and adjacent TP within 90 calendar days of completion. Clarification is needed as to what date the term “completion” is referring to. Many entities may have 3rd parties conduct these studies, and in doing so, the Responsible Entity will review the study and make corrections where necessary. Is the completion date referred to in the requirement referring to the date the initial study (by the 3rd party) is completed, or is it referring to the date that the Responsible Entity has completed its internal review and obtained signoff by management? If the drafting team’s intent was for the completion date to refer to the date that the initial study was performed, we cannot agree with the 90 calendar day timeframe. Additional time would be needed for the Responsible Entity to perform its review of the 3rd party study, and obtain management signoff.

Likes 0

Dislikes 0

**Response**

Thank you for your comment. The SDT believes that the completion date is the date when the Responsible Entity considers it complete; that is, it has completed all internal reviews and management approvals.

**Eric Shaw - Eric Shaw On Behalf of: Lee Maurer, Oncor Electric Delivery, 1; - Eric Shaw**

**Answer**

**Document Name**

**Comment**

Question 10

None

Likes 0

Dislikes 0

Response

Rachel Coyne - Texas Reliability Entity, Inc. - 10

Answer

Document Name

Comment

Although not necessarily in the scope of this project, Texas RE noticed a few other things.

- There could be some clarity in which earth models are supposed to be used. The “earth model” physiographic regional maps supplied and referenced are not detailed enough to indicate the physical locations of the regional conductivity map boundaries. This lack of detail will be a source of confusion if a transformer is located near a conductivity boundary. What earth model value does the responsible entity use? If there are 3 regional conductivity areas in one responsible entity’s planning area, what earth model value does the responsible entity use?
- Texas RE is concerned the lack of a timeframe to provide GIC flow information in Requirements R5 and R9 could lead to an entity not providing GIC flow information when that information is necessary for the thermal impact assessments. Texas RE requests the SDT add a timeframe for providing the data.
- Although R1 states the PCs and TPs will identify the individual and joint responsibilities for maintaining models and performing the studies needed to complete the benchmark and supplemental GMD Vulnerability Assessments, there does not appear to be any coordination while actually performing these tasks. Texas RE is concerned this could lead to TPs each doing their own studies and coming to different conclusions, which would not allow entities to recognize vulnerabilities effectively. Texas RE recommends the PC do an overall assessment every 60 calendar months.

Likes 0



## Question 10

Dislikes 0

**Response**

Thank you for your comment. The NERC GMD Task Force whitepaper, GIC Application Guide, published December 2013, ([http://www.nerc.com/comm/PC/Pages/Geomagnetic-Disturbance-Task-Force-\(GMDTF\)-2013.aspx](http://www.nerc.com/comm/PC/Pages/Geomagnetic-Disturbance-Task-Force-(GMDTF)-2013.aspx)) discusses the use of available earth conductivity models in performing the required calculations.

The SDT is reluctant to set deadlines for the issuance of GIC calculations because the level of effort will vary widely in the various systems in North America. As an alternative, significant time has been allowed in the implementation plan to do the assessments required by R6 and R10.

The purpose of R1 is to ensure that the roles and responsibilities are clear to all, including how the PC will fit the pieces together if there are a number of entities contributing to an overall assessment.

**Kenya Streeter - Edison International - Southern California Edison Company - 6****Answer****Document Name****Comment**

Please refer to comments submitted by Robert Blackney on behalf of Southern California Edison.

Likes 0

Dislikes 0

**Response**

No comments were submitted.

**Karie Barczak - DTE Energy - Detroit Edison Company - 3****Answer****Document Name****Comment**

Question 10

no

Likes 0

Dislikes 0

Response

Dana Klem - MRO - 1,2,3,4,5,6 - MRO, Group Name MRO NSRF

Answer

Document Name

Comment

The approved TPL-007-1 and the current draft of TPL-007-2 includes a flowchart diagram in the Application Guides section that provides and overall view of the GMD Vulnerability Assessment process (*and the requirements in TPL-007*). There has been confusion as to which requirements are represented in the diagram. The NSRF suggest the SDT update this diagram to include annotations that identify the requirements in TPL-007-2. Please see example below which includes requirements for the benchmark and supplemental assessment.

Likes 1

Darnez Gresham, N/A, Gresham Darnez

Dislikes 0

Response

Thank you for your comment. The SDT did not add references to the flowchart in the Application Guidelines as the flowchart is not a one-to-one relationship with the standard requirements.

Sandra Shaffer - Berkshire Hathaway - PacifiCorp - 6

Answer

Document Name

Comment

Question 10

“PacifiCorp requests the drafting team add to the white paper links to the resources where geomagnetic field data from the magnetometers inside NERC footprint is publicly available.”

Likes 0

Dislikes 0

**Response**

Thank you for your comment. The government entity magnetometer station data is available at: US-- <https://geomag.usgs.gov/>; Canada-- <http://geomag.nrcan.gc.ca/lab/default-en.php>. The SDT will add those links to the whitepaper as the comment suggests.

**Romel Aquino - Edison International - Southern California Edison Company - 3**

Answer

Document Name

**Comment**

Please refer to comments submitted by Robert Blackney on behalf of Southern California Edison.

Likes 0

Dislikes 0

**Response**

No comments were submitted.

**Michelle Amarantos - APS - Arizona Public Service Co. - 1**

Answer

Document Name

**Comment**

AZPS is concerned that the proposed revisions to Requirement R1 to add references to the need for processes related to obtaining GMD data is inconsistent with respect to how such data is defined in later requirements, e.g., Requirements R11 and R12, and creates confusion relative

## Question 10

to the need and use of such data and to which data-related actions and requirements Requirement R1 applies. For these reasons, AZPS proposes the following revisions to ensure clarity:

**R1.** Each Planning Coordinator, in conjunction with its Transmission Planner(s), shall identify the individual and joint responsibilities of the Planning Coordinator and Transmission Planner(s) in the Planning Coordinator's planning area for maintaining models, **including the data-related processes identified in Requirements R9, R11, and R12 in this standard, and**, performing the study or studies needed to complete benchmark and supplemental GMD Vulnerability Assessments. *[Violation Risk Factor: Lower] [Time Horizon: Long-term Planning]*

Likes 0

Dislikes 0

## Response

Thank you for your comment. The SDT has revised the blue rationale box for Requirements R11 and R12 to raise awareness of the differences in the data.

**Mike Smith - Manitoba Hydro - 1, Group Name** Manitoba Hydro

Answer

Document Name

## Comment

The standard doesn't talk about how to develop equivalents of neighbouring systems and what assumptions to make. Is there only a GMD event impacting your assessment area and none in neighbouring areas?

Likes 0

Dislikes 0

## Response

Thank you for your comment. Guidance on modeling is contained in the following guides published by the NERC GMD Task Force: GIC Application Guide, September 2013 and GMD Planning Guide, December 2013 (see: [http://www.nerc.com/comm/PC/Pages/Geomagnetic-Disturbance-Task-Force-\(GMDTF\)-2013.aspx](http://www.nerc.com/comm/PC/Pages/Geomagnetic-Disturbance-Task-Force-(GMDTF)-2013.aspx))

**Daniel Grinkevich - Con Ed - Consolidated Edison Co. of New York - 1**

## Question 10

Answer

Document Name

Comment

On page 11 Table 1 – Note 3 should be also applicable to the row entitled “Supplemental GMD Event – GMD Event with Outages” as it relates to columns “Interruption of Firm Transmission Service Allowed” and “Load Loss Allowed”.

Likes 0

Dislikes 0

Response

Thank you for your comment. The SDT asserts that because a CAP is not required, the additional footnote is not applicable.

Thomas Foltz - AEP - 5

Answer

Document Name

Comment

The language used for Measure M5 was adjusted incorrectly as it currently states “... *that it has provided the maximum effective **benchmark** GIC value to the Transmission Owner and Generator.....* “. This is an incorrect statement and should instead state “...*that it has provided the maximum effective GIC value **under the benchmark event** to the Transmission Owner and Generator.....*”

While AEP supports the overall effort of the drafting team, AEP has chosen to vote "no" driven by the lack of clarity related to the potential duplication of efforts related to assets which are in-scope for both the benchmark and supplemental assessments. Similarly, AEP is concerned by the overall burden associated with having a secondary suite of “parallel requirements” to accommodate the supplemental assessment.

Likes 0

Dislikes 0

Response

## Question 10

Thank you for your comment. The SDT removed “benchmark” in Measure M5 and a conforming change by removing “supplemental” in Measure M9. The SDT purposely is requesting two separate thermal assessments be done for transformers that exceed the GIC thresholds: One for the benchmark event and one for the supplemental event. The supplemental assessment is intended to address local enhancements. The benchmark assessment may result in a Corrective Action Plan, but the supplemental assessment does not.

**Kristine Ward - Seminole Electric Cooperative, Inc. - 1,3,4,5,6 - FRCC**

**Answer**

**Document Name**

**Comment**

Comments:

1. Parallels between R4 and R8:

It appears that the standard is now requiring applicable entities to perform two GMD Vulnerability assessments (benchmark and supplemental), either at the same time, or within 5 years or less of each other. This seems to be duplicative and should be characterized as a sensitivity to the benchmark and done at the same time if required or be performed as part of “subsequent” assessments. Also on that note, the supplemental assessment has an additional requirement (R8.3) to determine if Cascading occurs, where the benchmark assessment does not. Cascading is often required to be determined via stability analysis which is outside the scope of TPL-007-2 because the standard as written only requires steady state/load flow analysis. Can the SDT please elaborate on this shift in requiring entities to evaluate Cascading in the supplemental assessment and not in the benchmark assessment, as well as elaborate on the need to evaluate Cascading as a whole? Also, the requirement of having to provide the completed assessment to the applicable entities, rather than just making it available (as originally drafted), is not providing any reliability benefit other than paperwork for the entities, I thought Paragraph 81 was initiated to get away from such requirements and here we are putting them right back in.

1. R7.3.1,7.3.2:

What does the SDT envision as a “non-hardware” mitigation vs. a hardware mitigation?

1. R4, R8

Why does the SDT feel it necessary to add the phrase “at least” in the requirements associated with subsequent GMD assessments? The existing language, without the insert, does not preclude an entity from performing an assessment sooner than the 60 calendar months if the entity determines it necessary, the insert of “at least” provides no added benefit or clarity to the existing language.

1. Applicable Facilities:

## Question 10

Has the SDT given any consideration to clarifying the applicable Facilities within TPL-007-2? The standard is only applicable to PCs, TOs, and GOs; however, there are transformers that are wye-grounded on the high-voltage terminals, operated at greater than 200 kV but are not owned by registered TOs or have been excluded from the BES, pursuant the BES Definition. How does the SDT plan to address those? For example, a GO can provide their respective PC with GSU information for the GMD model; however, their auxiliary transformer(s) which are connected on the high-side at 200 kV or greater and are wye-grounded are not considered BES Facilities and therefore are not required to be provided to the PC as part of their evaluation, even though the unit auxiliary transformers have the potential of tripping the entire plant.

## 1. Cost Study

Seminole requests the SDT perform a CEAP (Cost Effective Analysis Process) for this Standard. TPL-007 is a great candidate as the costs of all of the studies is substantial and the frequency of an event causing catastrophic consequences is low.

## 2. FRCC Specific TPL-007-2

Seminole requests that the SDT develop an initial low cost study that would allow for entities in the very far south to be excluded from performing further compliance measures. In the alternative, Seminole requests the SDT to note that the SDT is open to the idea of reduced requirement FRCC-specific TPL-007-2.

## 1. 7.3.1

Change the time value to 24 months instead of 2 years to stay consistent. Same with 7.3.2.

## 1. R11 Note

The Note for R11 states that the data collected via magnetometers and GIC monitoring is necessary for “situational awareness”. Does the SDT believe that the data collected for situational awareness could classify this collection equipment as BES Cyber Assets if system operators make decisions based off of this equipment within 15 minutes?

Likes	0
Dislikes	0

## Response

Thank you for your comment. The revised standard is requiring a second (supplemental) assessment to be performed coincident with the original (benchmark) assessment to explicitly account for the impacts associated with local enhancements. Since the SDT is not requiring a CAP for the supplemental assessment, it can be thought of as a sensitivity to the benchmark assessment. Cascading is not allowed in either assessment and to the degree that there is inconsistency in the wording, the SDT will make corrections. The assessments are steady state and not intended to imply dynamics analysis.

**Question 10**

The reliability benefit comes from performing a GMD vulnerability assessment using an enhanced GMD event.

Examples of hardware mitigation include equipment replacement or modification, GIC blocking devices, protection systems, etc. Examples of non-hardware mitigation include operating procedures, etc.

The SDT did not remove the phrase “at least” as suggested.

The intent of the standard is to protect the BES and therefore, the SDT does not intend to address non-BES facilities in the standard. Planning entities can choose to address other facilities in their assessments if they conclude that those facilities can have a meaningful impact to the results.

The SDT believes that it has addressed the concerns of the low latitude entities through the use of geomagnetic latitude scaling, which does not exempt entities from the requirements of performing the analyses. The state of the scientific knowledge on GMD is such that a blanket exemption from performing the analyses below certain latitudes is not prudent.

The SDT does not agree with the change from “two years” to “24 months” in 7.3.1 and 7.3.2 as suggested.

The statement in the information box associated with R11 comes from the FERC Order No. 830. It is included for information and not intended to imply any requirements in this standard. Situational awareness is a term used in operations and not applicable here.



## Resilient Societies

Comments of the Foundation for Resilient Societies on **NERC Project 2013-03 Geomagnetic Disturbance Mitigation, Transmission System Planned Performance for Geomagnetic Disturbance Events, Draft of TPL-007-2.**

We provide brief comments on the Draft Standard, Draft Implementation Plan, and Research Work Plan of NERC.

Draft **Reliability Standard TPL-007-2** is based on modeling that is substantially divorced from the empirical evidence of bulk power system equipment susceptibility to damage or total losses during moderate geomagnetic disturbances during just the past three decades.

NERC's GMD Vulnerability Assessment process lacks scientific rigor. A rigorous standard would include:

Collection of all known or likely bulk power system equipment damage or loss during all three known classes of geomagnetic disturbance: (1) **coronal mass ejections (CMEs)**, upon which NERC has concentrated; (2) more extended duration but less intense **coronal hole proton streams (CHs)**, associated with a substantially larger set of EHV transformer fires and explosions during the past three decades; and (3) **sudden commencement** or **sudden reversal GMDs**, such as occurred at Seabrook Station between November 8 and 10, 1998, with resulting meltdown of lower voltage windings in the Phase A 345 kV transformer.

**Transformer thermal impact assessments**, if performed only if the maximum effective geomagnetically induced current (GIC) in the transformer is equal or greater than 75 amps per phase for the benchmark GMD event, and 85 amps per phase for the supplemental GMD event, are imprudent and needlessly risky, for a class of equipment with replacement times measured in months or years.

Idaho National Laboratory suspended injection of quasi-DC currents into a 138 kV transformer during tests with and without attachment of a neutral ground blocker in year 2013. Why was it necessary for INL test managers to suspend the DC current injections at a level of 22 amps per phase, to avert transmission system damage, if the standard's threshold is "prudently" set at 75 amps per phase?

What is needed is a more comprehensive set of GMD classes of hazard, a sharing of data on equipment losses since at least year 1989, not year 2013, improved modeling, and widespread testing of vulnerable BES equipment both under load and to destruction. Geomagnetically Induced Current (GIC) data should be retained indefinitely, not for the 3 years specified in the draft standard, because the return period for severe solar storms can be in excess of 100 years.

NERC claims that "the respective screening criteria are **conservative...**" (NERC Thermal Screening Criterion White Paper, 2017). We dispute this claim and see no scientific foundation for it. As a result of these deficiencies, the bulk electric system remains highly

vulnerable to natural occurring geomagnetic disturbances, and more powerful high altitude electromagnetic pulse (EMP) hazards that are manmade.

Respectfully submitted by:

William R. Harris

**SDT Response:**

TPL-007 requires two distinct types of assessment. The first one is a system assessment which is determined by the largest geoelectric field estimated to occur once in 100 years. This assessment evaluates effects such as reactive power loss, voltage depression and harmonics due to the interaction of a dc (peak) geoelectric field with the power system. The second assessment looks at the thermal effects of time-varying GIC(t) on transformers. The GIC(t) waveform depends on the static GIC distribution obtained from the system assessment. The 75 A/phase and 85 A/phase screening thresholds are calculated using the benchmark and supplemental benchmark waveforms, respectively. Comparing the screening current thresholds with the constant dc injected in the INL tests is inappropriate and incorrect.

The INL tests did not monitor transformer hot spots, therefore the SDT cannot comment on conjectures regarding testing parameters used.

The NERC 1600 Data Request will address the data retention of the GIC monitor data and geomagnetic field data collected by NERC. The 3-year retention period relates to the time frame that an applicable entity must retain evidence of their processes for compliance with Requirements R11 and R12.

The SDT has used 20 years of consistent geomagnetic field measurements to estimate 1 in 100 year benchmark events regardless of the physical processes captured by the measurements.

The SDT agrees with the need to improve modelling and testing, which will be addressed with NERC's research plan.

**Comments from Avangrid**

1. The SDT developed proposed **Requirements R8 – R10** and the supplemental GMD event to address FERC concerns with the benchmark GMD event used in GMD Vulnerability Assessments. (Order No. 830 P.44, P.47-49, P.65). The requirements will obligate responsible entities to perform a supplemental GMD Vulnerability Assessment based on the supplemental GMD event that accounts for potential impacts of localized peak geoelectric fields. Do you agree with the proposed requirements? If you do not agree, or if you agree but have comments or suggestions for the proposed requirements provide your recommendation and explanation.

Yes

No

Comments:

2. The SDT developed the **Supplemental GMD Event Description white paper** to provide technical justification for the supplemental GMD event. The purpose of the supplemental GMD event description is to provide a defined event for assessing system performance for a GMD event which includes a local enhancement of the geomagnetic field. Do you agree with the proposed supplemental GMD event and the description in the white paper? If you do not agree, or if you agree but have comments or suggestions for the supplemental GMD event and the description in the white paper provide your recommendation and explanation.

Yes

No

Comments:

3. The SDT established an 85 A per phase screening criterion for determining which power transformers are required to be assessed for thermal impacts from a supplemental GMD event in Requirement R10. Justification for this threshold is provided in the revised **Screening Criterion for Transformer Thermal Impact Assessment** white paper. Do you agree with the proposed 85 A per phase screening criterion and the technical justification for this criterion that has been added to the white paper? If you do not agree, or if you agree but have comments or suggestions for the screening criterion and revisions to the white paper provide your recommendation and explanation.

Yes  
 No

Comments: "Figure 2: Metallic hot spot temperatures calculated using the benchmark GMD event" from the screening criterion document provides a useful visual, can the drafting team additionally provide a similar chart and the data for the supplemental GMD event?

**SDT Response:**

Thank you for your comment. Figure 2 in the Screening Criteria document is only an illustrative example of a GIC(t) waveform and thermal response time series would look like for the particular level of GIC and event.

The SDT agrees that accuracy of models and tools is very important and that their improvement and validation are the main drivers for the research plan. The upper bound of hot spot temperatures are provided in Figure 3 of the Screening Criterion for Transformer Thermal Impact Assessment white paper and in Tables 1 and 2 of Appendix 1 of the same document.

4. The SDT revised the **Transformer Thermal Impact Assessment white paper** to include the supplemental GMD event. Do you agree with the revisions to the white paper? If you do not agree, or if you agree but have comments or suggestions on the revisions to the white paper provide your recommendation and explanation.

Yes  
 No

Comments: Table 1 and 2 are useful to show the differences between the benchmark event and the supplemental, but some of the figures are not clear which GMD event was used to generate the gic(t) time series. Can some additional language be added to clarify the GMD event of the figures in this document?

Also, there was some inconsistency in axis labels and units between the various figures, which makes it difficult to draw conclusions when comparing the charts. For example A/phase versus Amps, minutes versus hours for the time scale. Can these charts be updated with uniform axis labels and units for comparative purposes?

**SDT Response:**

Thank you for your comment. This version of the white paper is intended to illustrate different ways to carry out thermal transformer assessments. The time series used in the white paper are based on portions of the benchmark time series and are intended for illustrative purposes only. The Figures in the white papers are sufficiently clear for their intended use.

5. The SDT developed proposed **Requirement R7** to address FERC directives in Order No. 830 for establishing **Corrective Action Plan (CAP) deadlines** associated with GMD Vulnerability Assessments (P. 101, 102). Do you agree with the proposed requirement? If you do not agree, or if you agree but have comments or suggestions for the proposed requirement provide your recommendation and explanation.

Yes

No

Comments:

6. The SDT developed Requirements **R11 and R12** to address FERC directives in Order No. 830 for requiring responsible entities to collect GIC monitoring and magnetometer data (P. 88; P. 90-92). Do you agree with the proposed requirements? If you do not agree, or if you agree but have comments or suggestions for the proposed requirements provide your recommendation and explanation.

Yes

No

Comments: Neutral current measurements are not sufficient to benchmark autotransformer performance in a GMD event; TOs would need at least two out of three leg measurements to do this. Additionally, the proxy magnetometer data leaves flexibility for the TO, but may not prove to be effective for benchmarking without other additional considerations. While the intent of the R11 requirement is to benchmark the model, without accurate magnetometer installations in each TOs footprint, it may be difficult to do so; particularly where no nearby proxy data can be leveraged. Can the drafting team consider increasing R11 further and require TOs to either install measuring devices in their area, and/or to prove the accuracy of the proxy data? Also, can the drafting team consider a requirement for additional measurements on autotransformers?

**SDT Response:**

Thank you for your comment. Requirement R11 addresses the process for data collection. The standard does not address the appropriateness of magnetometer site installation and validity of data.

7. Do you agree with the proposed **Implementation Plan for TPL-007-2**? If you do not agree, or if you agree but have comments or suggestions for the Implementation Plan provide your recommendation and explanation.

Yes

No

Comments:

8. Do you agree with the **Violation Risk Factors (VRFs) and Violation Severity Levels (VSLs)** for the requirements in proposed TPL-007-2? If you do not agree, or if you agree but have comments or suggestions for the VRFs and VSLs provide your recommendation and explanation.

Yes

No

Comments:

9. The SDT believes proposed TPL-007-2 provide entities with flexibility to meet the reliability objectives in the project Standards Authorization Request (SAR) in a cost effective manner. Do you agree? If you do not agree, or if you agree but have suggestions for improvement to enable additional cost effective approaches to meet the reliability objectives, please provide your recommendation and, if appropriate, technical justification.

Yes

No

Comments:

10. Provide any additional comments for the SDT to consider, if desired.

Comments:

## Attachment 1

### SPP TPLTF Review of TPL-007-2 Comment Questions published by Project 2013-03 (Geomagnetic Disturbance Mitigation)

In July 2017, the Project 2013-03 Standard Drafting Team (SDT) released an unofficial comment form to allow the industry to provide feedback on the proposed TPL-007-2 – Transmission System Planned Performance for Geomagnetic Disturbance Events standard. It is noted that the industry comment period is brief and all comments must be submitted by Friday, August 11, 2017. Given that the SPP TPLTF has been actively developing guidance and processes for SPP and its members to address the approved TPL-007-1 standard, this open comment period offered an opportunity for the TPLTF to collectively review the proposed standard. Further, the TPLTF assessed the TPL-007-2 official comment questionnaire and discussed potential industry responses. The following represents a summary of the informal discussion conducted by the TPLTF and is provided to add value to those SPP members who choose to submit comments during the open period. The information given here should be considered non-binding and is intended to supplement independent reviews of the proposed TPL-007-2, thereby adding the value of a TPLTF perspective.

If you have any questions, please contact the SPP TPLTF secretary Scott Jordan (SPP staff, [sjordan@spp.org](mailto:sjordan@spp.org)) or the SPP TPLTF chairperson Chris Colson (WAPA-UGPR, [colson@wapa.gov](mailto:colson@wapa.gov)).

General comment: Upon the TPLTF review of FERC Order No. 830, released in September 2016, it is clear that the FERC directives are very prescriptive. The group felt that there was little leeway offered the Project 2013-03 in drafting the proposed TPL-007-2 changes. Knowing this, the TPLTF review focused on the SDT approach to meeting the directives of FERC Order No. 830 and its impact upon the SPP Planning Coordinator, as well as SPP member Transmission Planners, Transmission Owners, and Generator Owners. The TPLTF took particular care to focus upon the draft requirements of TPL-007-2 and attempted to omit any discussion of the FERC directives themselves, given that they are established in Order No. 830.

#### Questions from the TPL-007-2 Comment Form

1. The SDT developed proposed Requirements R8 – R10 and the supplemental GMD event to address FERC concerns with the benchmark GMD event used in GMD Vulnerability Assessments. (Order No. 830 P.44, P.47-49, P.65). The requirements will obligate



responsible entities to perform a supplemental GMD Vulnerability Assessment based on the supplemental GMD event that accounts for potential impacts of localized peak geoelectric fields. Do you agree with the proposed requirements? If you do not agree, or if you agree but have comments or suggestions for the proposed requirements provide your recommendation and explanation.

TPLTF Discussion: The group agrees with the SDT approach to addressing FERC Order No. 830

Paragraph 44. In effect, the SDT has specified an extreme value for geoelectric field, called the supplemental GMD event, intended to represent a locally-enhanced geoelectric field experienced by a limited geographic area. In other words, the SDT has proposed a means by which Planning Coordinators and Transmission Planners can approximate a non-geospatially-averaged peak geoelectric field, thus meeting the intent of the FERC Order No. 830 directive. While determining peak geoelectric field amplitudes not based solely on spatially-averaged data is a significant challenge to meeting the FERC directive, primarily because of the lack of North American data, as well as analytical tools available to Planning Coordinators and Transmission Planners, the group believes the SDT has found a workable approach.

The group would like to note that it will be non-trivial to apply the localized peak geoelectric field in the supplemental GMD event to a spatially-limited area, described in the proposed TPL-007-2

Attachment 1, given available software tools and available personnel resources. This will be especially pronounced for Planning Coordinators and Transmission Planners with large geographical footprints. Many planning entities will be forced to apply the supplemental peak geoelectric field over their entire area, in effect simply studying a higher magnitude benchmark GMD event. While the group believes this is prominently conservative, as stated above, we understand and support the SDT approach to this directive. It is likewise noted that the definition of a spatially-limited area is absent in the materials published by the SDT, but this vagary supports better analytical flexibility for Planning Coordinators and Transmission Planners and should not be defined in the draft standard.

2. The SDT developed the *Supplemental GMD Event Description* white paper to provide technical justification for the supplemental GMD event. The purpose of the supplemental GMD event description is to provide a defined event for assessing system performance for a GMD event which includes a local enhancement of the geomagnetic field. Do you agree with the proposed supplemental GMD event and the description in the white paper? If you do not agree, or if you agree but have comments or suggestions for the supplemental GMD event and the description in the white paper provide your recommendation and explanation.

TPLTF Discussion: The group recognizes that there are multiple methods to approach revisions to the benchmark GMD event definition so that the reference peak geoelectric field amplitude component is not based solely on spatially-averaged data (FERC Order No. 830 Paragraph 44). However, given a wide diversity in available data, analytical tools, and personnel expertise, the group believes that the SDT has found a practical approach to meeting the objective of the FERC directive. Moreover, the *Supplemental GMD Event Description* white paper presents a reasoned justification for the use of the geoelectric field amplitude of 12 V/km.

The group recommends that the SDT consider a less ambiguous name for the Supplemental GMD Event; the group believes *Extreme Value GMD Event* would be more appropriate for the following reasons:

- a. Implies a closer relationship to the extreme events of TPL-001-4 for which Planning Coordinators and Transmission Planners are familiar.
- b. Is better aligned with the extreme value statistical analysis that was conducted to produce the subject reference peak geoelectric field amplitude.
- c. Indicates a measure of how rare the extreme value for the 1-in-100 year peak geoelectric field amplitude may be, based upon the 95% confidence interval of the extreme value.

While the group agrees that the application of extreme value statistical methods presented in the *Supplemental GMD Event Description* white paper is sound, three clarifying statements should be made in the white paper. Firstly, in short, the group agrees that by using the 23 years of daily maximum geoelectric field amplitudes from IMAGE magnetometers, a proxy of higher magnitude events can be characterized. It is noted that the southernmost magnetometer in the IMAGE chain resides in Suwałki, Poland at 54.01°N, whose geographic latitude places it roughly 500 miles north of Quebec. Given that geoelectric field is highly correlated with geomagnetic latitude rather than geographic latitude, the IMAGE data should still be referred to as a loose approximation for estimated North American geoelectric field magnitudes (Suwałki, Poland geomagnetic dipole latitude 52°N, Quebec geomagnetic dipole latitude 56°N). In other words, the group believes it is appropriate to qualify that the extreme value analysis performed in the white paper is based upon maximum data points obtained from an array of northern geomagnetically-biased latitudes, further inflated by using the high earth conductivity of Quebec. Secondly, it is well known that coastal geological conditions can lead to locally-enhanced geoelectric fields, not observed in regions more distant from the coast. Given that nearly all of the IMAGE chain

magnetometers reside within 100 miles of the northern Atlantic Ocean or Baltic Sea coasts, it is reasonable to conclude that the geoelectric field amplitudes derived from the corresponding IMAGE data may have suffered from geoelectric field enhancement along conductivity boundaries. With respect to serving as a proxy for mainland North American peak geoelectric field amplitude, the SDT should consider further qualifying the appropriateness of the IMAGE data which served as the foundation of the extreme value analysis. Finally, the group agrees that the use of more resolute point over threshold (POT) methods was indicated over generalized extreme value (GEV). For clarity, however, it should be emphasized that the geoelectric field amplitude of 12 V/km represents the *extreme value* of the upper limit of the 95 percent confidence interval for a 100-year return interval. In other words, the statistical significance of the extreme value confidence interval is not equivalent to the statistic expressed by the confidence interval for the data set consisting of 23 years of all sampled geoelectric field amplitudes (not shown). Each of these considerations, if addressed, can strengthen the conclusions of the white paper by emphasizing its conservative approach.

3. The SDT established an 85 A per phase screening criterion for determining which power transformers are required to be assessed for thermal impacts from a supplemental GMD event in Requirement R10. Justification for this threshold is provided in the revised *Screening Criterion for Transformer Thermal Impact Assessment* white paper. Do you agree with the proposed 85 A per phase screening criterion and the technical justification for this criterion that has been added to the white paper? If you do not agree, or if you agree but have comments or suggestions for the screening criterion and revisions to the white paper provide your recommendation and explanation.

TPLTF Discussion: Given the use of the 12 V/km geoelectric field amplitude for the supplemental GMD event, the group agrees with the proposed 85 Amp threshold justified in the *Screening Criterion for Transformer Thermal Impact Assessment* white paper. The group suggests that the proposed change on page 11 of the white paper stating “because the supplemental waveform has a sharper peak, the peak metallic hot spot temperatures associated with the supplemental waveform are slightly lower than those associated with the benchmark waveform” be clarified. In other words, this statement is counterintuitive given that the increased supplemental time-series waveform peak value implies higher GIC flows that, when experienced by a transformer will lead potentially higher metallic hot spot temperatures. A suggested approach to better communicate this point is as follows:

Given that GICs are proportional to the time-varying electric field, according to:

$$GIC(t) = |E(t)| \cdot [GIC_{Easterly} \sin \varphi(t) + GIC_{Northerly} \cos \varphi(t)] \quad (1)$$

The joule heating effect in transformers is proportional to the time-varying GIC, as:

$$\frac{dQ}{dt} \propto GIC(t)^2, \text{ where } P(t) = I(t)^2 R, Q = \int P(t) dt \quad (2)$$

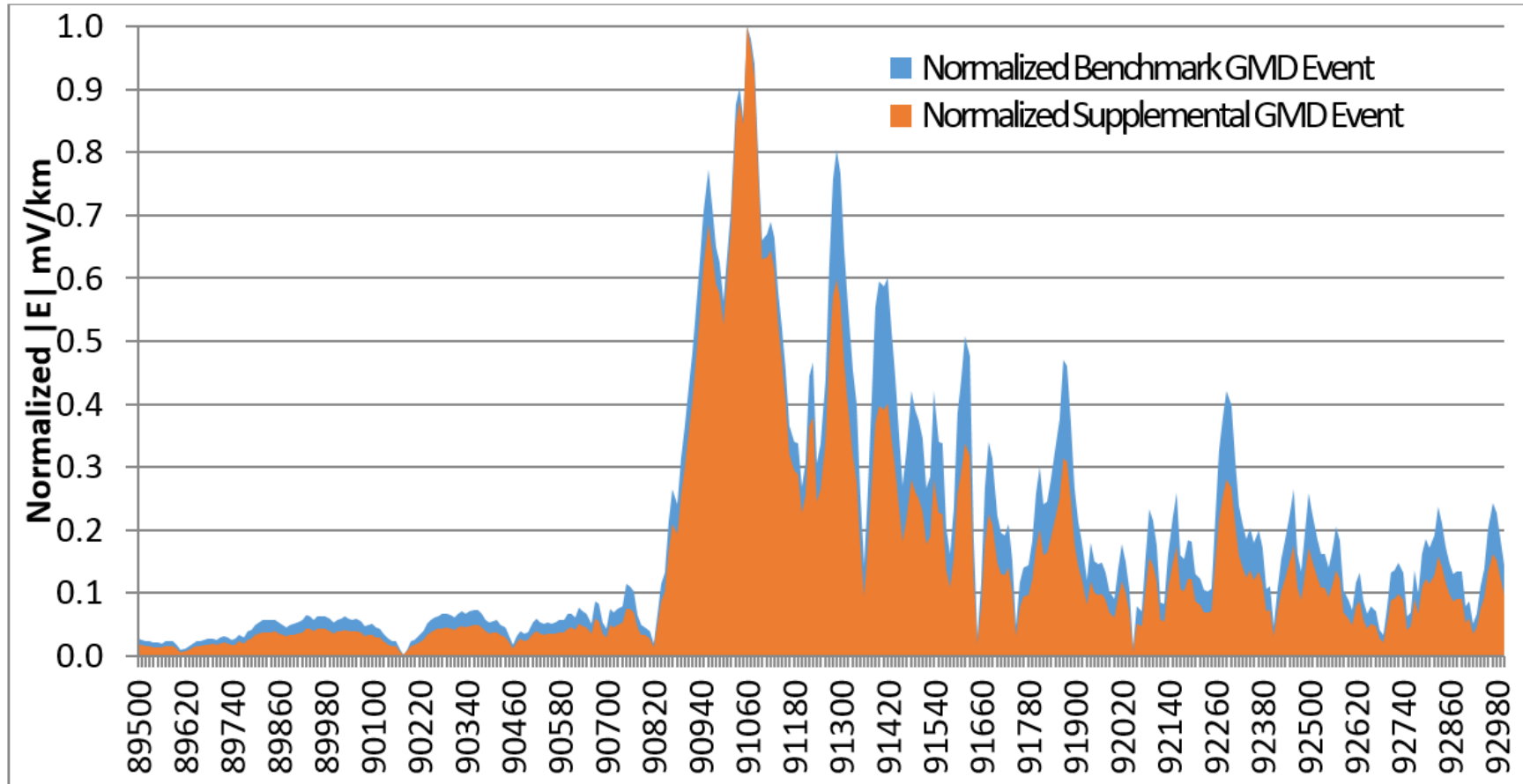
It follows that the transformer metallic hot spot temperature is proportional to the time-varying GIC, as:

$$T_F \propto \int GIC(t) dt, \text{ given } T_0 \quad \text{where } \frac{dQ}{dt} = c_P m \frac{dT}{dt} \quad (3)$$

Therefore, the corresponding proportion that relates the transformer metallic hot spot temperature to time-varying geoelectric field amplitude is expressed by:

$$T_{\text{metallic hot spot}} \propto \int E(t) dt \quad (4)$$

The figure below shows the benchmark GMD and supplemental GMD event waveforms normalized to their respective geoelectric field peak amplitudes. By portraying the two events in this manner, it is evident that the relationship given in (4) leads to a proxy heating quantity for the benchmark GMD event approximately 32% more than the supplemental GMD event. Even though the peak GIC induced by the supplemental GMD is higher than the benchmark, the total heating is less (integral).



In other words, if the peak transformer GIC screening threshold were 75 A/phase for both events, the transformer suffering a supplemental GMD event would experience less overall heating; the aggregated effects of the Supplemental geoelectric field “intensity” is not sustained. Thus, the screening threshold for supplemental GMD event transformer GIC is established at a slightly higher, but conservative, 85A/phase.

4. The SDT revised the *Transformer Thermal Impact Assessment* white paper to include the supplemental GMD event. Do you agree with the revisions to the white paper? If you do not agree, or if you agree but have comments or suggestions on the revisions to the white paper provide your recommendation and explanation.

TPLTF Discussion: The group agrees with the changes in the *Transformer Thermal Impact Assessment* white paper, with the exception of the explanation provided for Table 2 on page 5. Similar to the comment made regarding the counterintuitive language in the *Screening Criterion for Transformer Thermal Impact Assessment* white paper, it is not clear why metallic hot spot temperatures are reduced for the supplemental GMD event for the same effective GIC and transformer bulk oil temperature. Additional clarity on this point would improve the ability of applicable entities to rely upon the reference data provided. The group recommends adding white paper language similar to that suggested in Question Q3.

The group would like to highlight that the study of supplemental GMD event conditions may cause a significantly larger number of transformers to be added for assessed by Transmission Owners and Generator Owners. Given that the analytical tools and modeling software available for this type of analysis are limited, as well as the fact that most manufacturers supplying power transformers to U.S. customers do not include data necessary to complete detailed thermal modeling with transformer test reports, the additional effort to satisfy the supplemental GMD event analysis will be arduous. The group recommends that the SDT consider the reality that these tools are merely in their infancy across the industry, and additional time to develop, deploy, and train on them should be included in the TPL-007-2 implementation plan to complete transformer thermal assessments for the supplemental GMD event.

5. The SDT developed proposed Requirement R7 to address FERC directives in Order No. 830 for establishing Corrective Action Plan (CAP) deadlines associated with GMD Vulnerability Assessments (P. 101, 102). Do you agree with the proposed requirement? If you do not agree, or if you agree but have comments or suggestions for the proposed requirement provide your recommendation and explanation.

TPLTF Discussion: Given the specificity of the Paragraphs 101 and 102 directives of FERC Order No. 830 Paragraph 44, the group believes that the SDT had little flexibility when developing the proposed language of Requirement R7. The group agrees with the proposed Requirement R7, as presented. The group would like to reiterate the suggestion that the

Supplemental GMD Event nomenclature be changed to Extreme Value GMD Event, as explained in the group's discussion of Question Q2.

6. The SDT developed Requirements R11 and R12 to address FERC directives in Order No. 830 for requiring responsible entities to collect GIC monitoring and magnetometer data (P. 88; P. 90-92). Do you agree with the proposed requirements? If you do not agree, or if you agree but have comments or suggestions for the proposed requirements provide your recommendation and explanation.

TPLTF Discussion: Despite the added cost to implement additional monitoring and data collection, the group agrees that the SDT developed a reasonable approach to the FERC directives in Order No. 830 Paragraph 88.

7. Do you agree with the proposed Implementation Plan for TPL-007-2? If you do not agree, or if you agree but have comments or suggestions for the Implementation Plan provide your recommendation and explanation.

TPLTF Discussion: The group agrees with the proposed Implementation Plan for TPL-007-2 and does not see any conflicts with the order by which the phased requirements become effective. However, given the lack of available tools, absence of thermal modeling-related data from transformer manufacturers, and the significant training that will be necessary to properly execute transformer thermal assessments, the group believes that the implementation period for Requirement R10 should be at least 48 months after the standard is approved. This suggested implementation period is consistent with the existing implementation period for Requirement R6 (transformer thermal assessment for benchmark GMD event) and should allow sufficient time for many more transformers that may be observed to exceed the supplemental GMD event screening criterion.

8. Do you agree with the Violation Risk Factors (VRFs) and Violation Severity Levels (VSLs) for the requirements in proposed TPL-007-2? If you do not agree, or if you agree but have comments or suggestions for the VRFs and VSLs provide your recommendation and explanation.

TPLTF Discussion: The group agrees with the apportionment of the VRFs and VSLs.

9. The SDT believes proposed TPL-007-2 provide entities with flexibility to meet the reliability objectives in the project Standards Authorization Request (SAR) in a cost effective manner. Do you agree? If you do not agree, or if you agree but have suggestions for improvement to enable additional cost effective approaches to meet the reliability objectives, please provide your recommendation and, if appropriate, technical justification.

TPLTF Discussion: The group agrees that the SDT has done a good job of considering cost in time, resources, and personnel commitment in meeting the objectives of the SAR, which were heavily prescribed by FERC Order No. 830. The group may not agree with the perceived benefit to reliability that the additional effort to analyze the supplemental GMD event will yield, but the SDT has proposed a solid means of addressing the FERC directives without relying on tools or methods that do not exist widely in industry today. The group also supports the SDT cost-effective approach to the proposed Requirement R7 which does not mention GIC blocking devices as an integral part of a hardware mitigation. The group remains concerned with the perception that GIC mitigation hardware is presently a viable solution. Given its cost, effects on Protection System design, as well as potential compromises to existing BES reliability, GIC blocking devices may prove undesirable. The flexibility that the SDT has proposed in the development of Corrective Action Plans is workable.

10. Provide any additional comments for the SDT to consider, if desired.

TPLTF Discussion: None additional.



## Standard Development Timeline

This section is maintained by the drafting team during the development of the standard and will be removed when the standard is adopted by the NERC Board of Trustees (Board).

### Description of Current Draft

Completed Actions	Date
Standards Committee approved Standard Authorization Request (SAR) for posting	December 14, 2016
SAR posted for comment	December 16, 2016 – January 20, 2017
45-day formal comment period with initial ballot	June 28 – August 11, 2017

Anticipated Actions	Date
10-day final ballot	October 2017
Board adoption	November 2017

## **New or Modified Term(s) Used in NERC Reliability Standards**

This section includes all new or modified terms used in the proposed standard that will be included in the *Glossary of Terms Used in NERC Reliability Standards* upon applicable regulatory approval. Terms used in the proposed standard that are already defined and are not being modified can be found in the *Glossary of Terms Used in NERC Reliability Standards*. The new or revised terms listed below will be presented for approval with the proposed standard. Upon Board adoption, this section will be removed.

**Term(s):**

None

Upon Board adoption, the rationale boxes will be moved to the Supplemental Material Section.

## A. Introduction

1. **Title:** Transmission System Planned Performance for Geomagnetic Disturbance Events
2. **Number:** TPL-007-2
3. **Purpose:** Establish requirements for Transmission system planned performance during geomagnetic disturbance (GMD) events.
4. **Applicability:**
  - 4.1. **Functional Entities:**
    - 4.1.1. Planning Coordinator with a planning area that includes a Facility or Facilities specified in 4.2;
    - 4.1.2. Transmission Planner with a planning area that includes a Facility or Facilities specified in 4.2;
    - 4.1.3. Transmission Owner who owns a Facility or Facilities specified in 4.2; and
    - 4.1.4. Generator Owner who owns a Facility or Facilities specified in 4.2.
  - 4.2. **Facilities:**
    - 4.2.1. Facilities that include power transformer(s) with a high side, wye-grounded winding with terminal voltage greater than 200 kV.
5. **Effective Date:** See Implementation Plan for TPL-007-2.
6. **Background:** During a GMD event, geomagnetically-induced currents (GIC) may cause transformer hot-spot heating or damage, loss of Reactive Power sources, increased Reactive Power demand, and Misoperation(s), the combination of which may result in voltage collapse and blackout

## B. Requirements and Measures

- R1. Each Planning Coordinator, in conjunction with its Transmission Planner(s), shall identify the individual and joint responsibilities of the Planning Coordinator and Transmission Planner(s) in the Planning Coordinator's planning area for maintaining models, performing the study or studies needed to complete benchmark and supplemental GMD Vulnerability Assessments, and implementing process(es) to obtain GMD measurement data as specified in this standard. [*Violation Risk Factor: Lower*] [*Time Horizon: Long-term Planning*]

- M1.** Each Planning Coordinator, in conjunction with its Transmission Planners, shall provide documentation on roles and responsibilities, such as meeting minutes, agreements, copies of procedures or protocols in effect between entities or between departments of a vertically integrated system, or email correspondence that identifies an agreement has been reached on individual and joint responsibilities for maintaining models, performing the study or studies needed to complete benchmark and supplemental GMD Vulnerability Assessments, and implementing process(es) to obtain GMD measurement data in accordance with Requirement R1.
- R2.** Each responsible entity, as determined in Requirement R1, shall maintain System models and GIC System models of the responsible entity’s planning area for performing the study or studies needed to complete benchmark and supplemental GMD Vulnerability Assessments. *[Violation Risk Factor: High] [Time Horizon: Long-term Planning]*
- M2.** Each responsible entity, as determined in Requirement R1, shall have evidence in either electronic or hard copy format that it is maintaining System models and GIC System models of the responsible entity’s planning area for performing the study or studies needed to complete benchmark and supplemental GMD Vulnerability Assessments.
- R3.** Each responsible entity, as determined in Requirement R1, shall have criteria for acceptable System steady state voltage performance for its System during the GMD events described in Attachment 1. *[Violation Risk Factor: Medium] [Time Horizon: Long-term Planning]*
- M3.** Each responsible entity, as determined in Requirement R1, shall have evidence, such as electronic or hard copies of the criteria for acceptable System steady state voltage performance for its System in accordance with Requirement R3.

**Benchmark GMD Vulnerability Assessment(s)**

- R4.** Each responsible entity, as determined in Requirement R1, shall complete a benchmark GMD Vulnerability Assessment of the Near-Term Transmission Planning Horizon at least once every 60 calendar months. This benchmark GMD Vulnerability Assessment shall use a study or studies based on models identified in Requirement R2, document assumptions, and document summarized results of the steady state analysis. *[Violation Risk Factor: High] [Time Horizon: Long-term Planning]*
  - 4.1.** The study or studies shall include the following conditions:
    - 4.1.1.** System On-Peak Load for at least one year within the Near-Term Transmission Planning Horizon; and
    - 4.1.2.** System Off-Peak Load for at least one year within the Near-Term Transmission Planning Horizon.

- 4.2.** The study or studies shall be conducted based on the benchmark GMD event described in Attachment 1 to determine whether the System meets the performance requirements for the steady state planning benchmark GMD event contained in Table 1.
- 4.3.** The benchmark GMD Vulnerability Assessment shall be provided: (i) to the responsible entity's Reliability Coordinator, adjacent Planning Coordinators, and adjacent Transmission Planners within 90 calendar days of completion, and (ii) to any functional entity that submits a written request and has a reliability-related need within 90 calendar days of receipt of such request or within 90 calendar days of completion of the benchmark GMD Vulnerability Assessment, whichever is later.
- 4.3.1.** If a recipient of the benchmark GMD Vulnerability Assessment provides documented comments on the results, the responsible entity shall provide a documented response to that recipient within 90 calendar days of receipt of those comments.
- M4.** Each responsible entity, as determined in Requirement R1, shall have dated evidence such as electronic or hard copies of its benchmark GMD Vulnerability Assessment meeting all of the requirements in Requirement R4. Each responsible entity, as determined in Requirement R1, shall also provide evidence, such as email records, web postings with an electronic notice of posting, or postal receipts showing recipient and date, that it has distributed its benchmark GMD Vulnerability Assessment: (i) to the responsible entity's Reliability Coordinator, adjacent Planning Coordinators, and adjacent Transmission Planners within 90 calendar days of completion, and (ii) to any functional entity that submits a written request and has a reliability-related need within 90 calendar days of receipt of such request or within 90 calendar days of completion of the benchmark GMD Vulnerability Assessment, whichever is later, as specified in Requirement R4. Each responsible entity, as determined in Requirement R1, shall also provide evidence, such as email notices or postal receipts showing recipient and date, that it has provided a documented response to comments received on its benchmark GMD Vulnerability Assessment within 90 calendar days of receipt of those comments in accordance with Requirement R4.
- R5.** Each responsible entity, as determined in Requirement R1, shall provide GIC flow information to be used for the benchmark thermal impact assessment of transformers specified in Requirement R6 to each Transmission Owner and Generator Owner that owns an applicable Bulk Electric System (BES) power transformer in the planning area. The GIC flow information shall include: *[Violation Risk Factor: Medium] [Time Horizon: Long-term Planning]*
- 5.1.** The maximum effective GIC value for the worst case geoelectric field orientation for the benchmark GMD event described in Attachment 1. This value shall be provided to the Transmission Owner or Generator Owner that owns each applicable BES power transformer in the planning area.

- 5.2.** The effective GIC time series, GIC(t), calculated using the benchmark GMD event described in Attachment 1 in response to a written request from the Transmission Owner or Generator Owner that owns an applicable BES power transformer in the planning area. GIC(t) shall be provided within 90 calendar days of receipt of the written request and after determination of the maximum effective GIC value in Part 5.1.
- M5.** Each responsible entity, as determined in Requirement R1, shall provide evidence, such as email records, web postings with an electronic notice of posting, or postal receipts showing recipient and date, that it has provided the maximum effective GIC values to the Transmission Owner and Generator Owner that owns each applicable BES power transformer in the planning area as specified in Requirement R5, Part 5.1. Each responsible entity, as determined in Requirement R1, shall also provide evidence, such as email records, web postings with an electronic notice of posting, or postal receipts showing recipient and date, that it has provided GIC(t) in response to a written request from the Transmission Owner or Generator Owner that owns an applicable BES power transformer in the planning area.
- R6.** Each Transmission Owner and Generator Owner shall conduct a benchmark thermal impact assessment for its solely and jointly owned applicable BES power transformers where the maximum effective GIC value provided in Requirement R5, Part 5.1, is 75 A per phase or greater. The benchmark thermal impact assessment shall: *[Violation Risk Factor: Medium] [Time Horizon: Long-term Planning]*
- 6.1.** Be based on the effective GIC flow information provided in Requirement R5;
- 6.2.** Document assumptions used in the analysis;
- 6.3.** Describe suggested actions and supporting analysis to mitigate the impact of GICs, if any; and
- 6.4.** Be performed and provided to the responsible entities, as determined in Requirement R1, within 24 calendar months of receiving GIC flow information specified in Requirement R5, Part 5.1.
- M6.** Each Transmission Owner and Generator Owner shall have evidence such as electronic or hard copies of its benchmark thermal impact assessment for all of its solely and jointly owned applicable BES power transformers where the maximum effective GIC value provided in Requirement R5, Part 5.1, is 75 A per phase or greater, and shall have evidence such as email records, web postings with an electronic notice of posting, or postal receipts showing recipient and date, that it has provided its thermal impact assessment to the responsible entities as specified in Requirement R6.

**Rationale for Requirement R7:** The proposed requirement addresses directives in Order No. 830 for establishing Corrective Action Plan (CAP) deadlines associated with GMD Vulnerability Assessments. In Order No. 830, FERC directed revisions to TPL-007 such that CAPs are developed within one year from the completion of GMD Vulnerability Assessments (P 101). Furthermore, FERC directed establishment of implementation deadlines after the completion of the CAP as follows (P 102):

- Two years for non-hardware mitigation; and
- Four years for hardware mitigation.

The objective of Part 7.4 is to provide awareness to potentially impacted entities when implementation of planned mitigation is not achievable within the deadlines established in Part 7.3. Examples of situations beyond the control of the of the responsible entity (see Section 7.4) include, but are not limited to:

- Delays resulting from regulatory/legal processes, such as permitting;
- Delays resulting from stakeholder processes required by tariff;
- Delays resulting from equipment lead times; or
- Delays resulting from the inability to acquire necessary Right-of-Way.

**R7.** Each responsible entity, as determined in Requirement R1, that concludes through the benchmark GMD Vulnerability Assessment conducted in Requirement R4 that their System does not meet the performance requirements for the steady state planning benchmark GMD event contained in Table 1, shall develop a Corrective Action Plan (CAP) addressing how the performance requirements will be met. The CAP shall:  
*[Violation Risk Factor: High] [Time Horizon: Long-term Planning]*

**7.1.** List System deficiencies and the associated actions needed to achieve required System performance. Examples of such actions include:

- Installation, modification, retirement, or removal of Transmission and generation Facilities and any associated equipment.
- Installation, modification, or removal of Protection Systems or Remedial Action Schemes.
- Use of Operating Procedures, specifying how long they will be needed as part of the CAP.
- Use of Demand-Side Management, new technologies, or other initiatives.

**7.2.** Be developed within one year of completion of the benchmark GMD Vulnerability Assessment.

**7.3.** Include a timetable, subject to revision by the responsible entity in Part 7.4, for implementing the selected actions from Part 7.1. The timetable shall:





functional entities referenced in the CAP within 90 calendar days of development or revision, and (ii) to any functional entity that submits a written request and has a reliability-related need within 90 calendar days of receipt of such request or within 90 calendar days of development or revision, whichever is later as specified in Requirement R7. Each responsible entity, as determined in Requirement R1, shall also provide evidence, such as email notices or postal receipts showing recipient and date, that it has provided a documented response to comments received on its CAP within 90 calendar days of receipt of those comments, in accordance with Requirement R7.

**Supplemental GMD Vulnerability Assessment(s)**

**Rationale for Requirements R8 – R10:** The proposed requirements address directives in Order No. 830 for revising the benchmark GMD event used in GMD Vulnerability Assessments (P 44, P 47-49). The requirements add a supplemental GMD Vulnerability Assessment based on the supplemental GMD event that accounts for localized peak geoelectric fields.

- R8.** Each responsible entity, as determined in Requirement R1, shall complete a supplemental GMD Vulnerability Assessment of the Near-Term Transmission Planning Horizon at least once every 60 calendar months. This supplemental GMD Vulnerability Assessment shall use a study or studies based on models identified in Requirement R2, document assumptions, and document summarized results of the steady state analysis. [*Violation Risk Factor: High*] [*Time Horizon: Long-term Planning*]
- 8.1.** The study or studies shall include the following conditions:
- 8.1.1.** System On-Peak Load for at least one year within the Near-Term Transmission Planning Horizon; and
  - 8.1.2.** System Off-Peak Load for at least one year within the Near-Term Transmission Planning Horizon.
- 8.2.** The study or studies shall be conducted based on the supplemental GMD event described in Attachment 1 to determine whether the System meets the performance requirements for the steady state planning supplemental GMD event contained in Table 1.
- 8.3.** If the analysis concludes there is Cascading caused by the supplemental GMD event described in Attachment 1, an evaluation of possible actions designed to reduce the likelihood or mitigate the consequences and adverse impacts of the event(s) shall be conducted.

- 8.4.** The supplemental GMD Vulnerability Assessment shall be provided: (i) to the responsible entity's Reliability Coordinator, adjacent Planning Coordinators, adjacent Transmission Planners within 90 calendar days of completion, and (ii) to any functional entity that submits a written request and has a reliability-related need within 90 calendar days of receipt of such request or within 90 calendar days of completion of the supplemental GMD Vulnerability Assessment, whichever is later.
- 8.4.1.** If a recipient of the supplemental GMD Vulnerability Assessment provides documented comments on the results, the responsible entity shall provide a documented response to that recipient within 90 calendar days of receipt of those comments.
- M8.** Each responsible entity, as determined in Requirement R1, shall have dated evidence such as electronic or hard copies of its supplemental GMD Vulnerability Assessment meeting all of the requirements in Requirement R8. Each responsible entity, as determined in Requirement R1, shall also provide evidence, such as email records, web postings with an electronic notice of posting, or postal receipts showing recipient and date, that it has distributed its supplemental GMD Vulnerability: (i) to the responsible entity's Reliability Coordinator, adjacent Planning Coordinators, adjacent Transmission Planners within 90 calendar days of completion, and (ii) to any functional entity that submits a written request and has a reliability-related need within 90 calendar days of receipt of such request or within 90 calendar days of completion of the supplemental GMD Vulnerability Assessment, whichever is later, as specified in Requirement R8. Each responsible entity, as determined in Requirement R1, shall also provide evidence, such as email notices or postal receipts showing recipient and date, that it has provided a documented response to comments received on its supplemental GMD Vulnerability Assessment within 90 calendar days of receipt of those comments in accordance with Requirement R8.
- R9.** Each responsible entity, as determined in Requirement R1, shall provide GIC flow information to be used for the supplemental thermal impact assessment of transformers specified in Requirement R10 to each Transmission Owner and Generator Owner that owns an applicable Bulk Electric System (BES) power transformer in the planning area. The GIC flow information shall include: *[Violation Risk Factor: Medium] [Time Horizon: Long-term Planning]*
- 9.1.** The maximum effective GIC value for the worst case geoelectric field orientation for the supplemental GMD event described in Attachment 1. This value shall be provided to the Transmission Owner or Generator Owner that owns each applicable BES power transformer in the planning area.

- 9.2.** The effective GIC time series, GIC(t), calculated using the supplemental GMD event described in Attachment 1 in response to a written request from the Transmission Owner or Generator Owner that owns an applicable BES power transformer in the planning area. GIC(t) shall be provided within 90 calendar days of receipt of the written request and after determination of the maximum effective GIC value in Part 9.1.
- M9.** Each responsible entity, as determined in Requirement R1, shall provide evidence, such as email records, web postings with an electronic notice of posting, or postal receipts showing recipient and date, that it has provided the maximum effective GIC values to the Transmission Owner and Generator Owner that owns each applicable BES power transformer in the planning area as specified in Requirement R9, Part 9.1. Each responsible entity, as determined in Requirement R1, shall also provide evidence, such as email records, web postings with an electronic notice of posting, or postal receipts showing recipient and date, that it has provided GIC(t) in response to a written request from the Transmission Owner or Generator Owner that owns an applicable BES power transformer in the planning area.
- R10.** Each Transmission Owner and Generator Owner shall conduct a supplemental thermal impact assessment for its solely and jointly owned applicable BES power transformers where the maximum effective GIC value provided in Requirement R9, Part 9.1, is 85 A per phase or greater. The supplemental thermal impact assessment shall: *[Violation Risk Factor: Medium] [Time Horizon: Long-term Planning]*
- 10.1.** Be based on the effective GIC flow information provided in Requirement R9;
- 10.2.** Document assumptions used in the analysis;
- 10.3.** Describe suggested actions and supporting analysis to mitigate the impact of GICs, if any; and
- 10.4.** Be performed and provided to the responsible entities, as determined in Requirement R1, within 24 calendar months of receiving GIC flow information specified in Requirement R9, Part 9.1.
- M10.** Each Transmission Owner and Generator Owner shall have evidence such as electronic or hard copies of its supplemental thermal impact assessment for all of its solely and jointly owned applicable BES power transformers where the maximum effective GIC value provided in Requirement R9, Part 9.1, is 85 A per phase or greater, and shall have evidence such as email records, web postings with an electronic notice of posting, or postal receipts showing recipient and date, that it has provided its supplemental thermal impact assessment to the responsible entities as specified in Requirement R10.

### GMD Measurement Data Processes

**Rationale for Requirements R11 and R12:** The proposed requirements address directives in Order No. 830 for requiring responsible entities to collect GIC monitoring and magnetometer data as necessary to enable model validation and situational awareness (P 88; P. 90-92). GMD measurement data refers to GIC monitor data and geomagnetic field data in Requirements R11 and R12, respectively. See the Guidelines and Technical Basis section of this standard for technical information.

The objective of Requirement R11 is for entities to obtain GIC data for the Planning Coordinator's planning area or other part of the system included in the Planning Coordinator's GIC System model to inform GMD Vulnerability Assessments. Technical considerations for GIC monitoring are contained in Chapter 9 of the *2012 Special Reliability Assessment Interim Report: Effects of Geomagnetic Disturbances on the Bulk-Power System* (NERC 2012 GMD Report). GIC monitoring is generally performed by Hall effect transducers that are attached to the neutral of the transformer and measure dc current flowing through the neutral.

The objective of Requirement R12 is for entities to obtain geomagnetic field data for the Planning Coordinator's planning area to inform GMD Vulnerability Assessments. Magnetometers provide geomagnetic field data by measuring changes in the earth's magnetic field. Sources of geomagnetic field data include:

- Observatories such as those operated by U.S. Geological Survey, Natural Resources Canada, research organizations, or university research facilities;
- Installed magnetometers; and
- Commercial or third-party sources of geomagnetic field data.

Geomagnetic field data for a Planning Coordinator's planning area is obtained from one or more of the above data sources located in the Planning Coordinator's planning area, or by obtaining a geomagnetic field data product for the Planning Coordinator's planning area from a government or research organization. The geomagnetic field data product does not need to be derived from a magnetometer or observatory within the Planning Coordinator's planning area.

**R11.** Each responsible entity, as determined in Requirement R1, shall implement a process to obtain GIC monitor data from at least one GIC monitor located in the Planning Coordinator's planning area or other part of the system included in the Planning Coordinator's GIC System model. *[Violation Risk Factor: Lower] [Time Horizon: Long-term Planning]*

**M11.** Each responsible entity, as determined in Requirement R1, shall have evidence such as electronic or hard copies of its GIC monitor location(s) and documentation of its process to obtain GIC monitor data in accordance with Requirement R11.

**R12.** Each responsible entity, as determined in Requirement R1, shall implement a process to obtain geomagnetic field data for its Planning Coordinator’s planning area.

*[Violation Risk Factor: Lower] [Time Horizon: Long-term Planning]*

**M12.** Each responsible entity, as determined in Requirement R1, shall have evidence such as electronic or hard copies of its process to obtain geomagnetic field data for its Planning Coordinator’s planning area in accordance with Requirement R12.

## C. Compliance

### 1. Compliance Monitoring Process

**1.1. Compliance Enforcement Authority:** “Compliance Enforcement Authority” means NERC or the Regional Entity, or any entity as otherwise designated by an Applicable Governmental Authority, in their respective roles of monitoring and/or enforcing compliance with mandatory and enforceable Reliability Standards in their respective jurisdictions.

**1.2. Evidence Retention:** The following evidence retention period(s) identify the period of time an entity is required to retain specific evidence to demonstrate compliance. For instances where the evidence retention period specified below is shorter than the time since the last audit, the Compliance Enforcement Authority may ask an entity to provide other evidence to show that it was compliant for the full-time period since the last audit.

The applicable entity shall keep data or evidence to show compliance as identified below unless directed by its Compliance Enforcement Authority to retain specific evidence for a longer period of time as part of an investigation.

- For Requirements R1, R2, R3, R5, R6, R9, and R10, each responsible entity shall retain documentation as evidence for five years.
- For Requirements R4 and R8, each responsible entity shall retain documentation of the current GMD Vulnerability Assessment and the preceding GMD Vulnerability Assessment.
- For Requirement R7, each responsible entity shall retain documentation as evidence for five years or until all actions in the Corrective Action Plan are completed, whichever is later.
- For Requirements R11 and R12, each responsible entity shall retain documentation as evidence for three years.

**1.3. Compliance Monitoring and Enforcement Program:** As defined in the NERC Rules of Procedure, “Compliance Monitoring and Enforcement Program” refers to the identification of the processes that will be used to evaluate data or information for the purpose of assessing performance or outcomes with the associated Reliability Standard.

<b>Table 1: Steady State Planning GMD Event</b>				
<b>Steady State:</b>				
<ul style="list-style-type: none"> <li>a. Voltage collapse, Cascading and uncontrolled islanding shall not occur.</li> <li>b. Generation loss is acceptable as a consequence of the steady state planning GMD events.</li> <li>c. Planned System adjustments such as Transmission configuration changes and re-dispatch of generation are allowed if such adjustments are executable within the time duration applicable to the Facility Ratings.</li> </ul>				
<b>Category</b>	<b>Initial Condition</b>	<b>Event</b>	<b>Interruption of Firm Transmission Service Allowed</b>	<b>Load Loss Allowed</b>
<b>Benchmark GMD Event - GMD Event with Outages</b>	1. System as may be postured in response to space weather information <sup>1</sup> , and then 2. GMD event <sup>2</sup>	Reactive Power compensation devices and other Transmission Facilities removed as a result of Protection System operation or Misoperation due to harmonics during the GMD event	Yes <sup>3</sup>	Yes <sup>3</sup>
<b>Supplemental GMD Event - GMD Event with Outages</b>	1. System as may be postured in response to space weather information <sup>1</sup> , and then 2. GMD event <sup>2</sup>	Reactive Power compensation devices and other Transmission Facilities removed as a result of Protection System operation or Misoperation due to harmonics during the GMD event	Yes	Yes
<b>Table 1: Steady State Performance Footnotes</b>				
<ul style="list-style-type: none"> <li>1. The System condition for GMD planning may include adjustments to posture the System that are executable in response to space weather information.</li> <li>2. The GMD conditions for the benchmark and supplemental planning events are described in Attachment 1.</li> <li>3. Load loss as a result of manual or automatic Load shedding (e.g., UVLS) and/or curtailment of Firm Transmission Service may be used to meet BES performance requirements during studied GMD conditions. The likelihood and magnitude of Load loss or curtailment of Firm Transmission Service should be minimized.</li> </ul>				

### Violation Severity Levels

R #	Violation Severity Levels			
	Lower VSL	Moderate VSL	High VSL	Severe VSL
R1.	N/A	N/A	N/A	The Planning Coordinator, in conjunction with its Transmission Planner(s), failed to determine and identify individual or joint responsibilities of the Planning Coordinator and Transmission Planner(s) in the Planning Coordinator’s planning area for maintaining models, performing the study or studies needed to complete benchmark and supplemental GMD Vulnerability Assessments, and implementing process(es) to obtain GMD measurement data as specified in this standard.

R #	Violation Severity Levels			
	Lower VSL	Moderate VSL	High VSL	Severe VSL
R2.	N/A	N/A	The responsible entity did not maintain either System models or GIC System models of the responsible entity’s planning area for performing the studies needed to complete benchmark and supplemental GMD Vulnerability Assessments.	The responsible entity did not maintain both System models and GIC System models of the responsible entity’s planning area for performing the studies needed to complete benchmark and supplemental GMD Vulnerability Assessments.
R3.	N/A	N/A	N/A	The responsible entity did not have criteria for acceptable System steady state voltage performance for its System during the GMD events described in Attachment 1 as required.



R #	Violation Severity Levels			
	Lower VSL	Moderate VSL	High VSL	Severe VSL
R4.	<p>The responsible entity completed a benchmark GMD Vulnerability Assessment, but it was more than 60 calendar months and less than or equal to 64 calendar months since the last benchmark GMD Vulnerability Assessment.</p>	<p>The responsible entity's completed benchmark GMD Vulnerability Assessment failed to satisfy one of the elements listed in Requirement R4, Parts 4.1 through 4.3;</p> <p>OR</p> <p>The responsible entity completed a benchmark GMD Vulnerability Assessment, but it was more than 64 calendar months and less than or equal to 68 calendar months since the last benchmark GMD Vulnerability Assessment.</p>	<p>The responsible entity's completed benchmark GMD Vulnerability Assessment failed to satisfy two of the elements listed in Requirement R4, Parts 4.1 through 4.3;</p> <p>OR</p> <p>The responsible entity completed a benchmark GMD Vulnerability Assessment, but it was more than 68 calendar months and less than or equal to 72 calendar months since the last benchmark GMD Vulnerability Assessment.</p>	<p>The responsible entity's completed benchmark GMD Vulnerability Assessment failed to satisfy three of the elements listed in Requirement R4, Parts 4.1 through 4.3;</p> <p>OR</p> <p>The responsible entity completed a benchmark GMD Vulnerability Assessment, but it was more than 72 calendar months since the last benchmark GMD Vulnerability Assessment;</p> <p>OR</p> <p>The responsible entity does not have a completed benchmark GMD Vulnerability Assessment.</p>

R #	Violation Severity Levels			
	Lower VSL	Moderate VSL	High VSL	Severe VSL
R5.	The responsible entity provided the effective GIC time series, GIC(t), in response to written request, but did so more than 90 calendar days and less than or equal to 100 calendar days after receipt of a written request.	The responsible entity provided the effective GIC time series, GIC(t), in response to written request, but did so more than 100 calendar days and less than or equal to 110 calendar days after receipt of a written request.	The responsible entity provided the effective GIC time series, GIC(t), in response to written request, but did so more than 110 calendar days after receipt of a written request.	The responsible entity did not provide the maximum effective GIC value to the Transmission Owner and Generator Owner that owns each applicable BES power transformer in the planning area; OR The responsible entity did not provide the effective GIC time series, GIC(t), upon written request.

<p><b>R6.</b></p>	<p>The responsible entity failed to conduct a benchmark thermal impact assessment for 5% or less or one of its solely owned and jointly owned applicable BES power transformers (whichever is greater) where the maximum effective GIC value provided in Requirement R5, Part 5.1, is 75 A or greater per phase; OR The responsible entity conducted a benchmark thermal impact assessment for its solely owned and jointly owned applicable BES power transformers where the maximum effective GIC value provided in Requirement R5, Part 5.1, is 75 A or greater per phase but did so more than 24 calendar months and less than or equal to 26 calendar months of receiving GIC flow information specified in Requirement R5, Part 5.1.</p>	<p>The responsible entity failed to conduct a benchmark thermal impact assessment for more than 5% up to (and including) 10% or two of its solely owned and jointly owned applicable BES power transformers (whichever is greater) where the maximum effective GIC value provided in Requirement R5, Part 5.1, is 75 A or greater per phase; OR The responsible entity conducted a benchmark thermal impact assessment for its solely owned and jointly owned applicable BES power transformers where the maximum effective GIC value provided in Requirement R5, Part 5.1, is 75 A or greater per phase but did so more than 26 calendar months and less than or equal to 28 calendar months of receiving GIC flow information specified in Requirement R5, Part 5.1;</p>	<p>The responsible entity failed to conduct a benchmark thermal impact assessment for more than 10% up to (and including) 15% or three of its solely owned and jointly owned applicable BES power transformers (whichever is greater) where the maximum effective GIC value provided in Requirement R5, Part 5.1, is 75 A or greater per phase; OR The responsible entity conducted a benchmark thermal impact assessment for its solely owned and jointly owned applicable BES power transformers where the maximum effective GIC value provided in Requirement R5, Part 5.1, is 75 A or greater per phase but did so more than 28 calendar months and less than or equal to 30 calendar months of receiving GIC flow information specified in Requirement R5, Part 5.1;</p>	<p>The responsible entity failed to conduct a benchmark thermal impact assessment for more than 15% or more than three of its solely owned and jointly owned applicable BES power transformers (whichever is greater) where the maximum effective GIC value provided in Requirement R5, Part 5.1, is 75 A or greater per phase; OR The responsible entity conducted a benchmark thermal impact assessment for its solely owned and jointly owned applicable BES power transformers where the maximum effective GIC value provided in Requirement R5, Part 5.1, is 75 A or greater per phase but did so more than 30 calendar months of receiving GIC flow information specified in Requirement R5, Part 5.1; OR</p>
-------------------	--	--	---	---

R #	Violation Severity Levels			
	Lower VSL	Moderate VSL	High VSL	Severe VSL
		OR The responsible entity failed to include one of the required elements as listed in Requirement R6, Parts 6.1 through 6.3.	OR The responsible entity failed to include two of the required elements as listed in Requirement R6, Parts 6.1 through 6.3.	The responsible entity failed to include three of the required elements as listed in Requirement R6, Parts 6.1 through 6.3.
<b>R7.</b>	The responsible entity's Corrective Action Plan failed to comply with one of the elements in Requirement R7, Parts 7.1 through 7.5.	The responsible entity's Corrective Action Plan failed to comply with two of the elements in Requirement R7, Parts 7.1 through 7.5.	The responsible entity's Corrective Action Plan failed to comply with three of the elements in Requirement R7, Parts 7.1 through 7.5.	The responsible entity's Corrective Action Plan failed to comply with four or more of the elements in Requirement R7, Parts 7.1 through 7.5; OR The responsible entity did not have a Corrective Action Plan as required by Requirement R7.

R #	Violation Severity Levels			
	Lower VSL	Moderate VSL	High VSL	Severe VSL
R8.	<p>The responsible entity's completed supplemental GMD Vulnerability Assessment failed to satisfy one of elements listed in Requirement R8, Parts 8.1 through 8.4;</p> <p>OR</p> <p>The responsible entity completed a supplemental GMD Vulnerability Assessment, but it was more than 60 calendar months and less than or equal to 64 calendar months since the last supplemental GMD Vulnerability Assessment.</p>	<p>The responsible entity's completed supplemental GMD Vulnerability Assessment failed to satisfy two of elements listed in Requirement R8, Parts 8.1 through 8.4;</p> <p>OR</p> <p>The responsible entity completed a supplemental GMD Vulnerability Assessment, but it was more than 64 calendar months and less than or equal to 68 calendar months since the last supplemental GMD Vulnerability Assessment.</p>	<p>The responsible entity's completed supplemental GMD Vulnerability Assessment failed to satisfy three of the elements listed in Requirement R8, Parts 8.1 through 8.4;</p> <p>OR</p> <p>The responsible entity completed a supplemental GMD Vulnerability Assessment, but it was more than 68 calendar months and less than or equal to 72 calendar months since the last supplemental GMD Vulnerability Assessment.</p>	<p>The responsible entity's completed supplemental GMD Vulnerability Assessment failed to satisfy four of the elements listed in Requirement R8, Parts 8.1 through 8.4;</p> <p>OR</p> <p>The responsible entity completed a supplemental GMD Vulnerability Assessment, but it was more than 72 calendar months since the last supplemental GMD Vulnerability Assessment;</p> <p>OR</p> <p>The responsible entity does not have a completed supplemental GMD Vulnerability Assessment.</p>

R #	Violation Severity Levels			
	Lower VSL	Moderate VSL	High VSL	Severe VSL
R9.	The responsible entity provided the effective GIC time series, GIC(t), in response to written request, but did so more than 90 calendar days and less than or equal to 100 calendar days after receipt of a written request.	The responsible entity provided the effective GIC time series, GIC(t), in response to written request, but did so more than 100 calendar days and less than or equal to 110 calendar days after receipt of a written request.	The responsible entity provided the effective GIC time series, GIC(t), in response to written request, but did so more than 110 calendar days after receipt of a written request.	The responsible entity did not provide the maximum effective GIC value to the Transmission Owner and Generator Owner that owns each applicable BES power transformer in the planning area; OR The responsible entity did not provide the effective GIC time series, GIC(t), upon written request.

<p><b>R10.</b></p>	<p>The responsible entity failed to conduct a supplemental thermal impact assessment for 5% or less or one of its solely owned and jointly owned applicable BES power transformers (whichever is greater) where the maximum effective GIC value provided in Requirement R9, Part 9.1, is 85 A or greater per phase; OR The responsible entity conducted a supplemental thermal impact assessment for its solely owned and jointly owned applicable BES power transformers where the maximum effective GIC value provided in Requirement R9, Part 9.1, is 85 A or greater per phase but did so more than 24 calendar months and less than or equal to 26 calendar months of receiving GIC flow information specified in Requirement R9, Part 9.1.</p>	<p>The responsible entity failed to conduct a supplemental thermal impact assessment for more than 5% up to (and including) 10% or two of its solely owned and jointly owned applicable BES power transformers (whichever is greater) where the maximum effective GIC value provided in Requirement R9, Part 9.1, is 85 A or greater per phase; OR The responsible entity conducted a supplemental thermal impact assessment for its solely owned and jointly owned applicable BES power transformers where the maximum effective GIC value provided in Requirement R9, Part 9.1, is 85 A or greater per phase but did so more than 26 calendar months and less than or equal to 28 calendar months of receiving GIC flow information specified in Requirement R9, Part 9.1</p>	<p>The responsible entity failed to conduct a supplemental thermal impact assessment for more than 10% up to (and including) 15% or three of its solely owned and jointly owned applicable BES power transformers (whichever is greater) where the maximum effective GIC value provided in Requirement R9, Part 9.1, is 85 A or greater per phase; OR The responsible entity conducted a supplemental thermal impact assessment for its solely owned and jointly owned applicable BES power transformers where the maximum effective GIC value provided in Requirement R9, Part 9.1, is 85 A or greater per phase but did so more than 28 calendar months and less than or equal to 30 calendar months of receiving GIC flow information specified in Requirement R9, Part 9.1;</p>	<p>The responsible entity failed to conduct a supplemental thermal impact assessment for more than 15% or more than three of its solely owned and jointly owned applicable BES power transformers (whichever is greater) where the maximum effective GIC value provided in Requirement R9, Part 9.1, is 85 A or greater per phase; OR The responsible entity conducted a supplemental thermal impact assessment for its solely owned and jointly owned applicable BES power transformers where the maximum effective GIC value provided in Requirement R9, Part 9.1, is 85 A or greater per phase but did so more than 30 calendar months of receiving GIC flow information specified in Requirement R9, Part 9.1; OR</p>
--------------------	--	---	---	---

R #	Violation Severity Levels			
	Lower VSL	Moderate VSL	High VSL	Severe VSL
		OR The responsible entity failed to include one of the required elements as listed in Requirement R10, Parts 10.1 through 10.3.	OR The responsible entity failed to include two of the required elements as listed in Requirement R10, Parts 10.1 through 10.3.	The responsible entity failed to include three of the required elements as listed in Requirement R10, Parts 10.1 through 10.3.
<b>R11.</b>	N/A	N/A	N/A	The responsible entity did not implement a process to obtain GIC monitor data from at least one GIC monitor located in the Planning Coordinator’s planning area or other part of the system included in the Planning Coordinator’s GIC System Model.
<b>R12.</b>	N/A	N/A	N/A	The responsible entity did not implement a process to obtain geomagnetic field data for its Planning Coordinator’s planning area.

**D. Regional Variances**

None.

**E. Associated Documents**

Attachment 1



## Version History

Version	Date	Action	Change Tracking
1	December 17, 2014	Adopted by the NERC Board of Trustees	New
2	TBD	Revised to respond to directives in FERC Order No. 830.	Revised

## Attachment 1

### Calculating Geoelectric Fields for the Benchmark and Supplemental GMD Events

The benchmark GMD event<sup>1</sup> defines the geoelectric field values used to compute GIC flows that are needed to conduct a benchmark GMD Vulnerability Assessment. It is composed of the following elements: (1) a reference peak geoelectric field amplitude of 8 V/km derived from statistical analysis of historical magnetometer data; (2) scaling factors to account for local geomagnetic latitude; (3) scaling factors to account for local earth conductivity; and (4) a reference geomagnetic field time series or waveform to facilitate time-domain analysis of GMD impact on equipment.

The supplemental GMD event is composed of similar elements as described above, except (1) the reference peak geoelectric field amplitude is 12 V/km over a localized area; and (2) the geomagnetic field time series or waveform includes a local enhancement in the waveform.<sup>2</sup>

The regional geoelectric field peak amplitude used in GMD Vulnerability Assessment,  $E_{peak}$ , can be obtained from the reference geoelectric field value of 8 V/km for the benchmark GMD event (1) or 12 V/km for the supplemental GMD event (2) using the following relationships:

$$E_{peak} = 8 \times \alpha \times \beta_b \text{ (V/km)} \quad (1)$$

$$E_{peak} = 12 \times \alpha \times \beta_s \text{ (V/km)} \quad (2)$$

where,  $\alpha$  is the scaling factor to account for local geomagnetic latitude, and  $\beta$  is a scaling factor to account for the local earth conductivity structure. Subscripts  $b$  and  $s$  for the  $\beta$  scaling factor denote association with the benchmark or supplemental GMD events, respectively.

### Scaling the Geomagnetic Field

The benchmark and supplemental GMD events are defined for geomagnetic latitude of 60° and must be scaled to account for regional differences based on geomagnetic latitude. Table 2 provides a scaling factor correlating peak geoelectric field to geomagnetic latitude. Alternatively, the scaling factor  $\alpha$  is computed with the empirical expression:

$$\alpha = 0.001 \times e^{(0.115 \times L)} \quad (3)$$

where,  $L$  is the geomagnetic latitude in degrees and  $0.1 \leq \alpha \leq 1$ .

<sup>1</sup> The Benchmark Geomagnetic Disturbance Event Description, May 2016 is available on the Related Information webpage for TPL-007-1: [http://www.nerc.com/pa/Stand/TPL0071RD/Benchmark\\_clean\\_May12\\_complete.pdf](http://www.nerc.com/pa/Stand/TPL0071RD/Benchmark_clean_May12_complete.pdf).

<sup>2</sup> The extent of local enhancements is on the order of 100 km in North-South (latitude) direction but longer in East-West (longitude) direction. The local enhancement in the geomagnetic field occurs over the time period of 2-5 minutes. Additional information is available in the Supplemental Geomagnetic Disturbance Event Description, October 2017 white paper on the Project 2013-03 Geomagnetic Disturbance Mitigation project webpage: <http://www.nerc.com/pa/Stand/Pages/Project-2013-03-Geomagnetic-Disturbance-Mitigation.aspx>.

For large planning areas that cover more than one scaling factor from Table 2, the GMD Vulnerability Assessment should be based on a peak geoelectric field that is:

- calculated by using the most conservative (largest) value for  $\alpha$ ; or
- calculated assuming a non-uniform or piecewise uniform geomagnetic field.

<b>Table 2: Geomagnetic Field Scaling Factors for the Benchmark and Supplemental GMD Events</b>	
<b>Geomagnetic Latitude (Degrees)</b>	<b>Scaling Factor1 (<math>\alpha</math>)</b>
≤ 40	0.10
45	0.2
50	0.3
54	0.5
56	0.6
57	0.7
58	0.8
59	0.9
≥ 60	1.0

### Scaling the Geoelectric Field

The benchmark GMD event is defined for the reference Quebec earth model described in Table 4. The peak geoelectric field,  $E_{peak}$ , used in a GMD Vulnerability Assessment may be obtained by either:

- Calculating the geoelectric field for the ground conductivity in the planning area and the reference geomagnetic field time series scaled according to geomagnetic latitude, using a procedure such as the plane wave method described in the NERC GMD Task Force GIC Application Guide;<sup>3</sup> or
- Using the earth conductivity scaling factor  $\beta$  from Table 3 that correlates to the ground conductivity map in Figure 1 or Figure 2. Along with the scaling factor  $\alpha$  from equation (3) or Table 2,  $\beta$  is applied to the reference geoelectric field using equation (1 or 2, as applicable) to obtain the regional geoelectric field peak amplitude  $E_{peak}$  to be used in GMD Vulnerability Assessments. When a ground conductivity model is not available, the planning entity should use the largest  $\beta$  factor of adjacent physiographic regions or a technically justified value.

<sup>3</sup> Available at the NERC GMD Task Force project webpage: [http://www.nerc.com/comm/PC/Pages/Geomagnetic-Disturbance-Task-Force-\(GMDTF\)-2013.aspx](http://www.nerc.com/comm/PC/Pages/Geomagnetic-Disturbance-Task-Force-(GMDTF)-2013.aspx).

The earth models used to calculate Table 3 for the United States were obtained from publicly available information published on the U. S. Geological Survey website.<sup>4</sup> The models used to calculate Table 3 for Canada were obtained from Natural Resources Canada (NRCan) and reflect the average structure for large regions. A planner can also use specific earth model(s) with documented justification and the reference geomagnetic field time series to calculate the  $\beta$  factor(s) as follows:

$$\beta_b = E/8 \text{ for the benchmark GMD event} \quad (4)$$

$$\beta_s = E/12 \text{ for the supplemental GMD} \quad (5)$$

where,  $E$  is the absolute value of peak geoelectric in V/km obtained from the technically justified earth model and the reference geomagnetic field time series.

For large planning areas that span more than one  $\beta$  scaling factor, the most conservative (largest) value for  $\beta$  may be used in determining the peak geoelectric field to obtain conservative results. Alternatively, a planner could perform analysis using a non-uniform or piecewise uniform geoelectric field.

### **Applying the Localized Peak Geoelectric Field in the Supplemental GMD Event**

The peak geoelectric field of the supplemental GMD event occurs in a localized area.<sup>5</sup> Planners have flexibility to determine how to apply the localized peak geoelectric field over the planning area in performing GIC calculations. Examples of approaches are:

- Apply the peak geoelectric field (12 V/km scaled to the planning area) over the entire planning area;
- Apply a spatially limited (12 V/km scaled to the planning area) peak geoelectric field (e.g., 100 km in North-South latitude direction and 500 km in East-West longitude direction) over a portion(s) of the system, and apply the benchmark GMD event over the rest of the system; or
- Other methods to adjust the benchmark GMD event analysis to account for the localized geoelectric field enhancement of the supplemental GMD event.

---

<sup>4</sup> Available at <http://geomag.usgs.gov/conductivity/>.

<sup>5</sup> See the Supplemental Geomagnetic Disturbance Description white paper located on the Project 2013-03 Geomagnetic Disturbance Mitigation project webpage: <http://www.nerc.com/pa/Stand/Pages/Project-2013-03-Geomagnetic-Disturbance-Mitigation.aspx>.

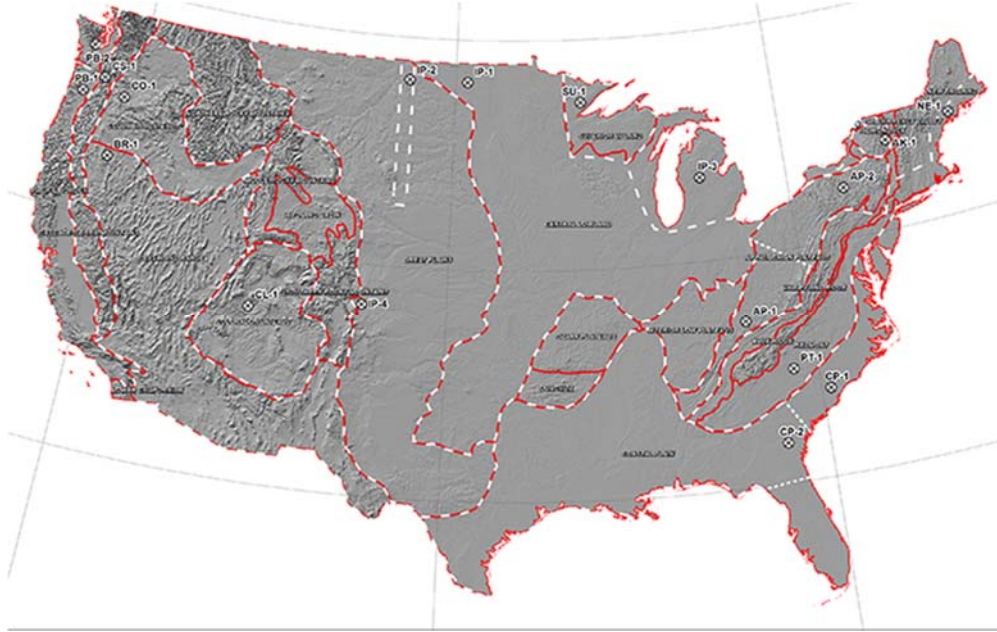


Figure 1: Physiographic Regions of the Continental United States<sup>6</sup>



Figure 2: Physiographic Regions of Canada

<sup>6</sup> Additional map detail is available at the U.S. Geological Survey: <http://geomag.usgs.gov/>.

<b>Table 3: Geoelectric Field Scaling Factors</b>		
<b>Earth model</b>	<b>Scaling Factor Benchmark Event (<math>\beta_b</math>)</b>	<b>Scaling Factor Supplemental Event (<math>\beta_s</math>)</b>
AK1A	0.56	0.51
AK1B	0.56	0.51
AP1	0.33	0.30
AP2	0.82	0.78
BR1	0.22	0.22
CL1	0.76	0.73
CO1	0.27	0.25
CP1	0.81	0.77
CP2	0.95	0.86
FL1	0.76	0.73
CS1	0.41	0.37
IP1	0.94	0.90
IP2	0.28	0.25
IP3	0.93	0.90
IP4	0.41	0.35
NE1	0.81	0.77
PB1	0.62	0.55
PB2	0.46	0.39
PT1	1.17	1.19
SL1	0.53	0.49
SU1	0.93	0.90
BOU	0.28	0.24
FBK	0.56	0.56
PRU	0.21	0.22
BC	0.67	0.62
PRAIRIES	0.96	0.88
SHIELD	1.0	1.0
ATLANTIC	0.79	0.76

**Rationale:** Scaling factors in Table 3 are dependent upon the frequency content of the reference storm. Consequently, the benchmark GMD event and the supplemental GMD event may produce different scaling factors for a given earth model.

The scaling factor associated with the benchmark GMD event for the Florida earth model (FL1) has been updated based on the earth model published on the USGS public website.

<b>Table 4: Reference Earth Model (Quebec)</b>	
<b>Layer Thickness (km)</b>	<b>Resistivity (<math>\Omega</math>-m)</b>
15	20,000
10	200
125	1,000
200	100
$\infty$	3

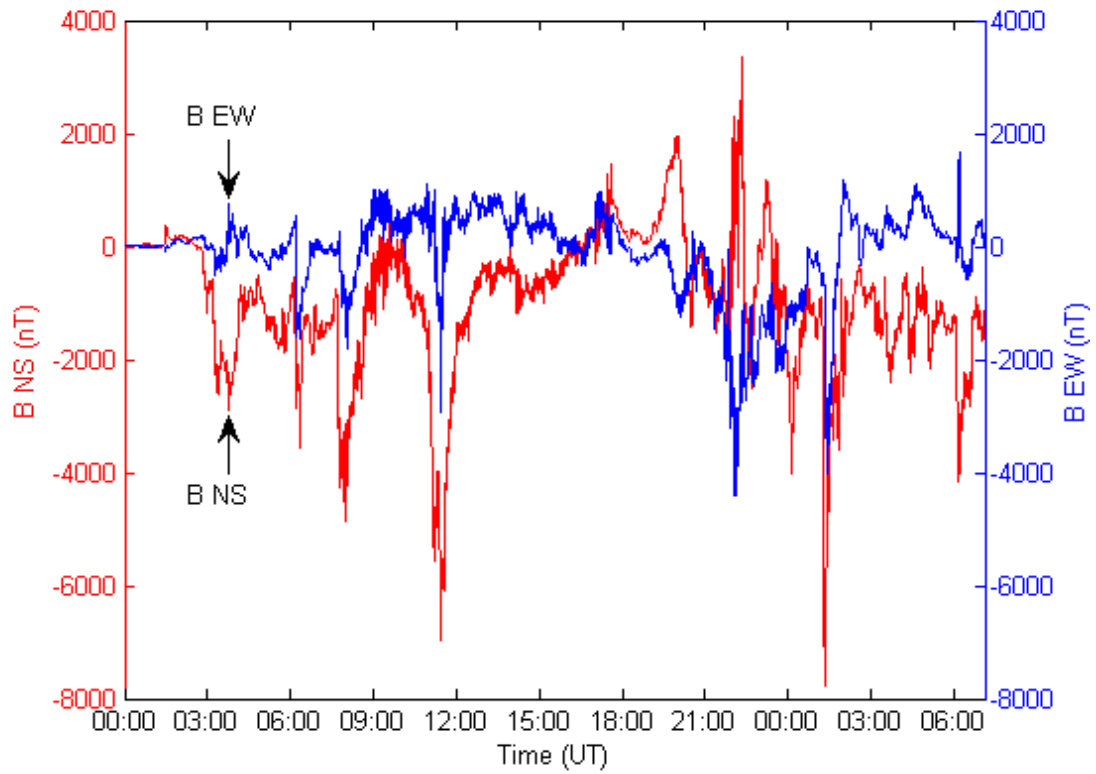
**Reference Geomagnetic Field Time Series or Waveform for the Benchmark GMD Event<sup>7</sup>**

The geomagnetic field measurement record of the March 13-14 1989 GMD event, measured at the NRCan Ottawa geomagnetic observatory, is the basis for the reference geomagnetic field waveform to be used to calculate the GIC time series, GIC(t), required for transformer thermal impact assessment.

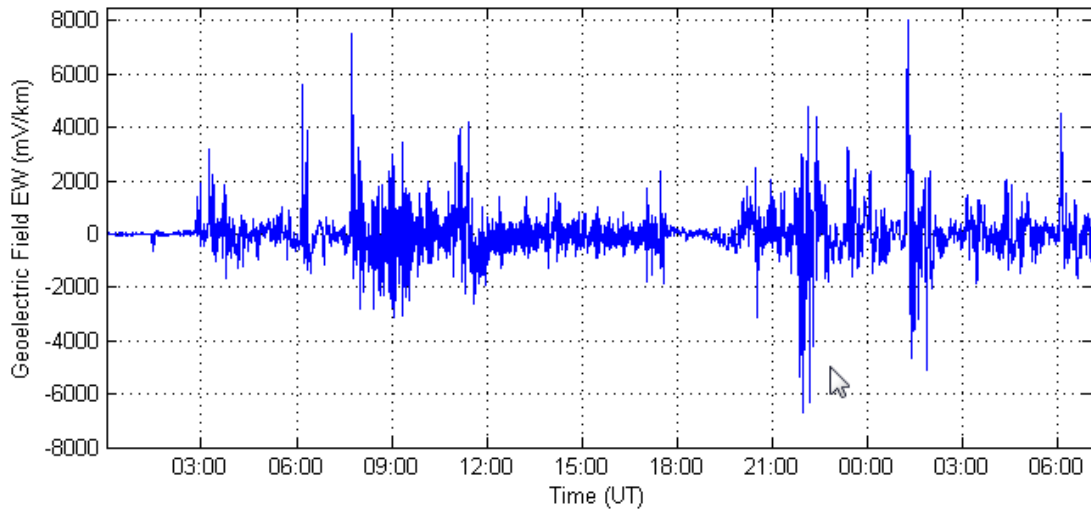
The geomagnetic latitude of the Ottawa geomagnetic observatory is 55°; therefore, the amplitudes of the geomagnetic field measurement data were scaled up to the 60° reference geomagnetic latitude (see Figure 3) such that the resulting peak geoelectric field amplitude computed using the reference earth model was 8 V/km (see Figures 4 and 5). The sampling rate for the geomagnetic field waveform is 10 seconds.<sup>8</sup> To use this geoelectric field time series when a different earth model is applicable, it should be scaled with the appropriate benchmark conductivity scaling factor  $\beta_b$ .

<sup>7</sup> Refer to the Benchmark Geomagnetic Disturbance Event Description white paper for details on the determination of the reference geomagnetic field waveform: <http://www.nerc.com/pa/stand/Pages/TPL0071RI.aspx>.

<sup>8</sup> The data file of the benchmark geomagnetic field waveform is available on the Related Information webpage for TPL-007-1: <http://www.nerc.com/pa/stand/Pages/TPL0071RI.aspx>.

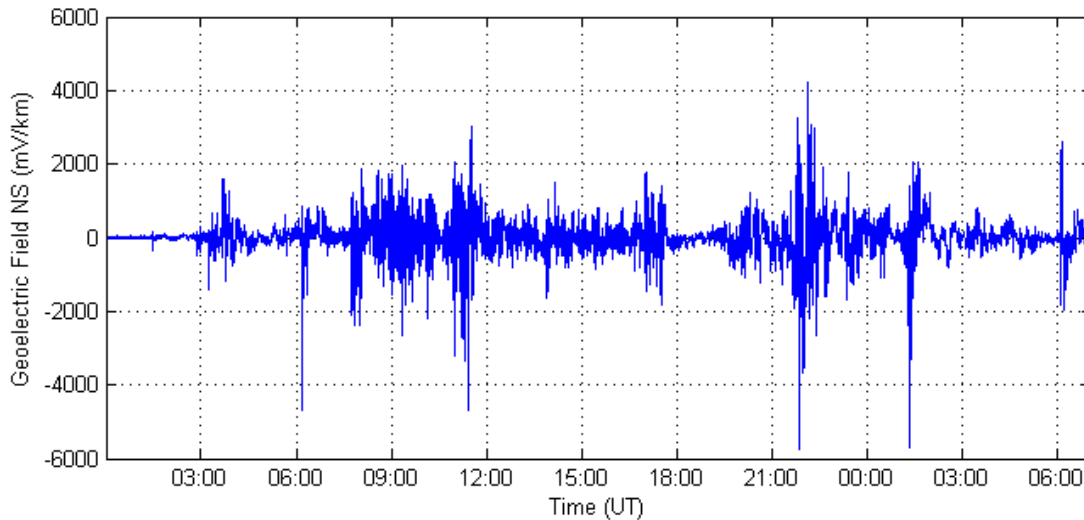


**Figure 3: Benchmark Geomagnetic Field Waveform**  
**Red  $B_n$  (Northward), Blue  $B_e$  (Eastward)**



**Figure 4: Benchmark Goelectric Field Waveform**  
 **$E_E$  (Eastward)**





**Figure 5: Benchmark Geoelectric Field Waveform  
 $E_N$  (Northward)**

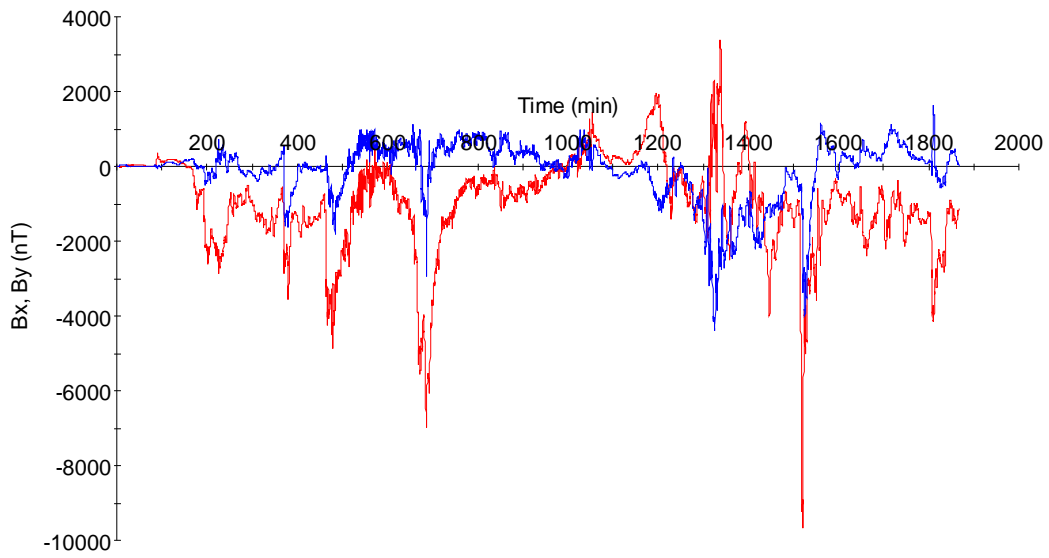
### Reference Geomagnetic Field Time Series or Waveform for the Supplemental GMD Event<sup>9</sup>

The geomagnetic field measurement record of the March 13-14, 1989 GMD event, measured at the NRCan Ottawa geomagnetic observatory, is the basis for the reference geomagnetic field waveform to be used to calculate the GIC time series,  $GIC(t)$ , required for transformer thermal impact assessment for the supplemental GMD event. The supplemental GMD event waveform differs from the benchmark GMD event waveform in that the supplemental GMD event waveform has a local enhancement.

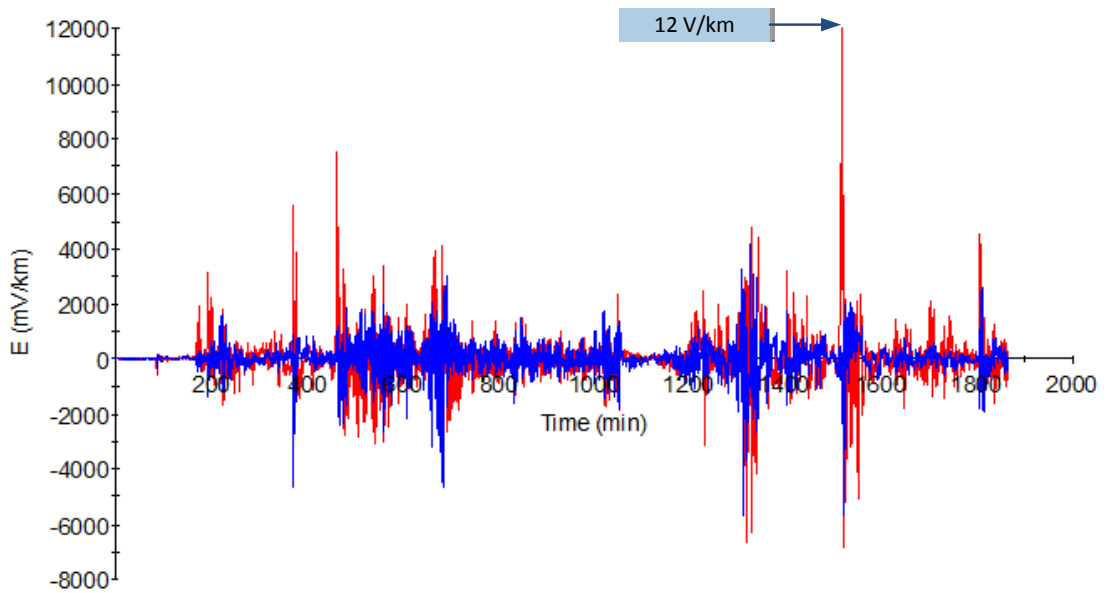
The geomagnetic latitude of the Ottawa geomagnetic observatory is  $55^\circ$ ; therefore, the amplitudes of the geomagnetic field measurement data were scaled up to the  $60^\circ$  reference geomagnetic latitude (see Figure 6) such that the resulting peak geoelectric field amplitude computed using the reference earth model was 12 V/km (see Figure 7). The sampling rate for the geomagnetic field waveform is 10 seconds.<sup>10</sup> To use this geoelectric field time series when a different earth model is applicable, it should be scaled with the appropriate supplemental conductivity scaling factor  $\beta_s$ .

<sup>9</sup> Refer to the Supplemental Geomagnetic Disturbance Event Description white paper for details on the determination of the reference geomagnetic field waveform: <http://www.nerc.com/pa/Stand/Pages/Project-2013-03-Geomagnetic-Disturbance-Mitigation.aspx>.

<sup>10</sup> The data file of the benchmark geomagnetic field waveform is available on the NERC GMD Task Force project webpage: [http://www.nerc.com/comm/PC/Pages/Geomagnetic-Disturbance-Task-Force-\(GMDTF\)-2013.aspx](http://www.nerc.com/comm/PC/Pages/Geomagnetic-Disturbance-Task-Force-(GMDTF)-2013.aspx).



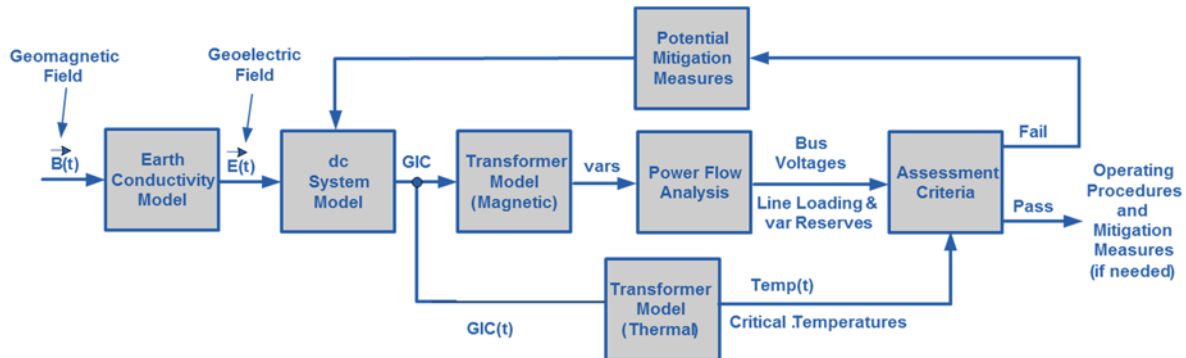
**Figure 6: Supplemental Geomagnetic Field Waveform  
Red  $B_N$  (Northward), Blue  $B_E$  (Eastward)**



**Figure 7: Supplemental Goelectric Field Waveform  
Blue  $E_N$  (Northward), Red  $E_E$  (Eastward)**

## Guidelines and Technical Basis

The diagram below provides an overall view of the GMD Vulnerability Assessment process:



The requirements in this standard cover various aspects of the GMD Vulnerability Assessment process.

### Benchmark GMD Event (Attachment 1)

The benchmark GMD event defines the geoelectric field values used to compute GIC flows that are needed to conduct a benchmark GMD Vulnerability Assessment. The *Benchmark Geomagnetic Disturbance Event Description*, May 2016<sup>11</sup> white paper includes the event description, analysis, and example calculations.

### Supplemental GMD Event (Attachment 1)

The supplemental GMD event defines the geoelectric field values used to compute GIC flows that are needed to conduct a supplemental GMD Vulnerability Assessment. The *Supplemental Geomagnetic Disturbance Event Description*, October 2017<sup>12</sup> white paper includes the event description and analysis.

### Requirement R2

A GMD Vulnerability Assessment requires a GIC System model, which is a dc representation of the System, to calculate GIC flow. In a GMD Vulnerability Assessment, GIC simulations are used to determine transformer Reactive Power absorption and transformer thermal response. Details for developing the GIC System model are provided in the NERC GMD Task Force guide: *Application Guide for Computing Geomagnetically-Induced Current in the Bulk Power System*, December 2013.<sup>13</sup>

Underground pipe-type cables present a special modeling situation in that the steel pipe that encloses the power conductors significantly reduces the geoelectric field induced into the conductors themselves, while they remain a path for GIC. Solid dielectric cables that are not enclosed by a steel pipe will not experience a reduction in the induced geoelectric field. A

<sup>11</sup> <http://www.nerc.com/pa/stand/Pages/TPL0071RI.aspx>.

<sup>12</sup> <http://www.nerc.com/pa/Stand/Pages/Project-2013-03-Geomagnetic-Disturbance-Mitigation.aspx>.

<sup>13</sup> [http://www.nerc.com/comm/PC/Geomagnetic%20Disturbance%20Task%20Force%20GMDTF%202013/GIC%20Application%20Guide%202013\\_approved.pdf](http://www.nerc.com/comm/PC/Geomagnetic%20Disturbance%20Task%20Force%20GMDTF%202013/GIC%20Application%20Guide%202013_approved.pdf).

planning entity should account for special modeling situations in the GIC system model, if applicable.

#### **Requirement R4**

The *Geomagnetic Disturbance Planning Guide*,<sup>14</sup> December 2013 developed by the NERC GMD Task Force provides technical information on GMD-specific considerations for planning studies.

#### **Requirement R5**

The benchmark thermal impact assessment of transformers specified in Requirement R6 is based on GIC information for the benchmark GMD Event. This GIC information is determined by the planning entity through simulation of the GIC System model and must be provided to the entity responsible for conducting the thermal impact assessment. GIC information should be provided in accordance with Requirement R5 each time the GMD Vulnerability Assessment is performed since, by definition, the GMD Vulnerability Assessment includes a documented evaluation of susceptibility to localized equipment damage due to GMD.

The maximum effective GIC value provided in Part 5.1 is used for the benchmark thermal impact assessment. Only those transformers that experience an effective GIC value of 75 A or greater per phase require evaluation in Requirement R6.

GIC(t) provided in Part 5.2 is used to convert the steady state GIC flows to time-series GIC data for the benchmark thermal impact assessment of transformers. This information may be needed by one or more of the methods for performing a benchmark thermal impact assessment. Additional information is in the following section and the *Transformer Thermal Impact Assessment White Paper*,<sup>15</sup> October 2017.

The peak GIC value of 75 Amps per phase has been shown through thermal modeling to be a conservative threshold below which the risk of exceeding known temperature limits established by technical organizations is low.

#### **Requirement R6**

The benchmark thermal impact assessment of a power transformer may be based on manufacturer-provided GIC capability curves, thermal response simulation, thermal impact screening, or other technically justified means. Approaches for conducting the assessment are presented in the *Transformer Thermal Impact Assessment White Paper ERO Enterprise-Endorsed Implementation Guidance*<sup>16</sup> for this requirement. This ERO-Endorsed document is posted on the NERC Compliance Guidance<sup>17</sup> webpage.

---

<sup>14</sup> [http://www.nerc.com/comm/PC/Geomagnetic%20Disturbance%20Task%20Force%20GMDTF%202013/GMD%20Planning%20Guide\\_approved.pdf](http://www.nerc.com/comm/PC/Geomagnetic%20Disturbance%20Task%20Force%20GMDTF%202013/GMD%20Planning%20Guide_approved.pdf).

<sup>15</sup> <http://www.nerc.com/pa/Stand/Pages/Project-2013-03-Geomagnetic-Disturbance-Mitigation.aspx>.

<sup>16</sup> [http://www.nerc.com/pa/comp/guidance/EROEndorsedImplementationGuidance/TPL-007-1\\_Transformer\\_Thermal\\_Impact\\_Assessment\\_White\\_Paper.pdf](http://www.nerc.com/pa/comp/guidance/EROEndorsedImplementationGuidance/TPL-007-1_Transformer_Thermal_Impact_Assessment_White_Paper.pdf).

<sup>17</sup> <http://www.nerc.com/pa/comp/guidance/Pages/default.aspx>.

Transformers are exempt from the benchmark thermal impact assessment requirement if the effective GIC value for the transformer is less than 75 A per phase, as determined by a GIC analysis of the System. Justification for this criterion is provided in the *Screening Criterion for Transformer Thermal Impact Assessment White Paper*,<sup>18</sup> October 2017. A documented design specification exceeding this value is also a justifiable threshold criterion that exempts a transformer from Requirement R6.

The benchmark threshold criteria and its associated transformer thermal impact must be evaluated on the basis of effective GIC. Refer to the white papers for additional information.

### **Requirement R7**

Technical considerations for GMD mitigation planning, including operating and equipment strategies, are available in Chapter 5 of the *Geomagnetic Disturbance Planning Guide*,<sup>19</sup> December 2013. Additional information is available in the *2012 Special Reliability Assessment Interim Report: Effects of Geomagnetic Disturbances on the Bulk-Power System*,<sup>20</sup> February 2012.

### **Requirement R8**

The *Geomagnetic Disturbance Planning Guide*,<sup>21</sup> December 2013 developed by the NERC GMD Task Force provides technical information on GMD-specific considerations for planning studies.

The supplemental GMD Vulnerability Assessment process is similar to the benchmark GMD Vulnerability Assessment process described under Requirement R4.

### **Requirement R9**

The supplemental thermal impact assessment specified of transformers in Requirement R10 is based on GIC information for the supplemental GMD Event. This GIC information is determined by the planning entity through simulation of the GIC System model and must be provided to the entity responsible for conducting the thermal impact assessment. GIC information should be provided in accordance with Requirement R9 each time the GMD Vulnerability Assessment is performed since, by definition, the GMD Vulnerability Assessment includes a documented evaluation of susceptibility to localized equipment damage due to GMD.

The maximum effective GIC value provided in Part 9.1 is used for the supplemental thermal impact assessment. Only those transformers that experience an effective GIC value of 85 A or greater per phase require evaluation in Requirement R10.

GIC(t) provided in Part 9.2 is used to convert the steady state GIC flows to time-series GIC data for the supplemental thermal impact assessment of transformers. This information may be

---

<sup>18</sup> <http://www.nerc.com/pa/Stand/Pages/Project-2013-03-Geomagnetic-Disturbance-Mitigation.aspx>.

<sup>19</sup> [http://www.nerc.com/comm/PC/Geomagnetic%20Disturbance%20Task%20Force%20GMDTF%202013/GMD%20Planning%20Guide\\_approved.pdf](http://www.nerc.com/comm/PC/Geomagnetic%20Disturbance%20Task%20Force%20GMDTF%202013/GMD%20Planning%20Guide_approved.pdf).

<sup>20</sup> <http://www.nerc.com/pa/RAPA/ra/Reliability%20Assessments%20DL/2012GMD.pdf>.

<sup>21</sup> [http://www.nerc.com/comm/PC/Geomagnetic%20Disturbance%20Task%20Force%20GMDTF%202013/GMD%20Planning%20Guide\\_approved.pdf](http://www.nerc.com/comm/PC/Geomagnetic%20Disturbance%20Task%20Force%20GMDTF%202013/GMD%20Planning%20Guide_approved.pdf).

needed by one or more of the methods for performing a supplemental thermal impact assessment. Additional information is in the following section.

The peak GIC value of 85 Amps per phase has been shown through thermal modeling to be a conservative threshold below which the risk of exceeding known temperature limits established by technical organizations is low.

### **Requirement R10**

The supplemental thermal impact assessment of a power transformer may be based on manufacturer-provided GIC capability curves, thermal response simulation, thermal impact screening, or other technically justified means. Approaches for conducting the assessment are presented in the *Transformer Thermal Impact Assessment White Paper ERO Enterprise-Endorsed Implementation Guidance*<sup>22</sup> discussed in the Requirement R6 section above. A later version of the *Transformer Thermal Impact Assessment White Paper*,<sup>23</sup> October 2017, has been developed to include updated information pertinent to the supplemental GMD event and supplemental thermal impact assessment.

Transformers are exempt from the supplemental thermal impact assessment requirement if the effective GIC value for the transformer is less than 85 A per phase, as determined by a GIC analysis of the System. Justification for this criterion is provided in the revised *Screening Criterion for Transformer Thermal Impact Assessment White Paper*,<sup>24</sup> October 2017. A documented design specification exceeding this value is also a justifiable threshold criterion that exempts a transformer from Requirement R10.

The supplemental threshold criteria and its associated transformer thermal impact must be evaluated on the basis of effective GIC. Refer to the white papers for additional information.

### **Requirement R11**

Technical considerations for GIC monitoring are contained in Chapter 6 of the *2012 Special Reliability Assessment Interim Report: Effects of Geomagnetic Disturbances on the Bulk-Power System*,<sup>25</sup> February 2012. GIC monitoring is generally performed by Hall effect transducers that are attached to the neutral of the wye-grounded transformer. Data from GIC monitors is useful for model validation and situational awareness.

Responsible entities consider the following in developing a process for obtaining GIC monitor data:

- **Monitor locations.** An entity's operating process may be constrained by location of existing GIC monitors. However, when planning for additional GIC monitoring installations consider that data from monitors located in areas found to have high GIC based on system

---

<sup>22</sup> [http://www.nerc.com/pa/comp/guidance/EROEndorsedImplementationGuidance/TPL-007-1\\_Transformer\\_Thermal\\_Impact\\_Assessment\\_White\\_Paper.pdf](http://www.nerc.com/pa/comp/guidance/EROEndorsedImplementationGuidance/TPL-007-1_Transformer_Thermal_Impact_Assessment_White_Paper.pdf).

<sup>23</sup> <http://www.nerc.com/pa/Stand/Pages/Project-2013-03-Geomagnetic-Disturbance-Mitigation.aspx>.

<sup>24</sup> <http://www.nerc.com/pa/Stand/Pages/Project-2013-03-Geomagnetic-Disturbance-Mitigation.aspx>.

<sup>25</sup> <http://www.nerc.com/pa/RAPA/ra/Reliability%20Assessments%20DL/2012GMD.pdf>.

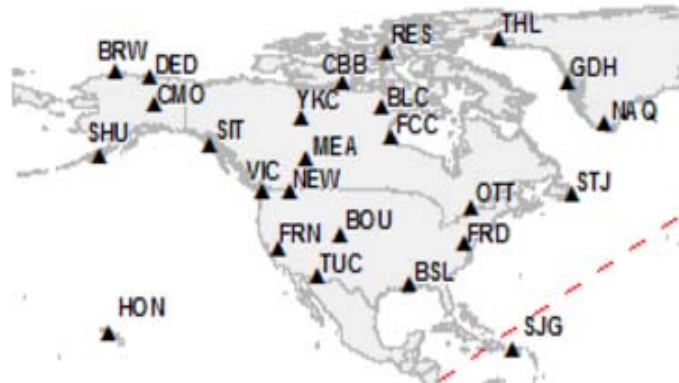
studies may provide more useful information for validation and situational awareness purposes. Conversely, data from GIC monitors that are located in the vicinity of transportation systems using direct current (e.g., subways or light rail) may be unreliable.

- **Monitor specifications.** Capabilities of Hall effect transducers, existing and planned, should be considered in the operating process. When planning new GIC monitor installations, consider monitor data range (e.g., -500 A through + 500 A) and ambient temperature ratings consistent with temperatures in the region in which the monitor will be installed.
- **Sampling Interval.** An entity's operating process may be constrained by capabilities of existing GIC monitors. However, when possible specify data sampling during periods of interest at a rate of 10 seconds or faster.
- **Collection Periods.** The process should specify when the entity expects GIC data to be collected. For example, collection could be required during periods where the Kp index is above a threshold, or when GIC values are above a threshold. Determining when to discontinue collecting GIC data should also be specified to maintain consistency in data collection.
- **Data format.** Specify time and value formats. For example, Greenwich Mean Time (GMT) (MM/DD/YYYY HH:MM:SS) and GIC Value (Ampere). Positive (+) and negative (-) signs indicate direction of GIC flow. Positive reference is flow from ground into transformer neutral. Time fields should indicate the sampled time rather than system or SCADA time if supported by the GIC monitor system.
- **Data retention.** The entity's process should specify data retention periods, for example 1 year. Data retention periods should be adequately long to support availability for the entity's model validation process and external reporting requirements, if any.
- **Additional information.** The entity's process should specify collection of other information necessary for making the data useful, for example monitor location and type of neutral connection (e.g., three-phase or single-phase).

### **Requirement R12**

Magnetometers measure changes in the earth's magnetic field. Entities should obtain data from the nearest accessible magnetometer. Sources of magnetometer data include:

- Observatories such as those operated by U.S. Geological Survey and Natural Resources Canada, see figure below for locations:<sup>26</sup>



- Research institutions and academic universities;
- Entities with installed magnetometers.

Entities that choose to install magnetometers should consider equipment specifications and data format protocols contained in the latest version of the *INTERMAGNET Technical Reference Manual*, Version 4.6, 2012.<sup>27</sup>

## Rationale

During development of TPL-007-1, text boxes were embedded within the standard to explain the rationale for various parts of the standard. The text from the rationale text boxes was moved to this section upon approval of TPL-007-1 by the NERC Board of Trustees. In developing TPL-007-2, the SDT has made changes to the sections below only when necessary for clarity. Changes are marked with brackets [ ].

### Rationale for Applicability:

Instrumentation transformers and station service transformers do not have significant impact on geomagnetically-induced current (GIC) flows; therefore, these transformers are not included in the applicability for this standard.

Terminal voltage describes line-to-line voltage.

### Rationale for R1:

In some areas, planning entities may determine that the most effective approach to conduct a GMD Vulnerability Assessment is through a regional planning organization. No requirement in the standard is intended to prohibit a collaborative approach where roles and responsibilities are determined by a planning organization made up of one or more Planning Coordinator(s).

---

<sup>26</sup> <http://www.intermagnet.org/index-eng.php>.

<sup>27</sup> [http://www.intermagnet.org/publications/intermag\\_4-6.pdf](http://www.intermagnet.org/publications/intermag_4-6.pdf).



**Rationale for R2:**

A GMD Vulnerability Assessment requires a GIC System model to calculate GIC flow which is used to determine transformer Reactive Power absorption and transformer thermal response. Guidance for developing the GIC System model is provided in the *Application Guide Computing Geomagnetically-Induced Current in the Bulk-Power System*,<sup>28</sup> December 2013, developed by the NERC GMD Task Force.

The System model specified in Requirement R2 is used in conducting steady state power flow analysis that accounts for the Reactive Power absorption of power transformer(s) due to GIC in the System.

The GIC System model includes all power transformer(s) with a high side, wye-grounded winding with terminal voltage greater than 200 kV. The model is used to calculate GIC flow in the network.

The projected System condition for GMD planning may include adjustments to the System that are executable in response to space weather information. These adjustments could include, for example, recalling or postponing maintenance outages.

The Violation Risk Factor (VRF) for Requirement R2 is changed from Medium to High. This change is for consistency with the VRF for approved standard TPL-001-4 Requirement R1, which is proposed for revision in the NERC filing dated August 29, 2014 (Docket No. RM12-1-000). NERC guidelines require consistency among Reliability Standards.

**Rationale for R3:**

Requirement R3 allows a responsible entity the flexibility to determine the System steady state voltage criteria for System steady state performance in Table 1. Steady state voltage limits are an example of System steady state performance criteria.

**Rationale for R4:**

The GMD Vulnerability Assessment includes steady state power flow analysis and the supporting study or studies using the models specified in Requirement R2 that account for the effects of GIC. Performance criteria are specified in Table 1.

At least one System On-Peak Load and at least one System Off-Peak Load must be examined in the analysis.

Distribution of GMD Vulnerability Assessment results provides a means for sharing relevant information with other entities responsible for planning reliability. Results of GIC studies may affect neighboring systems and should be taken into account by planners.

---

<sup>28</sup> [http://www.nerc.com/comm/PC/Geomagnetic%20Disturbance%20Task%20Force%20GMDTF%202013/GIC%20Application%20Guide%202013\\_approved.pdf](http://www.nerc.com/comm/PC/Geomagnetic%20Disturbance%20Task%20Force%20GMDTF%202013/GIC%20Application%20Guide%202013_approved.pdf).

The *Geomagnetic Disturbance Planning Guide*,<sup>29</sup> December 2013 developed by the NERC GMD Task Force provides technical information on GMD-specific considerations for planning studies. The provision of information in Requirement R4, Part 4.3, shall be subject to the legal and regulatory obligations for the disclosure of confidential and/or sensitive information.

**Rationale for R5:**

This GIC information is necessary for determining the thermal impact of GIC on transformers in the planning area and must be provided to entities responsible for performing the thermal impact assessment so that they can accurately perform the assessment. GIC information should be provided in accordance with Requirement R5 as part of the GMD Vulnerability Assessment process since, by definition, the GMD Vulnerability Assessment includes documented evaluation of susceptibility to localized equipment damage due to GMD.

The maximum effective GIC value provided in Part 5.1 is used for transformer thermal impact assessment.

GIC(t) provided in Part 5.2 can alternatively be used to convert the steady state GIC flows to time-series GIC data for transformer thermal impact assessment. This information may be needed by one or more of the methods for performing a thermal impact assessment. Additional guidance is available in the *Transformer Thermal Impact Assessment White Paper*,<sup>30</sup> October 2017.

A Transmission Owner or Generator Owner that desires GIC(t) may request it from the planning entity. The planning entity shall provide GIC(t) upon request once GIC has been calculated, but no later than 90 calendar days after receipt of a request from the owner and after completion of Requirement R5, Part 5.1.

The provision of information in Requirement R5 shall be subject to the legal and regulatory obligations for the disclosure of confidential and/or sensitive information.

**Rationale for R6:**

The transformer thermal impact screening criterion has been revised from 15 A per phase to 75 A per phase [for the benchmark GMD event]. Only those transformers that experience an effective GIC value of 75 A per phase or greater require evaluation in Requirement R6. The justification is provided in the *Screening Criterion for Transformer Thermal Impact Assessment White Paper*,<sup>31</sup> October 2017.

The thermal impact assessment may be based on manufacturer-provided GIC capability curves, thermal response simulation, thermal impact screening, or other technically justified means. The transformer thermal assessment will be repeated or reviewed using previous assessment results each time the planning entity performs a GMD Vulnerability Assessment and provides GIC

---

<sup>29</sup> [http://www.nerc.com/comm/PC/Geomagnetic%20Disturbance%20Task%20Force%20GMDTF%202013/GMD%20Planning%20Guide\\_approved.pdf](http://www.nerc.com/comm/PC/Geomagnetic%20Disturbance%20Task%20Force%20GMDTF%202013/GMD%20Planning%20Guide_approved.pdf).

<sup>30</sup> <http://www.nerc.com/pa/Stand/Pages/Project-2013-03-Geomagnetic-Disturbance-Mitigation.aspx>.

<sup>31</sup> <http://www.nerc.com/pa/Stand/Pages/Project-2013-03-Geomagnetic-Disturbance-Mitigation.aspx>.

information as specified in Requirement R5. Approaches for conducting the assessment are presented in the *Transformer Thermal Impact Assessment White Paper*,<sup>32</sup> October 2017.

Thermal impact assessments are provided to the planning entity, as determined in Requirement R1, so that identified issues can be included in the GMD Vulnerability Assessment (R4), and the Corrective Action Plan (R7) as necessary.

Thermal impact assessments of non-BES transformers are not required because those transformers do not have a wide-area effect on the reliability of the interconnected Transmission system.

The provision of information in Requirement R6, Part 6.4, shall be subject to the legal and regulatory obligations for the disclosure of confidential and/or sensitive information.

**Rationale for R7:**

Corrective Action Plans are defined in the NERC Glossary of Terms:

*A list of actions and an associated timetable for implementation to remedy a specific problem.*

Corrective Action Plans must, subject to the vulnerabilities identified in the assessments, contain strategies for protecting against the potential impact of the benchmark GMD event, based on factors such as the age, condition, technical specifications, system configuration, or location of specific equipment. Chapter 5 of the NERC GMD Task Force *Geomagnetic Disturbance Planning Guide*,<sup>33</sup> December 2013 provides a list of mitigating measures that may be appropriate to address an identified performance issue.

The provision of information in Requirement R7, Part 7.3 [Part 7.5 in TPL-007-2], shall be subject to the legal and regulatory obligations for the disclosure of confidential and/or sensitive information.

**Rationale for Table 3:**

Table 3 has been revised to use the same ground model designation, FL1, as is being used by USGS. The calculated scaling factor for FL1 is 0.74. [The scaling factor associated with the benchmark GMD event for the Florida earth model (FL1) has been updated to 0.76 in TPL-007-2 based on the earth model published on the USGS public website.]

---

<sup>32</sup> <http://www.nerc.com/pa/Stand/Pages/Project-2013-03-Geomagnetic-Disturbance-Mitigation.aspx>.

<sup>33</sup> [http://www.nerc.com/comm/PC/Geomagnetic%20Disturbance%20Task%20Force%20GMDTF%202013/GMD%20Planning%20Guide\\_approved.pdf](http://www.nerc.com/comm/PC/Geomagnetic%20Disturbance%20Task%20Force%20GMDTF%202013/GMD%20Planning%20Guide_approved.pdf).

## Standard Development Timeline

This section is maintained by the drafting team during the development of the standard and will be removed when the standard is adopted by the NERC Board of Trustees (Board).

### Description of Current Draft

Completed Actions	Date
Standards Committee approved Standard Authorization Request (SAR) for posting	December 14, 2016
SAR posted for comment	December 16, 2016 – January 20, 2017
<u>45-day formal comment period with initial ballot</u>	<u>June 28 – August 11, 2017</u>

Anticipated Actions	Date
<del>45-day formal comment period with ballot</del>	<del>June 2017</del>
<del>45-day formal comment period with additional ballot</del>	<del>September 2017</del>
10-day final ballot	<del>TBD</del> <u>October 2017</u>
Board adoption	<del>February 2018</del> <u>November 2017</u>

## **New or Modified Term(s) Used in NERC Reliability Standards**

This section includes all new or modified terms used in the proposed standard that will be included in the *Glossary of Terms Used in NERC Reliability Standards* upon applicable regulatory approval. Terms used in the proposed standard that are already defined and are not being modified can be found in the *Glossary of Terms Used in NERC Reliability Standards*. The new or revised terms listed below will be presented for approval with the proposed standard. Upon Board adoption, this section will be removed.

### **Term(s):**

None

Upon Board adoption, the rationale boxes will be moved to the Supplemental Material Section.

## A. Introduction

1. **Title:** Transmission System Planned Performance for Geomagnetic Disturbance Events
2. **Number:** TPL-007-2
3. **Purpose:** Establish requirements for Transmission system planned performance during geomagnetic disturbance (GMD) events.
4. **Applicability:**
  - 4.1. **Functional Entities:**
    - 4.1.1. Planning Coordinator with a planning area that includes a Facility or Facilities specified in 4.2;
    - 4.1.2. Transmission Planner with a planning area that includes a Facility or Facilities specified in 4.2;
    - 4.1.3. Transmission Owner who owns a Facility or Facilities specified in 4.2; and
    - 4.1.4. Generator Owner who owns a Facility or Facilities specified in 4.2.
  - 4.2. **Facilities:**
    - 4.2.1. Facilities that include power transformer(s) with a high side, wye-grounded winding with terminal voltage greater than 200 kV.
5. **Effective Date:** See Implementation Plan for TPL-007-~~1~~2.
6. **Background:** During a GMD event, geomagnetically-induced currents (GIC) may cause transformer hot-spot heating or damage, loss of Reactive Power sources, increased Reactive Power demand, and Misoperation(s), the combination of which may result in voltage collapse and blackout.

## B. Requirements and Measures

- R1. Each Planning Coordinator, in conjunction with its Transmission Planner(s), shall identify the individual and joint responsibilities of the Planning Coordinator and Transmission Planner(s) in the Planning Coordinator's planning area for maintaining models, performing the study or studies needed to complete benchmark and supplemental GMD Vulnerability Assessments, and implementing process(es) to obtain GMD measurement data as specified in this standard. [*Violation Risk Factor: Lower*] [*Time Horizon: Long-term Planning*]

- M1.** Each Planning Coordinator, in conjunction with its Transmission Planners, shall provide documentation on roles and responsibilities, such as meeting minutes, agreements, copies of procedures or protocols in effect between entities or between departments of a vertically integrated system, or email correspondence that identifies an agreement has been reached on individual and joint responsibilities for maintaining models, performing the study or studies needed to complete benchmark and supplemental GMD Vulnerability Assessments, and implementing process(es) to obtain GMD measurement data in accordance with Requirement R1.
- R2.** Each responsible entity, as determined in Requirement R1, shall maintain System models and GIC System models of the responsible entity’s planning area for performing the study or studies needed to complete benchmark and supplemental GMD Vulnerability Assessments. *[Violation Risk Factor: High] [Time Horizon: Long-term Planning]*
- M2.** Each responsible entity, as determined in Requirement R1, shall have evidence in either electronic or hard copy format that it is maintaining System models and GIC System models of the responsible entity’s planning area for performing the study or studies needed to complete benchmark and supplemental GMD Vulnerability Assessments.
- R3.** Each responsible entity, as determined in Requirement R1, shall have criteria for acceptable System steady state voltage performance for its System during the GMD events described in Attachment 1. *[Violation Risk Factor: Medium] [Time Horizon: Long-term Planning]*
- M3.** Each responsible entity, as determined in Requirement R1, shall have evidence, such as electronic or hard copies of the criteria for acceptable System steady state voltage performance for its System in accordance with Requirement R3.

**Benchmark GMD Vulnerability Assessment(s)**

- R4.** Each responsible entity, as determined in Requirement R1, shall complete a benchmark GMD Vulnerability Assessment of the Near-Term Transmission Planning Horizon at least once every 60 calendar months. This benchmark GMD Vulnerability Assessment shall use a study or studies based on models identified in Requirement R2, document assumptions, and document summarized results of the steady state analysis. *[Violation Risk Factor: High] [Time Horizon: Long-term Planning]*
- 4.1.** The study or studies shall include the following conditions:
- 4.1.1.** System On-Peak Load for at least one year within the Near-Term Transmission Planning Horizon; and
  - 4.1.2.** System Off-Peak Load for at least one year within the Near-Term Transmission Planning Horizon.

- 4.2.** The study or studies shall be conducted based on the benchmark GMD event described in Attachment 1 to determine whether the System meets the performance requirements for the steady state planning benchmark GMD event contained in Table 1.
- 4.3.** The benchmark GMD Vulnerability Assessment shall be provided: (i) to the responsible entity's Reliability Coordinator, adjacent Planning Coordinators, and adjacent Transmission Planners within 90 calendar days of completion, and (ii) to any functional entity that submits a written request and has a reliability-related need within 90 calendar days of receipt of such request or within 90 calendar days of completion of the benchmark GMD Vulnerability Assessment, whichever is later.
- 4.3.1.** If a recipient of the benchmark GMD Vulnerability Assessment provides documented comments on the results, the responsible entity shall provide a documented response to that recipient within 90 calendar days of receipt of those comments.
- M4.** Each responsible entity, as determined in Requirement R1, shall have dated evidence such as electronic or hard copies of its benchmark GMD Vulnerability Assessment meeting all of the requirements in Requirement R4. Each responsible entity, as determined in Requirement R1, shall also provide evidence, such as email records, web postings with an electronic notice of posting, or postal receipts showing recipient and date, that it has distributed its benchmark GMD Vulnerability Assessment: (i) to the responsible entity's Reliability Coordinator, adjacent Planning Coordinators, and adjacent Transmission Planners within 90 calendar days of completion, and (ii) to any functional entity that submits a written request and has a reliability-related need within 90 calendar days of receipt of such request or within 90 calendar days of completion of the benchmark GMD Vulnerability Assessment, whichever is later, as specified in Requirement R4. Each responsible entity, as determined in Requirement R1, shall also provide evidence, such as email notices or postal receipts showing recipient and date, that it has provided a documented response to comments received on its benchmark GMD Vulnerability Assessment within 90 calendar days of receipt of those comments in accordance with Requirement R4.
- R5.** Each responsible entity, as determined in Requirement R1, shall provide GIC flow information to be used for the benchmark thermal impact assessment of transformers specified in Requirement R6 to each Transmission Owner and Generator Owner that owns an applicable Bulk Electric System (BES) power transformer in the planning area. The GIC flow information shall include: *[Violation Risk Factor: Medium] [Time Horizon: Long-term Planning]*
- 5.1.** The maximum effective GIC value for the worst case geoelectric field orientation for the benchmark GMD event described in Attachment 1. This value shall be provided to the Transmission Owner or Generator Owner that owns each applicable BES power transformer in the planning area.



- 5.2.** The effective GIC time series, GIC(t), calculated using the benchmark GMD event described in Attachment 1 in response to a written request from the Transmission Owner or Generator Owner that owns an applicable BES power transformer in the planning area. GIC(t) shall be provided within 90 calendar days of receipt of the written request and after determination of the maximum effective GIC value in Part 5.1.
- M5.** Each responsible entity, as determined in Requirement R1, shall provide evidence, such as email records, web postings with an electronic notice of posting, or postal receipts showing recipient and date, that it has provided the maximum effective ~~benchmark GIC value~~values to the Transmission Owner and Generator Owner that owns each applicable BES power transformer in the planning area as specified in Requirement R5, Part 5.1. Each responsible entity, as determined in Requirement R1, shall also provide evidence, such as email records, web postings with an electronic notice of posting, or postal receipts showing recipient and date, that it has provided GIC(t) in response to a written request from the Transmission Owner or Generator Owner that owns an applicable BES power transformer in the planning area.
- R6.** Each Transmission Owner and Generator Owner shall conduct a benchmark thermal impact assessment for its solely and jointly owned applicable BES power transformers where the maximum effective GIC value provided in Requirement R5, Part 5.1, is 75 A per phase or greater. The benchmark thermal impact assessment shall: *[Violation Risk Factor: Medium] [Time Horizon: Long-term Planning]*
- 6.1.** Be based on the effective GIC flow information provided in Requirement R5;
- 6.2.** Document assumptions used in the analysis;
- 6.3.** Describe suggested actions and supporting analysis to mitigate the impact of GICs, if any; and
- 6.4.** Be performed and provided to the responsible entities, as determined in Requirement R1, within 24 calendar months of receiving GIC flow information specified in Requirement R5, Part 5.1.
- M6.** Each Transmission Owner and Generator Owner shall have evidence such as electronic or hard copies of its benchmark thermal impact assessment for all of its solely and jointly owned applicable BES power transformers where the maximum effective GIC value provided in Requirement R5, Part 5.1, is 75 A per phase or greater, and shall have evidence such as email records, web postings with an electronic notice of posting, or postal receipts showing recipient and date, that it has provided its thermal impact assessment to the responsible entities as specified in Requirement R6.

**Rationale for Requirement R7:** The proposed requirement addresses directives in Order No. 830 for establishing Corrective Action Plan (CAP) deadlines associated with GMD Vulnerability Assessments. In Order No. 830, FERC directed revisions to TPL-007 such that CAPs are developed within one year from the completion of GMD Vulnerability Assessments (P- 101). Furthermore, FERC directed establishment of implementation deadlines after the completion of the CAP as follows (P- 102):

- Two years for non-hardware mitigation; and
- Four years for hardware mitigation.

The objective of Part 7.4 is to provide awareness to potentially impacted entities when implementation of planned mitigation is not achievable within the deadlines established in Part 7.3. Examples of situations beyond the control of the of the responsible entity (see Section 7.4) include, but are not limited to:

- Delays resulting from regulatory/legal processes, such as permitting;
- Delays resulting from stakeholder processes required by tariff;
- Delays resulting from equipment lead times; or
- Delays resulting from the inability to acquire necessary Right-of-Way.

**R7.** Each responsible entity, as determined in Requirement R1, that concludes through the benchmark GMD Vulnerability Assessment conducted in Requirement R4 that their System does not meet the performance requirements for the steady state planning benchmark GMD event contained in Table 1, shall develop a Corrective Action Plan (CAP) addressing how the performance requirements will be met. The CAP shall: *[Violation Risk Factor: High] [Time Horizon: Long-term Planning]*

**7.1.** List System deficiencies and the associated actions needed to achieve required System performance. Examples of such actions include:

- Installation, modification, retirement, or removal of Transmission and generation Facilities and any associated equipment.
- Installation, modification, or removal of Protection Systems or Remedial Action Schemes.
- Use of Operating Procedures, specifying how long they will be needed as part of the CAP.
- Use of Demand-Side Management, new technologies, or other initiatives.

**7.2.** Be developed within one year of completion of the benchmark GMD Vulnerability Assessment.

**7.3.** Include a timetable, subject to revision by the responsible entity in Part 7.4, for implementing the selected actions from Part 7.1. The timetable shall:



functional entities referenced in the CAP within 90 calendar days of development or revision, and (ii) to any functional entity that submits a written request and has a reliability-related need within 90 calendar days of receipt of such request or within 90 calendar days of development or revision, whichever is later as specified in Requirement R7. Each responsible entity, as determined in Requirement R1, shall also provide evidence, such as email notices or postal receipts showing recipient and date, that it has provided a documented response to comments received on its CAP within 90 calendar days of receipt of those comments, in accordance with Requirement R7.

### **Supplemental GMD Vulnerability Assessment(s)**

**Rationale for Requirements R8 – R10:** The proposed requirements address directives in Order No. 830 for revising the benchmark GMD event used in GMD Vulnerability Assessments (P -44, P47P 47-49). The requirements add a supplemental GMD Vulnerability Assessment based on the supplemental GMD event that accounts for localized peak geoelectric fields.

- R8.** Each responsible entity, as determined in Requirement R1, shall complete a supplemental GMD Vulnerability Assessment of the Near-Term Transmission Planning Horizon at least once every 60 calendar months. This supplemental GMD Vulnerability Assessment shall use a study or studies based on models identified in Requirement R2, document assumptions, and document summarized results of the steady state analysis. [*Violation Risk Factor: High*] [*Time Horizon: Long-term Planning*]
- 8.1.** The study or studies shall include the following conditions:
- 8.1.1.** System On-Peak Load for at least one year within the Near-Term Transmission Planning Horizon; and
  - 8.1.2.** System Off-Peak Load for at least one year within the Near-Term Transmission Planning Horizon.
- 8.2.** The study or studies shall be conducted based on the supplemental GMD event described in Attachment 1 to determine whether the System meets the performance requirements for the steady state planning supplemental GMD event contained in Table 1.
- 8.3.** If the analysis concludes there is Cascading caused by the supplemental GMD event described in Attachment 1, an evaluation of possible actions designed to reduce the likelihood or mitigate the consequences and adverse impacts of the event(s) shall be conducted.

- 8.4.** The supplemental GMD Vulnerability Assessment shall be provided: (i) to the responsible entity's Reliability Coordinator, adjacent Planning Coordinators, adjacent Transmission Planners within 90 calendar days of completion, and (ii) to any functional entity that submits a written request and has a reliability-related need within 90 calendar days of receipt of such request or within 90 calendar days of completion of the supplemental GMD Vulnerability Assessment, whichever is later.
- 8.4.1.** If a recipient of the supplemental GMD Vulnerability Assessment provides documented comments on the results, the responsible entity shall provide a documented response to that recipient within 90 calendar days of receipt of those comments.
- M8.** Each responsible entity, as determined in Requirement R1, shall have dated evidence such as electronic or hard copies of its supplemental GMD Vulnerability Assessment meeting all of the requirements in Requirement R8. Each responsible entity, as determined in Requirement R1, shall also provide evidence, such as email records, web postings with an electronic notice of posting, or postal receipts showing recipient and date, that it has distributed its supplemental GMD Vulnerability: (i) to the responsible entity's Reliability Coordinator, adjacent Planning Coordinators, adjacent Transmission Planners within 90 calendar days of completion, and (ii) to any functional entity that submits a written request and has a reliability-related need within 90 calendar days of receipt of such request or within 90 calendar days of completion of the supplemental GMD Vulnerability Assessment, whichever is later, as specified in Requirement R8. Each responsible entity, as determined in Requirement R1, shall also provide evidence, such as email notices or postal receipts showing recipient and date, that it has provided a documented response to comments received on its supplemental GMD Vulnerability Assessment within 90 calendar days of receipt of those comments in accordance with Requirement R8.
- R9.** Each responsible entity, as determined in Requirement R1, shall provide GIC flow information to be used for the supplemental thermal impact assessment of transformers specified in Requirement R10 to each Transmission Owner and Generator Owner that owns an applicable Bulk Electric System (BES) power transformer in the planning area. The GIC flow information shall include: *[Violation Risk Factor: Medium] [Time Horizon: Long-term Planning]*
- 9.1.** The maximum effective GIC value for the worst case geoelectric field orientation for the supplemental GMD event described in Attachment 1. This value shall be provided to the Transmission Owner or Generator Owner that owns each applicable BES power transformer in the planning area.

- 9.2.** The effective GIC time series, GIC(t), calculated using the supplemental GMD event described in Attachment 1 in response to a written request from the Transmission Owner or Generator Owner that owns an applicable BES power transformer in the planning area. GIC(t) shall be provided within 90 calendar days of receipt of the written request and after determination of the maximum effective GIC value in Part 9.1.
- M9.** Each responsible entity, as determined in Requirement R1, shall provide evidence, such as email records, web postings with an electronic notice of posting, or postal receipts showing recipient and date, that it has provided the maximum effective ~~supplemental~~ GIC ~~value~~ values to the Transmission Owner and Generator Owner that owns each applicable BES power transformer in the planning area as specified in Requirement R9, Part 9.1. Each responsible entity, as determined in Requirement R1, shall also provide evidence, such as email records, web postings with an electronic notice of posting, or postal receipts showing recipient and date, that it has provided GIC(t) in response to a written request from the Transmission Owner or Generator Owner that owns an applicable BES power transformer in the planning area.
- R10.** Each Transmission Owner and Generator Owner shall conduct a supplemental thermal impact assessment for its solely and jointly owned applicable BES power transformers where the maximum effective GIC value provided in Requirement R9, Part 9.1, is 85 A per phase or greater. The supplemental thermal impact assessment shall: *[Violation Risk Factor: Medium] [Time Horizon: Long-term Planning]*
- 10.1.** Be based on the effective GIC flow information provided in Requirement R9;
- 10.2.** Document assumptions used in the analysis;
- 10.3.** Describe suggested actions and supporting analysis to mitigate the impact of GICs, if any; and
- 10.4.** Be performed and provided to the responsible entities, as determined in Requirement R1, within 24 calendar months of receiving GIC flow information specified in Requirement R9, Part 9.1.
- M10.** Each Transmission Owner and Generator Owner shall have evidence such as electronic or hard copies of its supplemental thermal impact assessment for all of its solely and jointly owned applicable BES power transformers where the maximum effective GIC value provided in Requirement R9, Part 9.1, is 85 A per phase or greater, and shall have evidence such as email records, web postings with an electronic notice of posting, or postal receipts showing recipient and date, that it has provided its supplemental thermal impact assessment to the responsible entities as specified in Requirement R10.

### GMD Measurement Data Processes

**Rationale for Requirements R11 and R12:** The proposed requirements address directives in Order No. 830 for requiring responsible entities to collect GIC monitoring and magnetometer data as necessary to enable model validation and situational awareness (P. 88; P. ~~90-92~~, 90-92). GMD measurement data refers to GIC monitor data and geomagnetic field data in Requirements R11 and R12, respectively. See the Guidelines and Technical Basis section of this standard for technical information.

The objective of Requirement R11 is for entities to obtain GIC data for the Planning Coordinator's planning area or other part of the system included in the Planning Coordinator's GIC System model to inform GMD Vulnerability Assessments. Technical considerations for GIC monitoring are contained in Chapter ~~69~~ of the *2012 Special Reliability Assessment Interim Report: Effects of Geomagnetic Disturbances on the Bulk-Power System* (NERC 2012 GMD Report). GIC monitoring is generally performed by Hall effect transducers that are attached to the neutral of the transformer and measure dc current flowing through the neutral.

The objective of Requirement R12 is for entities to obtain geomagnetic field data for the Planning Coordinator's planning area to inform GMD Vulnerability Assessments. Magnetometers provide geomagnetic field data by measuring changes in the earth's magnetic field. Sources of geomagnetic field data include:

- Observatories such as those operated by U.S. Geological Survey, Natural Resources Canada, research organizations, or university research facilities;
- Installed magnetometers; and
- Commercial or third-party sources of geomagnetic field data.

Geomagnetic field data for a Planning Coordinator's planning area is obtained from one or more of the above data sources located in the Planning Coordinator's planning area, or by obtaining a geomagnetic field data product for the Planning Coordinator's planning area from a government or research organization. The geomagnetic field data product does not need to be derived from a magnetometer or observatory within the Planning Coordinator's planning area.

**R11.** Each responsible entity, as determined in Requirement R1, shall implement a process to obtain GIC monitor data from at least one GIC monitor located in the Planning Coordinator's planning area or other part of the system included in the Planning Coordinator's GIC System model. *[Violation Risk Factor: Lower] [Time Horizon: Long-term Planning]*

**M11.** Each responsible entity, as determined in Requirement R1, shall have evidence such as electronic or hard copies of its GIC monitor location(s) and documentation of its process to obtain GIC monitor data in accordance with Requirement R11.

**R12.** Each responsible entity, as determined in Requirement R1, shall implement a process to obtain geomagnetic field data for its Planning Coordinator’s planning area.

*[Violation Risk Factor: Lower] [Time Horizon: Long-term Planning]*

**M12.** Each responsible entity, as determined in Requirement R1, shall have evidence such as electronic or hard copies of its process to obtain geomagnetic field data for its Planning Coordinator’s planning area in accordance with Requirement R12.

## C. Compliance

### 1. Compliance Monitoring Process

**1.1. Compliance Enforcement Authority:** “Compliance Enforcement Authority” means NERC or the Regional Entity, or any entity as otherwise designated by an Applicable Governmental Authority, in their respective roles of monitoring and/or enforcing compliance with mandatory and enforceable Reliability Standards in their respective jurisdictions.

**1.2. Evidence Retention:** The following evidence retention period(s) identify the period of time an entity is required to retain specific evidence to demonstrate compliance. For instances where the evidence retention period specified below is shorter than the time since the last audit, the Compliance Enforcement Authority may ask an entity to provide other evidence to show that it was compliant for the full-time period since the last audit.

The applicable entity shall keep data or evidence to show compliance as identified below unless directed by its Compliance Enforcement Authority to retain specific evidence for a longer period of time as part of an investigation.

- For Requirements R1, R2, R3, R5, R6, R9, and R10, each responsible entity shall retain documentation as evidence for five years.
- For Requirements R4 and R8, each responsible entity shall retain documentation of the current GMD Vulnerability Assessment and the preceding GMD Vulnerability Assessment.
- For Requirement R7, each responsible entity shall retain documentation as evidence for five years or until all actions in the Corrective Action Plan are completed, whichever is later.
- For Requirements R11 and R12, each responsible entity shall retain documentation as evidence for three years.

**1.3. Compliance Monitoring and Enforcement Program:** As defined in the NERC Rules of Procedure, “Compliance Monitoring and Enforcement Program” refers to the identification of the processes that will be used to evaluate data or information for the purpose of assessing performance or outcomes with the associated Reliability Standard.



**Table 1 – Steady State Planning GMD Event**

**Steady State:**

- a. Voltage collapse, Cascading and uncontrolled islanding shall not occur.
- b. Generation loss is acceptable as a consequence of the steady state planning GMD events.
- c. Planned System adjustments such as Transmission configuration changes and re-dispatch of generation are allowed if such adjustments are executable within the time duration applicable to the Facility Ratings.

Category	Initial Condition	Event	Interruption of Firm Transmission Service Allowed	Load Loss Allowed
<b>Benchmark GMD Event - GMD Event with Outages</b>	1. System as may be postured in response to space weather information <sup>1</sup> , and then 2. GMD event <sup>2</sup>	Reactive Power compensation devices and other Transmission Facilities removed as a result of Protection System operation or Misoperation due to harmonics during the GMD event	Yes <sup>3</sup>	Yes <sup>3</sup>
<b>Supplemental GMD Event - GMD Event with Outages</b>	1. System as may be postured in response to space weather information <sup>1</sup> , and then 2. GMD event <sup>2</sup>	Reactive Power compensation devices and other Transmission Facilities removed as a result of Protection System operation or Misoperation due to harmonics during the GMD event	Yes	Yes

**Table 1 – Steady State Performance Footnotes**

- 1. The System condition for GMD planning may include adjustments to posture the System that are executable in response to space weather information.
- 2. The GMD conditions for the benchmark and supplemental planning events are described in Attachment 1.
- 3. Load loss as a result of manual or automatic Load shedding (e.g., UVLS) and/or curtailment of Firm Transmission Service may be used to meet BES performance requirements during studied GMD conditions. The likelihood and magnitude of Load loss or curtailment of Firm Transmission Service should be minimized.

### Violation Severity Levels

R #	Violation Severity Levels			
	Lower VSL	Moderate VSL	High VSL	Severe VSL
R1.	N/A	N/A	N/A	The Planning Coordinator, in conjunction with its Transmission Planner(s), failed to determine and identify individual or joint responsibilities of the Planning Coordinator and Transmission Planner(s) in the Planning Coordinator’s planning area for maintaining models, performing the study or studies needed to complete benchmark and supplemental GMD Vulnerability Assessments, and implementing process(es) to obtain GMD measurement data as specified in this standard.

R #	Violation Severity Levels			
	Lower VSL	Moderate VSL	High VSL	Severe VSL
R2.	N/A	N/A	The responsible entity did not maintain either System models or GIC System models of the responsible entity’s planning area for performing the <del>study or</del> studies needed to complete benchmark and supplemental GMD Vulnerability Assessments.	The responsible entity did not maintain both System models and GIC System models of the responsible entity’s planning area for performing the <del>study or</del> studies needed to complete benchmark and supplemental GMD Vulnerability Assessments.
R3.	N/A	N/A	N/A	The responsible entity did not have criteria for acceptable System steady state voltage performance for its System during the GMD events described in Attachment 1 as required.

R #	Violation Severity Levels			
	Lower VSL	Moderate VSL	High VSL	Severe VSL
R4.	<p>The responsible entity completed a benchmark GMD Vulnerability Assessment, but it was more than 60 calendar months and less than or equal to 64 calendar months since the last benchmark GMD Vulnerability Assessment.</p>	<p>The responsible entity's completed benchmark GMD Vulnerability Assessment failed to satisfy one of <u>the</u> elements listed in Requirement R4, Parts 4.1 through 4.3;</p> <p>OR</p> <p>The responsible entity completed a benchmark GMD Vulnerability Assessment, but it was more than 64 calendar months and less than or equal to 68 calendar months since the last benchmark GMD Vulnerability Assessment.</p>	<p>The responsible entity's completed benchmark GMD Vulnerability Assessment failed to satisfy two of the elements listed in Requirement R4, Parts 4.1 through 4.3;</p> <p>OR</p> <p>The responsible entity completed a benchmark GMD Vulnerability Assessment, but it was more than 68 calendar months and less than or equal to 72 calendar months since the last benchmark GMD Vulnerability Assessment.</p>	<p>The responsible entity's completed benchmark GMD Vulnerability Assessment failed to satisfy three of the elements listed in Requirement R4, Parts 4.1 through 4.3;</p> <p>OR</p> <p>The responsible entity completed a benchmark GMD Vulnerability Assessment, but it was more than 72 calendar months since the last benchmark GMD Vulnerability Assessment;</p> <p>OR</p> <p>The responsible entity does not have a completed benchmark GMD Vulnerability Assessment.</p>

R #	Violation Severity Levels			
	Lower VSL	Moderate VSL	High VSL	Severe VSL
R5.	The responsible entity provided the effective GIC time series, GIC(t), in response to written request, but did so more than 90 calendar days and less than or equal to 100 calendar days after receipt of a written request.	The responsible entity provided the effective GIC time series, GIC(t), in response to written request, but did so more than 100 calendar days and less than or equal to 110 calendar days after receipt of a written request.	The responsible entity provided the effective GIC time series, GIC(t), in response to written request, but did so more than 110 calendar days after receipt of a written request.	The responsible entity did not provide the maximum effective GIC value to the Transmission Owner and Generator Owner that owns each applicable BES power transformer in the planning area; OR The responsible entity did not provide the effective GIC time series, GIC(t), upon written request.

<p><b>R6.</b></p>	<p>The responsible entity failed to conduct a benchmark thermal impact assessment for 5% or less or one of its solely owned and jointly owned applicable BES power transformers (whichever is greater) where the maximum effective GIC value provided in Requirement R5, Part 5.1, is 75 A or greater per phase; OR The responsible entity conducted a benchmark thermal impact assessment for its solely owned and jointly owned applicable BES power transformers where the maximum effective GIC value provided in Requirement R5, Part 5.1, is 75 A or greater per phase but did so more than 24 calendar months and less than or equal to 26 calendar months of receiving GIC flow information specified in Requirement R5, Part 5.1.</p>	<p>The responsible entity failed to conduct a benchmark thermal impact assessment for more than 5% up to (and including) 10% or two of its solely owned and jointly owned applicable BES power transformers (whichever is greater) where the maximum effective GIC value provided in Requirement R5, Part 5.1, is 75 A or greater per phase; OR The responsible entity conducted a benchmark thermal impact assessment for its solely owned and jointly owned applicable BES power transformers where the maximum effective GIC value provided in Requirement R5, Part 5.1, is 75 A or greater per phase but did so more than 26 calendar months and less than or equal to 28 calendar months of receiving GIC flow information specified in Requirement R5, Part 5.1;</p>	<p>The responsible entity failed to conduct a benchmark thermal impact assessment for more than 10% up to (and including) 15% or three of its solely owned and jointly owned applicable BES power transformers (whichever is greater) where the maximum effective GIC value provided in Requirement R5, Part 5.1, is 75 A or greater per phase; OR The responsible entity conducted a benchmark thermal impact assessment for its solely owned and jointly owned applicable BES power transformers where the maximum effective GIC value provided in Requirement R5, Part 5.1, is 75 A or greater per phase but did so more than 28 calendar months and less than or equal to 30 calendar months of receiving GIC flow information specified in Requirement R5, Part 5.1;</p>	<p>The responsible entity failed to conduct a benchmark thermal impact assessment for more than 15% or more than three of its solely owned and jointly owned applicable BES power transformers (whichever is greater) where the maximum effective GIC value provided in Requirement R5, Part 5.1, is 75 A or greater per phase; OR The responsible entity conducted a benchmark thermal impact assessment for its solely owned and jointly owned applicable BES power transformers where the maximum effective GIC value provided in Requirement R5, Part 5.1, is 75 A or greater per phase but did so more than 30 calendar months of receiving GIC flow information specified in Requirement R5, Part 5.1; OR</p>
-------------------	--	--	---	---

R #	Violation Severity Levels			
	Lower VSL	Moderate VSL	High VSL	Severe VSL
		OR The responsible entity failed to include one of the required elements as listed in Requirement R6, Parts 6.1 through 6.3.	OR The responsible entity failed to include two of the required elements as listed in Requirement R6, Parts 6.1 through 6.3.	The responsible entity failed to include three of the required elements as listed in Requirement R6, Parts 6.1 through 6.3.
<b>R7.</b>	The responsible entity's Corrective Action Plan failed to comply with one of the elements in Requirement R7, Parts 7.1 through 7.5.	The responsible entity's Corrective Action Plan failed to comply with two of the elements in Requirement R7, Parts 7.1 through 7.5.	The responsible entity's Corrective Action Plan failed to comply with three of the elements in Requirement R7, Parts 7.1 through 7.5.	The responsible entity's Corrective Action Plan failed to comply with four or more of the elements in Requirement R7, Parts 7.1 through 7.5; OR The responsible entity did not have a Corrective Action Plan as required by Requirement R7.

R #	Violation Severity Levels			
	Lower VSL	Moderate VSL	High VSL	Severe VSL
R8.	<p><u>The responsible entity's completed supplemental GMD Vulnerability Assessment failed to satisfy one of elements listed in Requirement R8, Parts 8.1 through 8.4;</u></p> <p>OR</p> <p>The responsible entity completed a supplemental GMD Vulnerability Assessment, but it was more than 60 calendar months and less than or equal to 64 calendar months since the last supplemental GMD Vulnerability Assessment;</p> <p>OR</p> <p><del>The responsible entity's completed supplemental GMD Vulnerability Assessment failed to satisfy one of elements listed in Requirement R8, Parts 8.1 through 8.4;</del></p>	<p>The responsible entity's completed supplemental GMD Vulnerability Assessment failed to satisfy two of elements listed in Requirement R8, Parts 8.1 through 8.4;</p> <p>OR</p> <p>The responsible entity completed a supplemental GMD Vulnerability Assessment, but it was more than 64 calendar months and less than or equal to 68 calendar months since the last supplemental GMD Vulnerability Assessment.</p>	<p>The responsible entity's completed supplemental GMD Vulnerability Assessment failed to satisfy three of the elements listed in Requirement R8, Parts 8.1 through 8.4;</p> <p>OR</p> <p>The responsible entity completed a supplemental GMD Vulnerability Assessment, but it was more than 68 calendar months and less than or equal to 72 calendar months since the last supplemental GMD Vulnerability Assessment.</p>	<p>The responsible entity's completed supplemental GMD Vulnerability Assessment failed to satisfy four of the elements listed in Requirement R8, Parts 8.1 through 8.4;</p> <p>OR</p> <p>The responsible entity completed a supplemental GMD Vulnerability Assessment, but it was more than 72 calendar months since the last supplemental GMD Vulnerability Assessment;</p> <p>OR</p> <p>The responsible entity does not have a completed supplemental GMD Vulnerability Assessment.</p>



R #	Violation Severity Levels			
	Lower VSL	Moderate VSL	High VSL	Severe VSL
R9.	The responsible entity provided the effective GIC time series, GIC(t), in response to written request, but did so more than 90 calendar days and less than or equal to 100 calendar days after receipt of a written request.	The responsible entity provided the effective GIC time series, GIC(t), in response to written request, but did so more than 100 calendar days and less than or equal to 110 calendar days after receipt of a written request.	The responsible entity provided the effective GIC time series, GIC(t), in response to written request, but did so more than 110 calendar days after receipt of a written request.	The responsible entity did not provide the maximum effective GIC value to the Transmission Owner and Generator Owner that owns each applicable BES power transformer in the planning area; OR The responsible entity did not provide the effective GIC time series, GIC(t), upon written request.

<p><b>R10.</b></p>	<p>The responsible entity failed to conduct a supplemental thermal impact assessment for 5% or less or one of its solely owned and jointly owned applicable BES power transformers (whichever is greater) where the maximum effective GIC value provided in Requirement R9, Part 9.1, is 85 A or greater per phase; OR The responsible entity conducted a supplemental thermal impact assessment for its solely owned and jointly owned applicable BES power transformers where the maximum effective GIC value provided in Requirement R9, Part 9.1, is 85 A or greater per phase but did so more than 24 calendar months and less than or equal to 26 calendar months of receiving GIC flow information specified in Requirement R9, Part 9.1.</p>	<p>The responsible entity failed to conduct a supplemental thermal impact assessment for more than 5% up to (and including) 10% or two of its solely owned and jointly owned applicable BES power transformers (whichever is greater) where the maximum effective GIC value provided in Requirement R9, Part 9.1, is 85 A or greater per phase; OR The responsible entity conducted a supplemental thermal impact assessment for its solely owned and jointly owned applicable BES power transformers where the maximum effective GIC value provided in Requirement R9, Part 9.1, is 85 A or greater per phase but did so more than 26 calendar months and less than or equal to 28 calendar months of receiving GIC flow information specified in Requirement R9, Part 9.1;</p>	<p>The responsible entity failed to conduct a supplemental thermal impact assessment for more than 10% up to (and including) 15% or three of its solely owned and jointly owned applicable BES power transformers (whichever is greater) where the maximum effective GIC value provided in Requirement R9, Part 9.1, is 85 A or greater per phase; OR The responsible entity conducted a supplemental thermal impact assessment for its solely owned and jointly owned applicable BES power transformers where the maximum effective GIC value provided in Requirement R9, Part 9.1, is 85 A or greater per phase but did so more than 28 calendar months and less than or equal to 30 calendar months of receiving GIC flow information specified in Requirement R9, Part 9.1;</p>	<p>The responsible entity failed to conduct a supplemental thermal impact assessment for more than 15% or more than three of its solely owned and jointly owned applicable BES power transformers (whichever is greater) where the maximum effective GIC value provided in Requirement R9, Part 9.1, is 85 A or greater per phase; OR The responsible entity conducted a supplemental thermal impact assessment for its solely owned and jointly owned applicable BES power transformers where the maximum effective GIC value provided in Requirement R9, Part 9.1, is 85 A or greater per phase but did so more than 30 calendar months of receiving GIC flow information specified in Requirement R9, Part 9.1; OR</p>
--------------------	--	--	---	---

R #	Violation Severity Levels			
	Lower VSL	Moderate VSL	High VSL	Severe VSL
		OR The responsible entity failed to include one of the required elements as listed in Requirement R10, Parts 10.1 through 10.3.	OR The responsible entity failed to include two of the required elements as listed in Requirement R10, Parts 10.1 through 10.3.	The responsible entity failed to include three of the required elements as listed in Requirement R10, Parts 10.1 through 10.3.
R11.	N/A	N/A	N/A	The responsible entity did not implement a process to obtain GIC monitor data from at least one GIC monitor located in the Planning Coordinator’s planning area or other part of the system included in the Planning Coordinator’s GIC System Model.
R12.	N/A	N/A	N/A	The responsible entity did not implement a process to obtain geomagnetic field data for its Planning Coordinator’s planning area.

**D. Regional Variances**

None.

**E. Associated Documents**

~~None.~~

Attachment 1

## Version History

Version	Date	Action	Change Tracking
1	December 17, 2014	Adopted by the NERC Board of Trustees	<u>New</u>
2	TBD	Revised to respond to directives in FERC Order No. 830.	Revised

## **Standard Attachments**

The following attachments are part of TPL-007-2.

## Attachment 1

### Calculating Geoelectric Fields for the Benchmark and Supplemental GMD Events

The benchmark GMD event<sup>1</sup> defines the geoelectric field values used to compute GIC flows that are needed to conduct a benchmark GMD Vulnerability Assessment. It is composed of the following elements: (1) a reference peak geoelectric field amplitude of 8 V/km derived from statistical analysis of historical magnetometer data; (2) scaling factors to account for local geomagnetic latitude; (3) scaling factors to account for local earth conductivity; and (4) a reference geomagnetic field time series or waveform to facilitate time-domain analysis of GMD impact on equipment.

The supplemental GMD event is composed of similar elements as described above, except (1) the reference peak geoelectric field amplitude is 12 V/km over a localized area; and (2) the geomagnetic field time series or waveform includes a local enhancement in the waveform.<sup>2</sup>

The regional geoelectric field peak amplitude used in GMD Vulnerability Assessment,  $E_{peak}$ , can be obtained from the reference geoelectric field value of 8 V/km for the benchmark GMD event (1) or 12 V/km for the supplemental GMD event (2) using the following relationships:

$$E_{peak} = 8 \times \alpha \times \beta_b \text{ (V/km)} \quad (1)$$

$$E_{peak} = 12 \times \alpha \times \beta_s \text{ (V/km)} \quad (2)$$

where  $\alpha$  is the scaling factor to account for local geomagnetic latitude, and  $\beta$  is a scaling factor to account for the local earth conductivity structure. Subscripts  $b$  and  $s$  for the  $\beta$  scaling factor denote association with the benchmark or supplemental GMD events, respectively.

### Scaling the Geomagnetic Field

The benchmark and supplemental GMD events are defined for geomagnetic latitude of 60° and must be scaled to account for regional differences based on geomagnetic latitude. Table 2 provides a scaling factor correlating peak geoelectric field to geomagnetic latitude. Alternatively, the scaling factor  $\alpha$  is computed with the empirical expression:

$$\alpha = 0.001 \times e^{(0.115 \times L)} \quad (3)$$

where  $L$  is the geomagnetic latitude in degrees and  $0.1 \leq \alpha \leq 1$ .

<sup>1</sup> The ~~benchmark GMD event description~~ [Benchmark Geomagnetic Disturbance Event Description, May 2016](#) is available on the Related Information ~~page~~ [webpage](#) for TPL-007-1:

[http://www.nerc.com/pa/Stand/TPL0071RD/Benchmark\\_clean\\_May12\\_complete.pdf](http://www.nerc.com/pa/Stand/TPL0071RD/Benchmark_clean_May12_complete.pdf).

<sup>2</sup> The extent of local enhancements is on the order of 100 km in North-South (latitude) direction but longer in East-West (longitude) direction. The local enhancement in the geomagnetic field occurs over the time period of 2-5 minutes. Additional information is available in the Supplemental ~~GMD-Geomagnetic Disturbance~~ [Event Description, October 2017](#) white paper on the Project 2013-03 Geomagnetic Disturbance Mitigation project ~~page~~ [webpage](#):

<http://www.nerc.com/pa/Stand/Pages/Project-2013-03-Geomagnetic-Disturbance-Mitigation.aspx>.

For large planning areas that cover more than one scaling factor from Table 2, the GMD Vulnerability Assessment should be based on a peak geoelectric field that is:

- calculated by using the most conservative (largest) value for  $\alpha$ ; or
- calculated assuming a non-uniform or piecewise uniform geomagnetic field.

<b>Table 2 – Geomagnetic Field Scaling Factors for the Benchmark and Supplemental GMD Events</b>	
<b>Geomagnetic Latitude (Degrees)</b>	<b>Scaling Factor1 (<math>\alpha</math>)</b>
≤ 40	0.10
45	0.2
50	0.3
54	0.5
56	0.6
57	0.7
58	0.8
59	0.9
≥ 60	1.0

### Scaling the Geoelectric Field

The benchmark GMD event is defined for the reference Quebec earth model described in Table 4. The peak geoelectric field,  $E_{peak}$ , used in a GMD Vulnerability Assessment may be obtained by either:

- Calculating the geoelectric field for the ground conductivity in the planning area and the reference geomagnetic field time series scaled according to geomagnetic latitude, using a procedure such as the plane wave method described in the NERC GMD Task Force GIC Application Guide;<sup>3</sup> or
- Using the earth conductivity scaling factor  $\beta$  from Table 3 that correlates to the ground conductivity map in Figure 1 or Figure 2. Along with the scaling factor  $\alpha$  from equation (3) or Table 2,  $\beta$  is applied to the reference geoelectric field using equation (1 or 2, as applicable) to obtain the regional geoelectric field peak amplitude  $E_{peak}$  to be used in GMD Vulnerability Assessments. When a ground conductivity model is not available, the planning entity should use the largest  $\beta$  factor of adjacent physiographic regions or a technically justified value.

<sup>3</sup> Available at the NERC GMD Task Force project [webpage: http://www.nerc.com/comm/PC/Pages/Geomagnetic-Disturbance-Task-Force-\(GMDTF\)-2013.aspx](http://www.nerc.com/comm/PC/Pages/Geomagnetic-Disturbance-Task-Force-(GMDTF)-2013.aspx) ~~page: http://www.nerc.com/comm/PC/Pages/Geomagnetic-Disturbance-Task-Force-(GMDTF)-2013.aspx~~



The earth models used to calculate Table 3 for the United States were obtained from publicly available information published on the U. S. Geological Survey website.<sup>4</sup> The models used to calculate Table 3 for Canada were obtained from Natural Resources Canada (NRCan) and reflect the average structure for large regions. A planner can also use specific earth model(s) with documented justification and the reference geomagnetic field time series to calculate the  $\beta$  factor(s) as follows:

$$\beta_b = E/8 \text{ for the benchmark GMD event} \quad (4)$$

$$\beta_s = E/12 \text{ for the supplemental GMD} \quad (5)$$

where  $E$  is the absolute value of peak geoelectric in V/km obtained from the technically justified earth model and the reference geomagnetic field time series.

For large planning areas that span more than one  $\beta$  scaling factor, the most conservative (largest) value for  $\beta$  may be used in determining the peak geoelectric field to obtain conservative results. Alternatively, a planner could perform analysis using a non-uniform or piecewise uniform geoelectric field.

### **Applying the Localized Peak Geoelectric Field in the Supplemental GMD Event**

The peak geoelectric field of the supplemental GMD event occurs in a localized area.<sup>5</sup> Planners have flexibility to determine how to apply the localized peak geoelectric field over the planning area in performing GIC calculations. Examples of approaches are:

- Apply the peak geoelectric field (12 V/km scaled to the planning area) over the entire planning area;
- Apply a spatially limited (12 V/km scaled to the planning area) peak geoelectric field (e.g., 100 km in North-South latitude direction and 500 km in East-West longitude direction) over a portion(s) of the system, and apply the benchmark GMD event over the rest of the system; or
- Other methods to adjust the benchmark GMD event analysis to account for the localized geoelectric field enhancement of the supplemental GMD event.

---

<sup>4</sup> Available at <http://geomag.usgs.gov/conductivity/>

<sup>5</sup> See the Supplemental Geomagnetic Disturbance Description white paper located on the Project 2013-03 Geomagnetic Disturbance Mitigation project [page webpage: http://www.nerc.com/pa/Stand/Pages/Project-2013-03-Geomagnetic-Disturbance-Mitigation.aspx](http://www.nerc.com/pa/Stand/Pages/Project-2013-03-Geomagnetic-Disturbance-Mitigation.aspx).

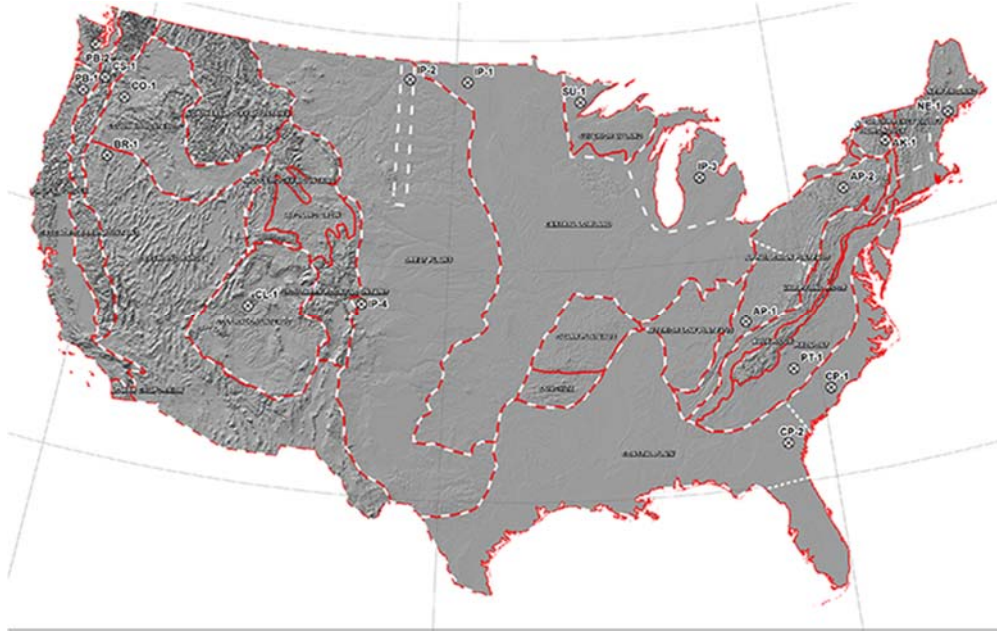


Figure 1: Physiographic Regions of the Continental United States<sup>6</sup>



Figure 2: Physiographic Regions of Canada

<sup>6</sup> Additional map detail is available at the U.S. Geological Survey: <http://geomag.usgs.gov/> ().

<b>Table 3: Goelectric Field Scaling Factors</b>		
<b>Earth model</b>	<b>Scaling Factor Benchmark Event (<math>\beta_b</math>)</b>	<b>Scaling Factor Supplemental Event (<math>\beta_s</math>)</b>
AK1A	0.56	0.51
AK1B	0.56	0.51
AP1	0.33	0.30
AP2	0.82	0.78
BR1	0.22	0.22
CL1	0.76	0.73
CO1	0.27	0.25
CP1	0.81	0.77
CP2	0.95	0.86
FL1	0.76	0.73
CS1	0.41	0.37
IP1	0.94	0.90
IP2	0.28	0.25
IP3	0.93	0.90
IP4	0.41	0.35
NE1	0.81	0.77
PB1	0.62	0.55
PB2	0.46	0.39
PT1	1.17	1.19
SL1	0.53	0.49
SU1	0.93	0.90
BOU	0.28	0.24
FBK	0.56	0.56
PRU	0.21	0.22
BC	0.67	0.62
PRAIRIES	0.96	0.88
SHIELD	1.0	1.0
ATLANTIC	0.79	0.76

**Rationale:** Scaling factors in Table 3 are dependent upon the frequency content of the reference storm. Consequently, the benchmark GMD event and the supplemental GMD event may produce different scaling factors for a given earth model.

The scaling factor associated with the benchmark GMD event for the Florida earth model (~~FL-1~~FL1) has been updated based on the earth model published on the USGS public website.

Layer Thickness (km)	Resistivity ( $\Omega\text{-m}$ )
15	20,000
10	200
125	1,000
200	100
$\infty$	3

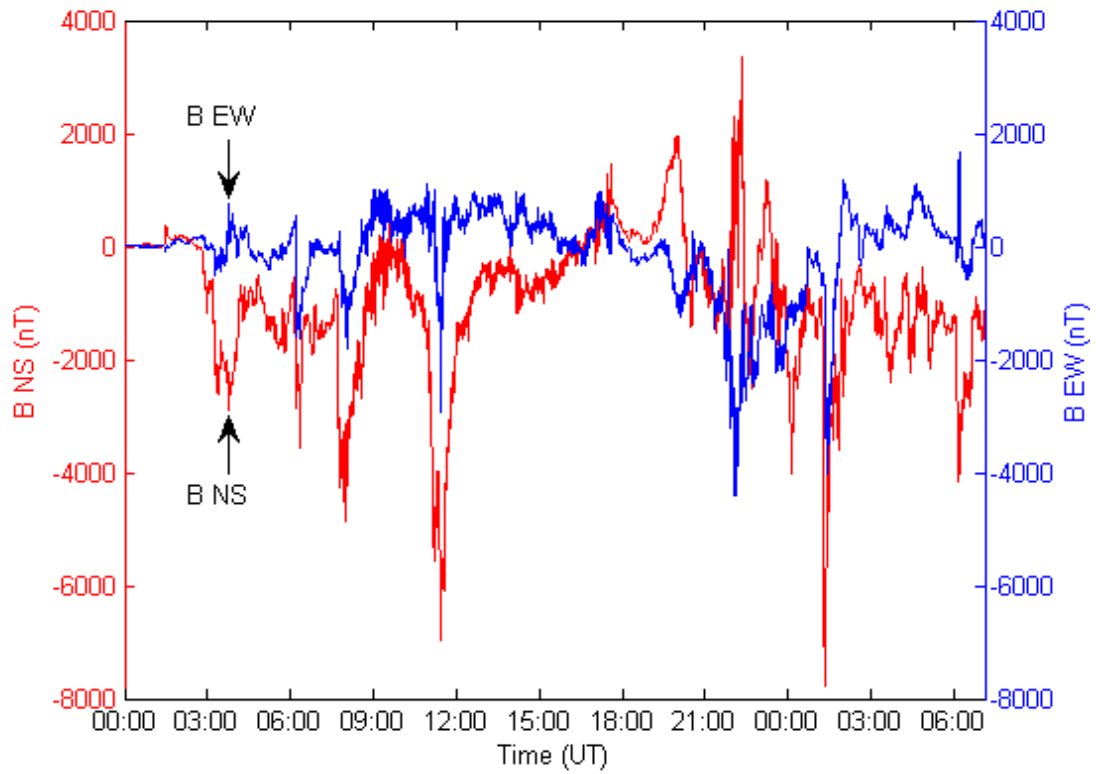
**Reference Geomagnetic Field Time Series or Waveform for the Benchmark GMD Event<sup>7</sup>**

The geomagnetic field measurement record of the March 13-14 1989 GMD event, measured at ~~NRCan's~~the NRCan Ottawa geomagnetic observatory, is the basis for the reference geomagnetic field waveform to be used to calculate the GIC time series, GIC(t), required for transformer thermal impact assessment.

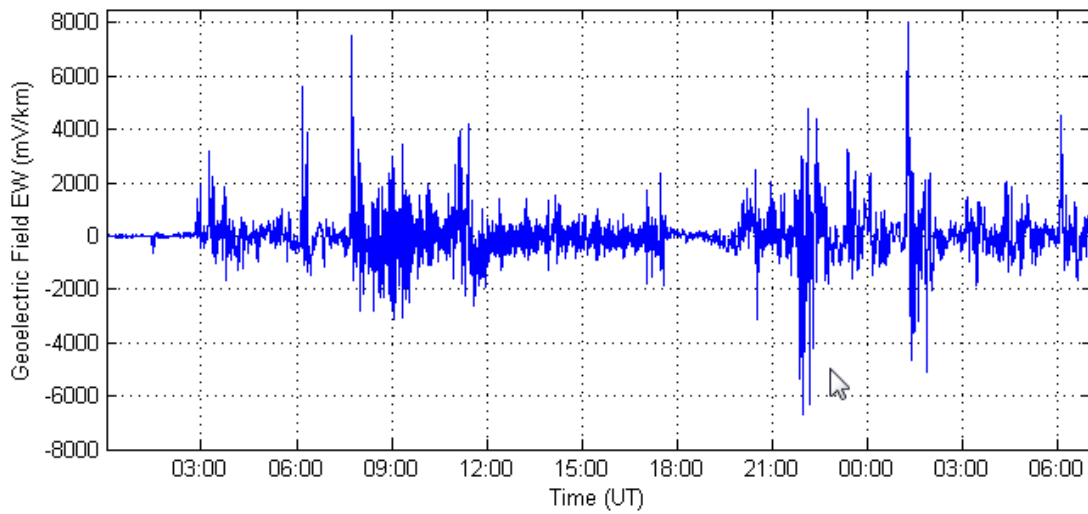
The geomagnetic latitude of the Ottawa geomagnetic observatory is 55°; therefore, the amplitudes of the geomagnetic field measurement data were scaled up to the 60° reference geomagnetic latitude (see Figure 3) such that the resulting peak geoelectric field amplitude computed using the reference earth model was 8 V/km (see Figures 4 and 5). The sampling rate for the geomagnetic field waveform is 10 seconds.<sup>8</sup> To use this geoelectric field time series when a different earth model is applicable, it should be scaled with the appropriate benchmark conductivity scaling factor  $\beta_b$ .

<sup>7</sup> Refer to the Benchmark ~~GMD~~Geomagnetic Disturbance Event Description white paper for details on the determination of the reference geomagnetic field waveform: <http://www.nerc.com/pa/stand/Pages/TPL0071RI.aspx>.

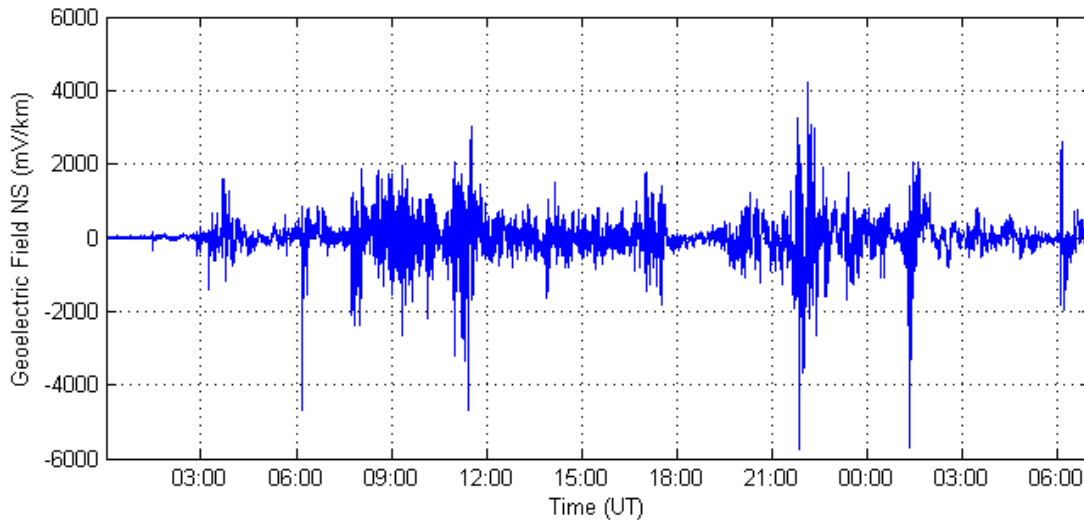
<sup>8</sup> The data file of the benchmark geomagnetic field waveform is available on the Related Information ~~page~~webpage for TPL-007-1: <http://www.nerc.com/pa/stand/Pages/TPL0071RI.aspx>.



**Figure 3: Benchmark Geomagnetic Field Waveform**  
**Red  $B_n$  (Northward), Blue  $B_e$  (Eastward)**



**Figure 4: Benchmark Geoelectric Field Waveform**  
 **$E_E$  (Eastward)**



**Figure 5: Benchmark Geoelectric Field Waveform  
 $E_N$  (Northward)**

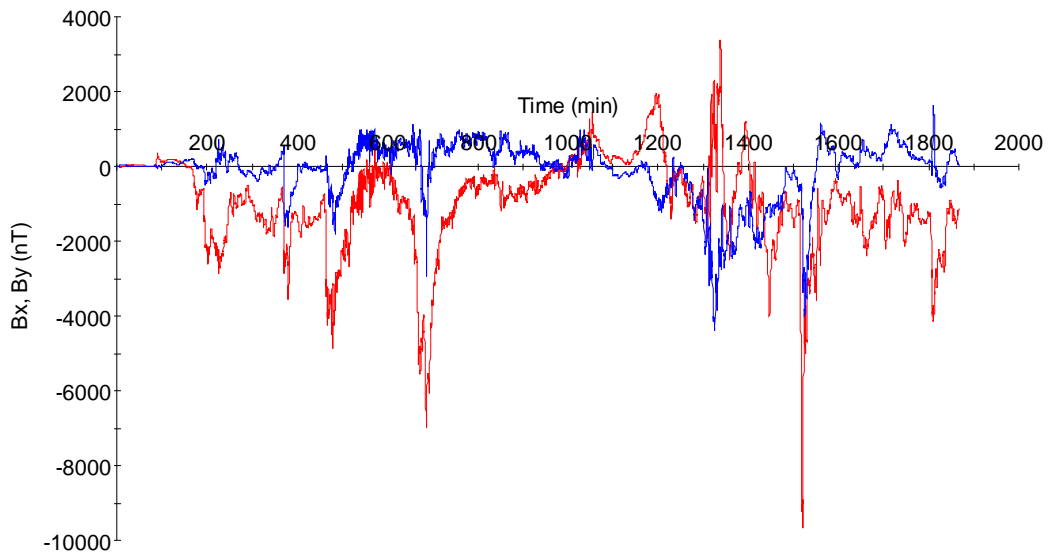
### Reference Geomagnetic Field Time Series or Waveform for the Supplemental GMD Event<sup>9</sup>

The geomagnetic field measurement record of the March 13-14, 1989 GMD event, measured at [NRCan's the NRCan](http://www.nrcan.gc.ca/energy/programs/geomagnetic-observatory) Ottawa geomagnetic observatory, is the basis for the reference geomagnetic field waveform to be used to calculate the GIC time series,  $GIC(t)$ , required for transformer thermal impact assessment for the supplemental GMD event. The supplemental GMD event waveform differs from the benchmark GMD event waveform in that the supplemental GMD event waveform has a local enhancement.

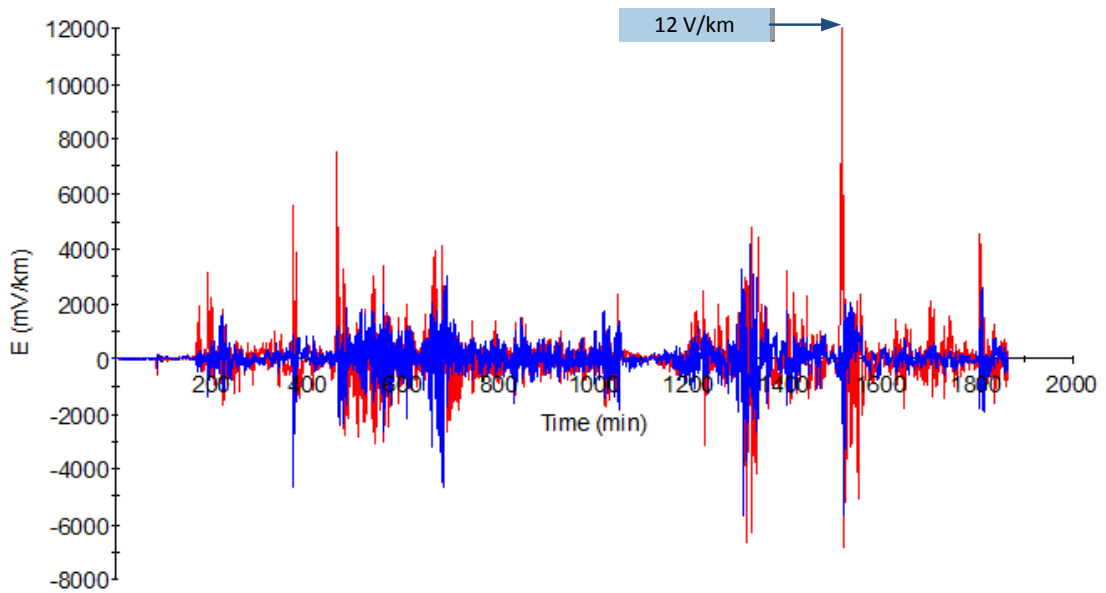
The geomagnetic latitude of the Ottawa geomagnetic observatory is  $55^\circ$ ; therefore, the amplitudes of the geomagnetic field measurement data were scaled up to the  $60^\circ$  reference geomagnetic latitude (see Figure 6) such that the resulting peak geoelectric field amplitude computed using the reference earth model was 12 V/km (see Figure 7). The sampling rate for the geomagnetic field waveform is 10 seconds.<sup>10</sup> To use this geoelectric field time series when a different earth model is applicable, it should be scaled with the appropriate supplemental conductivity scaling factor  $\beta_s$ .

<sup>9</sup> Refer to the Supplemental [GMD Geomagnetic Disturbance](http://www.nrcan.gc.ca/energy/programs/geomagnetic-observatory) Event Description white paper for details on the determination of the reference geomagnetic field waveform: <http://www.nerc.com/pa/Stand/Pages/Project-2013-03-Geomagnetic-Disturbance-Mitigation.aspx>

<sup>10</sup> The data file of the benchmark geomagnetic field waveform is available on the NERC GMD Task Force project [page webpage: http://www.nerc.com/comm/PC/Pages/Geomagnetic-Disturbance-Task-Force-\(GMDTF\)-2013.aspx](http://www.nerc.com/comm/PC/Pages/Geomagnetic-Disturbance-Task-Force-(GMDTF)-2013.aspx).



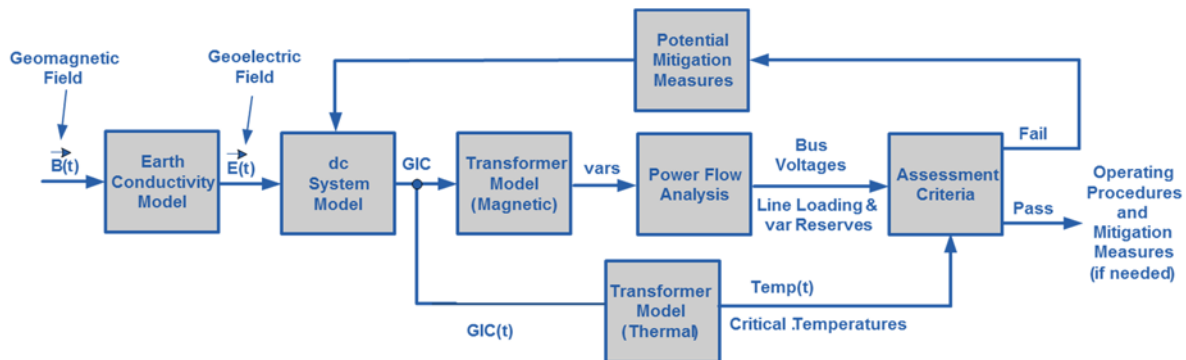
**Figure 6: Supplemental Geomagnetic Field Waveform  
Red  $B_N$  (Northward), Blue  $B_E$  (Eastward)**



**Figure 7: Supplemental Goelectric Field Waveform  
Blue  $E_N$  (Northward), Red  $E_E$  (Eastward)**

## Guidelines and Technical Basis

The diagram below provides an overall view of the GMD Vulnerability Assessment process:



The requirements in this standard cover various aspects of the GMD Vulnerability Assessment process.

### Benchmark GMD Event (Attachment 1)

The benchmark GMD event defines the geoelectric field values used to compute GIC flows that are needed to conduct a benchmark GMD Vulnerability Assessment. ~~A~~[The Benchmark Geomagnetic Disturbance Event Description, May 2016](#)<sup>11</sup> white paper ~~that~~ includes the event description, analysis, and example calculations ~~is available on the Project 2013-03 Geomagnetic Disturbance Mitigation project page at:~~

### Supplemental GMD Event (Attachment 1)

The supplemental GMD event defines the geoelectric field values used to compute GIC flows that are needed to conduct a supplemental GMD Vulnerability Assessment. ~~A~~[The Supplemental Geomagnetic Disturbance Event Description, October 2017](#)<sup>12</sup> white paper ~~that~~ includes the event description and analysis ~~is available on the Project 2013-03 Geomagnetic Disturbance Mitigation project page:~~

### Requirement R2

A GMD Vulnerability Assessment requires a GIC System model, which is a dc representation of the System, to calculate GIC flow. In a GMD Vulnerability Assessment, GIC simulations are used to determine transformer Reactive Power absorption and transformer thermal response. Details for developing the GIC System model are provided in the NERC GMD Task Force guide: *Application Guide for Computing Geomagnetically-Induced Current in the Bulk Power System*. ~~The guide is available at:~~ [December 2013](#).<sup>13</sup>

Underground pipe-type cables present a special modeling situation in that the steel pipe that encloses the power conductors significantly reduces the geoelectric field induced into the

<sup>11</sup> <http://www.nerc.com/pa/stand/Pages/TPL0071RI.aspx>.

<sup>12</sup> <http://www.nerc.com/pa/Stand/Pages/Project-2013-03-Geomagnetic-Disturbance-Mitigation.aspx>.

<sup>13</sup> [http://www.nerc.com/comm/PC/Geomagnetic%20Disturbance%20Task%20Force%20GMDTF%202013/GIC%20Application%20Guide%202013\\_approved.pdf](http://www.nerc.com/comm/PC/Geomagnetic%20Disturbance%20Task%20Force%20GMDTF%202013/GIC%20Application%20Guide%202013_approved.pdf).



conductors themselves, while they remain a path for GIC. Solid dielectric cables that are not enclosed by a steel pipe will not experience a reduction in the induced geoelectric field. A planning entity should account for special modeling situations in the GIC system model, if applicable.

#### **Requirement R4**

The ~~GMD~~Geomagnetic Disturbance Planning Guide,<sup>14</sup> December 2013 developed by the NERC GMD Task Force provides technical information on GMD-specific considerations for planning studies. ~~It is available at:~~

#### **Requirement R5**

The benchmark thermal impact assessment of transformers specified in Requirement R6 is based on GIC information for the benchmark GMD Event. This GIC information is determined by the planning entity through simulation of the GIC System model and must be provided to the entity responsible for conducting the thermal impact assessment. GIC information should be provided in accordance with Requirement R5 each time the GMD Vulnerability Assessment is performed since, by definition, the GMD Vulnerability Assessment includes a documented evaluation of susceptibility to localized equipment damage due to GMD.

The maximum effective GIC value provided in Part 5.1 is used for the benchmark thermal impact assessment. Only those transformers that experience an effective GIC value of 75 A or greater per phase require evaluation in Requirement R6.

GIC(t) provided in Part 5.2 is used to convert the steady state GIC flows to time-series GIC data for the benchmark thermal impact assessment of transformers. This information may be needed by one or more of the methods for performing a benchmark thermal impact assessment. Additional information is in the following section and the ~~thermal impact assessment white paper~~Transformer Thermal Impact Assessment White Paper,<sup>15</sup> October 2017.

The peak GIC value of 75 Amps per phase has been shown through thermal modeling to be a conservative threshold below which the risk of exceeding known temperature limits established by technical organizations is low.

#### **Requirement R6**

The benchmark thermal impact assessment of a power transformer may be based on manufacturer-provided GIC capability curves, thermal response simulation, thermal impact screening, or other technically justified means. Approaches for conducting the assessment are presented in the ~~Transformer Thermal Impact Assessment white paper. The~~White Paper ERO enterprise has endorsed the white paper asEnterprise-Endorsed Implementation Guidance<sup>16</sup> for

---

<sup>14</sup> [http://www.nerc.com/comm/PC/Geomagnetic%20Disturbance%20Task%20Force%20GMDTF%202013/GMD%20Planning%20Guide\\_approved.pdf](http://www.nerc.com/comm/PC/Geomagnetic%20Disturbance%20Task%20Force%20GMDTF%202013/GMD%20Planning%20Guide_approved.pdf).

<sup>15</sup> <http://www.nerc.com/pa/Stand/Pages/Project-2013-03-Geomagnetic-Disturbance-Mitigation.aspx>.

<sup>16</sup> [http://www.nerc.com/pa/comp/guidance/EROEndorsedImplementationGuidance/TPL-007-1\\_Transformer\\_Thermal\\_Impact\\_Assessment\\_White\\_Paper.pdf](http://www.nerc.com/pa/comp/guidance/EROEndorsedImplementationGuidance/TPL-007-1_Transformer_Thermal_Impact_Assessment_White_Paper.pdf).

this requirement. ~~The white paper~~ This ERO-Endorsed document is posted on the NERC ~~compliance guidance page:~~ Compliance Guidance<sup>17</sup> webpage.

~~<http://www.nerc.com/pa/comp/guidance/Pages/default.aspx>~~

Transformers are exempt from the benchmark thermal impact assessment requirement if the effective GIC value for the transformer is less than 75 A per phase, as determined by a GIC analysis of the System. Justification for this criterion is provided in the *Screening Criterion for Transformer Thermal Impact Assessment* ~~white paper posted on the Related Information page for TPL-007-1-White Paper,~~<sup>18</sup> October 2017. A documented design specification exceeding this value is also a justifiable threshold criterion that exempts a transformer from Requirement R6.

The benchmark threshold criteria and its associated transformer thermal impact must be evaluated on the basis of effective GIC. Refer to the white papers for additional information.

### **Requirement R7**

Technical considerations for GMD mitigation planning, including operating and equipment strategies, are available in Chapter 5 of the ~~GMD~~ Geomagnetic Disturbance Planning Guide,<sup>19</sup> December 2013. Additional information is available in the *2012 Special Reliability Assessment Interim Report: Effects of Geomagnetic Disturbances on the Bulk-Power System*,<sup>20</sup> February 2012.

### **Requirement R8**

The ~~GMD~~ Geomagnetic Disturbance Planning Guide,<sup>21</sup> December 2013 developed by the NERC GMD Task Force provides technical information on GMD-specific considerations for planning studies. ~~It is available at:~~

The supplemental GMD Vulnerability Assessment process is similar to the benchmark GMD Vulnerability Assessment process described under Requirement R4.

### **Requirement R9**

The supplemental thermal impact assessment specified of transformers in Requirement R10 is based on GIC information for the supplemental GMD Event. This GIC information is determined by the planning entity through simulation of the GIC System model and must be provided to the entity responsible for conducting the thermal impact assessment. GIC information should be provided in accordance with Requirement R9 each time the GMD Vulnerability Assessment is performed since, by definition, the GMD Vulnerability Assessment includes a documented evaluation of susceptibility to localized equipment damage due to GMD.

---

<sup>17</sup> <http://www.nerc.com/pa/comp/guidance/Pages/default.aspx>.

<sup>18</sup> <http://www.nerc.com/pa/Stand/Pages/Project-2013-03-Geomagnetic-Disturbance-Mitigation.aspx>.

<sup>19</sup> [http://www.nerc.com/comm/PC/Geomagnetic%20Disturbance%20Task%20Force%20GMDTF%202013/GMD%20Planning%20Guide\\_approved.pdf](http://www.nerc.com/comm/PC/Geomagnetic%20Disturbance%20Task%20Force%20GMDTF%202013/GMD%20Planning%20Guide_approved.pdf).

<sup>20</sup> <http://www.nerc.com/pa/RAPA/ra/Reliability%20Assessments%20DL/2012GMD.pdf>.

<sup>21</sup> [http://www.nerc.com/comm/PC/Geomagnetic%20Disturbance%20Task%20Force%20GMDTF%202013/GMD%20Planning%20Guide\\_approved.pdf](http://www.nerc.com/comm/PC/Geomagnetic%20Disturbance%20Task%20Force%20GMDTF%202013/GMD%20Planning%20Guide_approved.pdf).

The maximum effective GIC value provided in Part 9.1 is used for the supplemental thermal impact assessment. Only those transformers that experience an effective GIC value of 85 A or greater per phase require evaluation in Requirement R10.

GIC(t) provided in Part 9.2 is used to convert the steady state GIC flows to time-series GIC data for the supplemental thermal impact assessment of transformers. This information may be needed by one or more of the methods for performing a supplemental thermal impact assessment. Additional information is in the following section.

The peak GIC value of 85 Amps per phase has been shown through thermal modeling to be a conservative threshold below which the risk of exceeding known temperature limits established by technical organizations is low.

### **Requirement R10**

The supplemental thermal impact assessment of a power transformer may be based on manufacturer-provided GIC capability curves, thermal response simulation, thermal impact screening, or other technically justified means. Approaches for conducting the assessment are presented in the *Transformer Thermal Impact Assessment ~~white paper~~ White Paper ERO Enterprise-Endorsed Implementation Guidance*<sup>22</sup> discussed in the Requirement R6 section above. A ~~revised~~ later version of the *Transformer Thermal Impact Assessment ~~white paper~~ White Paper*,<sup>23</sup> October 2017, has been developed to include updated information pertinent to the supplemental GMD event and supplemental thermal impact assessment. ~~This revised white paper is posted on the project page at:~~

Transformers are exempt from the supplemental thermal impact assessment requirement if the effective GIC value for the transformer is less than 85 A per phase, as determined by a GIC analysis of the System. Justification for this criterion is provided in the revised *Screening Criterion for Transformer Thermal Impact Assessment ~~white paper posted on the project page~~ White Paper*,<sup>24</sup> October 2017. A documented design specification exceeding this value is also a justifiable threshold criterion that exempts a transformer from Requirement R10.

The supplemental threshold criteria and its associated transformer thermal impact must be evaluated on the basis of effective GIC. Refer to the white papers for additional information.

### **Requirement R11**

Technical considerations for GIC monitoring are contained in Chapter 6 of the ~~NERC-2012 GMD~~ Special Reliability Assessment Interim Report (see Chapter 6): Effects of Geomagnetic Disturbances on the Bulk-Power System,<sup>25</sup> February 2012. GIC monitoring is generally performed

---

<sup>22</sup> [http://www.nerc.com/pa/comp/guidance/EROEndorsedImplementationGuidance/TPL-007-1 Transformer Thermal Impact Assessment White Paper.pdf](http://www.nerc.com/pa/comp/guidance/EROEndorsedImplementationGuidance/TPL-007-1_Transformer_Thermal_Impact_Assessment_White_Paper.pdf)

<sup>23</sup> <http://www.nerc.com/pa/Stand/Pages/Project-2013-03-Geomagnetic-Disturbance-Mitigation.aspx>

<sup>24</sup> <http://www.nerc.com/pa/Stand/Pages/Project-2013-03-Geomagnetic-Disturbance-Mitigation.aspx>

<sup>25</sup> <http://www.nerc.com/pa/RAPA/ra/Reliability%20Assessments%20DL/2012GMD.pdf>

by Hall effect transducers that are attached to the neutral of the wye-grounded transformer. Data from GIC monitors is useful for model validation and situational awareness.

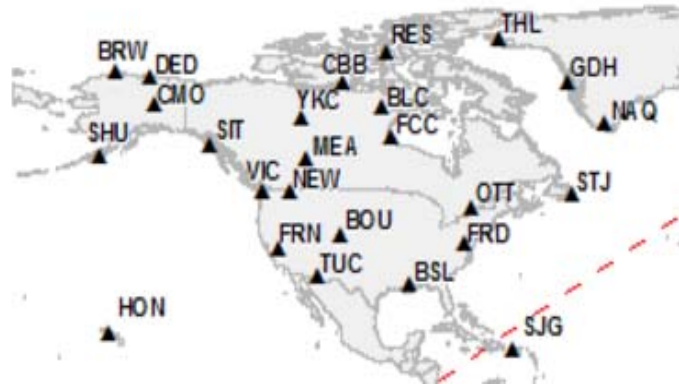
Responsible entities consider the following in developing a process for obtaining GIC monitor data:

- **Monitor locations.** An entity's operating process may be constrained by location of existing GIC monitors. However, when planning for additional GIC monitoring installations consider that data from monitors located in areas found to have high GIC based on system studies may provide more useful information for validation and situational awareness purposes. Conversely, data from GIC monitors that are located in the vicinity of transportation systems using direct current (e.g., subways or light rail) may be unreliable.
- **Monitor specifications.** Capabilities of Hall effect transducers, existing and planned, should be considered in the operating process. When planning new GIC monitor installations, consider monitor data range (e.g., -500 A through + 500 A) and ambient temperature ratings consistent with temperatures in the region in which the monitor will be installed.
- **Sampling Interval.** An entity's operating process may be constrained by capabilities of existing GIC monitors. However, when possible specify data sampling during periods of interest at a rate of 10 seconds or faster.
- **Collection Periods.** The process should specify when the entity expects GIC data to be collected. For example, collection could be required during periods where the Kp index is above a threshold, or when GIC values are above a threshold. Determining when to discontinue collecting GIC data should also be specified to maintain consistency in data collection.
- **Data format.** Specify time and value formats. For example, Greenwich Mean Time (GMT) (MM/DD/YYYY HH:MM:SS) and GIC Value (Ampere). Positive (+) and negative (-) signs indicate direction of GIC flow. Positive reference is flow from ground into transformer neutral. Time fields should indicate the sampled time rather than system or SCADA time if supported by the GIC monitor system.
- **Data retention.** The entity's process should specify data retention periods, for example 1 year. Data retention periods should be adequately long to support availability for the entity's model validation process and external reporting requirements, if any.
- **Additional information.** The entity's process should specify collection of other information necessary for making the data useful, for example monitor location and type of neutral connection (e.g., three-phase or single-phase).

## Requirement R12

Magnetometers measure changes in the earth's magnetic field. Entities should obtain data from the nearest accessible magnetometer. Sources of magnetometer data include:

- Observatories such as those operated by U.S. Geological Survey and Natural Resources Canada, see figure below for locations <sup>(-):26</sup>



- Research institutions and academic universities;
- Entities with installed magnetometers.

Entities that choose to install magnetometers should consider equipment specifications and data format protocols contained in the latest version of the ~~Intermagnet~~INTERMAGNET *Technical Reference Manual*, ~~which is available at:~~Version 4.6, 2012.<sup>27</sup>

## Rationale

During development of TPL-007-1, text boxes were embedded within the standard to explain the rationale for various parts of the standard. The text from the rationale text boxes was moved to this section upon approval of TPL-007-1 by the NERC Board of Trustees. In developing TPL-007-2, the SDT has made changes to the sections below only when necessary for clarity. Changes are marked with brackets [ ].

### Rationale for Applicability:

Instrumentation transformers and station service transformers do not have significant impact on geomagnetically-induced current (GIC) flows; therefore, these transformers are not included in the applicability for this standard.

Terminal voltage describes line-to-line voltage.

<sup>26</sup> <http://www.intermagnet.org/index-eng.php>.

<sup>27</sup> [http://www.intermagnet.org/publications/intermag\\_4-6.pdf](http://www.intermagnet.org/publications/intermag_4-6.pdf).

**Rationale for R1:**

In some areas, planning entities may determine that the most effective approach to conduct a GMD Vulnerability Assessment is through a regional planning organization. No requirement in the standard is intended to prohibit a collaborative approach where roles and responsibilities are determined by a planning organization made up of one or more Planning Coordinator(s).

**Rationale for R2:**

A GMD Vulnerability Assessment requires a GIC System model to calculate GIC flow which is used to determine transformer Reactive Power absorption and transformer thermal response. Guidance for developing the GIC System model is provided in the ~~GIC Application Guide Computing Geomagnetically-Induced Current in the Bulk-Power System,~~<sup>28</sup> December 2013, developed by the NERC GMD Task Force ~~and available at: -~~.

The System model specified in Requirement R2 is used in conducting steady state power flow analysis that accounts for the Reactive Power absorption of power transformer(s) due to GIC in the System.

The GIC System model includes all power transformer(s) with a high side, wye-grounded winding with terminal voltage greater than 200 kV. The model is used to calculate GIC flow in the network.

The projected System condition for GMD planning may include adjustments to the System that are executable in response to space weather information. These adjustments could include, for example, recalling or postponing maintenance outages.

The Violation Risk Factor (VRF) for Requirement R2 is changed from Medium to High. This change is for consistency with the VRF for approved standard TPL-001-4 Requirement R1, which is proposed for revision in the NERC filing dated August 29, 2014 ([Docket No. RM12-1-000](#)). NERC guidelines require consistency among Reliability Standards.

**Rationale for R3:**

Requirement R3 allows a responsible entity the flexibility to determine the System steady state voltage criteria for System steady state performance in Table 1. Steady state voltage limits are an example of System steady state performance criteria.

**Rationale for R4:**

The GMD Vulnerability Assessment includes steady state power flow analysis and the supporting study or studies using the models specified in Requirement R2 that account for the effects of GIC. Performance criteria are specified in Table 1.

At least one System On-Peak Load and at least one System Off-Peak Load must be examined in the analysis.

---

<sup>28</sup> [http://www.nerc.com/comm/PC/Geomagnetic%20Disturbance%20Task%20Force%20GMDTF%202013/GIC%20Application%20Guide%202013\\_approved.pdf](http://www.nerc.com/comm/PC/Geomagnetic%20Disturbance%20Task%20Force%20GMDTF%202013/GIC%20Application%20Guide%202013_approved.pdf).

Distribution of GMD Vulnerability Assessment results provides a means for sharing relevant information with other entities responsible for planning reliability. Results of GIC studies may affect neighboring systems and should be taken into account by planners.

The ~~GMD~~*Geomagnetic Disturbance Planning Guide*,<sup>29</sup> December 2013 developed by the NERC GMD Task Force provides technical information on GMD-specific considerations for planning studies. ~~It is available at:~~

The provision of information in Requirement R4, Part 4.3, shall be subject to the legal and regulatory obligations for the disclosure of confidential and/or sensitive information.

**Rationale for R5:**

This GIC information is necessary for determining the thermal impact of GIC on transformers in the planning area and must be provided to entities responsible for performing the thermal impact assessment so that they can accurately perform the assessment. GIC information should be provided in accordance with Requirement R5 as part of the GMD Vulnerability Assessment process since, by definition, the GMD Vulnerability Assessment includes documented evaluation of susceptibility to localized equipment damage due to GMD.

The maximum effective GIC value provided in Part 5.1 is used for transformer thermal impact assessment.

GIC(t) provided in Part 5.2 can alternatively be used to convert the steady state GIC flows to time-series GIC data for transformer thermal impact assessment. This information may be needed by one or more of the methods for performing a thermal impact assessment. Additional guidance is available in the *Transformer Thermal Impact Assessment* ~~white paper-~~ White Paper,<sup>30</sup> October 2017.

<http://www.nerc.com/pa/comp/guidance/Pages/default.aspx>

A Transmission Owner or Generator Owner that desires GIC(t) may request it from the planning entity. The planning entity shall provide GIC(t) upon request once GIC has been calculated, but no later than 90 calendar days after receipt of a request from the owner and after completion of Requirement R5, Part 5.1.

The provision of information in Requirement R5 shall be subject to the legal and regulatory obligations for the disclosure of confidential and/or sensitive information.

**Rationale for R6:**

The transformer thermal impact screening criterion has been revised from 15 A per phase to 75 A per phase [for the benchmark GMD event]. Only those transformers that experience an effective GIC value of 75 A per phase or greater require evaluation in Requirement R6. The

---

<sup>29</sup> [http://www.nerc.com/comm/PC/Geomagnetic%20Disturbance%20Task%20Force%20GMDTF%202013/GMD%20Planning%20Guide\\_approved.pdf](http://www.nerc.com/comm/PC/Geomagnetic%20Disturbance%20Task%20Force%20GMDTF%202013/GMD%20Planning%20Guide_approved.pdf)

<sup>30</sup> <http://www.nerc.com/pa/Stand/Pages/Project-2013-03-Geomagnetic-Disturbance-Mitigation.aspx>

justification is provided in the ~~Thermal Screening Criterion white paper~~ for Transformer Thermal Impact Assessment White Paper,<sup>31</sup> October 2017.

The thermal impact assessment may be based on manufacturer-provided GIC capability curves, thermal response simulation, thermal impact screening, or other technically justified means. The transformer thermal assessment will be repeated or reviewed using previous assessment results each time the planning entity performs a GMD Vulnerability Assessment and provides GIC information as specified in Requirement R5. Approaches for conducting the assessment are presented in the ~~Transformer Thermal Impact Assessment white paper posted on the project page~~ White Paper,<sup>32</sup> October 2017.

Thermal impact assessments are provided to the planning entity, as determined in Requirement R1, so that identified issues can be included in the GMD Vulnerability Assessment (R4), and the Corrective Action Plan (R7) as necessary.

Thermal impact assessments of non-BES transformers are not required because those transformers do not have a wide-area effect on the reliability of the interconnected Transmission system.

The provision of information in Requirement R6, Part 6.4, shall be subject to the legal and regulatory obligations for the disclosure of confidential and/or sensitive information.

#### **Rationale for R7:**

Corrective Action Plans are defined in the NERC Glossary of Terms:

*A list of actions and an associated timetable for implementation to remedy a specific problem.*

Corrective Action Plans must, subject to the vulnerabilities identified in the assessments, contain strategies for protecting against the potential impact of the benchmark GMD event, based on factors such as the age, condition, technical specifications, system configuration, or location of specific equipment. Chapter 5 of the NERC GMD Task Force ~~GMD~~ Geomagnetic Disturbance Planning Guide,<sup>33</sup> December 2013 provides a list of mitigating measures that may be appropriate to address an identified performance issue.

The provision of information in Requirement R7, Part 7.3 [Part 7.5 in TPL-007-2], shall be subject to the legal and regulatory obligations for the disclosure of confidential and/or sensitive information.

---

<sup>31</sup> <http://www.nerc.com/pa/Stand/Pages/Project-2013-03-Geomagnetic-Disturbance-Mitigation.aspx>.

<sup>32</sup> <http://www.nerc.com/pa/Stand/Pages/Project-2013-03-Geomagnetic-Disturbance-Mitigation.aspx>.

<sup>33</sup> [http://www.nerc.com/comm/PC/Geomagnetic%20Disturbance%20Task%20Force%20GMDTF%202013/GMD%20Planning%20Guide\\_approved.pdf](http://www.nerc.com/comm/PC/Geomagnetic%20Disturbance%20Task%20Force%20GMDTF%202013/GMD%20Planning%20Guide_approved.pdf).



**Rationale for Table 3:**

Table 3 has been revised to use the same ground model designation, FL1, as is being used by USGS. The calculated scaling factor for FL1 is 0.74. [The scaling factor associated with the benchmark GMD event for the Florida earth model (FL1) has been updated to 0.76 in TPL-007-2 based on the earth model published on the USGS public website.]

## **Standard Development Timeline**

This section is maintained by the drafting team during the development of the standard and will be removed when the standard is adopted by the NERC Board of Trustees (Board).

### **Description of Current Draft**

<b><u>Completed Actions</u></b>	<b><u>Date</u></b>
<u>Standards Committee approved Standard Authorization Request (SAR) for posting</u>	<u>December 14, 2016</u>
<u>SAR posted for comment</u>	<u>December 16, 2016 – January 20, 2017</u>
<u>45-day formal comment period with initial ballot</u>	<u>June 28 – August 11, 2017</u>

<b><u>Anticipated Actions</u></b>	<b><u>Date</u></b>
<u>10-day final ballot</u>	<u>October 2017</u>
<u>Board adoption</u>	<u>November 2017</u>

### **New or Modified Term(s) Used in NERC Reliability Standards**

This section includes all new or modified terms used in the proposed standard that will be included in the *Glossary of Terms Used in NERC Reliability Standards* upon applicable regulatory approval. Terms used in the proposed standard that are already defined and are not being modified can be found in the *Glossary of Terms Used in NERC Reliability Standards*. The new or revised terms listed below will be presented for approval with the proposed standard. Upon Board adoption, this section will be removed.

**Term(s):**

None

Upon Board adoption, the rationale boxes will be moved to the Supplemental Material Section.

## A. Introduction

1. **Title:** Transmission System Planned Performance for Geomagnetic Disturbance Events
2. **Number:** TPL-007-~~1~~2
3. **Purpose:** Establish requirements for Transmission system planned performance during geomagnetic disturbance (GMD) events.
4. **Applicability:**
  - 4.1. **Functional Entities:**
    - 4.1.1. Planning Coordinator with a planning area that includes a Facility or Facilities specified in 4.2;
    - 4.1.2. Transmission Planner with a planning area that includes a Facility or Facilities specified in 4.2;
    - 4.1.3. Transmission Owner who owns a Facility or Facilities specified in 4.2; and
    - 4.1.4. Generator Owner who owns a Facility or Facilities specified in 4.2.
  - 4.2. **Facilities:**
    - 4.2.1. Facilities that include power transformer(s) with a high side, wye-grounded winding with terminal voltage greater than 200 kV.
5. Effective Date: See Implementation Plan for TPL-007-2.
- ~~5.6.~~ **Background:** During a GMD event, geomagnetically-induced currents (GIC) may cause transformer hot-spot heating or damage, loss of Reactive Power sources, increased Reactive Power demand, and Misoperation(s), the combination of which may result in voltage collapse and blackout.
- ~~6.~~ **Effective Date:**  
See Implementation Plan for TPL-007-1

## B. Requirements and Measures

- R1. Each Planning Coordinator, in conjunction with its Transmission Planner(s), shall identify the individual and joint responsibilities of the Planning Coordinator and Transmission Planner(s) in the Planning Coordinator's planning area for maintaining models ~~and~~, performing the study or studies needed to complete benchmark and supplemental GMD Vulnerability Assessment(s). Assessments, and implementing process(es) to obtain GMD measurement data as specified in this standard. [Violation Risk Factor: Lower] [Time Horizon: Long-term Planning]

- M1.** ~~M1.~~ Each Planning Coordinator, in conjunction with its Transmission Planners, shall provide documentation on roles and responsibilities, such as meeting minutes, agreements, copies of procedures or protocols in effect between entities or between departments of a vertically integrated system, or email correspondence that identifies an agreement has been reached on individual and joint responsibilities for maintaining models ~~and,~~ performing the study or studies needed to complete benchmark and supplemental GMD Vulnerability ~~Assessment(s), Assessments, and implementing process(es) to obtain GMD measurement data~~ in accordance with Requirement R1.
- R2.** Each responsible entity, as determined in Requirement R1, shall maintain System models and GIC System models of the responsible entity's planning area for performing the study or studies needed to complete benchmark and supplemental GMD Vulnerability ~~Assessment(s), Assessments.~~ *[Violation Risk Factor: High] [Time Horizon: Long-term Planning]*
- M2.** ~~M2.~~ Each responsible entity, as determined in Requirement R1, shall have evidence in either electronic or hard copy format that it is maintaining System models and GIC System models of the responsible entity's planning area for performing the study or studies needed to complete benchmark and supplemental GMD Vulnerability ~~Assessment(s), Assessments.~~
- R3.** Each responsible entity, as determined in Requirement R1, shall have criteria for acceptable System steady state voltage performance for its System during the ~~benchmark~~ GMD ~~event~~ events described in Attachment 1. *[Violation Risk Factor: Medium] [Time Horizon: Long-term Planning]*
- M3.** ~~M3.~~ Each responsible entity, as determined in Requirement R1, shall have evidence, such as electronic or hard copies of the criteria for acceptable System steady state voltage performance for its System in accordance with Requirement R3.

### **Benchmark GMD Vulnerability Assessment(s)**

- R4.** Each responsible entity, as determined in Requirement R1, shall complete a benchmark GMD Vulnerability Assessment of the Near-Term Transmission Planning Horizon at least once every 60 calendar months. This benchmark GMD Vulnerability Assessment shall use a study or studies based on models identified in Requirement R2, document assumptions, and document summarized results of the steady state analysis. *[Violation Risk Factor: High] [Time Horizon: Long-term Planning]*
- 4.1.** The study or studies shall include the following conditions:
- 4.1.1.** System On-Peak Load for at least one year within the Near-Term Transmission Planning Horizon; and
  - 4.1.2.** System Off-Peak Load for at least one year within the Near-Term Transmission Planning Horizon.

- 4.2. The study or studies shall be conducted based on the benchmark GMD event described in Attachment 1 to determine whether the System meets the performance requirements for the steady state planning benchmark GMD event contained in Table 1.
- 4.3. The benchmark GMD Vulnerability Assessment shall be provided ~~within 90 calendar days of completion: (i)~~ to the responsible entity's Reliability Coordinator, adjacent Planning Coordinators, and adjacent Transmission Planners, ~~and within 90 calendar days of completion, and (ii)~~ to any functional entity that submits a written request and has a reliability-related need within 90 calendar days of receipt of such request or within 90 calendar days of completion of the benchmark GMD Vulnerability Assessment, whichever is later.
- 4.3.1. ~~4.3.1.~~ If a recipient of the benchmark GMD Vulnerability Assessment provides documented comments on the results, the responsible entity shall provide a documented response to that recipient within 90 calendar days of receipt of those comments.
- M4. ~~M4.~~ Each responsible entity, as determined in Requirement R1, shall have dated evidence such as electronic or hard copies of its benchmark GMD Vulnerability Assessment meeting all of the requirements in Requirement R4. Each responsible entity, as determined in Requirement R1, shall also provide evidence, such as email records, web postings with an electronic notice of posting, or postal receipts showing recipient and date, that it has distributed its benchmark GMD Vulnerability Assessment ~~within 90 calendar days of completion: (i)~~ to ~~its~~ the responsible entity's Reliability Coordinator, adjacent Planning ~~Coordinator(s), Coordinators, and~~ adjacent Transmission ~~Planner(s), and Planners~~ within 90 calendar days of completion, and (ii) to any functional entity ~~who has submitted~~ that submits a written request and has a reliability-related need within 90 calendar days of receipt of such request or within 90 calendar days of completion of the benchmark GMD Vulnerability Assessment, whichever is later, as specified in Requirement R4. Each responsible entity, as determined in Requirement R1, shall also provide evidence, such as email notices or postal receipts showing recipient and date, that it has provided a documented response to comments received on its benchmark GMD Vulnerability Assessment within 90 calendar days of receipt of those comments in accordance with Requirement R4.
- R5. Each responsible entity, as determined in Requirement R1, shall provide GIC flow information to be used for the ~~transformer~~ benchmark thermal impact assessment of transformers specified in Requirement R6 to each Transmission Owner and Generator Owner that owns an applicable Bulk Electric System (BES) power transformer in the planning area. The GIC flow information shall include: *[Violation Risk Factor: Medium]*  
*[Time Horizon: Long-term Planning]*

- 5.1. The maximum effective GIC value for the worst case geoelectric field orientation for the benchmark GMD event described in Attachment 1. This value shall be provided to the Transmission Owner or Generator Owner that owns each applicable BES power transformer in the planning area.
  - 5.2. The effective GIC time series, GIC(t), calculated using the benchmark GMD event described in Attachment 1 in response to a written request from the Transmission Owner or Generator Owner that owns an applicable BES power transformer in the planning area. GIC(t) shall be provided within 90 calendar days of receipt of the written request and after determination of the maximum effective GIC value in Part 5.1.
- M5.** ~~M5.~~ Each responsible entity, as determined in Requirement R1, shall provide evidence, such as email records, web postings with an electronic notice of posting, or postal receipts showing recipient and date, that it has provided the maximum effective GIC ~~value~~values to the Transmission Owner and Generator Owner that owns each applicable BES power transformer in the planning area as specified in Requirement R5, Part 5.1. Each responsible entity, as determined in Requirement R1, shall also provide evidence, such as email records, web postings with an electronic notice of posting, or postal receipts showing recipient and date, that it has provided GIC(t) in response to a written request from the Transmission Owner or Generator Owner that owns an applicable BES power transformer in the planning area.
- R6.** Each Transmission Owner and Generator Owner shall conduct a benchmark thermal impact assessment for its solely and jointly owned applicable BES power transformers where the maximum effective GIC value provided in Requirement R5, Part 5.1, is 75 A per phase or greater. The benchmark thermal impact assessment shall: *[Violation Risk Factor: Medium] [Time Horizon: Long-term Planning]*
- 6.1. Be based on the effective GIC flow information provided in Requirement R5;
  - 6.2. Document assumptions used in the analysis;
  - 6.3. Describe suggested actions and supporting analysis to mitigate the impact of GICs, if any; and
  - 6.4. Be performed and provided to the responsible entities, as determined in Requirement R1, within 24 calendar months of receiving GIC flow information specified in Requirement R5, Part 5.1.
- M6.** ~~M6.~~ Each Transmission Owner and Generator Owner shall have evidence such as electronic or hard copies of its benchmark thermal impact assessment for all of its solely and jointly owned applicable BES power transformers where the maximum effective GIC value provided in Requirement R5, Part 5.1, is 75 A per phase or greater, and shall have evidence such as email records, web postings with an electronic notice of posting, or postal receipts showing recipient and date, that it has provided its thermal impact assessment to the responsible entities as specified in Requirement R6.

Rationale for Requirement R7: The proposed requirement addresses directives in Order No. 830 for establishing Corrective Action Plan (CAP) deadlines associated with GMD Vulnerability Assessments. In Order No. 830, FERC directed revisions to TPL-007 such that CAPs are developed within one year from the completion of GMD Vulnerability Assessments (P 101). Furthermore, FERC directed establishment of implementation deadlines after the completion of the CAP as follows (P 102):

- Two years for non-hardware mitigation; and
- Four years for hardware mitigation.

The objective of Part 7.4 is to provide awareness to potentially impacted entities when implementation of planned mitigation is not achievable within the deadlines established in Part 7.3. Examples of situations beyond the control of the of the responsible entity (see Section 7.4) include, but are not limited to:

- Delays resulting from regulatory/legal processes, such as permitting;
- Delays resulting from stakeholder processes required by tariff;
- Delays resulting from equipment lead times; or
- Delays resulting from the inability to acquire necessary Right-of-Way.

**R7.** Each responsible entity, as determined in Requirement R1, that concludes, through the benchmark GMD Vulnerability Assessment conducted in Requirement R4, that their System does not meet the performance requirements ~~off for the steady state~~ planning benchmark GMD event contained in Table 1, shall develop a Corrective Action Plan (CAP) addressing how the performance requirements will be met. The ~~Corrective Action Plan~~ CAP shall: [*Violation Risk Factor: High*] [*Time Horizon: Long-term Planning*]

**7.1.** List System deficiencies and the associated actions needed to achieve required System performance. Examples of such actions include:

- Installation, modification, retirement, or removal of Transmission and generation Facilities and any associated equipment.
- Installation, modification, or removal of Protection Systems or ~~Special Protection Systems.~~ Remedial Action Schemes.
- Use of Operating Procedures, specifying how long they will be needed as part of the ~~Corrective Action Plan.~~ CAP.
- Use of Demand-Side Management, new technologies, or other initiatives.

**7.2.** Be ~~reviewed in subsequent~~ developed within one year of completion of the benchmark GMD Vulnerability ~~Assessments until it is~~ Assessment.

**7.3.** Include a timetable, subject to revision by the responsible entity in Part 7.4, for implementing the selected actions from Part 7.1. The timetable shall:



7.3.1. Specify implementation of non-hardware mitigation, if any, within two years of development of the CAP; and

7.3.2. Specify implementation of hardware mitigation, if any, within four years of development of the CAP.

~~7.2.7.4.~~ Be revised if situations beyond the control of the responsible entity determined that the System meets the performance requirements contained in Table 1. Requirement R1 prevent implementation of the CAP within the timetable for implementation provided in Part 7.3. The revised CAP shall document the following, and be updated at least once every 12 calendar months until implemented:

7.4.1. Circumstances causing the delay for fully or partially implementing the selected actions in Part 7.1;

7.4.2. Description of the original CAP, and any previous changes to the CAP, with the associated timetable(s) for implementing the selected actions in Part 7.1; and

7.4.3. Revisions to the selected actions in Part 7.1, if any, including utilization of Operating Procedures if applicable, and the updated timetable for implementing the selected actions.

~~7.3.7.5.~~ Be provided within 90 calendar days of completion: (i) to the responsible entity's Reliability Coordinator, adjacent Planning Coordinator(s), adjacent Transmission Planner(s), and functional entities referenced in the Corrective Action Plan, and CAP within 90 calendar days of development or revision, and (ii) to any functional entity that submits a written request and has a reliability-related need within 90 calendar days of receipt of such request or within 90 calendar days of development or revision, whichever is later.

~~7.3.1.7.5.1.~~ If a recipient of the Corrective Action Plan CAP provides documented comments on the results, the responsible entity shall provide a documented response to that recipient within 90 calendar days of receipt of those comments.

**M7.** ~~M7.~~ Each responsible entity, as determined in Requirement R1, that concludes, through the benchmark GMD Vulnerability Assessment conducted in Requirement R4, that the responsible entity's System does not meet the performance requirements ~~of~~ for the steady state planning benchmark GMD event contained in Table 1 shall have evidence such as dated electronic or hard copies of its ~~Corrective Action Plan~~ CAP including timetable for implementing selected actions, as specified in Requirement R7. Each responsible entity, as determined in Requirement R1, shall also provide evidence, such as email records or postal receipts showing recipient and date, that it has revised its CAP if situations beyond the responsible entity's control prevent implementation of the CAP within the timetable specified. Each responsible entity, as determined in Requirement R1, shall also provide evidence, such as email records,

web postings with an electronic notice of posting, or postal receipts showing recipient and date, that it has distributed its ~~Corrective Action Plan~~CAP or relevant information, if any, ~~within 90 calendar days of its completion(i)~~ to ~~its~~the responsible entity's Reliability Coordinator, adjacent Planning Coordinator(s), adjacent Transmission Planner(s), ~~and~~ functional ~~entity~~entities referenced in the ~~Corrective Action Plan,~~ ~~and~~CAP ~~within 90 calendar days of development or revision, and (ii) to~~ any functional entity that submits a written request and has a reliability-related need; within 90 calendar days of receipt of such request or within 90 calendar days of development or revision, whichever is later as specified in Requirement R7. Each responsible entity, as determined in Requirement R1, shall also provide evidence, such as email notices or postal receipts showing recipient and date, that it has provided a documented response to comments received on its ~~Corrective Action Plan~~CAP within 90 calendar days of receipt of those comments, in accordance with Requirement R7.

**Supplemental GMD Vulnerability Assessment(s)**

Table 1—Steady-State Planning Events				
<p><b>Steady State:</b></p> <p><del>a. Voltage collapse, Cascading and uncontrolled islanding shall not occur.</del></p> <p><del>b. Generation loss is acceptable as a consequence of the planning event.</del></p> <p><del>c. Planned System adjustments such as Transmission configuration changes and re-dispatch of generation are allowed if they are executable within the time duration applicable to the Facility Ratings.</del></p>				
Category	Initial Condition	Event	Interruption of Firm Transmission Service Allowed	Load
<p><b>GMD</b></p> <p>GMD Event with Outages</p>	<p>1. System as may be postured in response to space weather information<sup>1</sup>, and then</p> <p>2. GMD event<sup>2</sup></p>	<p>Reactive Power compensation devices and other Transmission Facilities removed as a result of Protection System operation or Misoperation due to harmonics during the GMD event</p>	<p>Yes<sup>3</sup></p>	

Table 1—Steady-State Performance Footnotes	
<p>1. The System condition for GMD planning may include adjustments to posture the System that are executable in response to space weather information.</p>	<p>2. The GMD conditions for the planning event are described in Attachment 1 (Benchmark GMD Event).</p>

~~Load loss as a result of manual or automatic Load shedding (e.g. UVLS) and/or curtailment of Firm Transmission Service may be used to meet BES performance requirements during studied GMD conditions. The likelihood and magnitude of Load loss or curtailment of Firm Transmission Service should be minimized.~~ **Rationale for Requirements R8 – R10:** The proposed requirements address directives in Order No. 830 for revising the benchmark GMD event used in GMD Vulnerability Assessments (P 44, P 47-49). The requirements add a supplemental GMD Vulnerability Assessment based on the supplemental GMD event that accounts for localized peak geoelectric fields.

- R8.** Each responsible entity, as determined in Requirement R1, shall complete a supplemental GMD Vulnerability Assessment of the Near-Term Transmission Planning Horizon at least once every 60 calendar months. This supplemental GMD Vulnerability Assessment shall use a study or studies based on models identified in Requirement R2, document assumptions, and document summarized results of the steady state analysis. [Violation Risk Factor: High] [Time Horizon: Long-term Planning]
- 8.1.** The study or studies shall include the following conditions:
- 8.1.1.** System On-Peak Load for at least one year within the Near-Term Transmission Planning Horizon; and
  - 8.1.2.** System Off-Peak Load for at least one year within the Near-Term Transmission Planning Horizon.
- 8.2.** The study or studies shall be conducted based on the supplemental GMD event described in Attachment 1 to determine whether the System meets the performance requirements for the steady state planning supplemental GMD event contained in Table 1.
- 8.3.** If the analysis concludes there is Cascading caused by the supplemental GMD event described in Attachment 1, an evaluation of possible actions designed to reduce the likelihood or mitigate the consequences and adverse impacts of the event(s) shall be conducted.
- 8.4.** The supplemental GMD Vulnerability Assessment shall be provided: (i) to the responsible entity's Reliability Coordinator, adjacent Planning Coordinators, adjacent Transmission Planners within 90 calendar days of completion, and (ii) to any functional entity that submits a written request and has a reliability-related need within 90 calendar days of receipt of such request or within 90 calendar days of completion of the supplemental GMD Vulnerability Assessment, whichever is later.
- 8.4.1.** If a recipient of the supplemental GMD Vulnerability Assessment provides documented comments on the results, the responsible entity shall provide a documented response to that recipient within 90 calendar days of receipt of those comments.

- M8. Each responsible entity, as determined in Requirement R1, shall have dated evidence such as electronic or hard copies of its supplemental GMD Vulnerability Assessment meeting all of the requirements in Requirement R8. Each responsible entity, as determined in Requirement R1, shall also provide evidence, such as email records, web postings with an electronic notice of posting, or postal receipts showing recipient and date, that it has distributed its supplemental GMD Vulnerability: (i) to the responsible entity's Reliability Coordinator, adjacent Planning Coordinators, adjacent Transmission Planners within 90 calendar days of completion, and (ii) to any functional entity that submits a written request and has a reliability-related need within 90 calendar days of receipt of such request or within 90 calendar days of completion of the supplemental GMD Vulnerability Assessment, whichever is later, as specified in Requirement R8. Each responsible entity, as determined in Requirement R1, shall also provide evidence, such as email notices or postal receipts showing recipient and date, that it has provided a documented response to comments received on its supplemental GMD Vulnerability Assessment within 90 calendar days of receipt of those comments in accordance with Requirement R8.
- R9. Each responsible entity, as determined in Requirement R1, shall provide GIC flow information to be used for the supplemental thermal impact assessment of transformers specified in Requirement R10 to each Transmission Owner and Generator Owner that owns an applicable Bulk Electric System (BES) power transformer in the planning area. The GIC flow information shall include: *[Violation Risk Factor: Medium] [Time Horizon: Long-term Planning]*
- 9.1. The maximum effective GIC value for the worst case geoelectric field orientation for the supplemental GMD event described in Attachment 1. This value shall be provided to the Transmission Owner or Generator Owner that owns each applicable BES power transformer in the planning area.
- 9.2. The effective GIC time series, GIC(t), calculated using the supplemental GMD event described in Attachment 1 in response to a written request from the Transmission Owner or Generator Owner that owns an applicable BES power transformer in the planning area. GIC(t) shall be provided within 90 calendar days of receipt of the written request and after determination of the maximum effective GIC value in Part 9.1.
- M9. Each responsible entity, as determined in Requirement R1, shall provide evidence, such as email records, web postings with an electronic notice of posting, or postal receipts showing recipient and date, that it has provided the maximum effective GIC values to the Transmission Owner and Generator Owner that owns each applicable BES power transformer in the planning area as specified in Requirement R9, Part 9.1. Each responsible entity, as determined in Requirement R1, shall also provide evidence, such as email records, web postings with an electronic notice of posting, or postal receipts showing recipient and date, that it has provided GIC(t) in response to a written request from the Transmission Owner or Generator Owner that owns an applicable BES power transformer in the planning area.

**R10.** Each Transmission Owner and Generator Owner shall conduct a supplemental thermal impact assessment for its solely and jointly owned applicable BES power transformers where the maximum effective GIC value provided in Requirement R9, Part 9.1, is 85 A per phase or greater. The supplemental thermal impact assessment shall: [Violation Risk Factor: Medium] [Time Horizon: Long-term Planning]

**10.1.** Be based on the effective GIC flow information provided in Requirement R9;

**10.2.** Document assumptions used in the analysis;

**10.3.** Describe suggested actions and supporting analysis to mitigate the impact of GICs, if any; and

**10.4.** Be performed and provided to the responsible entities, as determined in Requirement R1, within 24 calendar months of receiving GIC flow information specified in Requirement R9, Part 9.1.

**M10.** Each Transmission Owner and Generator Owner shall have evidence such as electronic or hard copies of its supplemental thermal impact assessment for all of its solely and jointly owned applicable BES power transformers where the maximum effective GIC value provided in Requirement R9, Part 9.1, is 85 A per phase or greater, and shall have evidence such as email records, web postings with an electronic notice of posting, or postal receipts showing recipient and date, that it has provided its supplemental thermal impact assessment to the responsible entities as specified in Requirement R10.

### **GMD Measurement Data Processes**

**Rationale for Requirements R11 and R12:** The proposed requirements address directives in Order No. 830 for requiring responsible entities to collect GIC monitoring and magnetometer data as necessary to enable model validation and situational awareness (P 88; P. 90-92). GMD measurement data refers to GIC monitor data and geomagnetic field data in Requirements R11 and R12, respectively. See the Guidelines and Technical Basis section of this standard for technical information.

The objective of Requirement R11 is for entities to obtain GIC data for the Planning Coordinator's planning area or other part of the system included in the Planning Coordinator's GIC System model to inform GMD Vulnerability Assessments. Technical considerations for GIC monitoring are contained in Chapter 9 of the 2012 *Special Reliability Assessment Interim Report: Effects of Geomagnetic Disturbances on the Bulk-Power System* (NERC 2012 GMD Report). GIC monitoring is generally performed by Hall effect transducers that are attached to the neutral of the transformer and measure dc current flowing through the neutral.

The objective of Requirement R12 is for entities to obtain geomagnetic field data for the Planning Coordinator's planning area to inform GMD Vulnerability Assessments. Magnetometers provide geomagnetic field data by measuring changes in the earth's magnetic field. Sources of geomagnetic field data include:

- Observatories such as those operated by U.S. Geological Survey, Natural Resources Canada, research organizations, or university research facilities;
- Installed magnetometers; and
- Commercial or third-party sources of geomagnetic field data.

Geomagnetic field data for a Planning Coordinator's planning area is obtained from one or more of the above data sources located in the Planning Coordinator's planning area, or by obtaining a geomagnetic field data product for the Planning Coordinator's planning area from a government or research organization. The geomagnetic field data product does not need to be derived from a magnetometer or observatory within the Planning Coordinator's planning area.

**R11.** Each responsible entity, as determined in Requirement R1, shall implement a process to obtain GIC monitor data from at least one GIC monitor located in the Planning Coordinator's planning area or other part of the system included in the Planning Coordinator's GIC System model. *[Violation Risk Factor: Lower] [Time Horizon: Long-term Planning]*

**M11.** Each responsible entity, as determined in Requirement R1, shall have evidence such as electronic or hard copies of its GIC monitor location(s) and documentation of its process to obtain GIC monitor data in accordance with Requirement R11.

**R12.** Each responsible entity, as determined in Requirement R1, shall implement a process to obtain geomagnetic field data for its Planning Coordinator's planning area. *[Violation Risk Factor: Lower] [Time Horizon: Long-term Planning]*

**M12.** Each responsible entity, as determined in Requirement R1, shall have evidence such as electronic or hard copies of its process to obtain geomagnetic field data for its Planning Coordinator's planning area in accordance with Requirement R12.

## **C. Compliance**

### **1. Compliance Monitoring Process**

**1.1. Compliance Enforcement Authority:** "Compliance Enforcement Authority" means NERC or the Regional Entity, or any entity as otherwise designated by an Applicable Governmental Authority, in their respective roles of monitoring and/or enforcing compliance with mandatory and enforceable Reliability Standards in their respective jurisdictions.

**1.2. Evidence Retention:** The following evidence retention period(s) identify the period of time an entity is required to retain specific evidence to demonstrate compliance. For instances where the evidence retention period specified below

is shorter than the time since the last audit, the Compliance Enforcement Authority may ask an entity to provide other evidence to show that it was compliant for the full-time period since the last audit.

The applicable entity shall keep data or evidence to show compliance as identified below unless directed by its Compliance Enforcement Authority to retain specific evidence for a longer period of time as part of an investigation.

- For Requirements R1, R2, R3, R5, R6, R9, and R10, each responsible entity shall retain documentation as evidence for five years.
- For Requirements R4 and R8, each responsible entity shall retain documentation of the current GMD Vulnerability Assessment and the preceding GMD Vulnerability Assessment.
- For Requirement R7, each responsible entity shall retain documentation as evidence for five years or until all actions in the Corrective Action Plan are completed, whichever is later.
- For Requirements R11 and R12, each responsible entity shall retain documentation as evidence for three years.

**1.3. Compliance Monitoring and Enforcement Program:** As defined in the NERC Rules of Procedure, “Compliance Monitoring and Enforcement Program” refers to the identification of the processes that will be used to evaluate data or information for the purpose of assessing performance or outcomes with the associated Reliability Standard.

**Table 1: Steady State Planning GMD Event**

**Steady State:**

- a. Voltage collapse, Cascading and uncontrolled islanding shall not occur.
- b. Generation loss is acceptable as a consequence of the steady state planning GMD events.
- c. Planned System adjustments such as Transmission configuration changes and re-dispatch of generation are allowed if such adjustments are executable within the time duration applicable to the Facility Ratings.

<u>Category</u>	<u>Initial Condition</u>	<u>Event</u>	<u>Interruption of Firm Transmission Service Allowed</u>	<u>Load Loss Allowed</u>
<u>Benchmark GMD Event - GMD Event with Outages</u>	<u>1. System as may be postured in response to space weather information<sup>1</sup>, and then 2. GMD event<sup>2</sup></u>	<u>Reactive Power compensation devices and other Transmission Facilities removed as a result of Protection System operation or Misoperation due to harmonics during the GMD event</u>	<u>Yes<sup>3</sup></u>	<u>Yes<sup>3</sup></u>
<u>Supplemental GMD Event - GMD Event with Outages</u>	<u>1. System as may be postured in response to space weather information<sup>1</sup>, and then 2. GMD event<sup>2</sup></u>	<u>Reactive Power compensation devices and other Transmission Facilities removed as a result of Protection System operation or Misoperation due to harmonics during the GMD event</u>	<u>Yes</u>	<u>Yes</u>

**Table 1: Steady State Performance Footnotes**

- 1. The System condition for GMD planning may include adjustments to posture the System that are executable in response to space weather information.
- 2. The GMD conditions for the benchmark and supplemental planning events are described in Attachment 1.
- 3. Load loss as a result of manual or automatic Load shedding (e.g., UVLS) and/or curtailment of Firm Transmission Service may be used to meet BES performance requirements during studied GMD conditions. The likelihood and magnitude of Load loss or curtailment of Firm Transmission Service should be minimized.



### Violation Severity Levels

R #	Violation Severity Levels			
	Lower VSL	Moderate VSL	High VSL	Severe VSL
<u>R1.</u>	<u>N/A</u>	<u>N/A</u>	<u>N/A</u>	<u>The Planning Coordinator, in conjunction with its Transmission Planner(s), failed to determine and identify individual or joint responsibilities of the Planning Coordinator and Transmission Planner(s) in the Planning Coordinator’s planning area for maintaining models, performing the study or studies needed to complete benchmark and supplemental GMD Vulnerability Assessments, and implementing process(es) to obtain GMD measurement data as specified in this standard.</u>

<u>R #</u>	<u>Violation Severity Levels</u>			
	<u>Lower VSL</u>	<u>Moderate VSL</u>	<u>High VSL</u>	<u>Severe VSL</u>
<u>R2.</u>	<u>N/A</u>	<u>N/A</u>	<u>The responsible entity did not maintain either System models or GIC System models of the responsible entity’s planning area for performing the studies needed to complete benchmark and supplemental GMD Vulnerability Assessments.</u>	<u>The responsible entity did not maintain both System models and GIC System models of the responsible entity’s planning area for performing the studies needed to complete benchmark and supplemental GMD Vulnerability Assessments.</u>
<u>R3.</u>	<u>N/A</u>	<u>N/A</u>	<u>N/A</u>	<u>The responsible entity did not have criteria for acceptable System steady state voltage performance for its System during the GMD events described in Attachment 1 as required.</u>

<u>R #</u>	<u>Violation Severity Levels</u>			
	<u>Lower VSL</u>	<u>Moderate VSL</u>	<u>High VSL</u>	<u>Severe VSL</u>
<u>R4.</u>	<p><u>The responsible entity completed a benchmark GMD Vulnerability Assessment, but it was more than 60 calendar months and less than or equal to 64 calendar months since the last benchmark GMD Vulnerability Assessment.</u></p>	<p><u>The responsible entity's completed benchmark GMD Vulnerability Assessment failed to satisfy one of the elements listed in Requirement R4, Parts 4.1 through 4.3;</u>  <u>OR</u>  <u>The responsible entity completed a benchmark GMD Vulnerability Assessment, but it was more than 64 calendar months and less than or equal to 68 calendar months since the last benchmark GMD Vulnerability Assessment.</u></p>	<p><u>The responsible entity's completed benchmark GMD Vulnerability Assessment failed to satisfy two of the elements listed in Requirement R4, Parts 4.1 through 4.3;</u>  <u>OR</u>  <u>The responsible entity completed a benchmark GMD Vulnerability Assessment, but it was more than 68 calendar months and less than or equal to 72 calendar months since the last benchmark GMD Vulnerability Assessment.</u></p>	<p><u>The responsible entity's completed benchmark GMD Vulnerability Assessment failed to satisfy three of the elements listed in Requirement R4, Parts 4.1 through 4.3;</u>  <u>OR</u>  <u>The responsible entity completed a benchmark GMD Vulnerability Assessment, but it was more than 72 calendar months since the last benchmark GMD Vulnerability Assessment;</u>  <u>OR</u>  <u>The responsible entity does not have a completed benchmark GMD Vulnerability Assessment.</u></p>

<u>R #</u>	<u>Violation Severity Levels</u>			
	<u>Lower VSL</u>	<u>Moderate VSL</u>	<u>High VSL</u>	<u>Severe VSL</u>
<u>R5.</u>	<u>The responsible entity provided the effective GIC time series, GIC(t), in response to written request, but did so more than 90 calendar days and less than or equal to 100 calendar days after receipt of a written request.</u>	<u>The responsible entity provided the effective GIC time series, GIC(t), in response to written request, but did so more than 100 calendar days and less than or equal to 110 calendar days after receipt of a written request.</u>	<u>The responsible entity provided the effective GIC time series, GIC(t), in response to written request, but did so more than 110 calendar days after receipt of a written request.</u>	<u>The responsible entity did not provide the maximum effective GIC value to the Transmission Owner and Generator Owner that owns each applicable BES power transformer in the planning area;</u> <u>OR</u> <u>The responsible entity did not provide the effective GIC time series, GIC(t), upon written request.</u>

<p><b>R6.</b></p>	<p><u>The responsible entity failed to conduct a benchmark thermal impact assessment for 5% or less or one of its solely owned and jointly owned applicable BES power transformers (whichever is greater) where the maximum effective GIC value provided in Requirement R5, Part 5.1, is 75 A or greater per phase;</u>  <u>OR</u>  <u>The responsible entity conducted a benchmark thermal impact assessment for its solely owned and jointly owned applicable BES power transformers where the maximum effective GIC value provided in Requirement R5, Part 5.1, is 75 A or greater per phase but did so more than 24 calendar months and less than or equal to 26 calendar months of receiving GIC flow information specified in Requirement R5, Part 5.1.</u></p>	<p><u>The responsible entity failed to conduct a benchmark thermal impact assessment for more than 5% up to (and including) 10% or two of its solely owned and jointly owned applicable BES power transformers (whichever is greater) where the maximum effective GIC value provided in Requirement R5, Part 5.1, is 75 A or greater per phase;</u>  <u>OR</u>  <u>The responsible entity conducted a benchmark thermal impact assessment for its solely owned and jointly owned applicable BES power transformers where the maximum effective GIC value provided in Requirement R5, Part 5.1, is 75 A or greater per phase but did so more than 26 calendar months and less than or equal to 28 calendar months of receiving GIC flow information specified in Requirement R5, Part 5.1;</u></p>	<p><u>The responsible entity failed to conduct a benchmark thermal impact assessment for more than 10% up to (and including) 15% or three of its solely owned and jointly owned applicable BES power transformers (whichever is greater) where the maximum effective GIC value provided in Requirement R5, Part 5.1, is 75 A or greater per phase;</u>  <u>OR</u>  <u>The responsible entity conducted a benchmark thermal impact assessment for its solely owned and jointly owned applicable BES power transformers where the maximum effective GIC value provided in Requirement R5, Part 5.1, is 75 A or greater per phase but did so more than 28 calendar months and less than or equal to 30 calendar months of receiving GIC flow information specified in Requirement R5, Part 5.1;</u></p>	<p><u>The responsible entity failed to conduct a benchmark thermal impact assessment for more than 15% or more than three of its solely owned and jointly owned applicable BES power transformers (whichever is greater) where the maximum effective GIC value provided in Requirement R5, Part 5.1, is 75 A or greater per phase;</u>  <u>OR</u>  <u>The responsible entity conducted a benchmark thermal impact assessment for its solely owned and jointly owned applicable BES power transformers where the maximum effective GIC value provided in Requirement R5, Part 5.1, is 75 A or greater per phase but did so more than 30 calendar months of receiving GIC flow information specified in Requirement R5, Part 5.1;</u>  <u>OR</u></p>
-------------------	---	---	--	--

<u>R #</u>	<u>Violation Severity Levels</u>			
	<u>Lower VSL</u>	<u>Moderate VSL</u>	<u>High VSL</u>	<u>Severe VSL</u>
		<p><u>OR</u></p> <p><u>The responsible entity failed to include one of the required elements as listed in Requirement R6, Parts 6.1 through 6.3.</u></p>	<p><u>OR</u></p> <p><u>The responsible entity failed to include two of the required elements as listed in Requirement R6, Parts 6.1 through 6.3.</u></p>	<p><u>The responsible entity failed to include three of the required elements as listed in Requirement R6, Parts 6.1 through 6.3.</u></p>
<u>R7.</u>	<p><u>The responsible entity's Corrective Action Plan failed to comply with one of the elements in Requirement R7, Parts 7.1 through 7.5.</u></p>	<p><u>The responsible entity's Corrective Action Plan failed to comply with two of the elements in Requirement R7, Parts 7.1 through 7.5.</u></p>	<p><u>The responsible entity's Corrective Action Plan failed to comply with three of the elements in Requirement R7, Parts 7.1 through 7.5.</u></p>	<p><u>The responsible entity's Corrective Action Plan failed to comply with four or more of the elements in Requirement R7, Parts 7.1 through 7.5;</u></p> <p><u>OR</u></p> <p><u>The responsible entity did not have a Corrective Action Plan as required by Requirement R7.</u></p>

R #	Violation Severity Levels			
	Lower VSL	Moderate VSL	High VSL	Severe VSL
R8.	<p><u>The responsible entity's completed supplemental GMD Vulnerability Assessment failed to satisfy one of elements listed in Requirement R8, Parts 8.1 through 8.4;</u></p> <p><u>OR</u></p> <p><u>The responsible entity completed a supplemental GMD Vulnerability Assessment, but it was more than 60 calendar months and less than or equal to 64 calendar months since the last supplemental GMD Vulnerability Assessment.</u></p>	<p><u>The responsible entity's completed supplemental GMD Vulnerability Assessment failed to satisfy two of elements listed in Requirement R8, Parts 8.1 through 8.4;</u></p> <p><u>OR</u></p> <p><u>The responsible entity completed a supplemental GMD Vulnerability Assessment, but it was more than 64 calendar months and less than or equal to 68 calendar months since the last supplemental GMD Vulnerability Assessment.</u></p>	<p><u>The responsible entity's completed supplemental GMD Vulnerability Assessment failed to satisfy three of the elements listed in Requirement R8, Parts 8.1 through 8.4;</u></p> <p><u>OR</u></p> <p><u>The responsible entity completed a supplemental GMD Vulnerability Assessment, but it was more than 68 calendar months and less than or equal to 72 calendar months since the last supplemental GMD Vulnerability Assessment.</u></p>	<p><u>The responsible entity's completed supplemental GMD Vulnerability Assessment failed to satisfy four of the elements listed in Requirement R8, Parts 8.1 through 8.4;</u></p> <p><u>OR</u></p> <p><u>The responsible entity completed a supplemental GMD Vulnerability Assessment, but it was more than 72 calendar months since the last supplemental GMD Vulnerability Assessment;</u></p> <p><u>OR</u></p> <p><u>The responsible entity does not have a completed supplemental GMD Vulnerability Assessment.</u></p>

<u>R #</u>	<u>Violation Severity Levels</u>			
	<u>Lower VSL</u>	<u>Moderate VSL</u>	<u>High VSL</u>	<u>Severe VSL</u>
<u>R9.</u>	<u>The responsible entity provided the effective GIC time series, GIC(t), in response to written request, but did so more than 90 calendar days and less than or equal to 100 calendar days after receipt of a written request.</u>	<u>The responsible entity provided the effective GIC time series, GIC(t), in response to written request, but did so more than 100 calendar days and less than or equal to 110 calendar days after receipt of a written request.</u>	<u>The responsible entity provided the effective GIC time series, GIC(t), in response to written request, but did so more than 110 calendar days after receipt of a written request.</u>	<u>The responsible entity did not provide the maximum effective GIC value to the Transmission Owner and Generator Owner that owns each applicable BES power transformer in the planning area;</u> <u>OR</u> <u>The responsible entity did not provide the effective GIC time series, GIC(t), upon written request.</u>



<p><b>R10.</b></p>	<p><u>The responsible entity failed to conduct a supplemental thermal impact assessment for 5% or less or one of its solely owned and jointly owned applicable BES power transformers (whichever is greater) where the maximum effective GIC value provided in Requirement R9, Part 9.1, is 85 A or greater per phase;</u> <u>OR</u> <u>The responsible entity conducted a supplemental thermal impact assessment for its solely owned and jointly owned applicable BES power transformers where the maximum effective GIC value provided in Requirement R9, Part 9.1, is 85 A or greater per phase but did so more than 24 calendar months and less than or equal to 26 calendar months of receiving GIC flow information specified in Requirement R9, Part 9.1.</u></p>	<p><u>The responsible entity failed to conduct a supplemental thermal impact assessment for more than 5% up to (and including) 10% or two of its solely owned and jointly owned applicable BES power transformers (whichever is greater) where the maximum effective GIC value provided in Requirement R9, Part 9.1, is 85 A or greater per phase;</u> <u>OR</u> <u>The responsible entity conducted a supplemental thermal impact assessment for its solely owned and jointly owned applicable BES power transformers where the maximum effective GIC value provided in Requirement R9, Part 9.1, is 85 A or greater per phase but did so more than 26 calendar months and less than or equal to 28 calendar months of receiving GIC flow information specified in Requirement R9, Part 9.1</u></p>	<p><u>The responsible entity failed to conduct a supplemental thermal impact assessment for more than 10% up to (and including) 15% or three of its solely owned and jointly owned applicable BES power transformers (whichever is greater) where the maximum effective GIC value provided in Requirement R9, Part 9.1, is 85 A or greater per phase;</u> <u>OR</u> <u>The responsible entity conducted a supplemental thermal impact assessment for its solely owned and jointly owned applicable BES power transformers where the maximum effective GIC value provided in Requirement R9, Part 9.1, is 85 A or greater per phase but did so more than 28 calendar months and less than or equal to 30 calendar months of receiving GIC flow information specified in Requirement R9, Part 9.1;</u></p>	<p><u>The responsible entity failed to conduct a supplemental thermal impact assessment for more than 15% or more than three of its solely owned and jointly owned applicable BES power transformers (whichever is greater) where the maximum effective GIC value provided in Requirement R9, Part 9.1, is 85 A or greater per phase;</u> <u>OR</u> <u>The responsible entity conducted a supplemental thermal impact assessment for its solely owned and jointly owned applicable BES power transformers where the maximum effective GIC value provided in Requirement R9, Part 9.1, is 85 A or greater per phase but did so more than 30 calendar months of receiving GIC flow information specified in Requirement R9, Part 9.1;</u> <u>OR</u></p>
--------------------	---	--	--	---

<u>R #</u>	<u>Violation Severity Levels</u>			
	<u>Lower VSL</u>	<u>Moderate VSL</u>	<u>High VSL</u>	<u>Severe VSL</u>
		<u>OR</u> <u>The responsible entity failed to include one of the required elements as listed in Requirement R10, Parts 10.1 through 10.3.</u>	<u>OR</u> <u>The responsible entity failed to include two of the required elements as listed in Requirement R10, Parts 10.1 through 10.3.</u>	<u>The responsible entity failed to include three of the required elements as listed in Requirement R10, Parts 10.1 through 10.3.</u>
<u>R11.</u>	<u>N/A</u>	<u>N/A</u>	<u>N/A</u>	<u>The responsible entity did not implement a process to obtain GIC monitor data from at least one GIC monitor located in the Planning Coordinator’s planning area or other part of the system included in the Planning Coordinator’s GIC System Model.</u>
<u>R12.</u>	<u>N/A</u>	<u>N/A</u>	<u>N/A</u>	<u>The responsible entity did not implement a process to obtain geomagnetic field data for its Planning Coordinator’s planning area.</u>

**D. Regional Variances**

None.

**E. Associated Documents**

Attachment 1

## Version History

<u>Version</u>	<u>Date</u>	<u>Action</u>	<u>Change Tracking</u>
<u>1</u>	<u>December 17, 2014</u>	<u>Adopted by the NERC Board of Trustees</u>	<u>New</u>
<u>2</u>	<u>TBD</u>	<u>Revised to respond to directives in FERC Order No. 830.</u>	<u>Revised</u>

## Attachment 1

### Calculating Goelectric Fields for the Benchmark and Supplemental GMD EventEvents

The benchmark GMD event<sup>1</sup> defines the goelectric field values used to compute GIC flows that are needed to conduct a benchmark GMD Vulnerability Assessment. It is composed of the following elements: (1) a reference peak goelectric field amplitude of 8 V/km derived from statistical analysis of historical magnetometer data; (2) scaling factors to account for local geomagnetic latitude; (3) scaling factors to account for local earth conductivity; and (4) a reference geomagnetic field time series or waveshape/waveform to facilitate time-domain analysis of GMD impact on equipment.

The supplemental GMD event is composed of similar elements as described above, except (1) the reference peak goelectric field amplitude is 12 V/km over a localized area; and (2) the geomagnetic field time series or waveform includes a local enhancement in the waveform.<sup>2</sup>

The regional goelectric field peak amplitude used in GMD Vulnerability Assessment,  $E_{peak}$ , can be obtained from the reference goelectric field value of 8 V/km for the benchmark GMD event (1) or 12 V/km for the supplemental GMD event (2) using the following relationshiprelationships:

$$E_{peak} = \frac{8 \times \alpha \times \beta_b}{(V/km)} \quad (1)$$

$$E_{peak} = \frac{12 \times \alpha \times \beta_s}{(V/km)} \quad (2)$$

where,  $\alpha$  is the scaling factor to account for local geomagnetic latitude, and  $\beta$  is a scaling factor to account for the local earth conductivity structure. Subscripts  $b$  and  $s$  for the  $\beta$  scaling factor denote association with the benchmark or supplemental GMD events, respectively.

#### Scaling the Geomagnetic Field

The benchmark and supplemental GMD event events are defined for geomagnetic latitude of 60° and ~~it~~ must be scaled to account for regional differences based on geomagnetic latitude. Table 2 provides a scaling factor correlating peak goelectric field to geomagnetic latitude. Alternatively, the scaling factor  $\alpha$  is computed with the empirical expression:

$$\alpha = \frac{1}{\cos(\theta)}$$

<sup>1</sup> The benchmark GMD event description is available on the Project 2013-03 Benchmark Geomagnetic Disturbance Event Description, May 2016 is available on the Related Information webpage for TPL-007-1: [http://www.nerc.com/pa/Stand/TPL0071RD/Benchmark\\_clean\\_May12\\_complete.pdf](http://www.nerc.com/pa/Stand/TPL0071RD/Benchmark_clean_May12_complete.pdf) Mitigation project page.

<sup>2</sup> The extent of local enhancements is on the order of 100 km in North-South (latitude) direction but longer in East-West (longitude) direction. The local enhancement in the geomagnetic field occurs over the time period of 2-5 minutes. Additional information is available in the Supplemental Geomagnetic Disturbance Event Description, October 2017 white paper on the Project 2013-03 Geomagnetic Disturbance Mitigation project webpage: <http://www.nerc.com/pa/Stand/Pages/Project-2013-03-Geomagnetic-Disturbance-Mitigation.aspx>.

$$\alpha = 0.001 \times e^{(0.115 \times L)} \tag{3}$$

where  $L$  is the geomagnetic latitude in degrees and  $0.1 \leq \alpha \leq 1$ .

For large planning areas that cover more than one scaling factor from Table 2, the GMD Vulnerability Assessment should be based on a peak geoelectric field that is:

- calculated by using the most conservative (largest) value for  $\alpha$ ; or
- calculated assuming a non-uniform or piecewise uniform geomagnetic field.

Table 2— <u>Geomagnetic Field Scaling Factors for the Benchmark and Supplemental GMD Events</u>	
Geomagnetic Latitude (Degrees)	Scaling Factor1 ( $\alpha$ )
$\leq 40$	0.10
45	0.2
50	0.3
54	0.5
56	0.6
57	0.7
58	0.8
59	0.9
$\geq 60$	1.0

### Scaling the Geoelectric Field

The benchmark GMD event is defined for the reference Quebec earth model described in Table 4. The peak geoelectric field,  $E_{peak}$ , used in a GMD Vulnerability Assessment may be obtained by either:

- Calculating the geoelectric field for the ground conductivity in the planning area and the reference geomagnetic field time series scaled according to geomagnetic latitude, using a procedure such as the plane wave method described in the NERC GMD Task Force GIC Application Guide;<sup>3</sup> or
- Using the earth conductivity scaling factor  $\beta$  from Table 3 that correlates to the ground conductivity map in Figure 1 or Figure 2. Along with the scaling factor  $\alpha$  from equation (23) or Table 2,  $\beta$  is applied to the reference geoelectric field using equation (1 or 2, as applicable) to obtain the regional geoelectric field peak amplitude  $E_{peak}$  to be used in GMD Vulnerability ~~Assessment~~ Assessments. When a ground conductivity model is not

<sup>3</sup> Available at the NERC GMD Task Force project webpage: [http://www.nerc.com/comm/PC/Pages/Geomagnetic-Disturbance-Task-Force-\(GMDTF\)-2013.aspx](http://www.nerc.com/comm/PC/Pages/Geomagnetic-Disturbance-Task-Force-(GMDTF)-2013.aspx)

available, the planning entity should use the largest  $\beta$  factor of adjacent physiographic regions or a technically justified value.

The earth models used to calculate Table 3 for the United States were obtained from publicly available information published on the U. S. Geological Survey website.<sup>4</sup> The models used to calculate Table 3 for Canada were obtained from Natural Resources Canada (NRCan) and reflect the average structure for large regions. A planner can also use specific earth model(s) with documented justification and the reference geomagnetic field time series to calculate the  $\beta$  factor(s) as follows:

$$\beta = E/8 \tag{3}$$

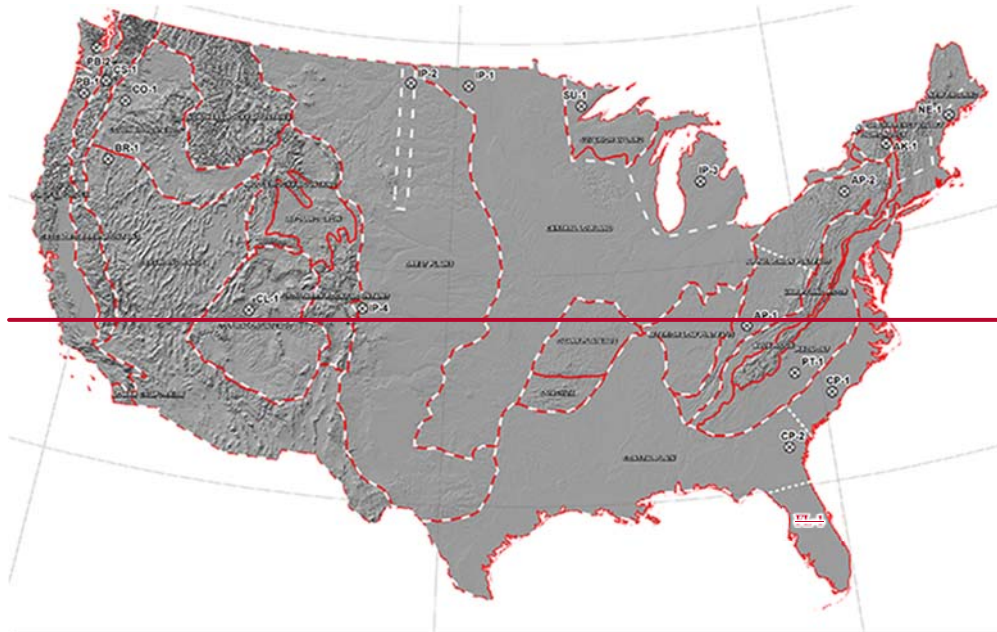
$$\beta_b = E/8 \text{ for the benchmark GMD event} \tag{4}$$

$$\beta_s = E/12 \text{ for the supplemental GMD} \tag{5}$$

where  $E$  is the absolute value of peak geoelectric in V/km obtained from the technically justified earth model and the reference geomagnetic field time series.

For large planning areas that span more than one  $\beta$  scaling factor, the most conservative (largest) value for  $\beta$  may be used in determining the peak geoelectric field to obtain conservative results. Alternatively, a planner could perform analysis using a non-uniform or piecewise uniform geoelectric field.

<sup>4</sup> Available at <http://geomag.usgs.gov/conductivity/>



**Applying the Localized Peak Goelectric Field in the Supplemental GMD Event**

The peak goelectric field of the supplemental GMD event occurs in a localized area.<sup>5</sup> Planners have flexibility to determine how to apply the localized peak goelectric field over the planning area in performing GIC calculations. Examples of approaches are:

- Apply the peak goelectric field (12 V/km scaled to the planning area) over the entire planning area;
- Apply a spatially limited (12 V/km scaled to the planning area) peak goelectric field (e.g., 100 km in North-South latitude direction and 500 km in East-West longitude direction) over a portion(s) of the system, and apply the benchmark GMD event over the rest of the system; or
- Other methods to adjust the benchmark GMD event analysis to account for the localized goelectric field enhancement of the supplemental GMD event.

**Figure 1: Physiographic Regions of the Continental United States<sup>6</sup>**

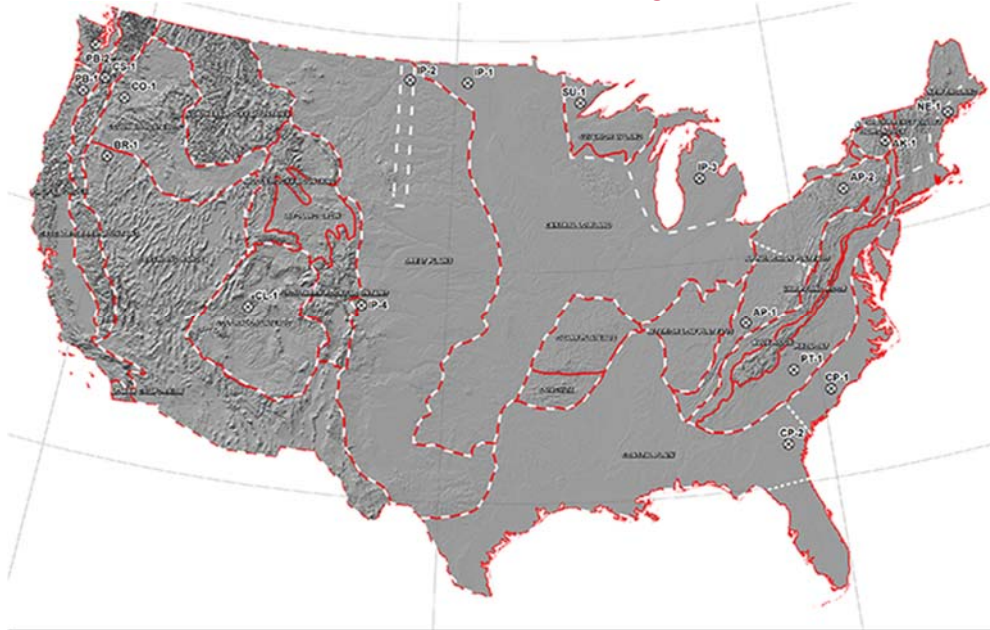
<sup>5</sup> See the Supplemental Geomagnetic Disturbance Description white paper located on the Project 2013-03 Geomagnetic Disturbance Mitigation project webpage: <http://www.nerc.com/pa/Stand/Pages/Project-2013-03-Geomagnetic-Disturbance-Mitigation.aspx>.

<sup>6</sup> Additional map detail is available at the U.S. Geological Survey: <http://geomag.usgs.gov/> (-).



Figure 2: Physiographic Regions of Canada

Table 3— Geoelectric Field Scaling Factors



USGS Earth-model	Scaling Factor ( $\beta$ )
AK1A	0.56
AK1B	0.56
AP1	0.33



AP2	0.82
BR1	0.22
CL1	0.76
CO1	0.27
CP1	0.81
CP2	0.95
FL1	0.74
CS1	0.41
IP1	0.94
IP2	0.28
IP3	0.93
IP4	0.41
NE1	0.81
PB1	0.62
PB2	0.46

PT1

**Figure 1: Physiographic Regions of the Continental United States<sup>7</sup>** 1.17

SL1	0.53
SU1	0.93
BOU	0.28
FBK	0.56
PRU	0.21
BC	0.67
PRAIRIES	0.96
SHIELD	1.0
ATLANTIC	0.79

<sup>7</sup> Additional map detail is available at the U.S. Geological Survey: <http://geomag.usgs.gov/> ().

Table 4— Reference Earth Model (Quebec)



Figure 2: Physiographic Regions of Canada

**Table 3: Geoelectric Field Scaling Factors**

<u>Earth model</u>	<u>Scaling Factor Benchmark Event (<math>\beta_b</math>)</u>	<u>Scaling Factor Supplemental Event (<math>\beta_s</math>)</u>
<u>AK1A</u>	<u>0.56</u>	<u>0.51</u>
<u>AK1B</u>	<u>0.56</u>	<u>0.51</u>
<u>AP1</u>	<u>0.33</u>	<u>0.30</u>
<u>AP2</u>	<u>0.82</u>	<u>0.78</u>
<u>BR1</u>	<u>0.22</u>	<u>0.22</u>
<u>CL1</u>	<u>0.76</u>	<u>0.73</u>
<u>CO1</u>	<u>0.27</u>	<u>0.25</u>
<u>CP1</u>	<u>0.81</u>	<u>0.77</u>
<u>CP2</u>	<u>0.95</u>	<u>0.86</u>
<u>FL1</u>	<u>0.76</u>	<u>0.73</u>
<u>CS1</u>	<u>0.41</u>	<u>0.37</u>
<u>IP1</u>	<u>0.94</u>	<u>0.90</u>

**Table 3: Geoelectric Field Scaling Factors**

<u>Earth model</u>	<u>Scaling Factor Benchmark Event (<math>\beta_b</math>)</u>	<u>Scaling Factor Supplemental Event (<math>\beta_s</math>)</u>
<u>IP2</u>	<u>0.28</u>	<u>0.25</u>
<u>IP3</u>	<u>0.93</u>	<u>0.90</u>
<u>IP4</u>	<u>0.41</u>	<u>0.35</u>
<u>NE1</u>	<u>0.81</u>	<u>0.77</u>
<u>PB1</u>	<u>0.62</u>	<u>0.55</u>
<u>PB2</u>	<u>0.46</u>	<u>0.39</u>
<u>PT1</u>	<u>1.17</u>	<u>1.19</u>
<u>SL1</u>	<u>0.53</u>	<u>0.49</u>
<u>SU1</u>	<u>0.93</u>	<u>0.90</u>
<u>BOU</u>	<u>0.28</u>	<u>0.24</u>
<u>FBK</u>	<u>0.56</u>	<u>0.56</u>
<u>PRU</u>	<u>0.21</u>	<u>0.22</u>
<u>BC</u>	<u>0.67</u>	<u>0.62</u>
<u>PRAIRIES</u>	<u>0.96</u>	<u>0.88</u>
<u>SHIELD</u>	<u>1.0</u>	<u>1.0</u>
<u>ATLANTIC</u>	<u>0.79</u>	<u>0.76</u>

**Rationale:** Scaling factors in Table 3 are dependent upon the frequency content of the reference storm. Consequently, the benchmark GMD event and the supplemental GMD event may produce different scaling factors for a given earth model.

The scaling factor associated with the benchmark GMD event for the Florida earth model (FL1) has been updated based on the earth model published on the USGS public website.

**Table 4: Reference Earth Model (Quebec)**

<b>Layer Thickness (km)</b>	<b>Resistivity (<math>\Omega</math>-m)</b>
15	20,000
10	200
125	1,000
200	100

$\infty$	3
----------	---

**Reference Geomagnetic Field Time Series or ~~Waveshape~~<sup>8</sup> Waveform for the Benchmark GMD Event<sup>9</sup>**

The geomagnetic field measurement record of the March 13-14 1989 GMD event, measured at ~~NRCan's~~<sup>the NRCan</sup> Ottawa geomagnetic observatory, is the basis for the reference geomagnetic field ~~waveshape~~<sup>waveform</sup> to be used to calculate the GIC time series, GIC(t), required for transformer thermal impact assessment.

The geomagnetic latitude of the Ottawa geomagnetic observatory is 55°; therefore, the ~~amplitude~~<sup>amplitudes</sup> of the geomagnetic field measurement data were scaled up to the 60° reference geomagnetic latitude (see Figure 3) such that the resulting peak geoelectric field amplitude computed using the reference earth model was 8 V/km (see Figures 4 and 5). ~~Sampling~~<sup>The sampling</sup> rate for the geomagnetic field ~~waveshape~~<sup>waveform</sup> is 10 seconds.<sup>10</sup> To use this geoelectric field time series when a different earth model is applicable, it should be scaled with the appropriate benchmark conductivity scaling factor  ~~$\beta$~~  <sup>$\beta_b$</sup> .

---

<sup>8</sup> Refer to the ~~Benchmark GMD Event Description~~ for details on the determination of the reference geomagnetic field ~~waveshape~~: [http://www.nerc.com/pa/Stand/Pages/Project\\_2013\\_03\\_Geomagnetic\\_Disturbance\\_Mitigation.aspx](http://www.nerc.com/pa/Stand/Pages/Project_2013_03_Geomagnetic_Disturbance_Mitigation.aspx)

<sup>9</sup> Refer to the Benchmark Geomagnetic Disturbance Event Description white paper for details on the determination of the reference geomagnetic field waveform: <http://www.nerc.com/pa/stand/Pages/TPL0071RI.aspx>.

<sup>10</sup> The data file of the benchmark geomagnetic field ~~waveshape~~<sup>waveform</sup> is available on the ~~NERC GMD Task Force project page~~<sup>Related Information webpage</sup> for TPL-007-1: <http://www.nerc.com/pa/stand/Pages/TPL0071RI.aspx>.

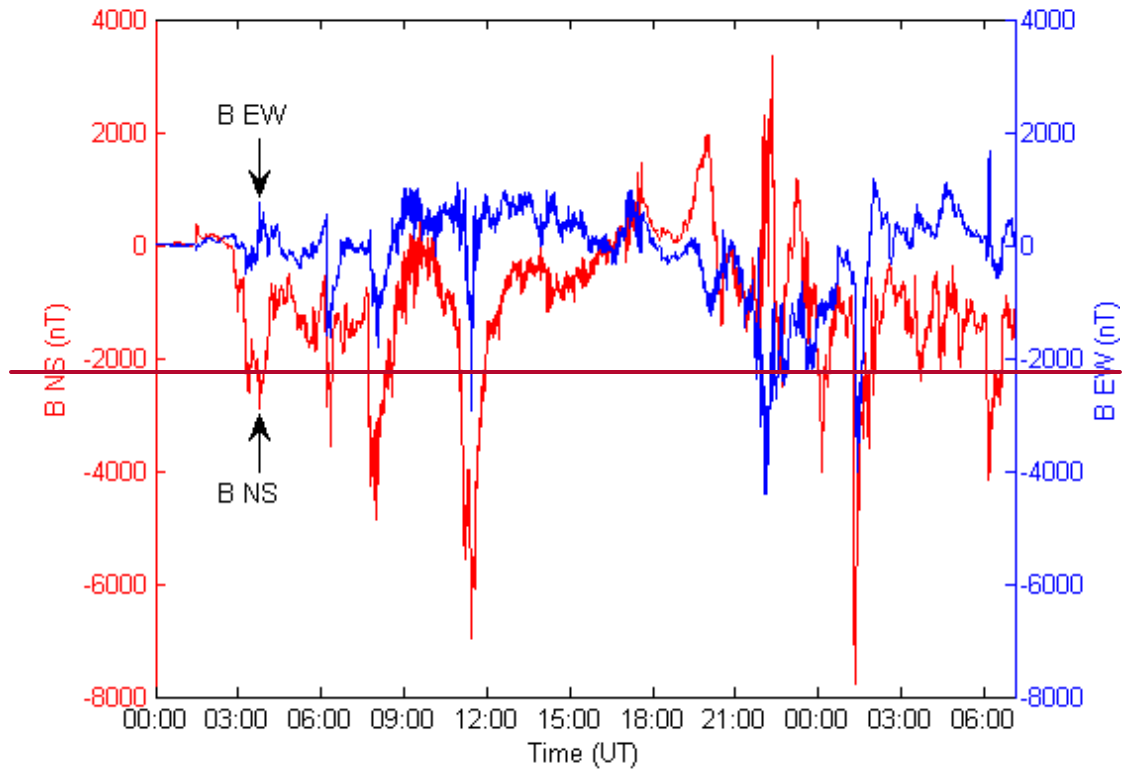


Figure 3: Benchmark Geomagnetic Field Waveshape. Red  $B_N$  (Northward), Blue  $B_E$  (Eastward)

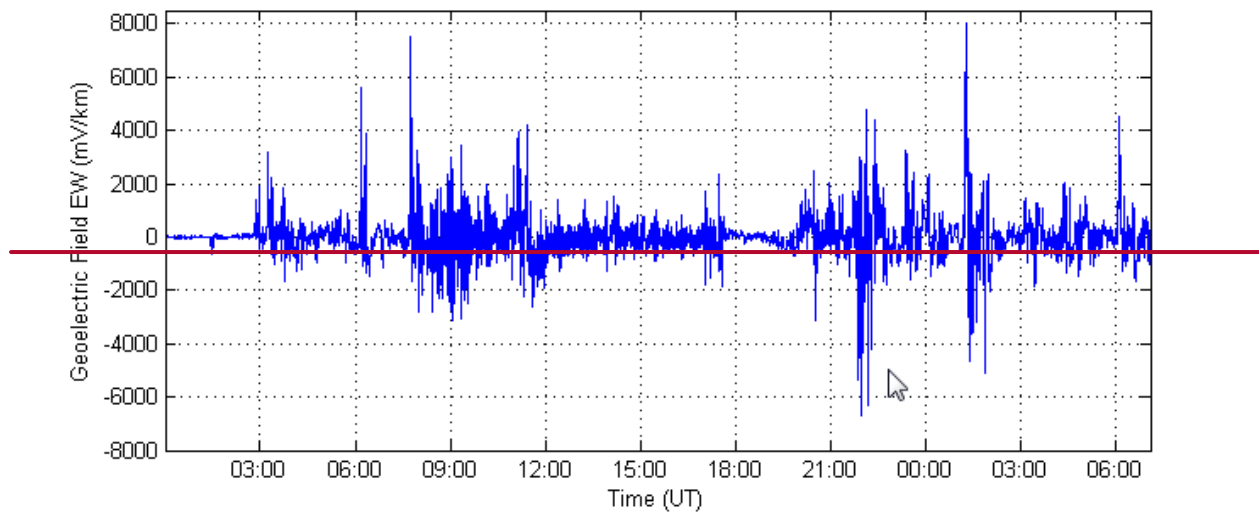
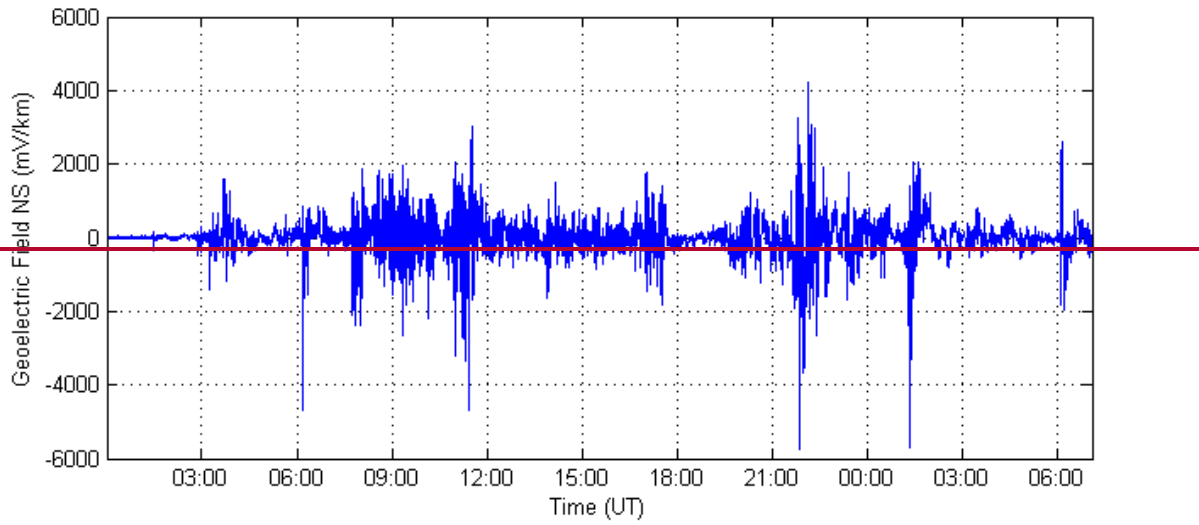


Figure 4: Benchmark Geoelectric Field Waveshape— $E_E$  (Eastward)



**Figure 5: Benchmark Geoelectric Field Waveshape —  $E_N$  (Northward)**

## ~~C.A.~~ **Compliance**

### ~~1.~~ **Compliance Monitoring Process**

#### ~~1.1.~~ **Compliance Enforcement Authority**

~~As defined in the NERC Rules of Procedure, “Compliance Enforcement Authority” means NERC or the Regional Entity in their respective roles of monitoring and enforcing compliance with the NERC Reliability Standards~~

#### ~~1.2.~~ **Evidence Retention**

~~The following evidence retention periods identify the period of time an entity is required to retain specific evidence to demonstrate compliance. For instances where the evidence retention period specified below is shorter than the time since the last audit, the CEA may ask an entity to provide other evidence to show that it was compliant for the full time period since the last audit.~~

~~The Planning Coordinator, Transmission Planner, Transmission Owner, and Generator Owner shall keep data or evidence to show compliance as identified below unless directed by its Compliance Enforcement Authority to retain specific evidence for a longer period of time as part of an investigation:~~

~~For Requirements R1, R2, R3, R5, and R6, each responsible entity shall retain documentation as evidence for five years.~~

~~For Requirement R4, each responsible entity shall retain documentation of the current GMD Vulnerability Assessment and the preceding GMD Vulnerability Assessment.~~

~~For Requirement R7, each responsible entity shall retain documentation as evidence for five years or until all actions in the Corrective Action Plan are completed, whichever is later.~~

~~If a Planning Coordinator, Transmission Planner, Transmission Owner, or Generator Owner is found non-compliant it shall keep information related to the non-compliance until mitigation is complete and approved or for the time specified above, whichever is longer.~~

~~The Compliance Enforcement Authority shall keep the last audit records and all requested and submitted subsequent audit records.~~

#### ~~1.3.~~ **Compliance Monitoring and Assessment Processes:**

~~Compliance Audits~~

~~Self-Certifications~~

~~Spot Checking~~

~~Compliance Investigations~~

~~Self-Reporting~~

~~Complaints~~

~~1.4. Additional Compliance Information~~

~~None~~



**Table of Compliance Elements**

R-#	Time Horizon	VRF	Violation-Severity Levels			
			Lower-VSL	Moderate-VSL	High-VSL	Severe-VSL
<b>R1</b>	Long-term Planning	Lower	N/A	N/A	N/A	The Planning Coordinator, in conjunction with its Transmission Planner(s), failed to determine and identify individual or joint responsibilities of the Planning Coordinator and Transmission Planner(s) in the Planning Coordinator's planning area for maintaining models and performing the study or studies needed to complete GMD Vulnerability Assessment(s).
<b>R2</b>	Long-term Planning	High	N/A	N/A	The responsible entity did not maintain either System models or GIC System models of the responsible	The responsible entity did not maintain both System models and GIC System models of the responsible

**TPL-007-1—2— Transmission System Planned Performance for Geomagnetic Disturbance Events**

					entity's planning area for performing the study or studies needed to complete GMD Vulnerability Assessment(s).	entity's planning area for performing the study or studies needed to complete GMD Vulnerability Assessment(s).
<b>R3</b>	Long-term Planning	Medium	N/A	N/A	N/A	The responsible entity did not have criteria for acceptable System steady-state voltage performance for its System during the benchmark GMD event described in Attachment 1 as required.
<b>R4</b>	Long-term Planning	High	The responsible entity completed a GMD Vulnerability Assessment, but it was more than 60 calendar months and less than or equal to 64 calendar months since the last GMD Vulnerability Assessment.	The responsible entity's completed GMD Vulnerability Assessment failed to satisfy one of the elements listed in Requirement R4, Parts 4.1 through 4.3;  OR The responsible entity completed a GMD Vulnerability Assessment, but it	The responsible entity's completed GMD Vulnerability Assessment failed to satisfy two of the elements listed in Requirement R4, Parts 4.1 through 4.3;  OR The responsible entity completed a GMD Vulnerability Assessment, but it	The responsible entity's completed GMD Vulnerability Assessment failed to satisfy three of the elements listed in Requirement R4, Parts 4.1 through 4.3;  OR The responsible entity completed a GMD Vulnerability Assessment, but it

				was more than 64 calendar months and less than or equal to 68 calendar months since the last GMD Vulnerability Assessment.	was more than 68 calendar months and less than or equal to 72 calendar months since the last GMD Vulnerability Assessment.	was more than 72 calendar months since the last GMD Vulnerability Assessment;  OR The responsible entity does not have a completed GMD Vulnerability Assessment.
R5	Long-term Planning	Medium	The responsible entity provided the effective GIC time series, GIC(t), in response to written request, but did so more than 90 calendar days and less than or equal to 100 calendar days after receipt of a written request.	The responsible entity provided the effective GIC time series, GIC(t), in response to written request, but did so more than 100 calendar days and less than or equal to 110 calendar days after receipt of a written request.	The responsible entity provided the effective GIC time series, GIC(t), in response to written request, but did so more than 110 calendar days after receipt of a written request.	The responsible entity did not provide the maximum effective GIC value to the Transmission Owner and Generator Owner that owns each applicable BES power transformer in the planning area;  OR The responsible entity did not provide the effective GIC time series, GIC(t), upon written request.

<p><b>R6</b></p>	<p>Long-term Planning</p>	<p>Medium</p>	<p>The responsible entity failed to conduct a thermal impact assessment for 5% or less or one of its solely owned and jointly owned applicable BES power transformers (whichever is greater) where the maximum effective GIC value provided in Requirement R5, Part 5.1, is 75 A or greater per phase; OR The responsible entity conducted a thermal impact assessment for its solely owned and jointly owned applicable BES power transformers where the maximum effective GIC value provided in Requirement R5, Part 5.1, is 75 A or greater per phase but did so more than 24 calendar months and less than</p>	<p>The responsible entity failed to conduct a thermal impact assessment for more than 5% up to (and including) 10% or two of its solely owned and jointly owned applicable BES power transformers (whichever is greater) where the maximum effective GIC value provided in Requirement R5, Part 5.1, is 75 A or greater per phase; OR The responsible entity conducted a thermal impact assessment for its solely owned and jointly owned applicable BES power transformers where the maximum effective GIC value provided in Requirement R5, Part 5.1, is 75 A or greater per phase but did so</p>	<p>The responsible entity failed to conduct a thermal impact assessment for more than 10% up to (and including) 15% or three of its solely owned and jointly owned applicable BES power transformers (whichever is greater) where the maximum effective GIC value provided in Requirement R5, Part 5.1, is 75 A or greater per phase; OR The responsible entity conducted a thermal impact assessment for its solely owned and jointly owned applicable BES power transformers where the maximum effective GIC value provided in Requirement R5, Part 5.1, is 75 A or greater per phase but did so</p>	<p>The responsible entity failed to conduct a thermal impact assessment for more than 15% or more than three of its solely owned and jointly owned applicable BES power transformers (whichever is greater) where the maximum effective GIC value provided in Requirement R5, Part 5.1, is 75 A or greater per phase; OR The responsible entity conducted a thermal impact assessment for its solely owned and jointly owned applicable BES power transformers where the maximum effective GIC value provided in Requirement R5, Part 5.1, is 75 A or greater per phase but did so more than 30 calendar</p>
------------------	---------------------------	---------------	--	---	--	--

TPL-007-1—2— Transmission System Planned Performance for Geomagnetic Disturbance Events

			<p><del>or equal to 26 calendar months of receiving GIC flow information specified in Requirement R5, Part 5.1.</del></p>	<p><del>more than 26 calendar months and less than or equal to 28 calendar months of receiving GIC flow information specified in Requirement R5, Part 5.1;</del>  OR  The responsible entity failed to include one of the required elements as listed in Requirement R6, Parts 6.1 through 6.3.</p>	<p><del>more than 28 calendar months and less than or equal to 30 calendar months of receiving GIC flow information specified in Requirement R5, Part 5.1;</del>  OR  The responsible entity failed to include two of the required elements as listed in Requirement R6, Parts 6.1 through 6.3.</p>	<p><del>months of receiving GIC flow information specified in Requirement R5, Part 5.1;</del>  OR  The responsible entity failed to include three of the required elements as listed in Requirement R6, Parts 6.1 through 6.3.</p>
<b>R7</b>	Long-term Planning	High	N/A	<p>The responsible entity's Corrective Action Plan failed to comply with one of the elements in Requirement R7, Parts 7.1 through 7.3.</p>	<p>The responsible entity's Corrective Action Plan failed to comply with two of the elements in Requirement R7, Parts 7.1 through 7.3.</p>	<p>The responsible entity's Corrective Action Plan failed to comply with all three of the elements in Requirement R7, Parts 7.1 through 7.3;</p> OR <p>The responsible entity did not have a Corrective Action Plan as required by Requirement R7.</p>

~~D.A. Regional Variances~~

~~None.~~

~~E. Interpretations~~

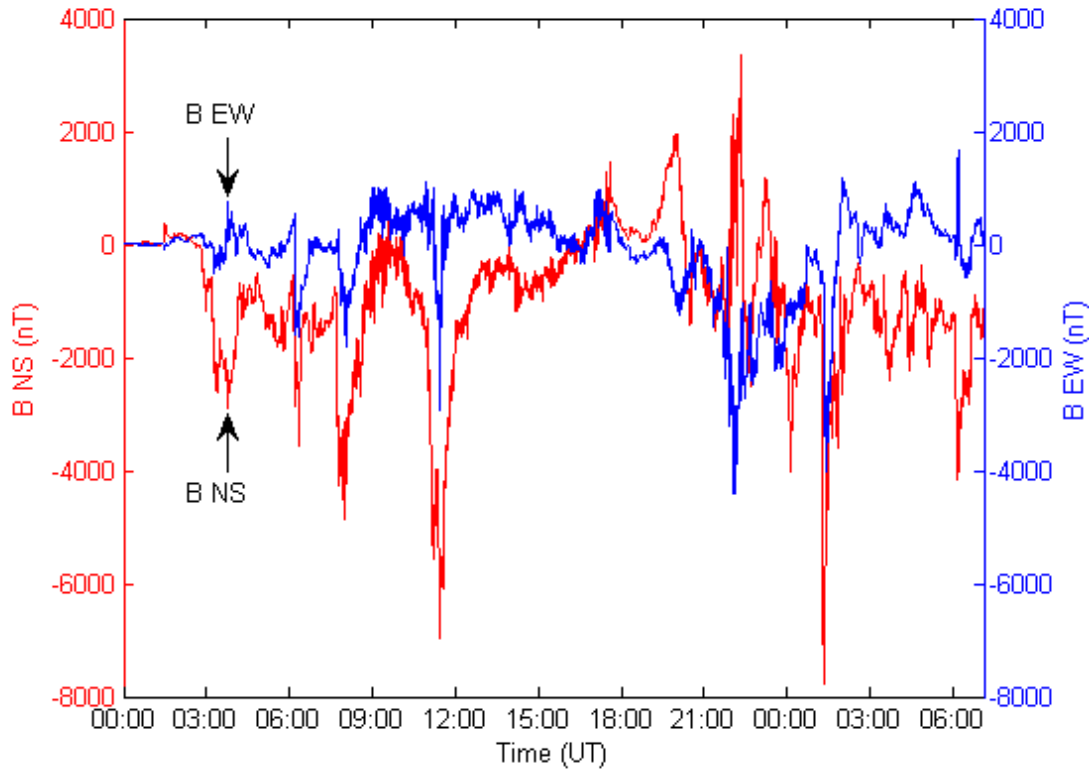
~~None.~~

~~F.A. Associated Documents~~

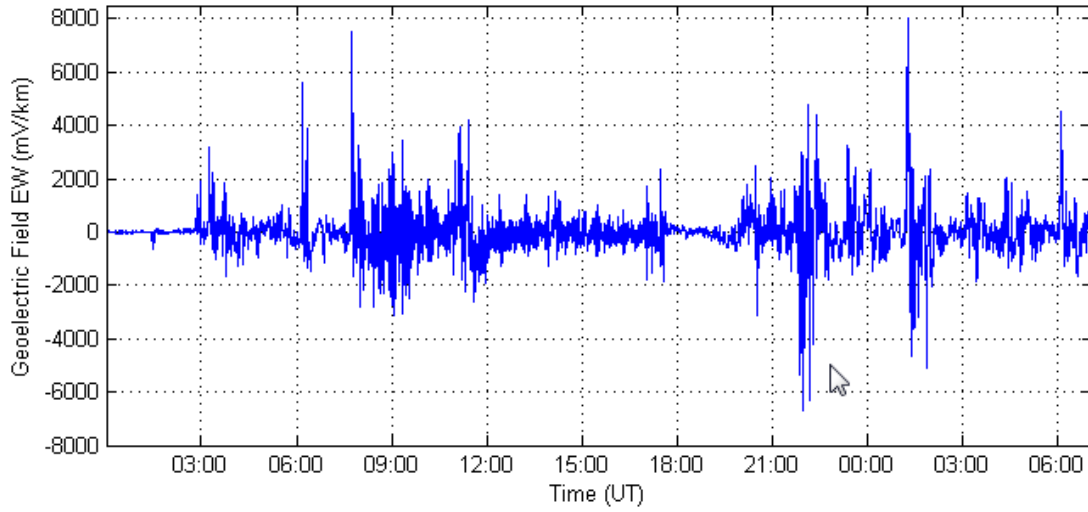
~~None.~~

~~Version History~~

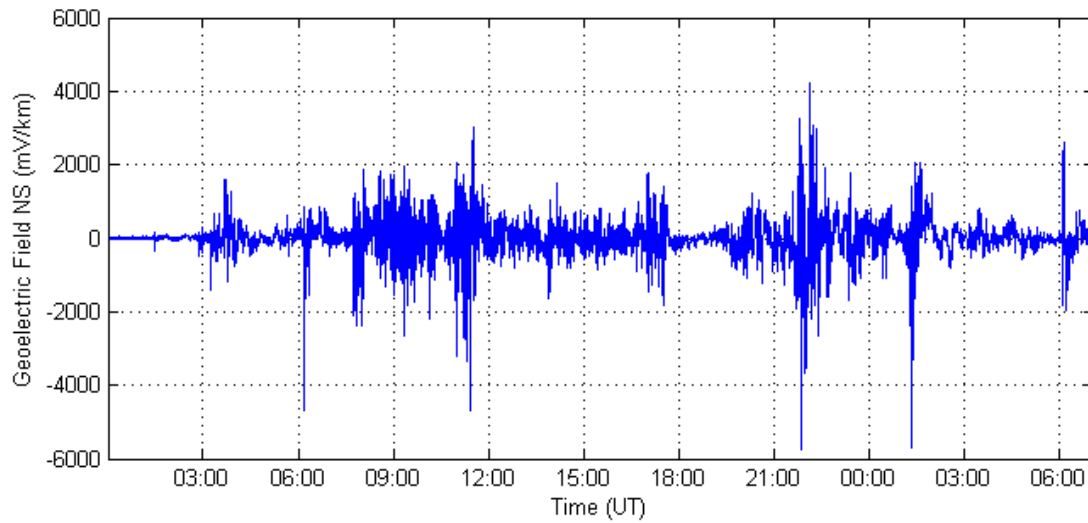
Version	Date	Action	Change Tracking
1	December 17, 2014	Adopted by the NERC Board of Trustees	



**Figure 3: Benchmark Geomagnetic Field Waveform**  
**Red  $B_n$  (Northward), Blue  $B_e$  (Eastward)**



**Figure 4: Benchmark Geoelectric Field Waveform  $E_E$  (Eastward)**

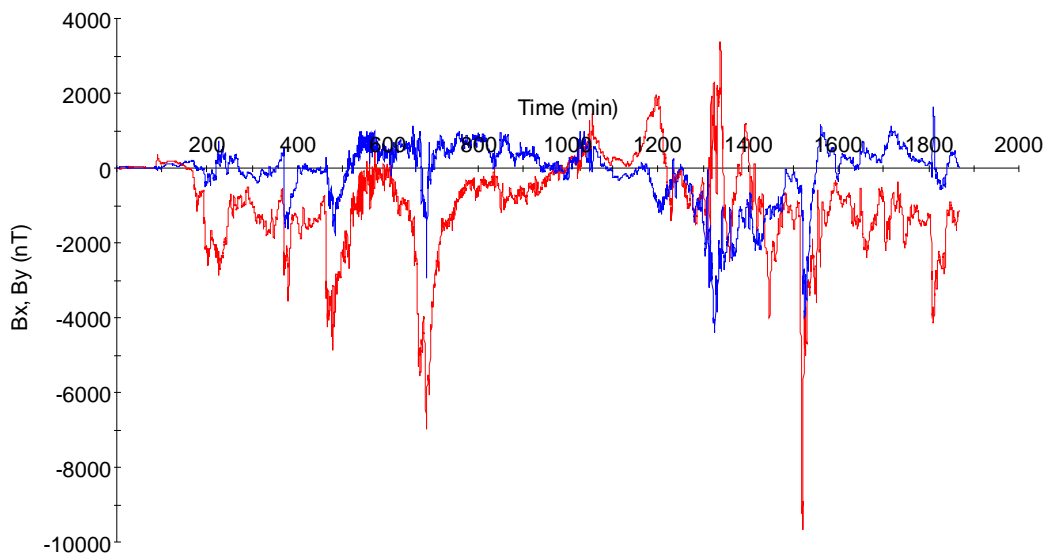


**Figure 5: Benchmark Geoelectric Field Waveform  $E_N$  (Northward)**

**Reference Geomagnetic Field Time Series or Waveform for the Supplemental GMD Event<sup>11</sup>**

The geomagnetic field measurement record of the March 13-14, 1989 GMD event, measured at the NRCan Ottawa geomagnetic observatory, is the basis for the reference geomagnetic field waveform to be used to calculate the GIC time series,  $GIC(t)$ , required for transformer thermal impact assessment for the supplemental GMD event. The supplemental GMD event waveform differs from the benchmark GMD event waveform in that the supplemental GMD event waveform has a local enhancement.

The geomagnetic latitude of the Ottawa geomagnetic observatory is  $55^\circ$ ; therefore, the amplitudes of the geomagnetic field measurement data were scaled up to the  $60^\circ$  reference geomagnetic latitude (see Figure 6) such that the resulting peak geoelectric field amplitude computed using the reference earth model was 12 V/km (see Figure 7). The sampling rate for the geomagnetic field waveform is 10 seconds.<sup>12</sup> To use this geoelectric field time series when a different earth model is applicable, it should be scaled with the appropriate supplemental conductivity scaling factor  $\beta_s$ .

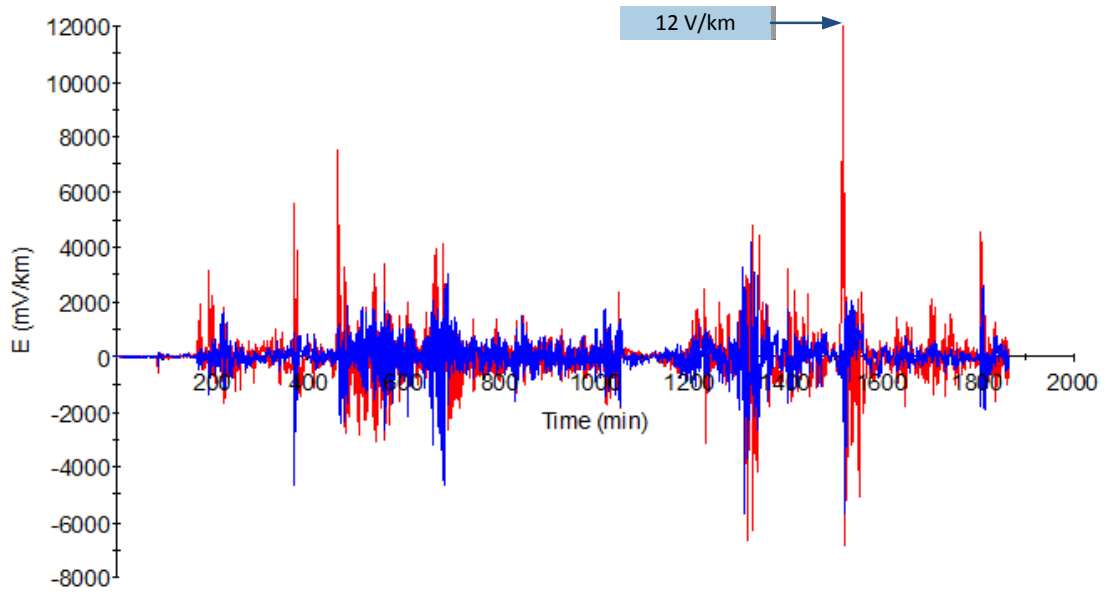


**Figure 6: Supplemental Geomagnetic Field Waveform  
Red  $B_N$  (Northward), Blue  $B_E$  (Eastward)**

<sup>11</sup> Refer to the Supplemental Geomagnetic Disturbance Event Description white paper for details on the determination of the reference geomagnetic field waveform: <http://www.nerc.com/pa/Stand/Pages/Project-2013-03-Geomagnetic-Disturbance-Mitigation.aspx>.

<sup>12</sup> The data file of the benchmark geomagnetic field waveform is available on the NERC GMD Task Force project webpage: [http://www.nerc.com/comm/PC/Pages/Geomagnetic-Disturbance-Task-Force-\(GMDTF\)-2013.aspx](http://www.nerc.com/comm/PC/Pages/Geomagnetic-Disturbance-Task-Force-(GMDTF)-2013.aspx).

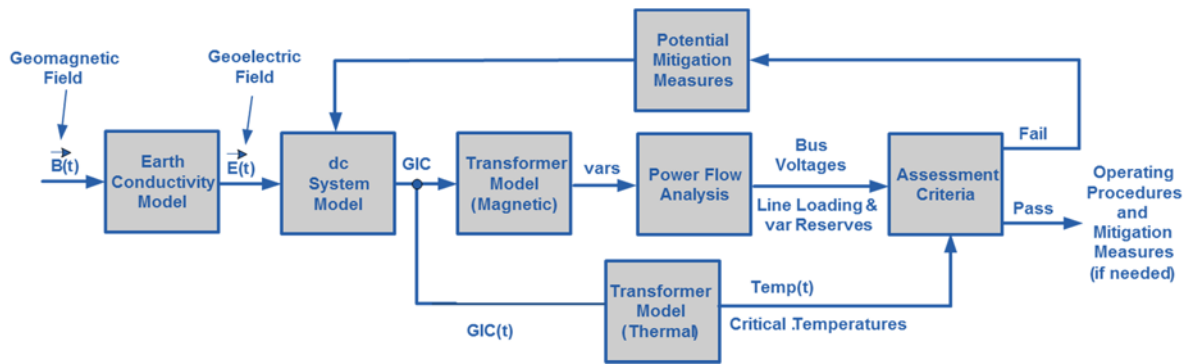




**Figure 7: Supplemental Geoelectric Field Waveform  
Blue E<sub>N</sub> (Northward), Red E<sub>E</sub> (Eastward)**

## Guidelines and Technical Basis

The diagram below provides an overall view of the GMD Vulnerability Assessment process:



The requirements in this standard cover various aspects of the GMD Vulnerability Assessment process.

### Benchmark GMD Event (Attachment 1)

The benchmark GMD event defines the geoelectric field values used to compute GIC flows that are needed to conduct a benchmark GMD Vulnerability Assessment. ~~A~~ The Benchmark Geomagnetic Disturbance Event Description, May 2016<sup>13</sup> white paper ~~that~~ includes the event description, analysis, and example calculations ~~is available on the Project 2013-03-Geomagnetic Disturbance Mitigation project page.~~

### Supplemental GMD Event (Attachment 1)

The supplemental GMD event defines the geoelectric field values used to compute GIC flows that are needed to conduct a supplemental GMD Vulnerability Assessment. The Supplemental Geomagnetic Disturbance Event Description, October 2017<sup>14</sup> white paper includes the event description and analysis.

### Requirement R2

A GMD Vulnerability Assessment requires a GIC System model, which is a dc representation of the System, to calculate GIC flow. In a GMD Vulnerability Assessment, GIC simulations are used to determine transformer Reactive Power absorption and transformer thermal response. Details for developing the GIC System model are provided in the NERC GMD Task Force guide: Application Guide for Computing Geomagnetically-Induced Current in the Bulk Power System. ~~The guide is available at: —, December 2013.~~<sup>15</sup>

Underground pipe-type cables present a special modeling situation in that the steel pipe that encloses the power conductors significantly reduces the geoelectric field induced into the conductors themselves, while they remain a path for GIC. Solid dielectric cables that are not

<sup>13</sup> <http://www.nerc.com/pa/stand/Pages/TPL0071RI.aspx>.

<sup>14</sup> <http://www.nerc.com/pa/Stand/Pages/Project-2013-03-Geomagnetic-Disturbance-Mitigation.aspx>.

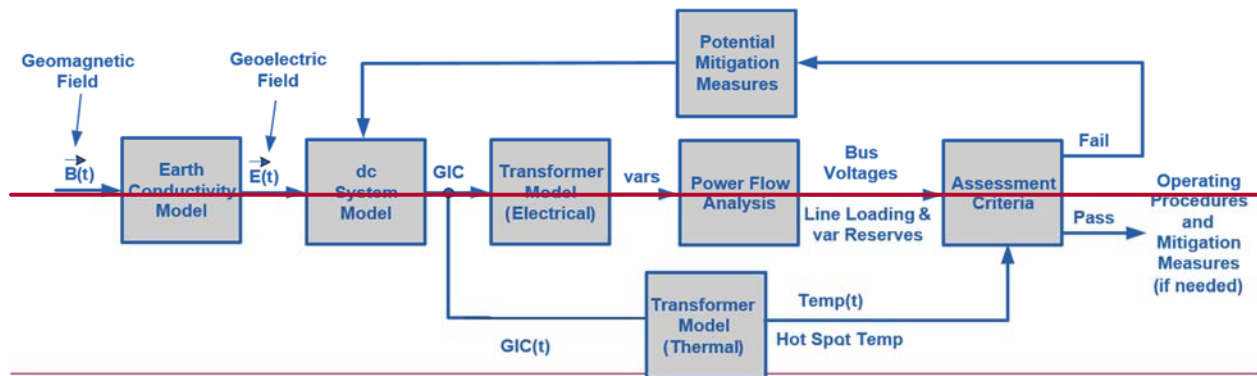
<sup>15</sup> [http://www.nerc.com/comm/PC/Geomagnetic%20Disturbance%20Task%20Force%20GMDTF%202013/GIC%20Application%20Guide%202013\\_approved.pdf](http://www.nerc.com/comm/PC/Geomagnetic%20Disturbance%20Task%20Force%20GMDTF%202013/GIC%20Application%20Guide%202013_approved.pdf).

enclosed by a steel pipe will not experience a reduction in the induced geoelectric field. A planning entity should account for special modeling situations in the GIC system model, if applicable.

### Requirement R4

The GMD Geomagnetic Disturbance Planning Guide,<sup>16</sup> December 2013 developed by the NERC GMD Task Force provides technical information on GMD-specific considerations for planning studies. ~~It is available at:~~

~~The diagram below provides an overall view of the GMD Vulnerability Assessment process:~~



### Requirement R5

The transformer benchmark thermal impact assessment of transformers specified in Requirement R6 is based on GIC information for the benchmark benchmark GMD Event. This GIC information is determined by the planning entity through simulation of the GIC System model and must be provided to the entity responsible for conducting the thermal impact assessment. GIC information should be provided in accordance with Requirement R5 each time the GMD Vulnerability Assessment is performed since, by definition, the GMD Vulnerability Assessment includes a documented evaluation of susceptibility to localized equipment damage due to GMD.

The maximum effective GIC value provided in Part 5.1 is used for transformer the benchmark thermal impact assessment. Only those transformers that experience an effective GIC value of 75 A or greater per phase require evaluation in Requirement R6.

GIC(t) provided in Part 5.2 is used to convert the steady -state GIC flows to time-series GIC data for transformer the benchmark thermal impact assessment. of transformers. This information may be needed by one or more of the methods for performing a benchmark thermal impact assessment. Additional information is in the following section and the thermal impact assessment white paper Transformer Thermal Impact Assessment White Paper,<sup>17</sup> October 2017.

<sup>16</sup> [http://www.nerc.com/comm/PC/Geomagnetic%20Disturbance%20Task%20Force%20GMDTF%202013/GMD%20Planning%20Guide\\_approved.pdf](http://www.nerc.com/comm/PC/Geomagnetic%20Disturbance%20Task%20Force%20GMDTF%202013/GMD%20Planning%20Guide_approved.pdf).

<sup>17</sup> <http://www.nerc.com/pa/Stand/Pages/Project-2013-03-Geomagnetic-Disturbance-Mitigation.aspx>.

The peak GIC value of 75 Amps per phase has been shown through thermal modeling to be a conservative threshold below which the risk of exceeding known temperature limits established by technical organizations is low.

### **Requirement R6**

The benchmark thermal impact assessment of a power transformer may be based on manufacturer-provided GIC capability curves, thermal response simulation, thermal impact screening, or other technically justified means. Approaches for conducting the assessment are presented in the *Transformer Thermal Impact Assessment* ~~white paper posted on the project page~~ White Paper ERO Enterprise-Endorsed Implementation Guidance<sup>18</sup> for this requirement. This ERO-Endorsed document is posted on the NERC Compliance Guidance<sup>19</sup> webpage.

Transformers are exempt from the benchmark thermal impact assessment requirement if the effective GIC value for the transformer is less than 75 A per phase, as determined by a GIC analysis of the System. Justification for this criterion is provided in the *Screening Criterion for Transformer Thermal Impact Assessment* ~~white paper posted on the project page~~ White Paper,<sup>20</sup> **October 2017**. A documented design specification exceeding this value is also a justifiable threshold criterion that exempts a transformer from Requirement R6.

The benchmark threshold criteria and its associated transformer thermal impact must be evaluated on the basis of effective GIC. Refer to the white papers for additional information.

### **Requirement R7**

Technical considerations for GMD mitigation planning, including operating and equipment strategies, are available in Chapter 5 of the GMD Geomagnetic Disturbance Planning Guide,<sup>21</sup> **December 2013**. Additional information is available in the *2012 Special Reliability Assessment Interim Report: Effects of Geomagnetic Disturbances on the Bulk-Power System*,<sup>22</sup> **February 2012**.

### **Requirement R8**

The Geomagnetic Disturbance Planning Guide,<sup>23</sup> **December 2013** developed by the NERC GMD Task Force provides technical information on GMD-specific considerations for planning studies.

The supplemental GMD Vulnerability Assessment process is similar to the benchmark GMD Vulnerability Assessment process described under Requirement R4.

---

<sup>18</sup> [http://www.nerc.com/pa/comp/guidance/EROEndorsedImplementationGuidance/TPL-007-1 Transformer Thermal Impact Assessment White Paper.pdf](http://www.nerc.com/pa/comp/guidance/EROEndorsedImplementationGuidance/TPL-007-1_Transformer_Thermal_Impact_Assessment_White_Paper.pdf).

<sup>19</sup> <http://www.nerc.com/pa/comp/guidance/Pages/default.aspx>.

<sup>20</sup> <http://www.nerc.com/pa/Stand/Pages/Project-2013-03-Geomagnetic-Disturbance-Mitigation.aspx>.

<sup>21</sup> [http://www.nerc.com/comm/PC/Geomagnetic%20Disturbance%20Task%20Force%20GMDTF%202013/GMD%20Planning%20Guide\\_approved.pdf](http://www.nerc.com/comm/PC/Geomagnetic%20Disturbance%20Task%20Force%20GMDTF%202013/GMD%20Planning%20Guide_approved.pdf).

<sup>22</sup> <http://www.nerc.com/pa/RAPA/ra/Reliability%20Assessments%20DL/2012GMD.pdf>.

<sup>23</sup> [http://www.nerc.com/comm/PC/Geomagnetic%20Disturbance%20Task%20Force%20GMDTF%202013/GMD%20Planning%20Guide\\_approved.pdf](http://www.nerc.com/comm/PC/Geomagnetic%20Disturbance%20Task%20Force%20GMDTF%202013/GMD%20Planning%20Guide_approved.pdf).

**Requirement R9**

The supplemental thermal impact assessment specified of transformers in Requirement R10 is based on GIC information for the supplemental GMD Event. This GIC information is determined by the planning entity through simulation of the GIC System model and must be provided to the entity responsible for conducting the thermal impact assessment. GIC information should be provided in accordance with Requirement R9 each time the GMD Vulnerability Assessment is performed since, by definition, the GMD Vulnerability Assessment includes a documented evaluation of susceptibility to localized equipment damage due to GMD.

The maximum effective GIC value provided in Part 9.1 is used for the supplemental thermal impact assessment. Only those transformers that experience an effective GIC value of 85 A or greater per phase require evaluation in Requirement R10.

GIC(t) provided in Part 9.2 is used to convert the steady state GIC flows to time-series GIC data for the supplemental thermal impact assessment of transformers. This information may be needed by one or more of the methods for performing a supplemental thermal impact assessment. Additional information is in the following section.

The peak GIC value of 85 Amps per phase has been shown through thermal modeling to be a conservative threshold below which the risk of exceeding known temperature limits established by technical organizations is low.

**Requirement R10**

The supplemental thermal impact assessment of a power transformer may be based on manufacturer-provided GIC capability curves, thermal response simulation, thermal impact screening, or other technically justified means. Approaches for conducting the assessment are presented in the *Transformer Thermal Impact Assessment White Paper ERO Enterprise-Endorsed Implementation Guidance*<sup>24</sup> discussed in the Requirement R6 section above. A later version of the *Transformer Thermal Impact Assessment White Paper*,<sup>25</sup> October 2017, has been developed to include updated information pertinent to the supplemental GMD event and supplemental thermal impact assessment.

Transformers are exempt from the supplemental thermal impact assessment requirement if the effective GIC value for the transformer is less than 85 A per phase, as determined by a GIC analysis of the System. Justification for this criterion is provided in the revised *Screening Criterion for Transformer Thermal Impact Assessment White Paper*,<sup>26</sup> October 2017. A documented design specification exceeding this value is also a justifiable threshold criterion that exempts a transformer from Requirement R10.

The supplemental threshold criteria and its associated transformer thermal impact must be evaluated on the basis of effective GIC. Refer to the white papers for additional information.

---

<sup>24</sup> [http://www.nerc.com/pa/comp/guidance/EROEndorsedImplementationGuidance/TPL-007-1\\_Transformer\\_Thermal\\_Impact\\_Assessment\\_White\\_Paper.pdf](http://www.nerc.com/pa/comp/guidance/EROEndorsedImplementationGuidance/TPL-007-1_Transformer_Thermal_Impact_Assessment_White_Paper.pdf).

<sup>25</sup> <http://www.nerc.com/pa/Stand/Pages/Project-2013-03-Geomagnetic-Disturbance-Mitigation.aspx>.

<sup>26</sup> <http://www.nerc.com/pa/Stand/Pages/Project-2013-03-Geomagnetic-Disturbance-Mitigation.aspx>.

### **Requirement R11**

Technical considerations for GIC monitoring are contained in Chapter 6 of the 2012 *Special Reliability Assessment Interim Report: Effects of Geomagnetic Disturbances on the Bulk-Power System*,<sup>27</sup> February 2012. GIC monitoring is generally performed by Hall effect transducers that are attached to the neutral of the wye-grounded transformer. Data from GIC monitors is useful for model validation and situational awareness.

Responsible entities consider the following in developing a process for obtaining GIC monitor data:

- **Monitor locations.** An entity's operating process may be constrained by location of existing GIC monitors. However, when planning for additional GIC monitoring installations consider that data from monitors located in areas found to have high GIC based on system studies may provide more useful information for validation and situational awareness purposes. Conversely, data from GIC monitors that are located in the vicinity of transportation systems using direct current (e.g., subways or light rail) may be unreliable.
- **Monitor specifications.** Capabilities of Hall effect transducers, existing and planned, should be considered in the operating process. When planning new GIC monitor installations, consider monitor data range (e.g., -500 A through + 500 A) and ambient temperature ratings consistent with temperatures in the region in which the monitor will be installed.
- **Sampling Interval.** An entity's operating process may be constrained by capabilities of existing GIC monitors. However, when possible specify data sampling during periods of interest at a rate of 10 seconds or faster.
- **Collection Periods.** The process should specify when the entity expects GIC data to be collected. For example, collection could be required during periods where the Kp index is above a threshold, or when GIC values are above a threshold. Determining when to discontinue collecting GIC data should also be specified to maintain consistency in data collection.
- **Data format.** Specify time and value formats. For example, Greenwich Mean Time (GMT) (MM/DD/YYYY HH:MM:SS) and GIC Value (Ampere). Positive (+) and negative (-) signs indicate direction of GIC flow. Positive reference is flow from ground into transformer neutral. Time fields should indicate the sampled time rather than system or SCADA time if supported by the GIC monitor system.
- **Data retention.** The entity's process should specify data retention periods, for example 1 year. Data retention periods should be adequately long to support availability for the entity's model validation process and external reporting requirements, if any.

---

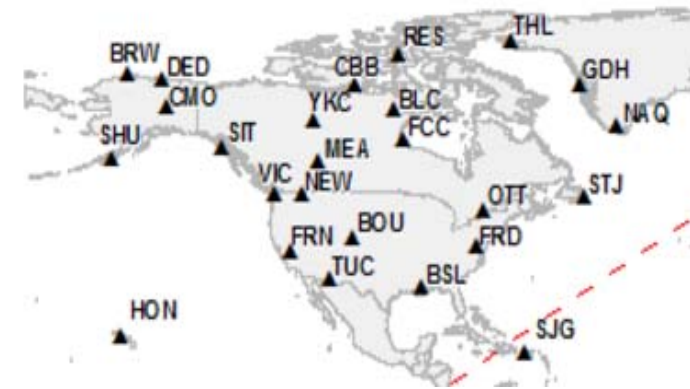
<sup>27</sup> <http://www.nerc.com/pa/RAPA/ra/Reliability%20Assessments%20DL/2012GMD.pdf>.

- Additional information. The entity's process should specify collection of other information necessary for making the data useful, for example monitor location and type of neutral connection (e.g., three-phase or single-phase).

### **Requirement R12**

Magnetometers measure changes in the earth's magnetic field. Entities should obtain data from the nearest accessible magnetometer. Sources of magnetometer data include:

- Observatories such as those operated by U.S. Geological Survey and Natural Resources Canada, see figure below for locations:<sup>28</sup>



- Research institutions and academic universities;
- Entities with installed magnetometers.

Entities that choose to install magnetometers should consider equipment specifications and data format protocols contained in the latest version of the *INTERMAGNET Technical Reference Manual, Version 4.6, 2012.*<sup>29</sup>

### **Rationale:**

During development of ~~this standard~~ TPL-007-1, text boxes were embedded within the standard to explain the rationale for various parts of the standard. ~~Upon BOT approval, the~~ The text from the rationale text boxes was moved to this section. upon approval of TPL-007-1 by the NERC Board of Trustees. In developing TPL-007-2, the SDT has made changes to the sections below only when necessary for clarity. Changes are marked with brackets [ ].

### **Rationale for Applicability:**

Instrumentation transformers and station service transformers do not have significant impact on geomagnetically-induced current (GIC) flows; therefore, these transformers are not included in the applicability for this standard.

---

<sup>28</sup> <http://www.intermagnet.org/index-eng.php>.

<sup>29</sup> [http://www.intermagnet.org/publications/intermag\\_4-6.pdf](http://www.intermagnet.org/publications/intermag_4-6.pdf).

Terminal voltage describes line-to-line voltage.

**Rationale for R1:**

In some areas, planning entities may determine that the most effective approach to conduct a GMD Vulnerability Assessment is through a regional planning organization. No requirement in the standard is intended to prohibit a collaborative approach where roles and responsibilities are determined by a planning organization made up of one or more Planning Coordinator(s).

**Rationale for R2:**

A GMD Vulnerability Assessment requires a GIC System model to calculate GIC flow which is used to determine transformer Reactive Power absorption and transformer thermal response. Guidance for developing the GIC System model is provided in the ~~GIC~~ *Application Guide Computing Geomagnetically-Induced Current in the Bulk-Power System*,<sup>30</sup> December 2013, developed by the NERC GMD Task Force ~~and available at: —~~.

The System model specified in Requirement R2 is used in conducting steady state power flow analysis that accounts for the Reactive Power absorption of power transformer(s) due to GIC in the System.

The GIC System model includes all power transformer(s) with a high side, wye-grounded winding with terminal voltage greater than 200 kV. The model is used to calculate GIC flow in the network.

The projected System condition for GMD planning may include adjustments to the System that are executable in response to space weather information. These adjustments could include, for example, recalling or postponing maintenance outages.

The Violation Risk Factor (VRF) for Requirement R2 is changed from Medium to High. This change is for consistency with the VRF for approved standard TPL-001-4 Requirement R1, which is proposed for revision in the NERC filing dated August 29, 2014 (Docket No. RM12-1-000). NERC guidelines require consistency among Reliability Standards.

**Rationale for R3:**

Requirement R3 allows a responsible entity the flexibility to determine the System steady state voltage criteria for System steady state performance in Table 1. Steady state voltage limits are an example of System steady state performance criteria.

**Rationale for R4:**

The GMD Vulnerability Assessment includes steady state power flow analysis and the supporting study or studies using the models specified in Requirement R2 that account for the effects of GIC. Performance criteria are specified in Table 1.

---

<sup>30</sup> [http://www.nerc.com/comm/PC/Geomagnetic%20Disturbance%20Task%20Force%20GMDTF%202013/GIC%20Application%20Guide%202013\\_approved.pdf](http://www.nerc.com/comm/PC/Geomagnetic%20Disturbance%20Task%20Force%20GMDTF%202013/GIC%20Application%20Guide%202013_approved.pdf).



At least one System On-Peak Load and at least one System Off-Peak Load must be examined in the analysis.

Distribution of GMD Vulnerability Assessment results provides a means for sharing relevant information with other entities responsible for planning reliability. Results of GIC studies may affect neighboring systems and should be taken into account by planners.

The GMD Geomagnetic Disturbance Planning Guide,<sup>31</sup> December 2013 developed by the NERC GMD Task Force provides technical information on GMD-specific considerations for planning studies. ~~It is available at:~~

The provision of information in Requirement R4, Part 4.3, shall be subject to the legal and regulatory obligations for the disclosure of confidential and/or sensitive information.

**Rationale for R5:**

This GIC information is necessary for determining the thermal impact of GIC on transformers in the planning area and must be provided to entities responsible for performing the thermal impact assessment so that they can accurately perform the assessment. GIC information should be provided in accordance with Requirement R5 as part of the GMD Vulnerability Assessment process since, by definition, the GMD Vulnerability Assessment includes documented evaluation of susceptibility to localized equipment damage due to GMD.

The maximum effective GIC value provided in Part 5.1 is used for transformer thermal impact assessment.

GIC(t) provided in Part 5.2 can alternatively be used to convert the steady -state GIC flows to time-series GIC data for transformer thermal impact assessment. This information may be needed by one or more of the methods for performing a thermal impact assessment. Additional guidance is available in the *Transformer Thermal Impact Assessment* ~~white paper:~~ White Paper,<sup>32</sup> October 2017.

A Transmission Owner or Generator Owner that desires GIC(t) may request it from the planning entity. The planning entity shall provide GIC(t) upon request once GIC has been calculated, but no later than 90 calendar days after receipt of a request from the owner and after completion of Requirement R5, Part 5.1.

The provision of information in Requirement R5 shall be subject to the legal and regulatory obligations for the disclosure of confidential and/or sensitive information.

---

<sup>31</sup> [http://www.nerc.com/comm/PC/Geomagnetic%20Disturbance%20Task%20Force%20GMDTF%202013/GMD%20Planning%20Guide\\_approved.pdf](http://www.nerc.com/comm/PC/Geomagnetic%20Disturbance%20Task%20Force%20GMDTF%202013/GMD%20Planning%20Guide_approved.pdf).

<sup>32</sup> <http://www.nerc.com/pa/Stand/Pages/Project-2013-03-Geomagnetic-Disturbance-Mitigation.aspx>.

**Rationale for R6:**

The transformer thermal impact screening criterion has been revised from 15 A per phase to 75 A per phase- [for the benchmark GMD event]. Only those transformers that experience an effective GIC value of 75 A per phase or greater require evaluation in Requirement R6. The justification is provided in the Thermal Screening Criterion ~~white paper~~for Transformer Thermal Impact Assessment White Paper,<sup>33</sup> October 2017.

The thermal impact assessment may be based on manufacturer-provided GIC capability curves, thermal response simulation, thermal impact screening, or other technically justified means. The transformer thermal assessment will be repeated or reviewed using previous assessment results each time the planning entity performs a GMD Vulnerability Assessment and provides GIC information as specified in Requirement R5. Approaches for conducting the assessment are presented in the Transformer Thermal Impact Assessment ~~white paper posted on the project page~~White Paper,<sup>34</sup> October 2017.

Thermal impact assessments are provided to the planning entity, as determined in Requirement R1, so that identified issues can be included in the GMD Vulnerability Assessment (R4), and the Corrective Action Plan (R7) as necessary.

Thermal impact assessments of non-BES transformers are not required because those transformers do not have a wide-area effect on the reliability of the interconnected Transmission system.

The provision of information in Requirement R6, Part 6.4, shall be subject to the legal and regulatory obligations for the disclosure of confidential and/or sensitive information.

**Rationale for R7:**

Corrective Action Plans are defined in the NERC Glossary of Terms:

*A list of actions and an associated timetable for implementation to remedy a specific problem.*

Corrective Action Plans must, subject to the vulnerabilities identified in the assessments, contain strategies for protecting against the potential impact of the Benchmarkbenchmark GMD event, based on factors such as the age, condition, technical specifications, system configuration, or location of specific equipment. Chapter 5 of the NERC GMD Task Force GMDGeomagnetic Disturbance Planning Guide,<sup>35</sup> December 2013 provides a list of mitigating measures that may be appropriate to address an identified performance issue.

---

<sup>33</sup> <http://www.nerc.com/pa/Stand/Pages/Project-2013-03-Geomagnetic-Disturbance-Mitigation.aspx>.

<sup>34</sup> <http://www.nerc.com/pa/Stand/Pages/Project-2013-03-Geomagnetic-Disturbance-Mitigation.aspx>.

<sup>35</sup> [http://www.nerc.com/comm/PC/Geomagnetic%20Disturbance%20Task%20Force%20GMDTF%202013/GMD%20Planning%20Guide\\_approved.pdf](http://www.nerc.com/comm/PC/Geomagnetic%20Disturbance%20Task%20Force%20GMDTF%202013/GMD%20Planning%20Guide_approved.pdf).

The provision of information in Requirement R7, Part 7.3, [\[Part 7.5 in TPL-007-2\]](#), shall be subject to the legal and regulatory obligations for the disclosure of confidential and/or sensitive information.

**Rationale for Table 3:**

Table 3 has been revised to use the same ground model designation, FL1, as is being used by USGS. The calculated scaling factor for FL1 is 0.74. [\[The scaling factor associated with the benchmark GMD event for the Florida earth model \(FL1\) has been updated to 0.76 in TPL-007-2 based on the earth model published on the USGS public website.\]](#)

# Implementation Plan

## Project 2013-03 Geomagnetic Disturbance Mitigation Reliability Standard TPL-007-2

### Applicable Standard

- TPL-007-2 - Transmission System Planned Performance for Geomagnetic Disturbance Events

### Requested Retirement

- TPL-007-1 - Transmission System Planned Performance for Geomagnetic Disturbance Events

### Prerequisite Standard

None

### Applicable Entities

- *Planning Coordinator with a planning area that includes a Facility or Facilities specified in Section 4.2 of the standard;*
- *Transmission Planner with a planning area that includes a Facility or Facilities specified in Section 4.2 of the standard;*
- *Transmission Owner who owns a Facility or Facilities specified in Section 4.2 of the standard; and*
- *Generator Owner who owns a Facility or Facilities specified in Section 4.2 of the standard.*

Section 4.2 states that the standard applies to facilities that include power transformer(s) with a high-side, wye-grounded winding with terminal voltage greater than 200 kV.

### Terms in the NERC Glossary of Terms

There are no new, modified, or retired terms.

### Background

On September 22, 2016, the Federal Energy Regulatory Commission (FERC) issued Order No. 830 approving Reliability Standard TPL-007-1 and its associated five-year Implementation Plan. In the Order, FERC also directed NERC to develop certain modifications to the standard. FERC established a deadline of 18 months from the effective date of Order No. 830 for completing the revisions, which is May 2018.

### General Considerations

This Implementation Plan is intended to integrate the new requirements in TPL-007-2 with the GMD Vulnerability Assessment process that is being implemented through approved TPL-007-1. At the time of the May 2018 filing deadline, many requirements in approved standard TPL-007-1 that lead to completion of the geomagnetic disturbance (GMD) Vulnerability Assessment will be in effect. Furthermore, many entities may be taking steps to complete studies or assessments that are

required by future enforceable requirements in TPL-007-1. The Implementation Plan phases in the requirements in TPL-007-2 based on the effective date of TPL-007-2, as follows:

- **Effective Date before January 1, 2021.** Implementation timeline supports applicable entities completing new requirements for supplemental GMD Vulnerability Assessments concurrently with requirements for the benchmark GMD Vulnerability Assessment (concurrent effective dates).
- **Effective Date on or after January 1, 2021.** Implementation timeline supports applicable entities completing the benchmark GMD Vulnerability Assessments before new requirements for supplemental GMD Vulnerability Assessments become effective.

### **Effective Date**

The effective date for the proposed Reliability Standard is provided below. Where the standard drafting team identified the need for a longer implementation period for compliance with a particular section of the proposed Reliability Standard (e.g., an entire Requirement or a portion thereof), the additional time for compliance with that section is specified below. These phased-in compliance dates represent the dates that entities must begin to comply with that particular section of the Reliability Standard, even where the Reliability Standard goes into effect at an earlier date.

### **Standard TPL-007-2**

Where approval by an applicable governmental authority is required, the standard shall become effective on the first day of the first calendar quarter that is three (3) months after the effective date of the applicable governmental authority's order approving the standard, or as otherwise provided for by the applicable governmental authority.

Where approval by an applicable governmental authority is not required, the standard shall become effective on the first day of the first calendar quarter that is three (3) months after the date the standard is adopted by the NERC Board of Trustees, or as otherwise provided for in that jurisdiction.

### **Phased-In Compliance Dates**

#### ***If TPL-007-2 becomes effective before January 1, 2021***

Implementation timeline supports applicable entities completing new requirements for supplemental GMD Vulnerability Assessments concurrently with requirements for the benchmark GMD Vulnerability Assessment (concurrent effective dates).

### **Compliance Date for TPL-007-2 Requirements R1 and R2**

Entities shall be required to comply with Requirements R1 and R2 upon the effective date of Reliability Standard TPL-007-2.

### **Compliance Date for TPL-007-2 Requirement R5**

Entities shall not be required to comply with Requirements R5 until six (6) months after the effective date of Reliability Standard TPL-007-2.

**Compliance Date for TPL-007-2 Requirement R9**

Entities shall not be required to comply with Requirement R9 until six (6) months after the effective date of Reliability Standard TPL-007-2.

**Compliance Date for TPL-007-2 Requirements R11 and R12**

Entities shall not be required to comply with Requirements R11 and R12 until 24 months after the effective date of Reliability Standard TPL-007-2.

**Compliance Date for TPL-007-2 Requirements R6 and R10**

Entities shall not be required to comply with Requirements R6 and R10 until 30 months after the effective date of Reliability Standard TPL-007-2.

**Compliance Date for TPL-007-2 Requirements R3, R4, and R8**

Entities shall not be required to comply with Requirements R3, R4, and R8 until 42 months after the effective date of Reliability Standard TPL-007-2.

**Compliance Date for TPL-007-2 Requirement R7**

Entities shall not be required to comply with Requirement R7 until 54 months after the effective date of Reliability Standard TPL-007-2.

***If TPL-007-2 becomes effective on or after January 1, 2021***

Implementation timeline supports applicable entities completing the benchmark GMD Vulnerability Assessments before new requirements for supplemental GMD Vulnerability Assessments become effective.

**Compliance Date for TPL-007-2 Requirements R1, R2, R5, and R6**

Entities shall be required to comply with Requirements R1, R2, R5, and R6 upon the effective date of Reliability Standard TPL-007-2.

**Compliance Date for TPL-007-2 Requirements R3 and R4**

Entities shall not be required to comply with Requirements R3 and R4 until 12 months after the effective date of Reliability Standard TPL-007-2.

**Compliance Date for TPL-007-2 Requirements R7, R11, and R12**

Entities shall not be required to comply with Requirements R7, R11, and R12 until 24 months after the effective date of Reliability Standard TPL-007-2.

**Compliance Date for TPL-007-2 Requirement R9**

Entities shall not be required to comply with Requirement R9 until 36 months after the effective date of Reliability Standard TPL-007-2.

### **Compliance Date for TPL-007-2 Requirement R10**

Entities shall not be required to comply with Requirement R10 until 60 months after the effective date of Reliability Standard TPL-007-2.

### **Compliance Date for TPL-007-2 Requirement R8**

Entities shall not be required to comply with Requirement R8 until 72 months after the effective date of Reliability Standard TPL-007-2.

### **Retirement Date**

#### **Standard TPL-007-1**

Reliability Standard TPL-007-1 shall be retired immediately prior to the effective date of TPL-007-2 in the particular jurisdiction in which the revised standard is becoming effective, provided that the TPL-007-1 Implementation Plan shall remain in effect to the extent necessary until the phased-in compliance dates above are implemented for TPL-007-2.

### **Initial Performance of Periodic Requirements**

Transmission Owners and Generator Owners are not required to comply with Requirement R6 prior to the compliance date for Requirement R6, regardless of when geomagnetically-induced current (GIC) flow information specified in Requirement R5, Part 5.1 is received.

Transmission Owners and Generator Owners are not required to comply with Requirement R10 prior to the compliance date for Requirement R10, regardless of when GIC flow information specified in Requirement R9, Part 9.1 is received.

# Implementation Plan

## Project 2013-03 Geomagnetic Disturbance Mitigation Reliability Standard TPL-007-2

### Applicable Standard(s)

- TPL-007-2 - Transmission System Planned Performance for Geomagnetic Disturbance Events

### Requested Retirement(s)

- TPL-007-1 - Transmission System Planned Performance for Geomagnetic Disturbance Events

### Prerequisite Standard(s)

None

### Applicable Entities

- *Planning Coordinator with a planning area that includes a Facility or Facilities specified in Section 4.2 of the standard;*
- *Transmission Planner with a planning area that includes a Facility or Facilities specified in Section 4.2 of the standard;*
- *Transmission Owner who owns a Facility or Facilities specified in Section 4.2 of the standard; and*
- *Generator Owner who owns a Facility or Facilities specified in Section 4.2 of the standard.*

Section 4.2 states that the standard applies to facilities that include power transformer(s) with a high-side, wye-grounded winding with terminal voltage greater than 200 kV.

### Terms in the NERC Glossary of Terms

There are no new, modified, or retired terms.

### Background

On September 22, 2016, the Federal Energy Regulatory Commission (FERC) issued Order No. 830 approving Reliability Standard TPL-007-1 and its associated five-year Implementation Plan. In the Order, FERC also directed NERC to develop certain modifications to the standard. FERC established a deadline of 18 months from the effective date of Order No. 830 for completing the revisions, which is May 2018.

### General Considerations

This Implementation Plan is intended to integrate the new requirements in TPL-007-2 with the GMD Vulnerability Assessment process that is being implemented through approved TPL-007-1. At the time of the May 2018 filing deadline, many requirements in approved standard TPL-007-1 that lead to completion of the GMDgeomagnetic disturbance (GMD) Vulnerability Assessment will be in effect. Furthermore, many entities may be taking steps to complete studies or assessments that are



required by future enforceable requirements in TPL-007-1. The Implementation Plan phases in the requirements in TPL-007-2 based on the effective date of TPL-007-2, as follows:

- **Effective Date before January 1, 2021.** Implementation timeline supports applicable entities completing new requirements for supplemental GMD Vulnerability Assessments concurrently with requirements for the benchmark GMD Vulnerability Assessment (concurrent effective dates).
- **Effective Date on or after January 1, 2021.** Implementation timeline supports applicable entities completing the benchmark GMD Vulnerability Assessments before new requirements for supplemental GMD Vulnerability Assessments become effective.

### **Effective Date ~~and Phased-In Compliance Dates~~**

The effective date for the proposed Reliability Standard is provided below. Where the standard drafting team identified the need for a longer implementation period for compliance with a particular section of ~~the~~ proposed Reliability Standard (e.g., an entire Requirement or a portion thereof), the additional time for compliance with that section is specified below. ~~The~~These phased-in compliance ~~date for those particular sections represents~~dates represent the ~~date~~dates that entities must begin to comply with that particular section of the Reliability Standard, even where the Reliability Standard goes into effect at an earlier date.

### **Standard TPL-007-2**

Where approval by an applicable governmental authority is required, the standard shall become effective on the first day of the first calendar quarter that is three (3) months after the effective date of the applicable governmental authority's order approving the standard, or as otherwise provided for by the applicable governmental authority.

Where approval by an applicable governmental authority is not required, the standard shall become effective on the first day of the first calendar quarter that is three (3) months after the date the standard is adopted by the NERC Board of Trustees, or as otherwise provided for in that jurisdiction.

### **Phased-In Compliance Dates**

#### ***If TPL-007-2 becomes effective before January 1, 2021***

Implementation timeline supports applicable entities completing new requirements for supplemental GMD Vulnerability Assessments concurrently with requirements for the benchmark GMD Vulnerability Assessment (concurrent effective dates).

#### **Compliance Date for TPL-007-2 Requirements R1 and R2**

Entities shall be required to comply with Requirements R1 and R2 upon the effective date of Reliability Standard TPL-007-2.

**Compliance Date for TPL-007-2 Requirement R5**

Entities shall not be required to comply with Requirements R5 until six (6) months after the effective date of Reliability Standard TPL-007-2.

**Compliance Date for TPL-007-2 Requirement R9**

Entities shall not be required to comply with Requirement R9 until six (6) months after the effective date of Reliability Standard TPL-007-2.

**Compliance Date for TPL-007-2 Requirements R11 and R12**

Entities shall not be required to comply with Requirements R11 and R12 until 24 months after the effective date of Reliability Standard TPL-007-2.

**Compliance Date for TPL-007-2 Requirements R6 and R10**

Entities shall not be required to comply with Requirements R6 and R10 until 30 months after the effective date of Reliability Standard TPL-007-2.

**Compliance Date for TPL-007-2 Requirements R3, R4, and R8**

Entities shall not be required to comply with Requirements R3, R4, and R8 until 42 months after the effective date of Reliability Standard TPL-007-2.

**Compliance Date for TPL-007-2 Requirement R7**

Entities shall not be required to comply with Requirement R7 until 54 months after the effective date of Reliability Standard TPL-007-2.

***If TPL-007-2 becomes effective on or after January 1, 2021***

Implementation timeline supports applicable entities completing the benchmark GMD Vulnerability Assessments before new requirements for supplemental GMD Vulnerability Assessments become effective.

**Compliance Date for TPL-007-2 Requirements R1, R2, R5, and R6**

Entities shall be required to comply with Requirements R1, R2, R5, and R6 upon the effective date of Reliability Standard TPL-007-2.

**Compliance Date for TPL-007-2 Requirements R3 and R4**

Entities shall not be required to comply with Requirements R3 and R4 until 12 months after the effective date of Reliability Standard TPL-007-2.

**Compliance Date for TPL-007-2 Requirements R7, R11, and R12**

Entities shall not be required to comply with Requirements R7, R11, and R12 until 24 months after the effective date of Reliability Standard TPL-007-2.

### **Compliance Date for TPL-007-2 Requirement R9**

Entities shall not be required to comply with Requirement R9 until 36 months after the effective date of Reliability Standard TPL-007-2.

### **Compliance Date for TPL-007-2 Requirement R10**

Entities shall not be required to comply with Requirement R10 until 60 months after the effective date of Reliability Standard TPL-007-2.

### **Compliance Date for TPL-007-2 Requirement R8**

Entities shall not be required to comply with Requirement R8 until 72 months after the effective date of Reliability Standard TPL-007-2.

### **Retirement Date**

#### **Standard TPL-007-1**

Reliability Standard TPL-007-1 shall be retired immediately prior to the effective date of TPL-007-2 in the particular jurisdiction in which the revised standard is becoming effective, provided that the TPL-007-1 Implementation Plan shall remain in effect to the extent necessary until the phased-in compliance dates above are implemented for TPL-007-2.

### **Initial Performance of Periodic Requirements**

Transmission Owners and Generator Owners are not required to comply with Requirement R6 prior to the compliance date for Requirement R6, regardless of when geomagnetically-induced current (GIC) flow information specified in Requirement R5, Part 5.1 is received.

Transmission Owners and Generator Owners are not required to comply with Requirement R10 prior to the compliance date for Requirement R10, regardless of when GIC flow information specified in Requirement R9, Part 9.1 is received.

**NERC**

NORTH AMERICAN ELECTRIC  
RELIABILITY CORPORATION

# Supplemental Geomagnetic Disturbance Event Description

Project 2013-03 GMD Mitigation

October 2017

**RELIABILITY | ACCOUNTABILITY**



3353 Peachtree Road NE  
Suite 600, North Tower  
Atlanta, GA 30326  
404-446-2560 | [www.nerc.com](http://www.nerc.com)

# Table of Contents

---

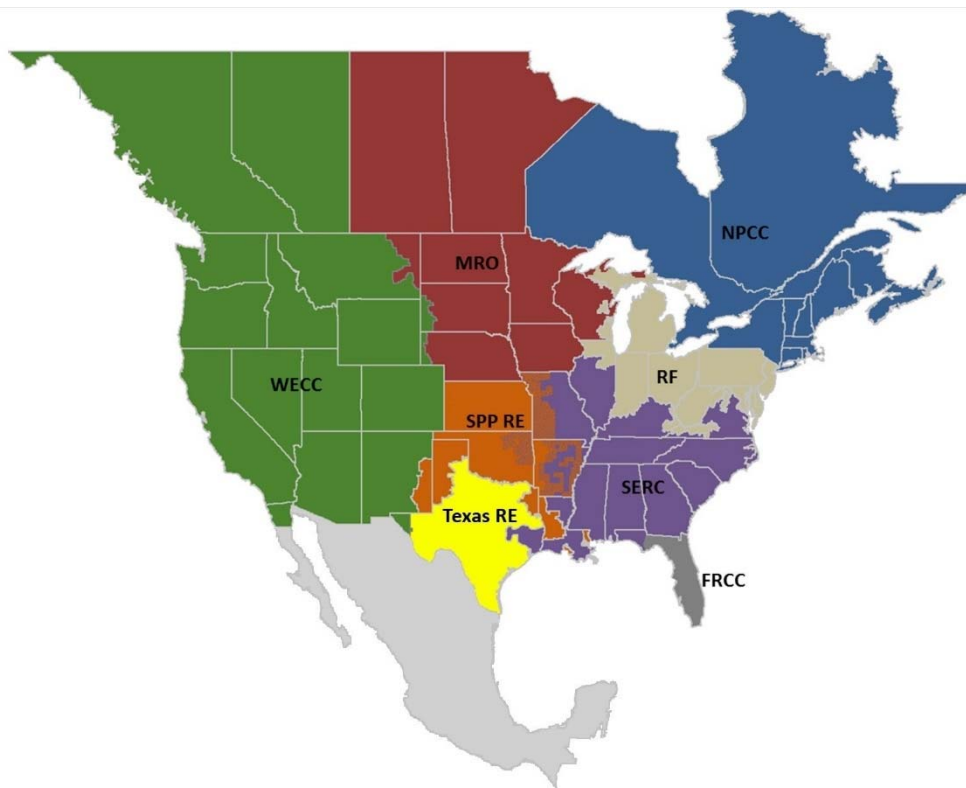
Preface.....	iii
Introduction.....	iv
Background.....	iv
General Characteristics.....	iv
Supplemental GMD Event Description.....	1
Supplemental GMD Event Geoelectric Field Amplitude.....	1
Supplemental Geomagnetic Field Waveform.....	1
Appendix I – Technical Considerations.....	3
Statistical Considerations.....	3
Extreme Value Analysis.....	3
Spatial Considerations.....	7
Local Enhancement Waveform.....	13
Transformer Thermal Assessment.....	15
Appendix II – Scaling the Supplemental GMD Event.....	16
Scaling the Geomagnetic Field.....	16
Scaling the Geoelectric Field.....	17
References.....	21

## Preface

---

The North American Electric Reliability Corporation (NERC) is a not-for-profit international regulatory authority whose mission is to assure the reliability and security of the bulk power system (BPS) in North America. NERC develops and enforces Reliability Standards; annually assesses seasonal and long-term reliability; monitors the BPS through system awareness; and educates, trains, and certifies industry personnel. NERC’s area of responsibility spans the continental United States, Canada, and the northern portion of Baja California, Mexico. NERC is the Electric Reliability Organization (ERO) for North America, subject to oversight by the Federal Energy Regulatory Commission (FERC) and governmental authorities in Canada. NERC’s jurisdiction includes users, owners, and operators of the BPS, which serves more than 334 million people.

The North American BPS is divided into eight Regional Entity (RE) boundaries as shown in the map and corresponding table below.



*The North American BPS is divided into eight RE boundaries. The highlighted areas denote overlap as some load-serving entities participate in one Region while associated transmission owners/operators participate in another.*

<b>FRCC</b>	Florida Reliability Coordinating Council
<b>MRO</b>	Midwest Reliability Organization
<b>NPCC</b>	Northeast Power Coordinating Council
<b>RF</b>	ReliabilityFirst
<b>SERC</b>	SERC Reliability Corporation
<b>SPP RE</b>	Southwest Power Pool Regional Entity
<b>Texas RE</b>	Texas Reliability Entity
<b>WECC</b>	Western Electricity Coordinating Council

# Introduction

---

## Background

Proposed TPL-007-2 includes requirements for entities to perform two types of geomagnetic disturbance (GMD) Vulnerability Assessments to evaluate the potential impacts of GMD events on the Bulk Electric System (BES):

- The benchmark GMD Vulnerability Assessment is based on the benchmark GMD event associated with TPL-007-1, which was approved by the FERC Order No. 830 in September 2016. The benchmark GMD event is derived from spatially-averaged geoelectric field values to address potential wide-area effects that could be caused by a severe 1-in-100 year GMD event.<sup>1</sup>
- The supplemental GMD Vulnerability Assessment, based on the supplemental GMD event described in this white paper, is used by entities to evaluate localized enhancements of geomagnetic field during a severe GMD event that "could potentially affect the reliable operation of the Bulk-Power System."<sup>2</sup> Localized enhancements of geomagnetic field can result in geoelectric field values above the spatially-averaged benchmark in a local area.

The purpose of the supplemental GMD event description is to provide a defined event for assessing system performance for a GMD event which includes a local enhancement of the geomagnetic field. In addition to varying with time, geomagnetic fields can be spatially non-uniform with higher and lower strengths across a region. This spatial non-uniformity has been observed in a number of GMD events, so localized enhancement of field strength above the average value is considered. The supplemental GMD event defines the geomagnetic and geoelectric field values used to compute geomagnetically-induced current (GIC) flows for a supplemental GMD Vulnerability Assessment.

## General Characteristics

The supplemental GMD event described herein takes into consideration observed characteristics of a local geomagnetic field enhancement, recognizing that the science and understanding of these events is evolving. Based on observations and initial assessments, the characteristics of local enhancements include:

- Geographic area – The extent of local enhancements is on the order of 100km in North-South (latitude) direction but longer in East-West (longitude) direction. Further description of the geographic area is provided later in the white paper.
- Amplitude – The amplitude of the resulting geoelectric field is significantly higher than the geoelectric field that is calculated in the spatially-averaged Benchmark GMD event.
- Duration – The local enhancement in the geomagnetic field occurs over a time period of two to five minutes.
- Geoelectric field waveform – The supplemental GMD event waveform is the benchmark GMD event waveform with the addition of a local enhancement. The added local enhancement has amplitude and duration characteristics described above. The geoelectric field waveform has a strong influence on the hot spot heating of transformer windings and structural parts since thermal time constants of the transformer and time to peak of storm maxima are both on the order of minutes. The frequency content of the rate of change of the magnetic field (dB/dt) is a function of the waveform, which in turn has a direct effect on the geoelectric field since the earth response to dB/dt is frequency-dependent. As with the

---

<sup>1</sup> See *Benchmark Geomagnetic Disturbance Event Description* white paper, May 12, 2016. Filed by NERC in RM 15-11 on June 28, 2016.

<sup>2</sup> See FERC Order No. 830, P. 47. In Order 830, FERC directed NERC to develop modifications to the benchmark GMD event, included in TPL-007-1, such that assessments would not be based solely on spatially averaged data.

benchmark GMD event, the supplemental GMD event waveform is based on magnetic field data recorded by the Natural Resources Canada (NRCan) Ottawa (OTT) geomagnetic observatory during the March 13-14, 1989 event. This GMD event data was selected because analysis of recorded events indicates that the OTT observatory data for this period provides conservative results when performing thermal assessments of power transformers.<sup>3</sup>

---

<sup>3</sup> See *Benchmark Geomagnetic Disturbance Event Description* white paper, page 5 and Appendix I.



# Supplemental GMD Event Description

---

Severe GMD events are high-impact, low-frequency (HILF) events [1]; thus, GMD events used in system planning should consider the probability that the event will occur, as well as the impact or consequences of such an event. The supplemental GMD event is composed of the following elements: 1) a reference peak geoelectric field amplitude (V/km) derived from statistical analysis of historical magnetometer data; 2) scaling factors to account for local geomagnetic latitude; 3) scaling factors to account for local earth conductivity; and 4) a reference geomagnetic field time series or waveform to facilitate time-domain analysis of GMD impact on equipment.

## Supplemental GMD Event Geoelectric Field Amplitude

The supplemental GMD event field amplitude was determined through statistical analysis using the plane wave method [2]-[9] of geomagnetic field measurements from geomagnetic observatories in northern Europe [10] and the North American (i.e., Québec) reference earth model shown in Table 1 [11], supplemented by data from Greenland, Denmark and United States (i.e., Alaska). For details of the statistical considerations, see Appendix I. The Québec earth model is generally resistive and the geological structure is relatively well understood.

Thickness (km)	Resistivity ( $\Omega\text{-m}$ )
15	20,000
10	200
125	1,000
200	100
$\infty$	3

The statistical analysis (see Appendix I) resulted in conservative peak geoelectric field amplitude of approximately 12 V/km. For steady-state GIC and load flow analysis, the direction of the geoelectric field is assumed to be variable meaning that it can be in any direction (Eastward, Northward, or a vectorial combination thereof).

The regional geoelectric field peak amplitude,  $E_{peak}$ , to be used in calculating GIC in the GIC system model can be obtained from the reference value of 12 V/km using the following relationship

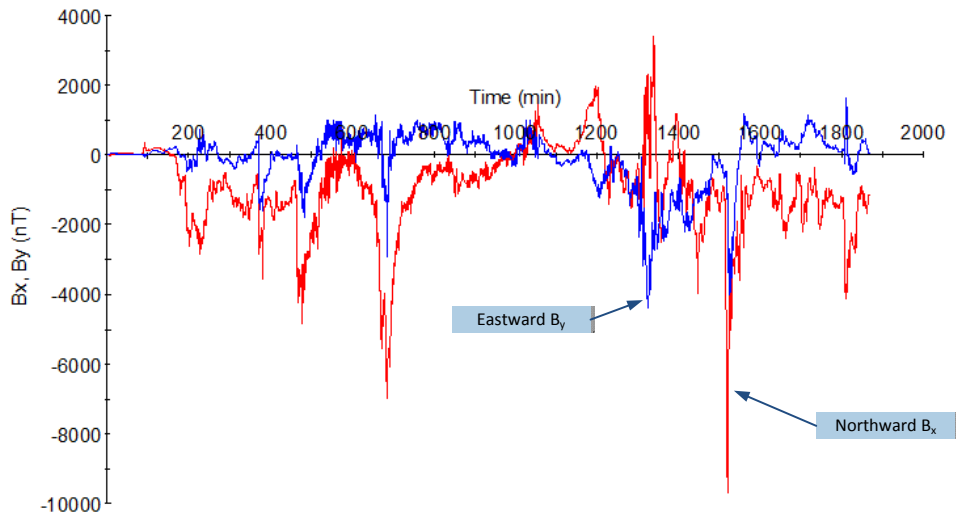
$$E_{peak} = 12 \times \alpha \times \beta_s \text{ (V/km)} \tag{1}$$

where  $\alpha$  is the scaling factor to account for local geomagnetic latitude, and  $\beta_s$  is a scaling factor for the supplemental GMD event to account for the local earth conductivity structure (see Appendix II).

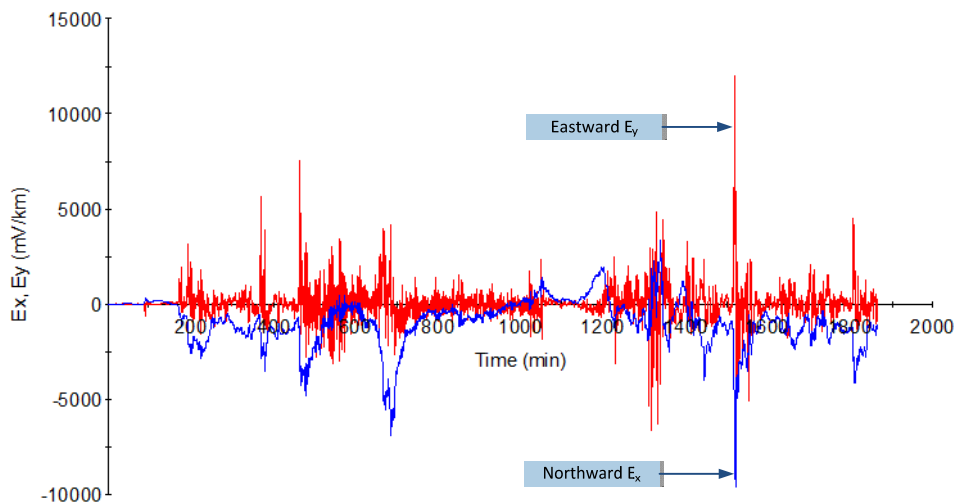
## Supplemental Geomagnetic Field Waveform

The supplemental geomagnetic field waveform is the benchmark geomagnetic field waveform with the addition of a local enhancement. Both the benchmark and supplemental geomagnetic field waveforms are used to calculate the GIC time series,  $GIC(t)$ , required for transformer thermal impact assessments. The supplemental waveform includes a local enhancement, inserted at UT 1:18 March 14, 1989 in Figure 1 below. This time corresponds to the largest calculated geoelectric fields during the benchmark GMD event. The amplitude of the local enhancement is based on a statistical analysis of a number of GMD events, discussed in Appendix I. The duration of the enhancement is based on the characteristics of observed localized enhancements as discussed in Appendix I.

The geomagnetic latitude of the Ottawa geomagnetic observatory is 55°; therefore, the amplitude of the geomagnetic field measurement data with a local enhancement was scaled up to the 60° reference geomagnetic latitude (see Figure 1) such that the resulting peak geoelectric field amplitude computed using the reference earth model was 12 V/km (see Figure 2). Sampling rate for the geomagnetic field waveform is 10 seconds.



**Figure 1: Supplemental Geomagnetic Field Waveform**  
 Red  $B_x$  (Northward), Blue  $B_y$  (Eastward), Referenced to pre-event quiet conditions



**Figure 2: Supplemental Geoelectric Field Waveform**  
 Red  $E_y$  (Eastward) and Blue  $E_x$  (Northward)

## Appendix I – Technical Considerations

---

The following sections describe the technical justification of the assumptions that were made in the development of the supplemental GMD event.

### Statistical Considerations

The peak geoelectric field amplitude of the supplemental GMD event was determined through statistical analysis of modern 10-second geomagnetic field data and corresponding calculated geoelectric field amplitudes. The objective of the analysis was to estimate the geoelectric field amplitude that is associated with a 1 in 100 year frequency of occurrence. The same data set and similar statistical techniques were used in determining the peak geoelectric field amplitude of the benchmark GMD event, including extreme value analysis discussed in the following section.<sup>4</sup> The fundamental difference in the supplemental GMD event amplitude is that it is based on observations taken at each individual station (i.e., localized measurements), in contrast with the spatially averaged geoelectric fields used in the *Benchmark Geomagnetic Disturbance Event Description* white paper.<sup>5</sup>

### Extreme Value Analysis

The objective of extreme value analysis is to describe the behavior of a stochastic process at extreme deviations from the median. In general, the intent is to quantify the probability of an event more extreme than any previously observed. In particular, we are concerned with estimating the 95% confidence interval of the maximum geoelectric field amplitude to be expected within a 100-year return period.<sup>6</sup>

The data set consists of 23 years of daily maximum geoelectric field amplitudes derived from individual stations<sup>7</sup> in the IMAGE magnetometer chain, using the Québec earth model as a reference. Figure I-1 shows a scatter plot of geoelectric field amplitudes that exceed 2 V/km across the IMAGE stations. The plot indicates that there is seasonality in extreme observations associated with the 11-year solar cycle.

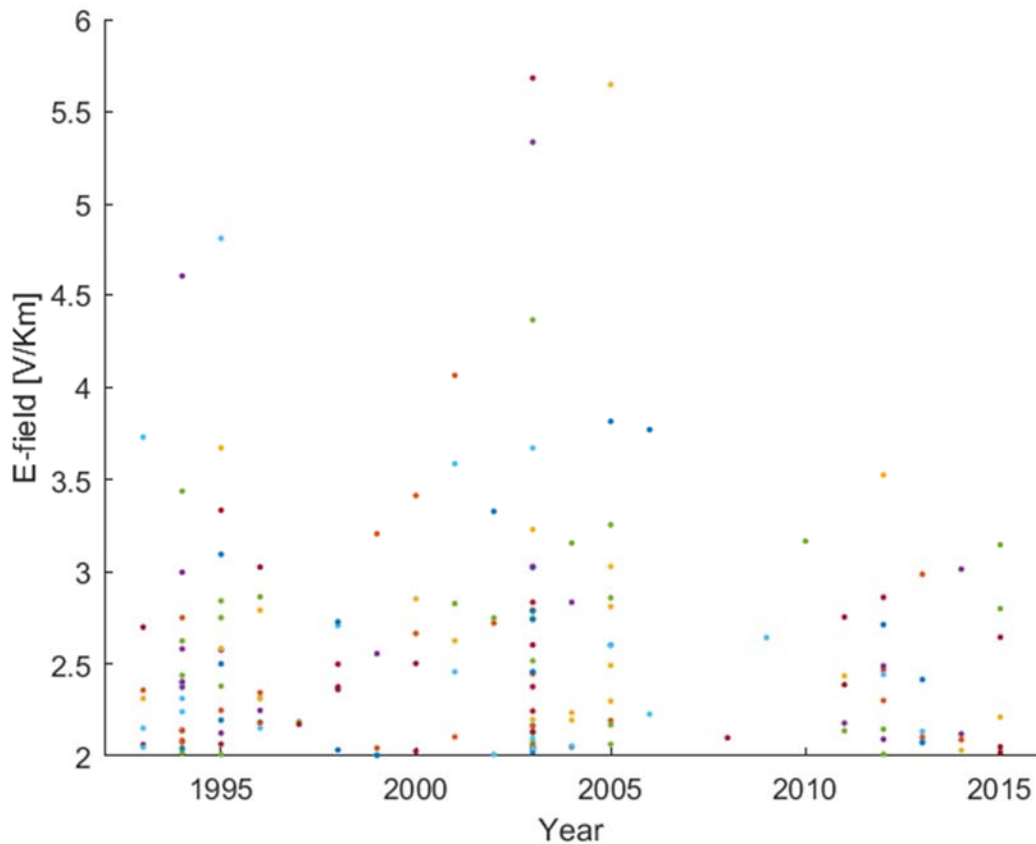
---

<sup>4</sup> See *Benchmark Geomagnetic Disturbance Event Description* white paper, Appendix I, pages 8-13.

<sup>5</sup> Averaging the geoelectric field values of stations in geographic groups is referred to as spatial averaging in the *Benchmark Geomagnetic Disturbance Event Description*. Spatial averaging was used to characterize GMD events over a geographic area relevant to the interconnected transmission system for purposes of assessing area effects such as voltage collapse and widespread equipment risk. See *Benchmark Geomagnetic Disturbance Event Description* white paper, Appendix I, pages 9-10.

<sup>6</sup> A 95 percent confidence interval means that, if repeated samples were obtained, the return level would lie within the confidence interval for 95 percent of the samples.

<sup>7</sup> US – <https://geomag.usgs.gov/>; Canada – <http://geomag.nrcan.gc.ca/lab/default-en.php>.



**Figure I-1: Scatter Plot of Geoelectric Fields that Exceed a 2 V/km Threshold**

Data source [11]: IMAGE magnetometer chain from 1993-2015.

Several statistical methods can be used to conduct extreme value analysis. The most commonly applied include: Generalized Extreme Value (GEV), Point Over Threshold (POT), R-Largest, and Point Process (PP). In general, all methods assume independent and identically distributed (iid) data [12].

Table I-1 shows a summary of the estimated parameters and return levels obtained from different statistical methods. The parameters were estimated using the Maximum Likelihood Estimator (MLE). Since the distribution parameters do not have an intuitive interpretation, the expected geoelectric field amplitude for a 100-year return period is also included in Table I-1. The 95% confidence interval of the 100-year return level was calculated using the delta method and the profile likelihood. The delta method relies on the Gaussian approximation to the distribution of the MLE; this approximation can be poor for long return periods. In general, the profile likelihood provides a better description of the return level.

Table I-1: Extreme Value Analysis					
Statistical Model	Estimated Parameters	Hypothesis Testing	100 Year Return Level		
			Mean [V/km]	95% CI Delta [V/km]	95% CI P-Likelihood [V/km]
(1) GEV	$\mu=2.976$ (0.193)  $\sigma=0.829$ (0.1357)  $\xi=-0.0655$ (0.1446)	$H_0: \xi=0$ $p = 0.66$	6.9	[4.3, 8.2]	[5.2, 11.4]
(2) GEV, reparametrization $\mu = \beta_0 + \beta_1 \times \sin\left(\frac{t}{T} + \phi\right)$	$\beta_0= 2.964$ (0.151)  $\beta_1=0.582$ (0.155)  $\sigma=0.627$ (0.114)  $\xi=0.09$ (0.183)	$H_0: \beta_1=0$ $p = 0.00$  $H_0: \xi=0$ $p = 0.6$	7.1	[4, 10.2]	[5.5, 18]
(3) POT, threshold=2 V/km 3 day decluster. 143 observations > 2V/km.	$\sigma=0.592$ (0.074)  $\xi=0.077$ (0.093)		6.9	[4.5, 9.4]	[5.4, 11.9]
(4) POT, threshold=2V/km reparametrization, $\sigma = \beta_0 + \beta_1 \times \sin\left(\frac{t}{T} + \phi\right)$	$\beta_0=0.58$ (0.073)  $\beta_1=0.107$ (0.082)  $\xi=0.037$ (0.097)	$H_0: B_1=0$ $p = 0.2$	7	[4.6, 9.3]	[5.5, 11.7]

Statistical model (1) in Table I-1 is the traditional GEV estimation using blocks of one year maxima; i.e., only 23 data points are used in the estimation. The mean expected amplitude of the geoelectric field for a 100-year return level is approximately 7 V/km. Since GEV works with blocks of maxima, it is typically regarded as a wasteful approach.

As discussed previously, GEV assumes that the data is iid. Based on the scatter plot shown in Figure I-1, the iid statistical assumption is not warranted by the data. Statistical model (2) in Table I-1 is a reparametrization of the GEV distribution contemplating the 11-year seasonality in the mean,

$$\mu = \beta_0 + \beta_1 \times \sin\left(\frac{t}{T} + \phi\right)$$

where  $\beta_0$  represents the offset in the mean,  $\beta_1$  describes the 11-year seasonality,  $T$  is the period (11 years), and  $\phi$  is a constant phase shift.

A likelihood ratio test is used to test the hypothesis that  $\beta_1$  is zero. The null hypothesis,  $H_0: \beta_1=0$ , is rejected with a p-value of 0.0032; as expected, the 11-year seasonality has explanatory power. The blocks of maxima during the solar minimum are better represented in the reparametrized GEV. The mean return level is still 7 V/km, but the confidence interval is wider, [5.5, 18] V/km for the profile likelihood (calculated at solar maximum).

Statistical model (3) in Table I-1 is the traditional POT estimation using a threshold  $u$  of 2 V/km; the data was declustered using a 1-day run. The data set consists of normalized excesses over a threshold, and therefore, the sample size for POT is increased if more than one extreme observation per year is available (in the GEV approach, only the maximum observation over the year was taken; in the POT method, a single year can have multiple observations over the threshold). The selection of the threshold  $u$  is a compromise between bias and variance. The asymptotic basis of the model relies on a high threshold; too low a threshold will likely lead to bias. On the other hand, too high a threshold will reduce the sample size and result in high variance. A threshold of 2V/km was determined to be a good choice, giving rise to 143 observations above the threshold.

The mean return level for statistical model (3),  $\sim 7$  V/km, is consistent with the GEV estimates. However, due to the larger sample size the POT method is more efficient rendering a confidence interval of [5.4, 11.9] V/km for the profile likelihood method.

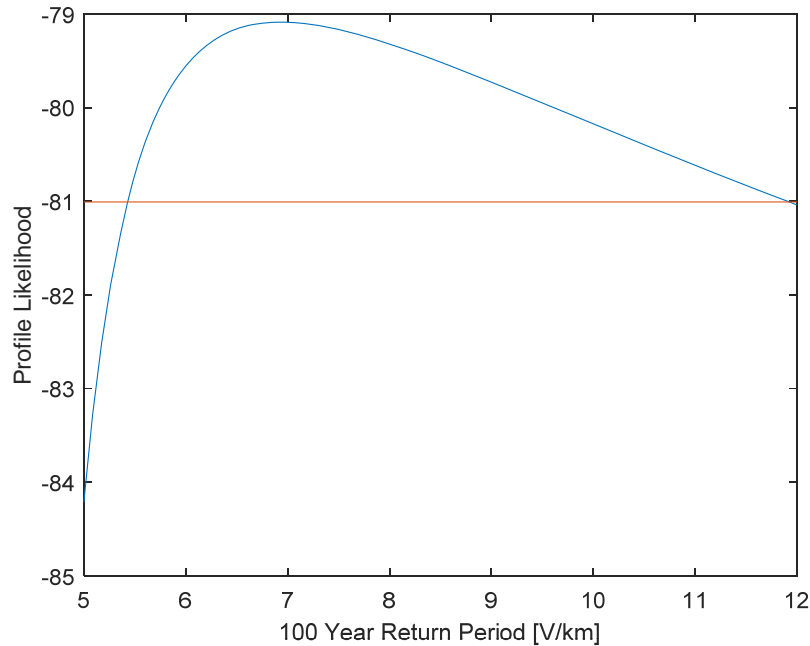
In an attempt to cope with potential heteroskedasticity in the data, a reparametrization of POT is proposed in statistical model (4) in Table I-1,

$$\sigma = \alpha_0 + \alpha_1 \times \sin\left(\frac{t}{T} + \phi\right)$$

where  $\alpha_0$  represents the offset in the standard deviation,  $\alpha_1$  describes the 11-year seasonality,  $T$  is the period ( $365.25 \cdot 11$ ), and  $\phi$  is a constant phase shift.

The parameter  $\alpha_1$  is not statistically significant; the null hypothesis,  $H_0: \alpha_1=0$ , is not rejected with a p-value of 0.2. The proposed reparametrization does not have explanatory power, and consequently, the mean return level 7 V/km and confidence intervals remain virtually unchanged [5.5, 11.7]. As a final remark, it is emphasized that the confidence interval obtained using the profile likelihood is preferred over the delta method.

Figure I-2 shows the profile likelihood of the 100-year return level of statistical model (3). Note that the profile likelihood is highly asymmetric with a positive skew, rendering a larger upper limit for the confidence interval. Recall that the delta method assumes a normal distribution for the MLEs, and therefore, the confidence interval is symmetric around the mean.



**Figure I-2: Profile Likelihood for 100-year Return Level for Statistical Model (3)**

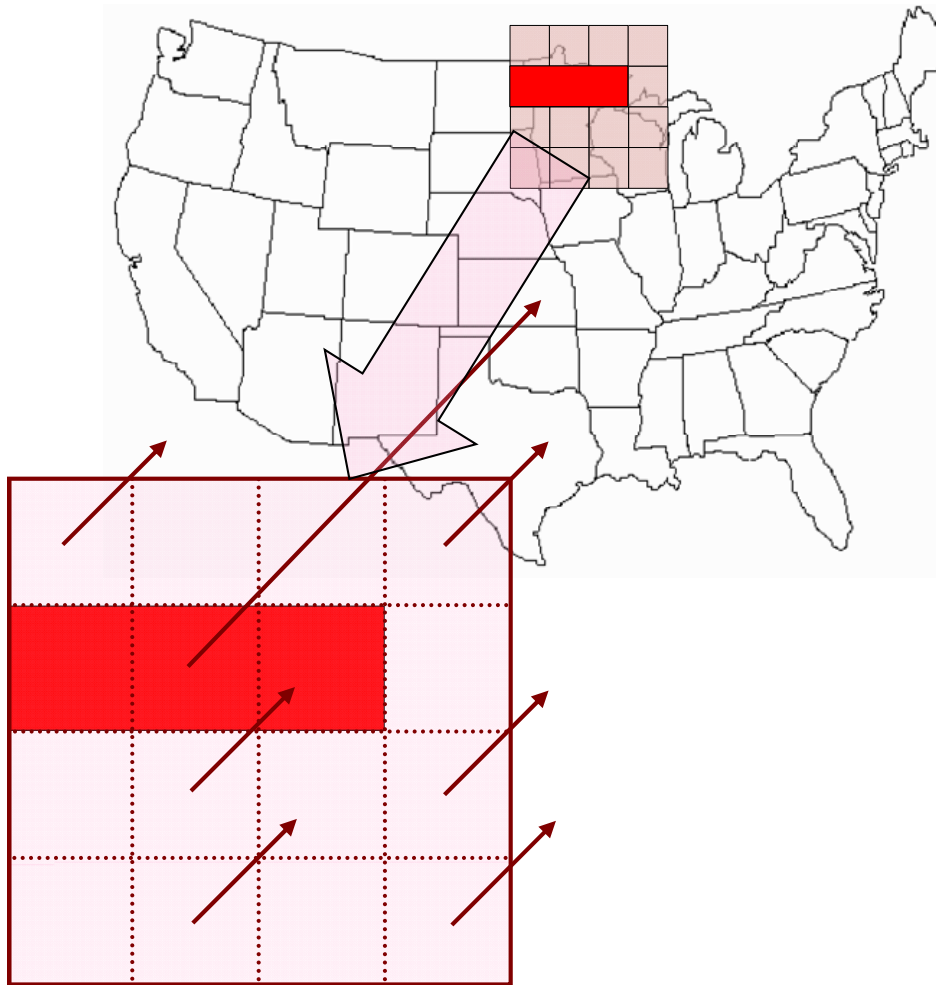
To conclude, the traditional GEV (1) is misspecified; the statistical assumptions (i.e., iid) are not warranted by the data. The model was reparametrized to cope with seasonality in the data. Statistical models (3) and (4) better utilize the available extreme measurements and they are therefore preferred over statistical model (2). A geoelectric field amplitude of 12 V/km is selected for the supplemental GMD event to represent the upper limit of the 95 percent confidence interval for a 100-year return interval.

## Spatial Considerations

The spatial structure of high-latitude geomagnetic fields can be very complex during strong geomagnetic storm events [13]-[14]. One reflection of this spatial complexity is localized geomagnetic field enhancements (local enhancements) that result in high amplitude geoelectric fields in regions of a few hundred kilometers. Figure I-3 illustrates this spatial complexity of the storm-time geoelectric fields.<sup>8</sup> In areas indicated by the bright red location, the geoelectric field can be substantially larger than at neighboring locations. These enhancements are primarily the result of external (geomagnetic field) conditions, and not local geological factors such as coastal effects.<sup>9</sup>

<sup>8</sup> Figure I-3 is for illustration purposes only, and is not meant to suggest that a particular area is more likely to experience a localized enhanced geoelectric field. The depiction is not to scale.

<sup>9</sup> Localized externally-driven geomagnetic phenomena should not be confused with localized geoelectric field enhancements due to complex electromagnetic response of the ground to external excitation. Complex 3D geological conditions such as those at coastal regions can lead to localized geoelectric field enhancements but those are not considered here.



**Figure I-3: Illustration of the Spatial Scale between Localized Enhancements and Larger Spatial Scale Amplitudes of Goelectric Field during a Strong Geomagnetic Storm**

In this figure, the red rectangle illustrates a spatially localized field enhancement.

The supplemental GMD event is designed to address local effects caused by a severe GMD event, such as increased var absorption and voltage depressions.

A number of GMD events were analyzed to identify the basic characteristics of local enhancements. Three (3) solar storms studied and described below are:

- March 13, 1989
- October 29-30, 2003
- March 17, 2015

Four localized events within those storms were identified and analyzed. Geomagnetic field recordings were collected for these storms and the goelectric field was computed using the 1D plane wave method and the reference Québec ground model. In each case, a local enhancement was correlated, generally oriented parallel to the westward ionospheric electrojet associated with ongoing larger scale geomagnetic activity. (See Figures I-4 – I-7 below).



Goelectric field distribution 0089-03-13T21:44:00 UT. Max. IEI: 5.90 V/km.

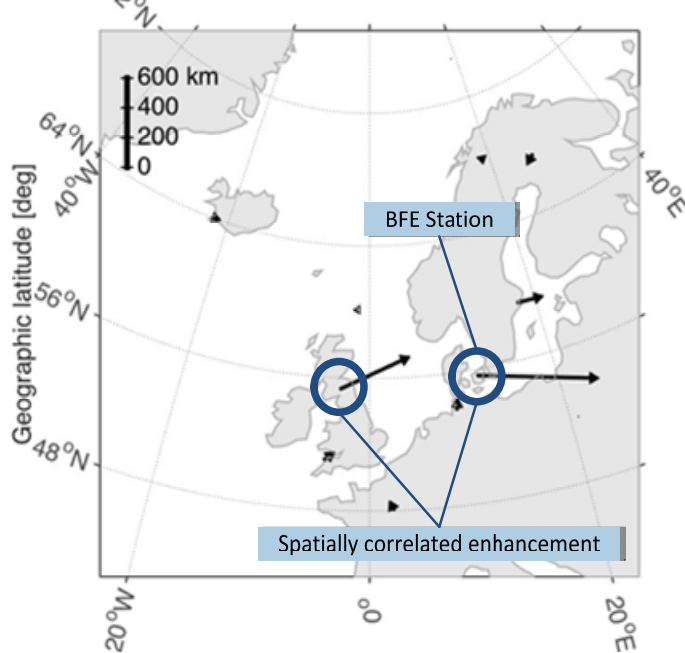


Figure I-4: March 13, 1989, at 21:44 UT, Brorfelde (BFE), Denmark

Goelectric field distribution 2003-10-29T06:47:20 UT. Max. IEI: 9.31 V/km.

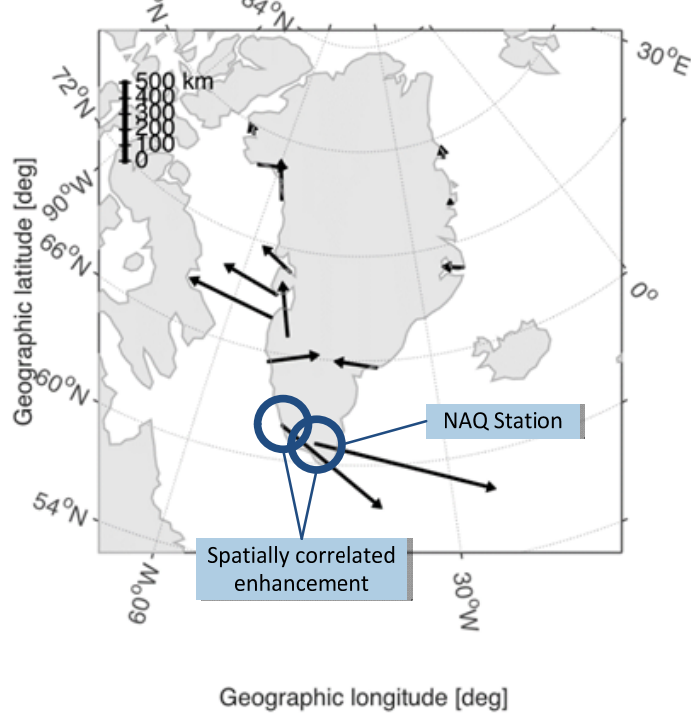


Figure I-5: October 29, 2003, at 06:47 UT, Narsarsuaq (NAQ), Greenland

Goelectric field distribution 2003-10-30T16:49:30 UT. Max. IEI: 5.68 V/km.

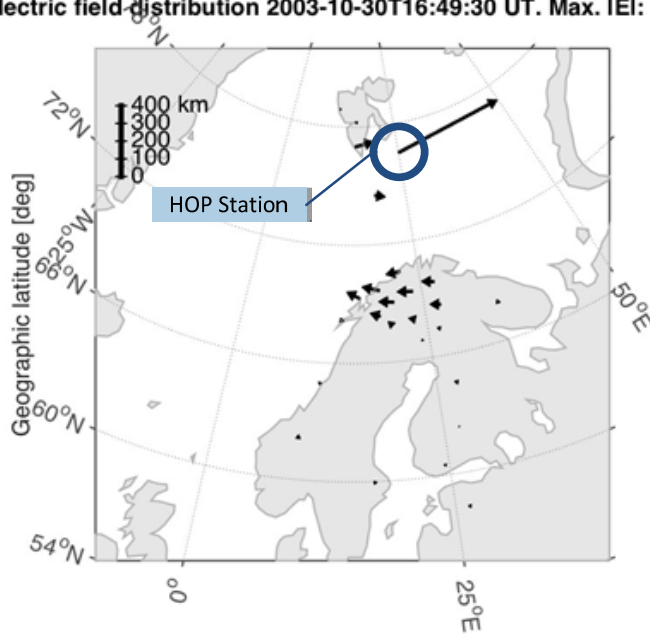


Figure I-6: October 30, 2003, at 16:49UT, Hopen Island (HOP), Svalbard, Norway

Goelectric field distribution 2015-03-17T13:33:00 UT. Max. IEI: 3.46 V/km.

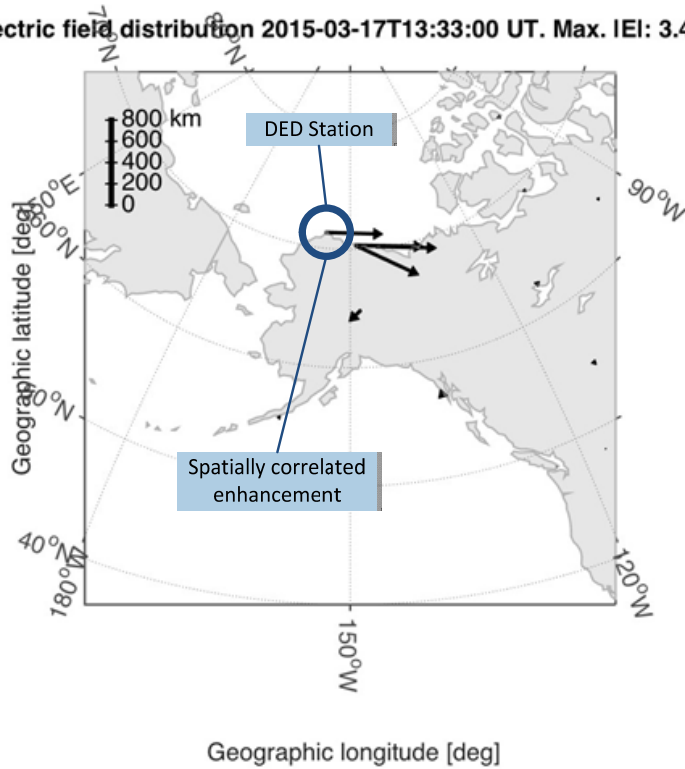


Figure I-7: March 17, 2015, at 13:33 UT, Deadhorse, Alaska, USA

All of the above events were analyzed by reviewing the time series magnetic field data and transforming it to an electric field and focusing on the time period of the spatially correlated local enhancement. There were apparent similarities in the character of the local enhancements. The local enhancements occurred during peak periods of geomagnetic activity and were distinguished by relatively brief excursions of rapid magnetic field variation. With respect to time duration, the local enhancements generally occurred over a period of 2-5 minutes. (See Figures I-8 – I-11)

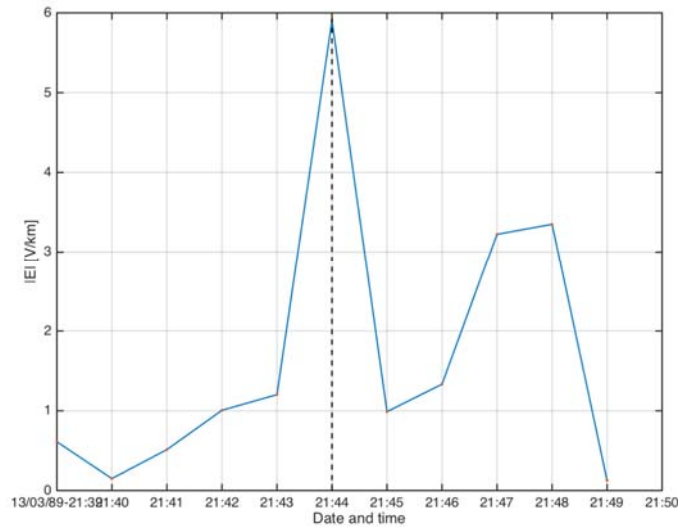


Figure I-8: Geoelectric field March 13, 1989, at 21:44 UT, Brorfelde (BFE), Denmark

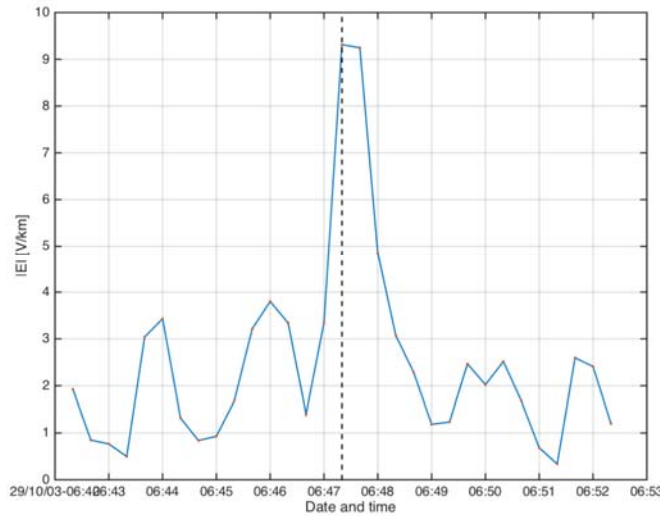
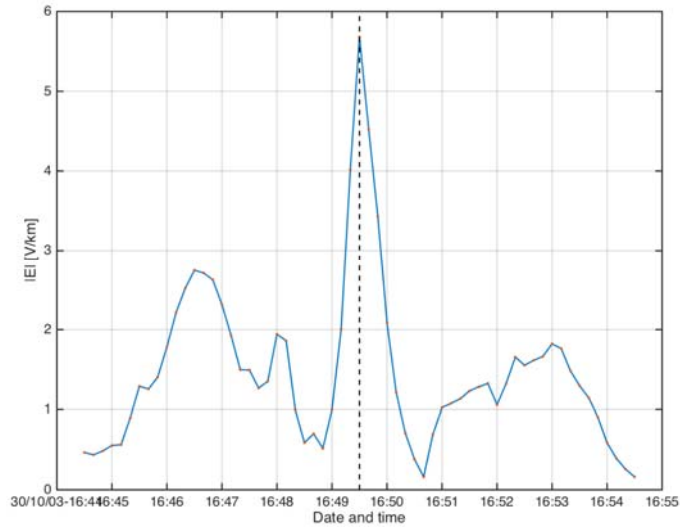
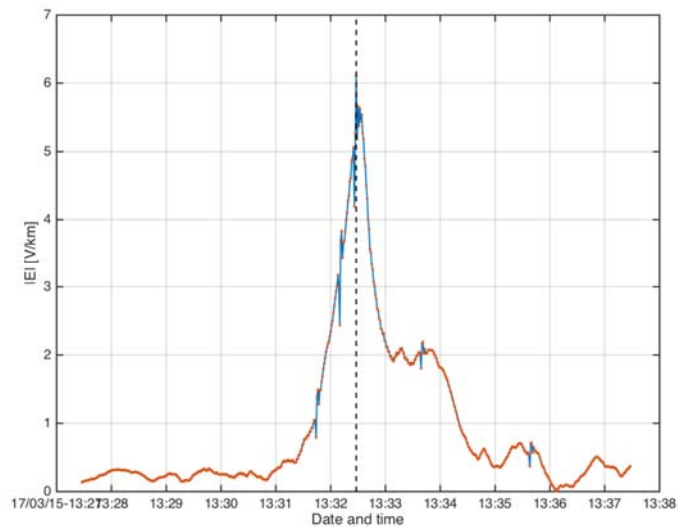


Figure I-9: Geoelectric field October 29, 2003, at 06:47 UT, Narsarsuaq (NAQ), Greenland



**Figure I-10: Geoelectric field October 30, 2003, at 16:49 UT, Hopen Island (HOP), Norway**



**Figure I-11 – Geoelectric field March 17, 2015, at 13:33 UT, Deadhorse, Alaska, USA**

Based on the above analysis and the previous work associated with the benchmark GMD event, it is reasonable to incorporate a second (or supplemental) assessment into TPL-007-2 to account for the potential impact of a local enhancement in both the network analysis and the transformer thermal assessment(s).

With respect to geographic area of the localized enhancement, the historical geomagnetic field data analyzed so far provides some insight. Analysis suggests that the enhancements will occur in a relatively narrow band of geomagnetic latitude (on the order of 100 km) and wider longitudinal width (on the order of 500 km) as a consequence of the westward-oriented structure of the source in the ionosphere.

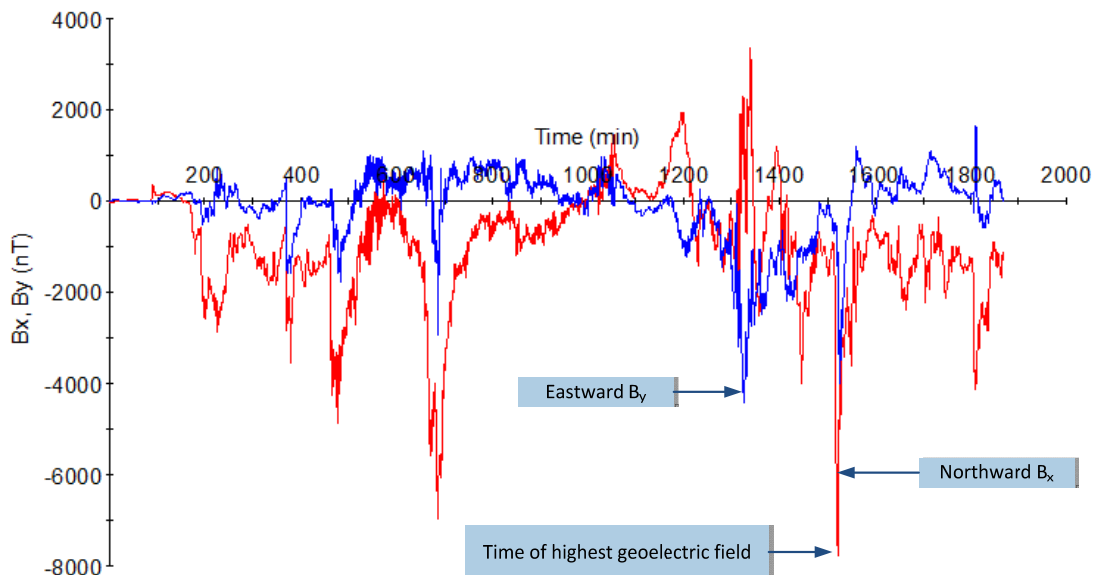
Proposed TPL-007-2 provides flexibility for planners to determine how to apply the supplemental GMD event to the planning area. Acceptable approaches include, but are not limited to:

- Applying the peak geoelectric field for the supplemental GMD event (12 V/km scaled to the planning area) over the entire planning area;
- Applying a spatially limited (e.g., 100 km in North-South direction and 500 km in East-West direction) geoelectric field enhancement (12 V/km scaled to the planning area) over a portion(s) of the system, and applying the benchmark GMD event over the rest of the system.
- Other methods to adjust the benchmark GMD event analysis for localized geoelectric field enhancement.

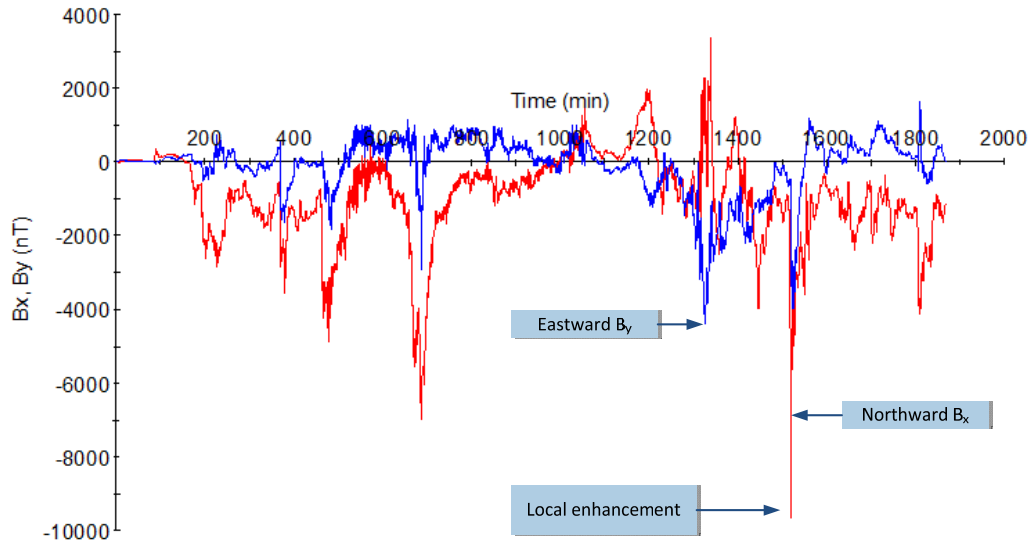
Given the current state of knowledge regarding the spatial extent of a local geomagnetic field enhancements, upper geographic boundaries, such as the values used in the approaches above, are reasonable but are not definitive.

## Local Enhancement Waveform

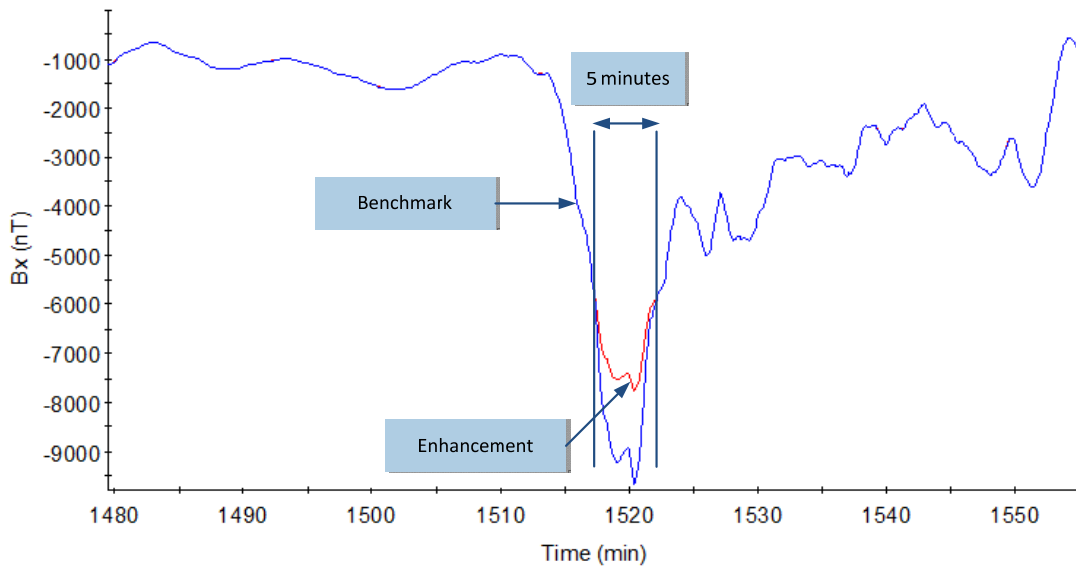
The supplemental geomagnetic field waveform was derived by modifying the benchmark GMD event waveform to emulate the observed events described above. The temporal location of the enhancement corresponds to the time of the benchmark event with the highest geoelectric field. The local enhancement was constructed by scaling linearly a 5-minute portion of the benchmark geomagnetic field so that the peak geoelectric field is 12 V/km at a geomagnetic latitude of  $60^\circ$  and reference earth model. Figure I-12 shows the benchmark geomagnetic field and Figure I-13 shows the supplemental event geomagnetic field. Figure I-14 expands the view into  $B_x$ , with and without the local enhancement. Figure I-15 is the corresponding expanded view of the geoelectric field magnitude with and without the local enhancement.



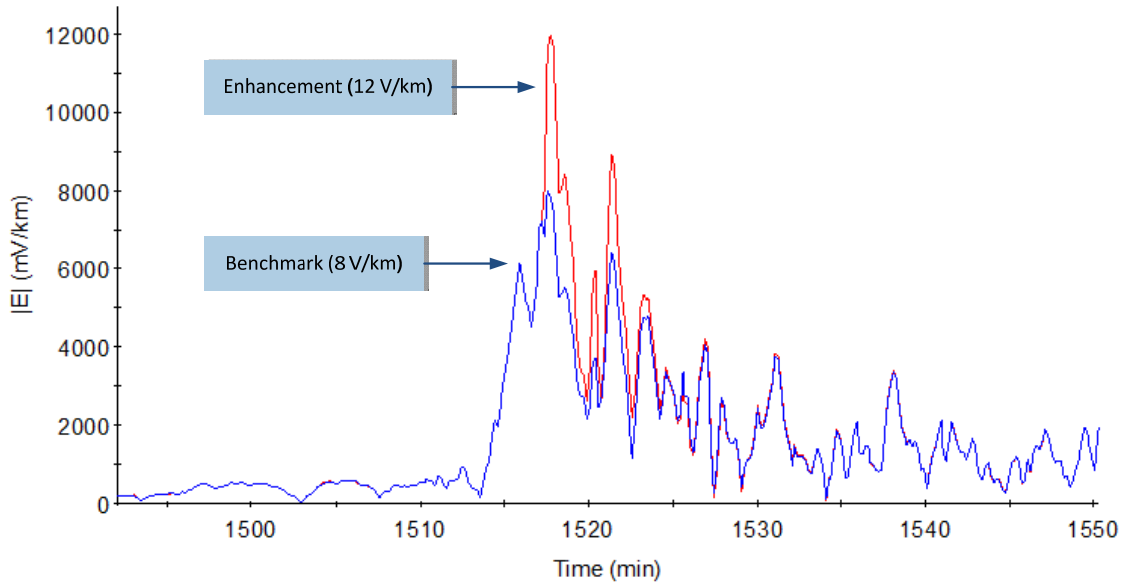
**Figure I-12: Benchmark Geomagnetic Field**  
Red  $B_x$  (Northward), Blue  $B_y$  (Eastward)



**Figure I-13: Supplemental Geomagnetic Field Waveform  
Red  $B_x$  (Northward), Blue  $B_y$  (Eastward)**



**Figure I-14: Red Benchmark  $B_x$  and Blue Supplemental  $B_x$  (Northward) – Expanded View**



**Figure I-15: Magnitude of the Geoelectric Field  
Benchmark Blue and Supplemental Red – Expanded View**

## Transformer Thermal Assessment

The local enhancement of the supplemental GMD event waveform can have a material impact on the temperature rise (hot-spot heating or metallic parts) even though the duration of the local enhancement is approximately five minutes. Thermal assessments based on the supplemental GMD event can be performed using the same methods employed for benchmark thermal assessments.<sup>10</sup>

<sup>10</sup> See Transformer Thermal Impact Assessment white paper: <http://www.nerc.com/pa/Stand/Pages/Project-2013-03-Geomagnetic-Disturbance-Mitigation.aspx>.

## Appendix II – Scaling the Supplemental GMD Event

The intensity of a GMD event depends on geographical considerations such as geomagnetic latitude and local earth conductivity [2].<sup>11</sup> Scaling factors for geomagnetic latitude take into consideration that the intensity of a GMD event varies according to latitude-based geographical location. Scaling factors for earth conductivity take into account that the induced geoelectric field depends on earth conductivity, and that different parts of the continent have different earth conductivity and deep earth structure.

Scaling the supplemental GMD event differs from the benchmark GMD event in two ways:

- $E_{\text{peak}}$  is 12 V/km instead of 8 V/km
- Beta factors for scaling the geoelectric field based on earth conductivity are different (see Table II-2)

More discussion, including example calculations, is contained in the Benchmark GMD Event Description white paper.

### Scaling the Geomagnetic Field

The supplemental GMD event is defined for geomagnetic latitude of 60° and it must be scaled to account for regional differences based on geomagnetic latitude. To allow usage of the supplemental geomagnetic field waveform in other locations, Table II-1 summarizes the scaling factor  $\alpha$  correlating peak geoelectric field to geomagnetic latitude as illustrated in Figure II-1 [3]. This scaling factor  $\alpha$  has been obtained from a large number of global geomagnetic field observations of all major geomagnetic storms since the late 1980s [15]-[17], and can be approximated with the empirical expression in (II.1):

$$\alpha = 0.001 \times e^{(0.115 \times L)} \quad (\text{II.1})$$

where  $L$  is the geomagnetic latitude in degrees and  $0.1 \leq \alpha \leq 1.0$ .

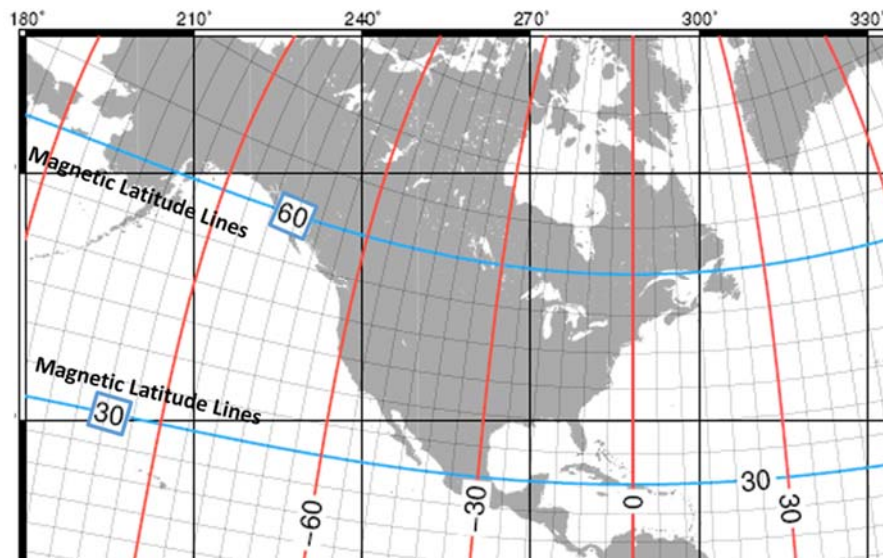


Figure II-1: Geomagnetic Latitude Lines in North America

<sup>11</sup> Geomagnetic latitude is analogous to geographic latitude, except that bearing is in relation to the magnetic poles, as opposed to the geographic poles. Geomagnetic phenomena are often best organized as a function of geomagnetic coordinates. Local earth conductivity refers to the electrical characteristics to depths of hundreds of km down to the earth's mantle. In general terms, lower ground conductivity results in higher geoelectric field amplitudes.



Table II-1: Geomagnetic Field Scaling Factors	
Geomagnetic Latitude (Degrees)	Scaling Factor1 ( $\alpha$ )
$\leq 40$	0.10
45	0.2
50	0.3
54	0.5
56	0.6
57	0.7
58	0.8
59	0.9
$\geq 60$	1.0

## Scaling the Goelectric Field

The supplemental GMD event is defined for the reference Québec earth model provided in Table 1. This earth model has been used in many peer-reviewed technical articles [11, 15]. The peak goelectric field depends on the geomagnetic field waveform and the local earth conductivity. Ideally, the peak goelectric field,  $E_{peak}$ , is obtained by calculating the goelectric field from the scaled geomagnetic field waveform using the plane wave method and taking the maximum value of the resulting waveforms:

$$\begin{aligned}
 E_N &= (z(t)/\mu_0)^* \times B_E(t) \\
 E_N &= -(z(t)/\mu_0)^* \times B_N(t) \\
 E_{peak} &= \max\{|E_E(t), E_N(t)|\}
 \end{aligned}
 \tag{II.2}$$

where,

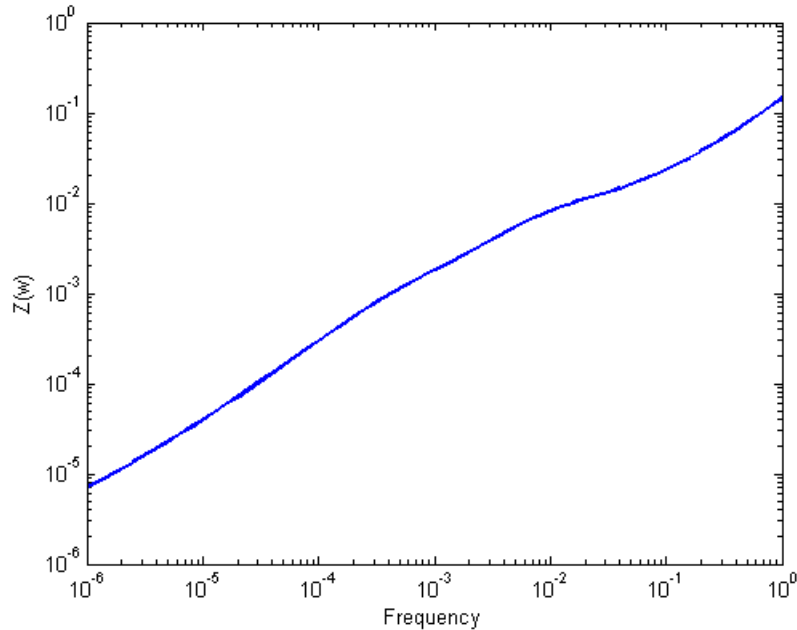
\*denotes convolution in the time domain,

$z(t)$  is the impulse response for the earth surface impedance calculated from the laterally uniform or 1D earth model,

$B_E(t)$ ,  $B_N(t)$  are the scaled Eastward and Northward geomagnetic field waveforms, and

$|E_E(t)$ ,  $E_N(t)|$  are the magnitudes of the calculated Eastward and Northward goelectric field  $E_E(t)$  and  $E_N(t)$ .

As noted previously, the response of the earth to  $B(t)$  (and  $dB/dt$ ) is frequency dependent. Figure II-2 shows the magnitude of  $Z(\omega)$  for the reference earth model.



**Figure II-2: Magnitude of the Earth Surface Impedance for the Reference Earth Model**

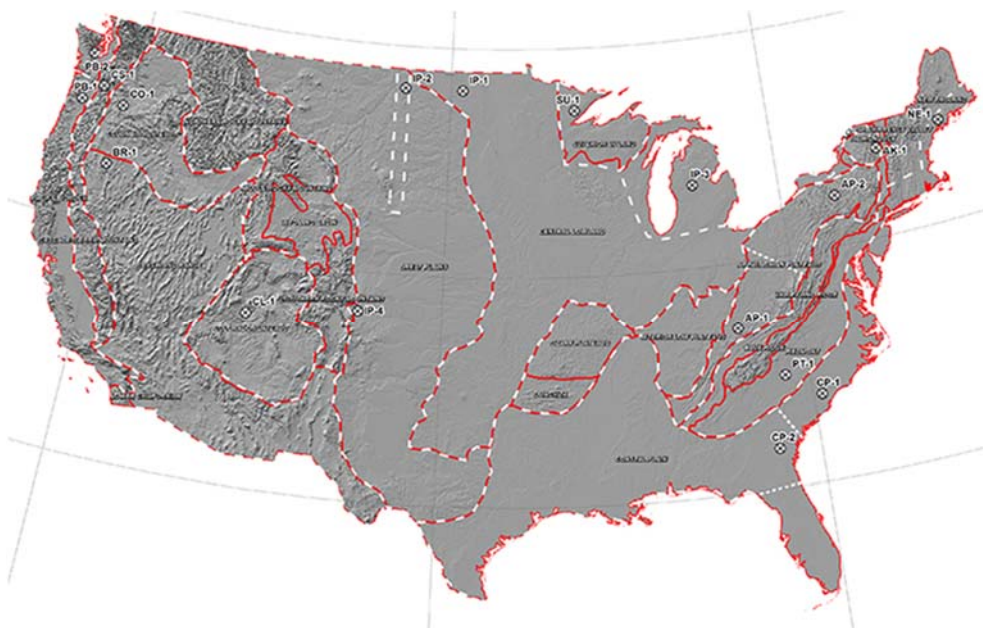
If a utility does not have the capability of calculating the waveform or time series for the geoelectric field, an earth conductivity scaling factor  $\beta_s$  can be obtained from Table II-2. Using  $\alpha$  and  $\beta$ , the peak geoelectric field  $E_{peak}$  for a specific service territory shown in Figure II-3 can be obtained using (II.3).

$$E_{peak} = 12 \times \alpha \times \beta_s (V/km) \quad (II.3)$$

It should be noted that (II.3) is an approximation based on the following assumptions:

- The earth models used to calculate Table II-2 for the United States are from published information available on the USGS website. These scaling factors are slightly lower than the ones in the benchmark because the supplemental benchmark waveform has a higher frequency content at the time of the local enhancement.
- The models used to calculate Table II-2 for Canada were obtained from NRCAN and reflect the average structure for large regions. When models are developed for sub-regions, there will be variance (to a greater or lesser degree) from the average model. For instance, detailed models for Ontario have been developed by NRCAN and consist of seven major sub-regions.
- The conductivity scaling factor  $\beta_s$  is calculated as the quotient of the local geoelectric field peak amplitude in a physiographic region with respect to the reference peak amplitude value of 12 V/km. Both geoelectric field peak amplitudes are calculated using the supplemental geomagnetic field time series. If a different geomagnetic field time series were used, the calculated scaling factors ( $\beta$ ) would be different than the values in Table II-2 because the frequency content of storm maxima is, in principle, different for every storm. If a utility has technically-sound earth models for its service territory and sub-regions thereof, then the use of such earth models is preferable to estimate  $E_{peak}$ .
- When a ground conductivity model is not available the planning entity should use the largest  $\beta_s$  factor of adjacent physiographic regions or a technically-justified value.

### Physiographic Regions of the Continental United States



### Physiographic Regions of Canada



Figure II-3: Physiographic Regions of North America

<b>Table II-2 Supplemental Geoelectric Field Scaling Factors</b>	
<b>Earth model</b>	<b>Scaling Factor (<math>\beta</math>)</b>
AK1A	0.51
AK1B	0.51
AP1	0.30
AP2	0.78
BR1	0.22
CL1	0.73
CO1	0.25
CP1	0.77
CP2	0.86
FL1	0.73
CS1	0.37
IP1	0.90
IP2	0.25
IP3	0.90
IP4	0.35
NE1	0.77
PB1	0.55
PB2	0.39
PT1	1.19
SL1	0.49
SU1	0.90
BOU	0.24
FBK	0.56
PRU	0.22
BC	0.62
PRAIRIES	0.88
SHIELD	1.0
ATLANTIC	0.76

## References

---

- [1] *High-Impact, Low-Frequency Event Risk to the North American Bulk Power System*, A Jointly-Commissioned Summary Report of the North American Reliability Corporation and the U.S. Department of Energy's November 2009 Workshop.
- [2] Application Guide: Computing Geomagnetically-Induced Current in the Bulk-Power System, NERC. December 2013. [http://www.nerc.com/comm/PC/Geomagnetic%20Disturbance%20Task%20Force%20GMDTF%202013/GIC%20Application%20Guide%202013\\_approved.pdf](http://www.nerc.com/comm/PC/Geomagnetic%20Disturbance%20Task%20Force%20GMDTF%202013/GIC%20Application%20Guide%202013_approved.pdf)
- [3] Boteler, D. H.; Pirjola R. J.; Liu, L.; and Zheng, K.; "Geoelectric Fields Due to Small-Scale and Large-Scale Source Currents." *IEEE Transactions on Power Delivery*, Vol. 28, No. 1, January 2013, pp. 442-449.
- [4] Boteler, D. H. "Geomagnetically Induced Currents: Present Knowledge and Future Research." *IEEE Transactions on Power Delivery*, Vol. 9, No. 1, January 1994, pp. 50-58.
- [5] Boteler, D. H. "Modeling Geomagnetically Induced Currents Produced by Realistic and Uniform Electric Fields." *IEEE Transactions on Power Delivery*, Vol. 13, No. 4, January 1998, pp. 1303-1308.
- [6] Gilbert, J. L.; Radasky, W. A.; and Savage, E. B. "A Technique for Calculating the Currents Induced by Geomagnetic Storms on Large High Voltage Power Grids." Electromagnetic Compatibility (EMC). 2012 IEEE International Symposium on.
- [7] *How to Calculate Electric Fields to Determine Geomagnetically-Induced Currents*. EPRI, Palo Alto, CA: 2013. 3002002149.
- [8] Pirjola, R.; Pulkkinen, A.; and Viljanen, V. Statistics of extreme geomagnetically induced current events, *Space Weather*, 6, S07001, doi:10.1029/2008SW000388, 2008.
- [9] Boteler, D. H. Assessment of geomagnetic hazard to power systems in Canada, *Nat. Hazards*, 23, 101–120. 2001.
- [10] Finnish Meteorological Institute's IMAGE magnetometer chain data available at: <http://image.gsfc.nasa.gov/>
- [11] Boteler, D. H. and Pirjola, R. J. The complex-image method for calculating the magnetic and electric fields produced at the surface of the Earth by the auroral electrojet. *Geophys. J. Int.*, 132(1), 31–40. 1998.
- [12] Coles, S. *An Introduction to Statistical Modelling of Extreme Values*. Springer. 2001.
- [13] Clarke, E.; McKay, A.; Pulkkinen, A.; and Thomson, A. April 2000 geomagnetic storm: ionospheric drivers of large geomagnetically induced currents. *Annales Geophysicae*, 21, 709-717. 2003.
- [14] Lindahl, S.; Pirjola, R. J.; Pulkkinen, A.; and Viljanen, A. Geomagnetic storm of 29–31 October 2003: Geomagnetically induced currents and their relation to problems in the Swedish high-voltage power transmission system. *Space Weather*, 3, S08C03, doi:10.1029/2004SW000123. 2005.
- [15] Beggan, C.; Bernabeu, E.; Eichner, J.; Pulkkinen, A.; and Thomson, A., Generation of 100-year geomagnetically induced current scenarios, *Space Weather*, Vol. 10, S04003, doi:10.1029/2011SW000750. 2012.

- [16] Crowley, G.; Ngwira, C.; Pulkkinen, A.; and Wilder, F. Extended study of extreme geoelectric field event scenarios for geomagnetically induced current applications. *Space Weather*, Vol. 11, 121–131, doi:10.1002/swe.20021. 2013.
- [17] Dawson, E.; Reay, S.; and Thomson, A. Quantifying extreme behavior in geomagnetic activity. *Space Weather*, 9, S10001, doi:10.1029/2011SW000696. 2011.

**NERC**

NORTH AMERICAN ELECTRIC  
RELIABILITY CORPORATION

# Supplemental Geomagnetic Disturbance Event Description

Project 2013-03 GMD Mitigation

~~June~~October 2017

**RELIABILITY | ACCOUNTABILITY**



3353 Peachtree Road NE  
Suite 600, North Tower  
Atlanta, GA 30326  
404-446-2560 | [www.nerc.com](http://www.nerc.com)

# Table of Contents

---

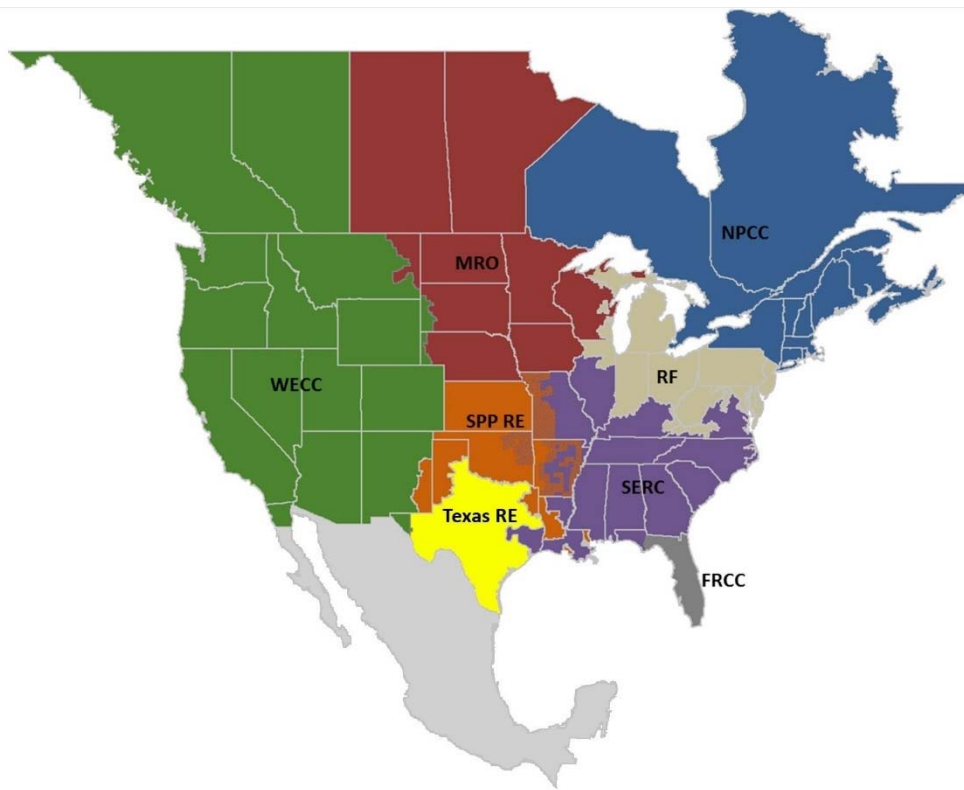
Preface.....	iii
Introduction.....	iv
Background .....	iv
General Characteristics.....	iv
Supplemental GMD Event Description.....	1
Supplemental GMD Event Geoelectric Field Amplitude.....	1
Supplemental Geomagnetic Field Waveform.....	1
Appendix I – Technical Considerations.....	4
Statistical Considerations.....	4
Extreme Value Analysis .....	4
Spatial Considerations .....	8
Local Enhancement Waveform.....	14
Transformer Thermal Assessment.....	16
Appendix II – Scaling the Supplemental GMD Event.....	17
Scaling the Geomagnetic Field.....	17
Scaling the Geoelectric Field.....	18
References .....	22



# Preface

The North American Electric Reliability Corporation (NERC) is a not-for-profit international regulatory authority whose mission is to assure the reliability and security of the bulk power system (BPS) in North America. NERC develops and enforces Reliability Standards; annually assesses seasonal and long-term reliability; monitors the BPS through system awareness; and educates, trains, and certifies industry personnel. NERC’s area of responsibility spans the continental United States, Canada, and the northern portion of Baja California, Mexico. NERC is the Electric Reliability Organization (ERO) for North America, subject to oversight by the Federal Energy Regulatory Commission (FERC) and governmental authorities in Canada. NERC’s jurisdiction includes users, owners, and operators of the BPS, which serves more than 334 million people.

The North American BPS is divided into eight Regional Entity (RE) boundaries as shown in the map and corresponding table below.



*The North American BPS is divided into eight RE boundaries. The highlighted areas denote overlap as some load-serving entities participate in one Region while associated transmission owners/operators participate in another.*

<b>FRCC</b>	Florida Reliability Coordinating Council
<b>MRO</b>	Midwest Reliability Organization
<b>NPCC</b>	Northeast Power Coordinating Council
<b>RF</b>	ReliabilityFirst
<b>SERC</b>	SERC Reliability Corporation
<b>SPP RE</b>	Southwest Power Pool Regional Entity
<b>Texas RE</b>	Texas Reliability Entity
<b>WECC</b>	Western Electricity Coordinating Council

# Introduction

---

## Background

Proposed TPL-007-2 includes requirements for entities to perform two types of [geomagnetic disturbance \(GMD\)](#) Vulnerability Assessments to evaluate the potential impacts of GMD events on the Bulk Electric System (BES):

- The benchmark GMD Vulnerability Assessment is based on the benchmark GMD event associated with TPL-007-1, which was approved by the [Federal Energy Regulatory Commission \(FERC\)](#) in Order No. 830 in September 2016. The benchmark GMD event is derived from spatially-averaged geoelectric field values to address potential wide-area effects that could be caused by a severe 1-in-100 year GMD event.<sup>1</sup>
- The supplemental GMD Vulnerability Assessment, based on the supplemental GMD event described in this white paper, is used by entities to evaluate localized enhancements of geomagnetic field during a severe GMD event that "could potentially affect the reliable operation of the Bulk-Power System."<sup>2</sup> Localized enhancements of geomagnetic field can result in geoelectric field values above the spatially-averaged benchmark in a local area.

The purpose of the supplemental [geomagnetic disturbance \(GMD\)](#) event description is to provide a defined event for assessing system performance for a GMD event which includes a local enhancement of the geomagnetic field. In addition to varying with time, geomagnetic fields can be spatially non-uniform with higher and lower strengths across a region. This spatial non-uniformity has been observed in a number of GMD events, so localized enhancement of field strength above the average value is considered. The supplemental GMD event defines the geomagnetic and geoelectric field values used to compute geomagnetically-induced current (GIC) flows for a supplemental GMD Vulnerability Assessment.

## General Characteristics

The supplemental GMD event described herein takes into consideration observed characteristics of a local geomagnetic field enhancement, recognizing that the science and understanding of these events is evolving. Based on observations and initial assessments, the characteristics of local enhancements include:

- Geographic area – The extent of local enhancements is on the order of 100km in North-South (latitude) direction but longer in East-West (longitude) direction. Further description of the geographic area is provided later in the white paper.
- Amplitude – The amplitude of the resulting geoelectric field is significantly higher than the geoelectric field that is calculated in the spatially-averaged Benchmark GMD event.
- Duration – The local enhancement in the geomagnetic field occurs over a time period of [2-5two to five](#) minutes.
- Geoelectric field waveform – The supplemental GMD event waveform is the benchmark GMD event waveform with the addition of a local enhancement. The added local enhancement has amplitude and duration characteristics described above. The geoelectric field waveform has a strong influence on the hot spot heating of transformer windings and structural parts since thermal time constants of the transformer and time to peak of storm maxima are both on the order of minutes. The frequency content of the rate of change of the magnetic field (dB/dt) is a function of the waveform, which in turn has a direct

---

<sup>1</sup> See *Benchmark Geomagnetic Disturbance Event Description* white paper, May 12, 2016. Filed by NERC in RM 15-11 on June 28, 2016.

<sup>2</sup> See [FERC](#) Order No. 830, P. 47. [On September 22, 2016 in Order 830](#), FERC directed NERC to develop modifications to the benchmark GMD event, included in TPL-007-1, such that assessments would not be based solely on spatially averaged data.

effect on the geoelectric field since the earth response to dB/dt is frequency-dependent. As with the benchmark GMD event, the supplemental GMD event waveform is based on magnetic field data recorded by the Natural Resources Canada (NRCan) Ottawa (OTT) geomagnetic observatory during the March 13-14, 1989 event. This GMD event data was selected because analysis of recorded events indicates that the OTT observatory data for this period provides conservative results when performing thermal assessments of power transformers.<sup>3</sup>

---

<sup>3</sup> See *Benchmark Geomagnetic Disturbance Event Description* white paper, page 5 and Appendix I.

# Supplemental GMD Event Description

Severe ~~geomagnetic disturbance~~**GMD** events are high-impact, low-frequency (HILF) events [1]; thus, GMD events used in system planning should consider the probability that the event will occur, as well as the impact or consequences of such an event. The supplemental GMD event is composed of the following elements: 1) a reference peak geoelectric field amplitude (V/km) derived from statistical analysis of historical magnetometer data; 2) scaling factors to account for local geomagnetic latitude; 3) scaling factors to account for local earth conductivity; and 4) a reference geomagnetic field time series or waveform to facilitate time-domain analysis of GMD impact on equipment.

## Supplemental GMD Event Geoelectric Field Amplitude

The supplemental GMD event field amplitude was determined through statistical analysis using the plane wave method [2]-[9] of geomagnetic field measurements from geomagnetic observatories in northern Europe [10] and the **North American (i.e., Québec)** ~~(Quebec)~~ earth model shown in Table 1 [11], supplemented by data from Greenland, Denmark and **United States (i.e., Alaska-)**. For details of the statistical considerations, see Appendix I. The ~~Quebec~~**Québec** earth model is generally resistive and the geological structure is relatively well understood.

Thickness (km)	Resistivity ( $\Omega$ -m)
15	20,000
10	200
125	1,000
200	100
$\infty$	3

The statistical analysis (see Appendix I) resulted in conservative peak geoelectric field amplitude of approximately 12 V/km. For steady-state GIC and load flow analysis, the direction of the geoelectric field is assumed to be variable meaning that it can be in any direction (Eastward, Northward, or a vectorial combination thereof).

The regional geoelectric field peak amplitude,  $E_{peak}$ , to be used in calculating GIC in the GIC system model can be obtained from the reference value of 12 V/km using the following relationship

$$E_{peak} = \underline{\underline{E_{peak} = 12 \times \alpha \times \beta_s (V/km)}} \underline{\underline{(V/km)}} \quad (1)$$

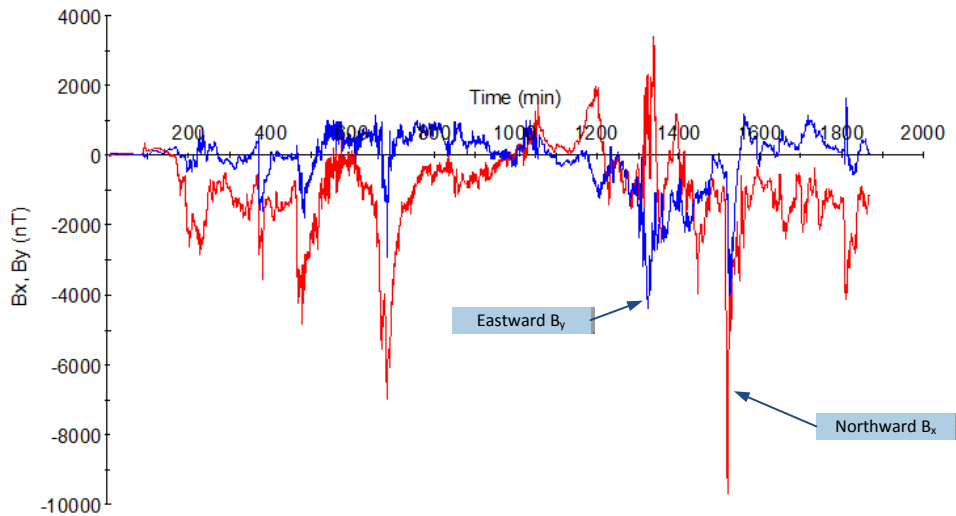
where  $\alpha$  is the scaling factor to account for local geomagnetic latitude, and  $\beta_s$  is a scaling factor for the supplemental GMD event to account for the local earth conductivity structure (see Appendix II).

## Supplemental Geomagnetic Field Waveform

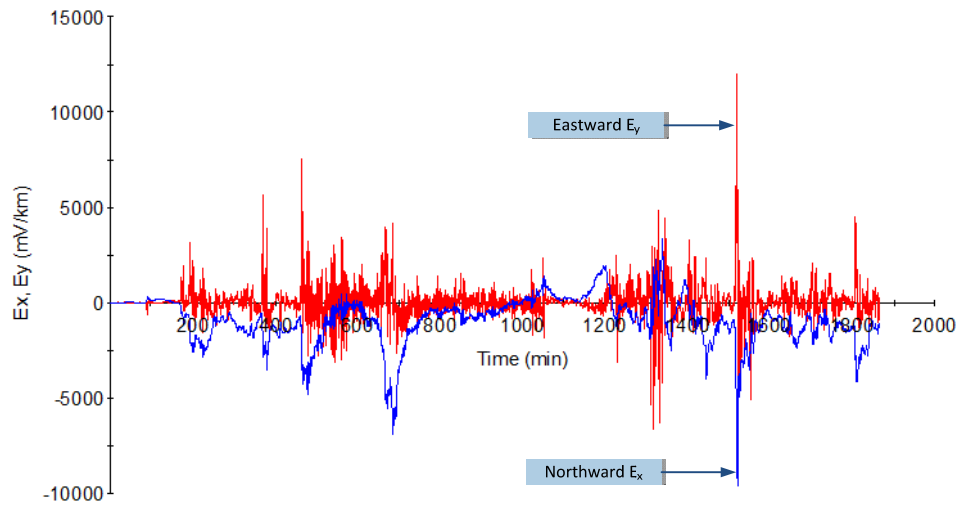
The supplemental geomagnetic field waveform is the benchmark geomagnetic field waveform with the addition of a local enhancement. Both the benchmark and supplemental geomagnetic field waveforms are used to calculate the GIC time series,  $GIC(t)$ , required for transformer thermal impact assessments. The supplemental waveform includes a local enhancement, inserted at UT 1:18 March 14, **1989** in Figure 1 below. This time corresponds to the largest calculated geoelectric fields during the benchmark GMD event. The amplitude of the local enhancement is based on a statistical analysis of a number of GMD events, discussed in Appendix I. The

duration of the enhancement is based on the characteristics of observed localized enhancements as discussed in Appendix I.

The geomagnetic latitude of the Ottawa geomagnetic observatory is 55°; therefore, the amplitude of the geomagnetic field measurement data with a local enhancement was scaled up to the 60° reference geomagnetic latitude (see Figure 1) such that the resulting peak geoelectric field amplitude computed using the reference earth model was 12 V/km (see Figure 2). Sampling rate for the geomagnetic field waveform is 10 seconds.



**Figure 1: Supplemental Geomagnetic Field Waveform**  
 Red  $B_x$  (Northward), Blue  $B_y$  (Eastward), Referenced to pre-event quiet conditions



**Figure 2: Supplemental Geoelectric Field Waveform**  
Red  $E_y$  (Eastward) and Blue  $E_x$  (Northward)

## Appendix I – Technical Considerations

---

The following sections describe the technical justification of the assumptions that were made in the development of the supplemental GMD event.

### Statistical Considerations

The peak geoelectric field amplitude of the supplemental GMD event was determined through statistical analysis of modern 10-second geomagnetic field data and corresponding calculated geoelectric field amplitudes. The objective of the analysis was to estimate the geoelectric field amplitude that is associated with a 1 in 100 year frequency of occurrence. The same data set and similar statistical techniques were used in determining the peak geoelectric field amplitude of the benchmark GMD event, including extreme value analysis discussed in the following section.<sup>4</sup> The fundamental difference in the supplemental GMD event amplitude is that it is based on observations taken at each individual station (i.e., localized measurements), in contrast with the spatially averaged geoelectric fields used in the *Benchmark Geomagnetic Disturbance Event Description* white paper.<sup>5</sup>

### Extreme Value Analysis

The objective of extreme value analysis is to describe the behavior of a stochastic process at extreme deviations from the median. In general, the intent is to quantify the probability of an event more extreme than any previously observed. In particular, we are concerned with estimating the 95% confidence interval of the maximum geoelectric field amplitude to be expected within a 100-year return period.<sup>6</sup>

The data set consists of 23 years of daily maximum geoelectric field amplitudes derived from individual stations<sup>7</sup> in the IMAGE magnetometer chain, using the [QuebecQuébec](#) earth model as a reference. Figure I-1 shows a scatter plot of geoelectric field amplitudes that exceed 2 V/km across the IMAGE stations. The plot indicates that there is seasonality in extreme observations associated with the 11-year solar cycle.

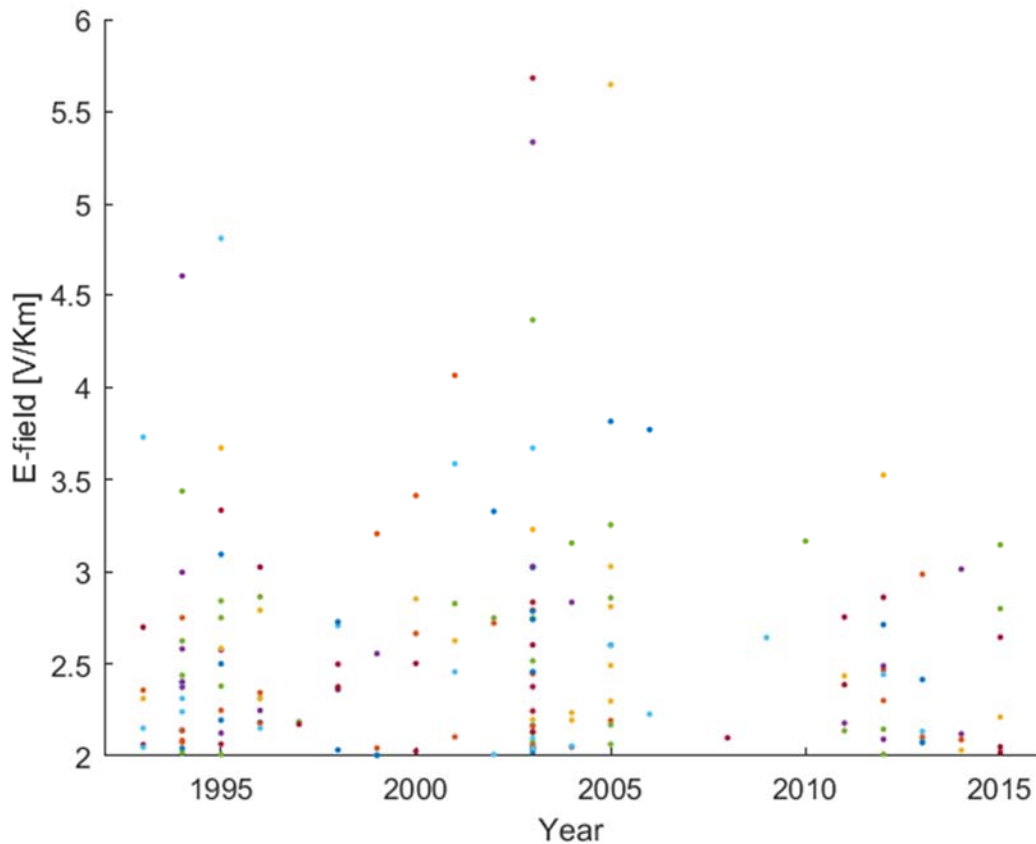
---

<sup>4</sup> See *Benchmark Geomagnetic Disturbance Event Description* white paper, Appendix I, pages 8-13.

<sup>5</sup> Averaging the geoelectric field values of stations in geographic groups is referred to as spatial averaging in the *Benchmark Geomagnetic Disturbance Event Description*. Spatial averaging was used to characterize GMD events over a geographic area relevant to the interconnected transmission system for purposes of assessing area effects such as voltage collapse and widespread equipment risk. See *Benchmark Geomagnetic Disturbance Event Description* white paper, Appendix I, pages 9-10.

<sup>6</sup> A 95 percent confidence interval means that, if repeated samples were obtained, the return level would lie within the confidence interval for 95 percent of the samples.

<sup>7</sup> US – <https://geomag.usgs.gov/>; Canada – <http://geomag.nrcan.gc.ca/lab/default-en.php>.



**Figure I-1: Scatter Plot of Geoelectric Fields that Exceed a 2 V/km Threshold**

Data source [11]: IMAGE magnetometer chain from 1993-2015.

Several statistical methods can be used to conduct extreme value analysis. The most commonly applied include: Generalized Extreme Value (GEV), Point Over Threshold (POT), R-Largest, and Point Process (PP). In general, all methods assume independent and identically distributed (iid) data [12].

Table I-1 shows a summary of the estimated parameters and return levels obtained from different statistical methods. The parameters were estimated using the Maximum Likelihood Estimator (MLE). Since the distribution parameters do not have an intuitive interpretation, the expected geoelectric field amplitude for a 100-year return period is also included in Table I-1. The 95% confidence interval of the 100-year return level was calculated using the delta method and the profile likelihood. The delta method relies on the Gaussian approximation to the distribution of the MLE; this approximation can be poor for long return periods. In general, the profile likelihood provides a better description of the return level.



Table I-1: Extreme Value Analysis					
Statistical Model	Estimated Parameters	Hypothesis Testing	100 Year Return Level		
			Mean [V/km]	95% CI Delta [V/km]	95% CI P-Likelihood [V/km]
(1) GEV	$\mu=2.976$ (0.193)  $\sigma=0.829$ (0.1357)  $\xi=-0.0655$ (0.1446)	$H_0: \xi=0$ $p = 0.66$	6.9	[4.3, 8.2]	[5.2, 11.4]
(2) GEV, reparametrization $\mu = \beta_0 + \beta_1 \times \sin\left(\frac{t}{T} + \phi\right)$	$\beta_0 = 2.964$ (0.151)  $\beta_1=0.582$ (0.155)  $\sigma=0.627$ (0.114)  $\xi=0.09$ (0.183)	$H_0: \beta_1=0$ $p = 0.00$  $H_0: \xi=0$ $p = 0.6$	7.1	[4, 10.2]	[5.5, 18]
(3) POT, threshold=2 V/km 3 day decluster. 143 observations > 2V/km.	$\sigma=0.592$ (0.074)  $\xi=0.077$ (0.093)		6.9	[4.5, 9.4]	[5.4, 11.9]
(4) POT, threshold=2V/km reparametrization, $\sigma = \beta_0 + \beta_1 \times \sin\left(\frac{t}{T} + \phi\right)$	$\beta_0=0.58$ (0.073)  $\beta_1=0.107$ (0.082)  $\xi=0.037$ (0.097)	$H_0: \beta_1=0$ $p = 0.2$	7	[4.6, 9.3]	[5.5, 11.7]

Statistical model (1) in Table I-1 is the traditional GEV estimation using blocks of one year maxima; i.e., only 23 data points are used in the estimation. The mean expected amplitude of the geoelectric field for a 100-year return level is approximately 7 V/km. Since GEV works with blocks of maxima, it is typically regarded as a wasteful approach.

As discussed previously, GEV assumes that the data is iid. Based on the scatter plot shown in Figure I-1, the iid statistical assumption is not warranted by the data. Statistical model (2) in Table I-1 is a reparametrization of the GEV distribution contemplating the 11-year seasonality in the mean,

$$\mu = \beta_0 + \beta_1 \times \sin\left(\frac{t}{T} + \phi\right)$$

where  $\beta_0$  represents the offset in the mean,  $\beta_1$  describes the 11-year seasonality,  $T$  is the period (11 years), and  $\phi$  is a constant phase shift.

A likelihood ratio test is used to test the hypothesis that  $\beta_1$  is zero. The null hypothesis,  $H_0: \beta_1=0$ , is rejected with a p-value of 0.0032; as expected, the 11-year seasonality has explanatory power. The blocks of maxima during the solar minimum are better represented in the reparametrized GEV. The mean return level is still 7 V/km, but the confidence interval is wider, [5.5, 18] V/km for the profile likelihood (calculated at solar maximum).

Statistical model (3) in Table I-1 is the traditional POT estimation using a threshold  $u$  of 2 V/km; the data was declustered using a 1-day run. The data set consists of normalized excesses over a threshold, and therefore, the sample size for POT is increased if more than one extreme observation per year is available (in the GEV approach, only the maximum observation over the year was taken; in the POT method, a single year can have multiple observations over the threshold). The selection of the threshold  $u$  is a compromise between bias and variance. The asymptotic basis of the model relies on a high threshold; too low a threshold will likely lead to bias. On the other hand, too high a threshold will reduce the sample size and result in high variance. A threshold of 2V/km was determined to be a good choice, giving rise to 143 observations above the threshold.

The mean return level for statistical model (3),  $\sim 7$  V/km, is consistent with the GEV estimates. However, due to the larger sample size the POT method is more efficient rendering a confidence interval of [5.4, 11.9] V/km for the profile likelihood method.

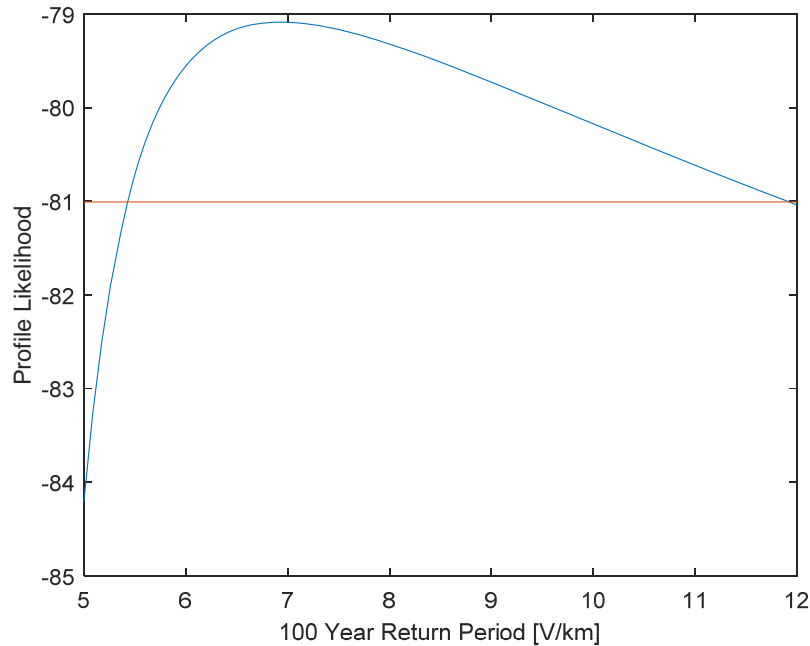
In an attempt to cope with potential heteroskedasticity in the data, a reparametrization of POT is proposed in statistical model (4) in Table I-1,

$$\sigma = \alpha_0 + \alpha_1 \times \sin\left(\frac{t}{T} + \phi\right)$$

where  $\alpha_0$  represents the offset in the standard deviation,  $\alpha_1$  describes the 11-year seasonality,  $T$  is the period (365.25 · 11), and  $\phi$  is a constant phase shift.

The parameter  $\alpha_1$  is not statistically significant; the null hypothesis,  $H_0: \alpha_1=0$ , is not rejected with a p-value of 0.2. The proposed reparametrization does not have explanatory power, and consequently, the mean return level 7 V/km and confidence intervals remain virtually unchanged [5.5, 11.7]. As a final remark, it is emphasized that the confidence interval obtained using the profile likelihood is preferred over the delta method.

Figure I-2 shows the profile likelihood of the 100-year return level of statistical model (3). Note that the profile likelihood is highly asymmetric with a positive skew, rendering a larger upper limit for the confidence interval. Recall that the delta method assumes a normal distribution for the MLEs, and therefore, the confidence interval is symmetric around the mean.



**Figure I-2: Profile Likelihood for 100-year Return Level for Statistical Model (3)**

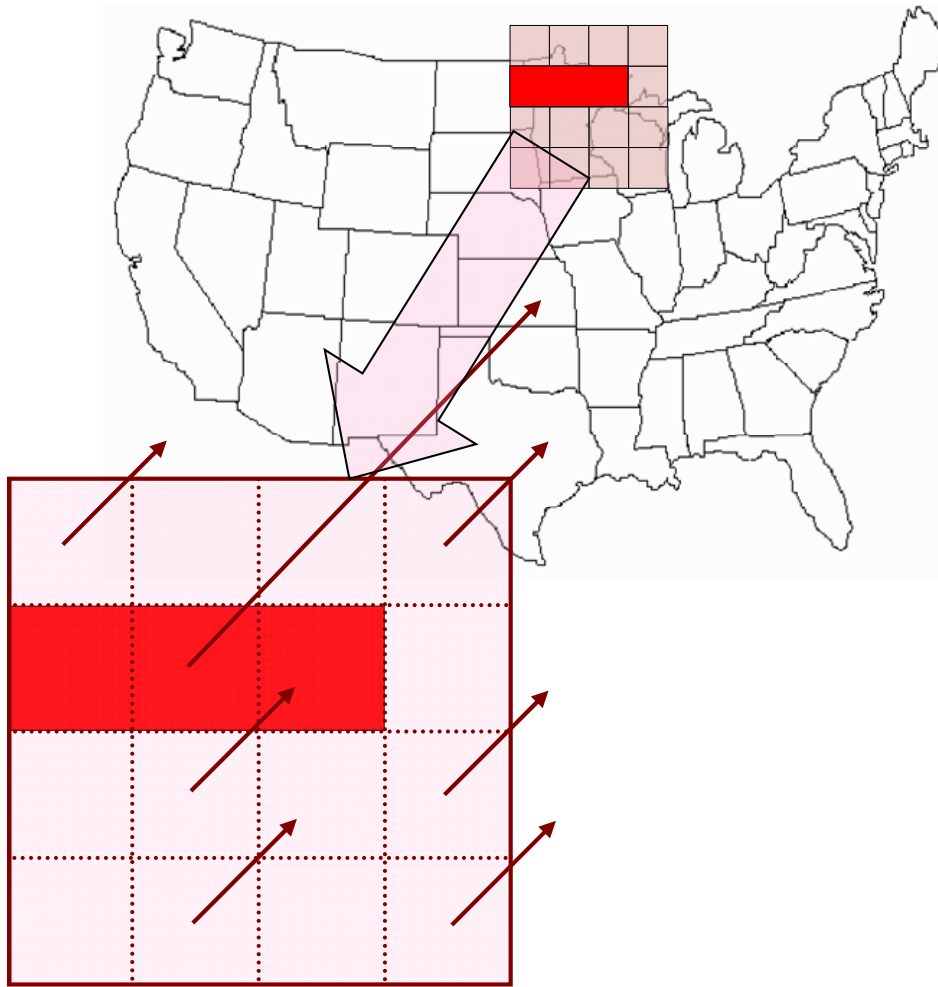
To conclude, the traditional GEV (1) is misspecified; the statistical assumptions (*i.e.*, iid) are not warranted by the data. The model was reparametrized to cope with seasonality in the data. Statistical models (3) and (4) better utilize the available extreme measurements and they are therefore preferred over statistical model (2). A geoelectric field amplitude of 12 V/km is selected for the supplemental GMD event to represent the upper limit of the 95 percent confidence interval for a 100-year return interval.

## Spatial Considerations

The spatial structure of high-latitude geomagnetic fields can be very complex during strong geomagnetic storm events [13]-[14]. One reflection of this spatial complexity is localized geomagnetic field enhancements (local enhancements) that result in high amplitude geoelectric fields in regions of a few hundred kilometers. Figure I-3 illustrates this spatial complexity of the storm-time geoelectric fields.<sup>8</sup> In areas indicated by the bright red location, the geoelectric field can be substantially larger than at neighboring locations. These enhancements are primarily the result of external (geomagnetic field) conditions, and not local geological factors such as coastal effects.<sup>9</sup>

<sup>8</sup> Figure I-3 is for illustration purposes only, and is not meant to suggest that a particular area is more likely to experience a localized enhanced geoelectric field. The depiction is not to scale.

<sup>9</sup> Localized externally-driven geomagnetic phenomena should not be confused with localized geoelectric field enhancements due to complex electromagnetic response of the ground to external excitation. Complex 3D geological conditions such as those at coastal regions can lead to localized geoelectric field enhancements but those are not considered here.



**Figure I-3: Illustration of the Spatial Scale between Localized Enhancements and Larger Spatial Scale Amplitudes of Goelectric Field during a Strong Geomagnetic Storm**

In this figure, the red rectangle illustrates a spatially localized field enhancement.

The supplemental GMD event is designed to address local effects caused by a severe GMD event, such as increased var absorption and voltage depressions.

A number of GMD events were analyzed to identify the basic characteristics of local enhancements. Three (3) solar storms studied and described below are:

- March 13, 1989
- —●— October 29-30, 2003
- —●— March 17, 2015

Four localized events within those storms were identified and analyzed. Geomagnetic field recordings were collected for these storms and the geoelectric field was computed using the 1D plane wave method and the reference ~~Quebec~~ Québec ground model. In each case, a local enhancement was correlated, generally oriented parallel to the westward ionospheric electrojet associated with ongoing larger scale geomagnetic activity. (See Figures I-4 ~~—~~ I-7 below).

Goelectric field distribution 0089-03-13T21:44:00 UT. Max. IEI: 5.90 V/km.

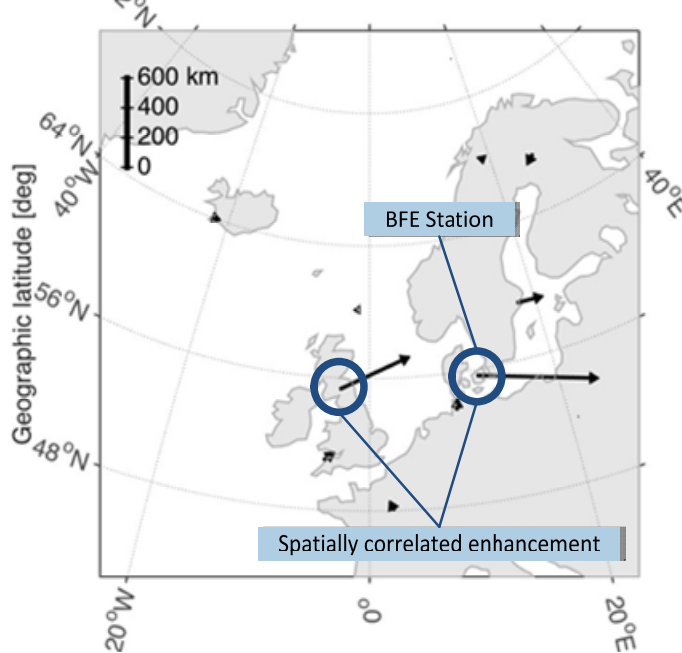


Figure I-4: March 13, 1989, at 21:44 UT, Brorfelde (BFE), Denmark

Goelectric field distribution 2003-10-29T06:47:20 UT. Max. IEI: 9.31 V/km.

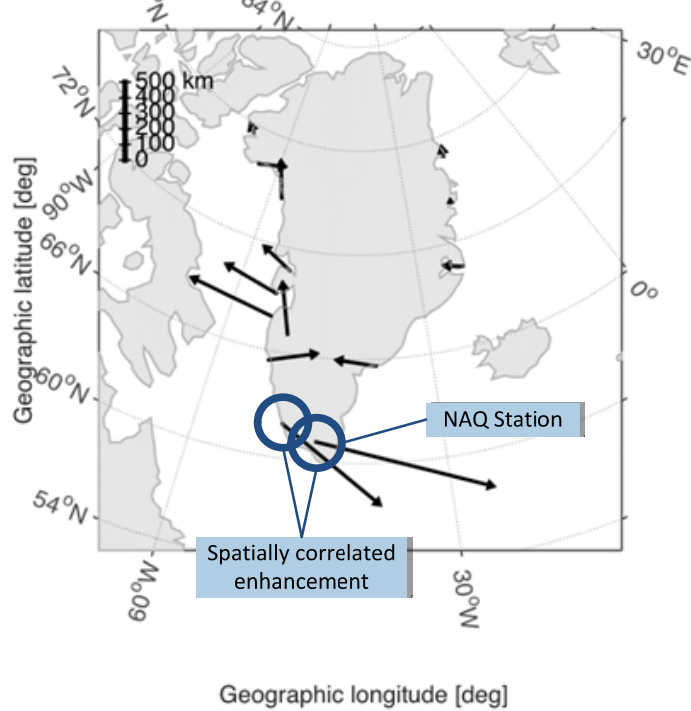


Figure I-5: October 29, 2003, at 06:47 UT, Narsarsuaq (NAQ), Greenland

Goelectric field distribution 2003-10-30T16:49:30 UT. Max. IEI: 5.68 V/km.

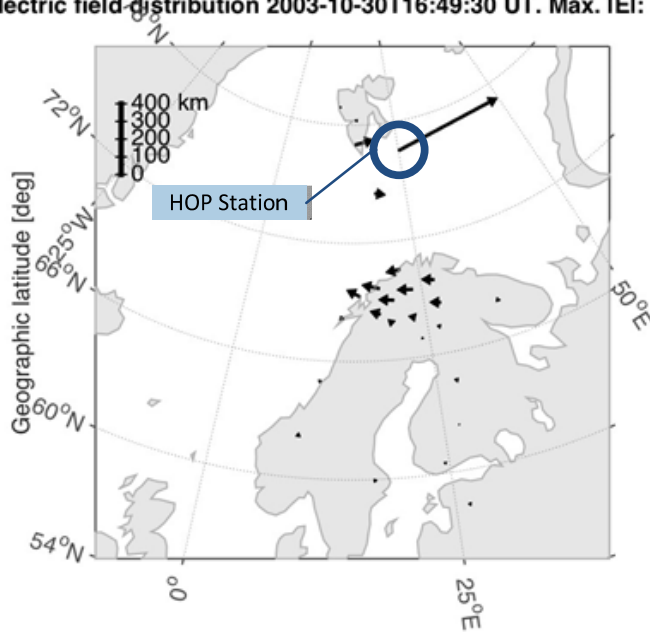


Figure I-6: October 30, 2003, at 16:49UT, Hopen Island (HOP), Svalbard, Norway

Goelectric field distribution 2015-03-17T13:33:00 UT. Max. IEI: 3.46 V/km.

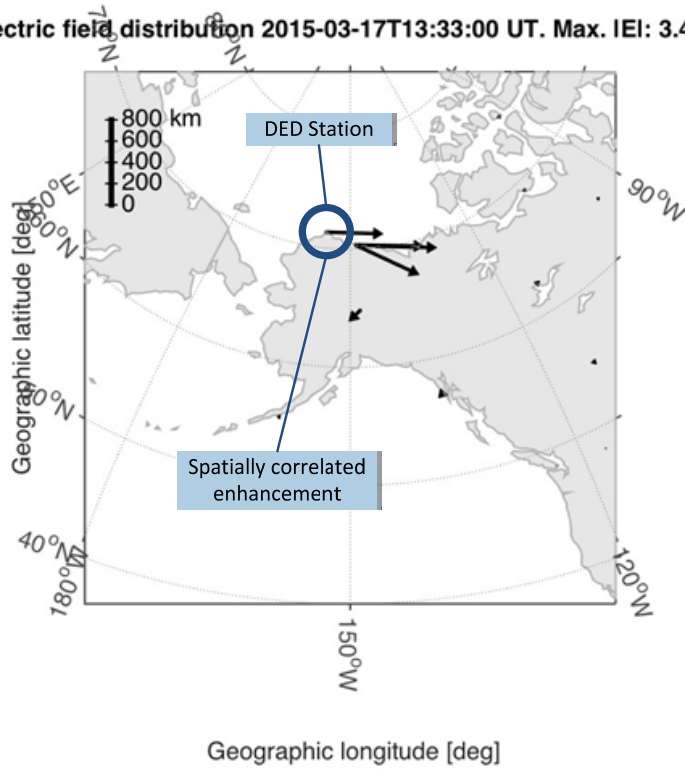


Figure I-7: March 17, 2015, at 13:33 UT, Deadhorse, Alaska, USA

All of the above events were analyzed by reviewing the time series magnetic field data and transforming it to an electric field and focusing on the time period of the spatially correlated local enhancement. There were apparent similarities in the character of the local enhancements. The local enhancements occurred during peak periods of geomagnetic activity and were distinguished by relatively brief excursions of rapid magnetic field variation. With respect to time duration, the local enhancements generally occurred over a period of 2-5 minutes. (See Figures I-8 – I-11)

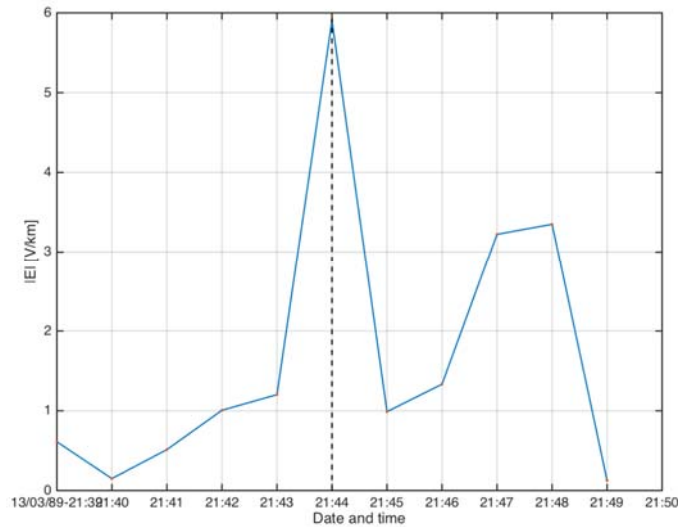


Figure I-8: Geoelectric field March 13, 1989, at 21:44 UT, Brorfelde (BFE), Denmark

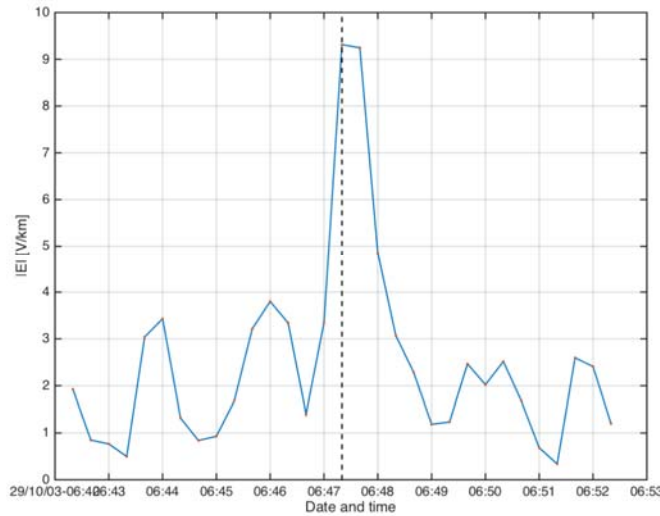
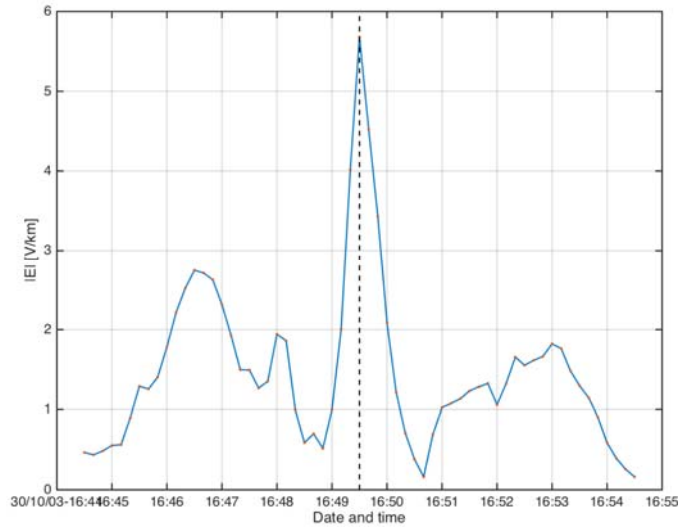
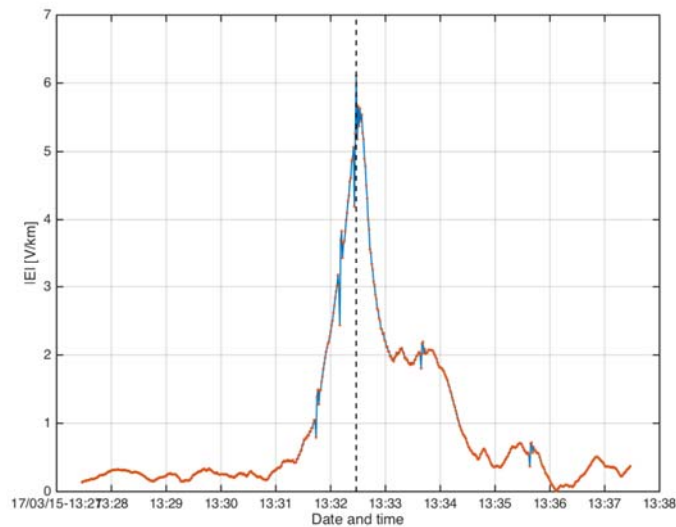


Figure I-9: Geoelectric field October 29, 2003, at 06:47 UT, Narsarsuaq (NAQ), Greenland



**Figure I-10: Geoelectric field October 30, 2003, at 16:49 UT, Hopen Island (HOP), Norway**



**Figure I-11 – Geoelectric field March 17, 2015, at 13:33 UT, Deadhorse, Alaska, USA**

Based on the above analysis and the previous work associated with the benchmark GMD event, it is reasonable to incorporate a second (or supplemental) assessment into TPL-007-2 to account for the potential impact of a local enhancement in both the network analysis and the transformer thermal assessment(s).

With respect to geographic area of the localized enhancement, the historical geomagnetic field data analyzed so far provides some insight. Analysis suggests that the enhancements will occur in a relatively narrow band of geomagnetic latitude (on the order of 100 km) and wider longitudinal width (on the order of 500 km) as a consequence of the westward-oriented structure of the source in the ionosphere.



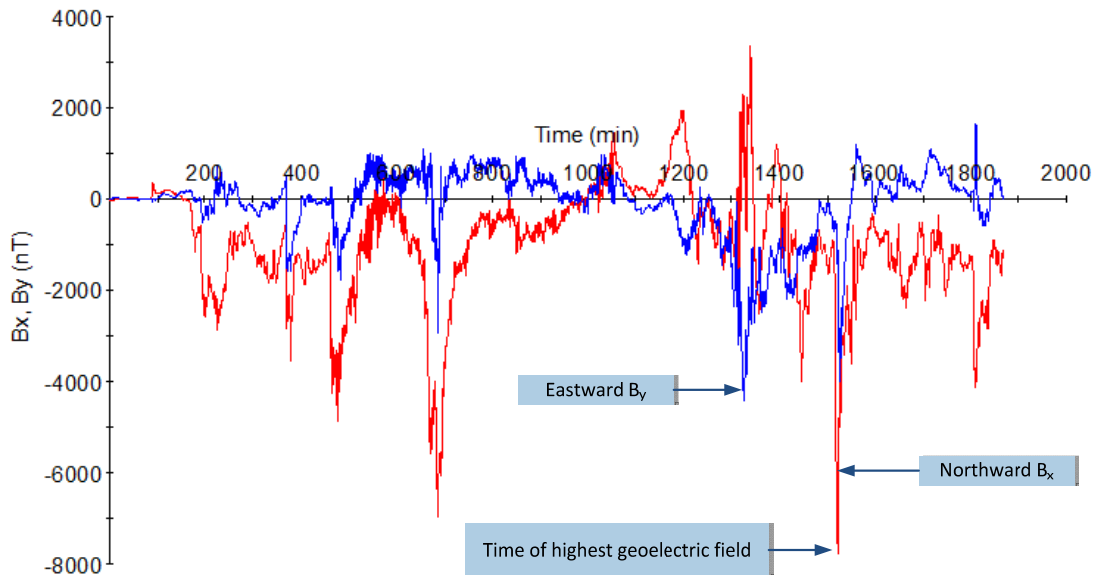
Proposed TPL-007-2 provides flexibility for planners to determine how to apply the supplemental GMD event to the planning area. Acceptable approaches include, but are not limited to:

- ~~Apply~~**Applying** the peak geoelectric field for the supplemental GMD event (12 V/km scaled to the planning area) over the entire planning area;
- ~~Apply~~**Applying** a spatially limited (e.g., 100 km in North-South direction and 500 km in East-West direction) geoelectric field enhancement (12 V/km scaled to the planning area) over a portion(s) of the system, and ~~apply~~**applying** the benchmark GMD event over the rest of the system.
- Other methods to adjust the benchmark GMD event analysis for localized geoelectric field enhancement.

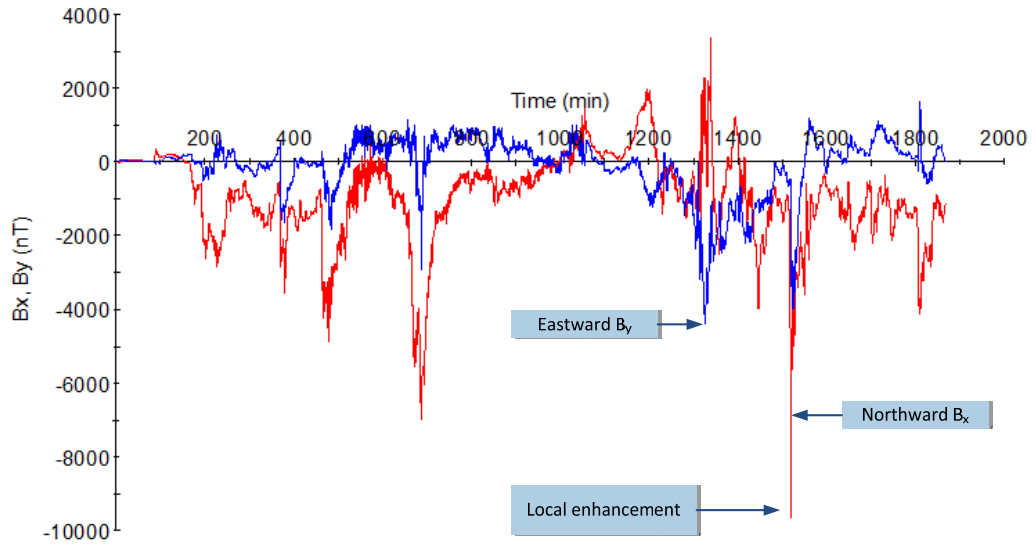
Given the current state of knowledge regarding the spatial extent of a local geomagnetic field enhancements, upper geographic boundaries, such as the values used in the approaches above, are reasonable but are not definitive.

## Local Enhancement Waveform

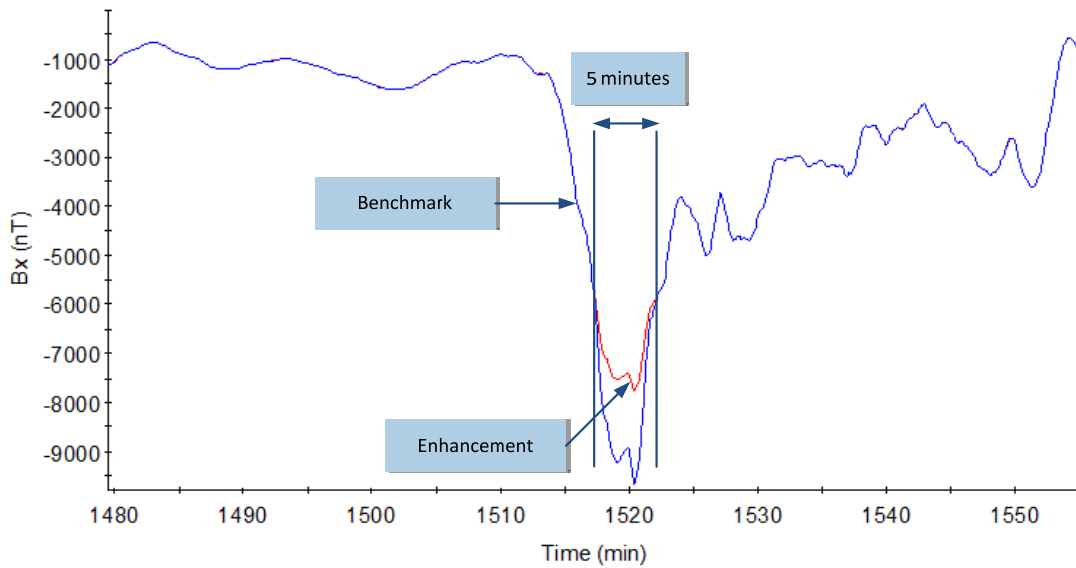
The supplemental geomagnetic field waveform was derived by modifying the benchmark GMD event waveform to emulate the observed events described above. The temporal location of the enhancement corresponds to the time of the benchmark event with the highest geoelectric field. The local enhancement was constructed by scaling linearly a 5-minute portion of the benchmark geomagnetic field so that the peak geoelectric field is 12 V/km at a geomagnetic latitude of 60° and reference earth model. Figure I-12 shows the benchmark geomagnetic field and Figure I-13 shows the supplemental event geomagnetic field. Figure I-14 expands the view into  $B_x$ , with and without the local enhancement. Figure I-15 is the corresponding expanded view of the geoelectric field magnitude with and without the local enhancement.



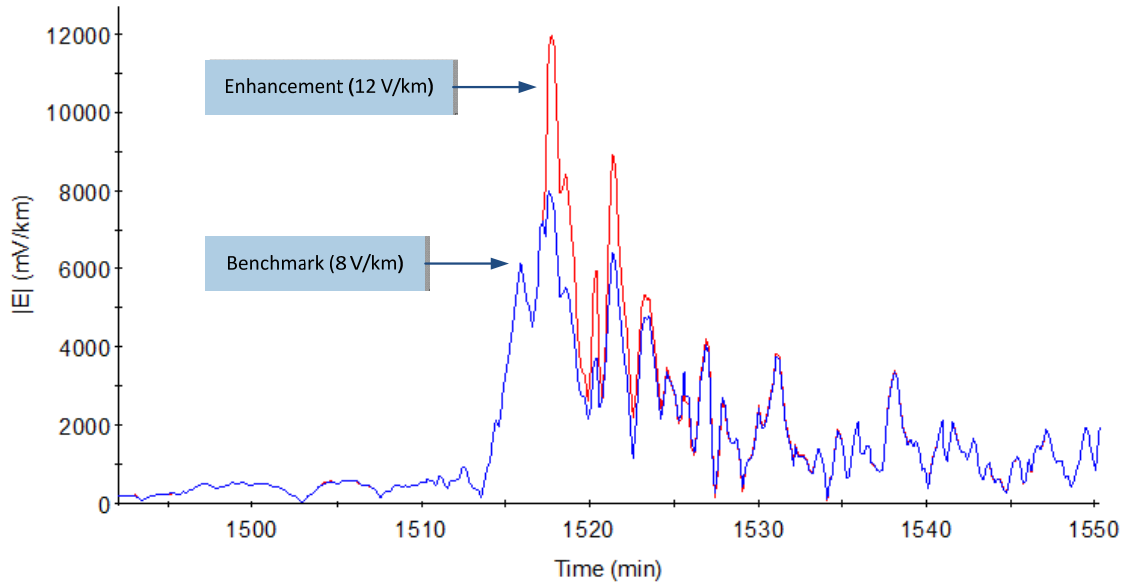
**Figure I-12: Benchmark Geomagnetic Field**  
Red  $B_x$  (Northward), Blue  $B_y$  (Eastward)



**Figure I-13: Supplemental Geomagnetic Field Waveform  
Red  $B_x$  (Northward), Blue  $B_y$  (Eastward)**



**Figure I-14: Red Benchmark  $B_x$  and Blue Supplemental  $B_x$  (Northward) – Expanded View**



**Figure I-15: Magnitude of the Geoelectric Field  
Benchmark Blue and Supplemental Red – Expanded View**

## Transformer Thermal Assessment

The local enhancement of the supplemental GMD event waveform can have a material impact on the temperature rise (hot-spot heating or metallic parts) even though the duration of the local enhancement is approximately five minutes. Thermal assessments based on the supplemental GMD event can be performed using the same methods employed for benchmark thermal assessments.<sup>10</sup>

<sup>10</sup> See Transformer Thermal Impact Assessment white paper: <http://www.nerc.com/pa/Stand/Pages/Project-2013-03-Geomagnetic-Disturbance-Mitigation.aspx> ~~<http://www.nerc.com/pa/Stand/Pages/Project-2013-03-Geomagnetic-Disturbance-Mitigation.aspx>~~

## Appendix II – Scaling the Supplemental GMD Event

The intensity of a GMD event depends on geographical considerations such as geomagnetic latitude and local earth conductivity [2].<sup>11</sup> Scaling factors for geomagnetic latitude take into consideration that the intensity of a GMD event varies according to latitude-based geographical location. Scaling factors for earth conductivity take into account that the induced geoelectric field depends on earth conductivity, and that different parts of the continent have different earth conductivity and deep earth structure.

Scaling the supplemental GMD event differs from the benchmark GMD event in two ways:

- $E_{\text{peak}}$  is 12 V/km instead of 8 V/km
- Beta factors for scaling the geoelectric field based on earth conductivity are different (see Table II-2)

More discussion, including example calculations, is contained in the Benchmark GMD Event Description white paper.

### Scaling the Geomagnetic Field

The supplemental GMD event is defined for geomagnetic latitude of 60° and it must be scaled to account for regional differences based on geomagnetic latitude. To allow usage of the supplemental geomagnetic field waveform in other locations, Table II-1 summarizes the scaling factor  $\alpha$  correlating peak geoelectric field to geomagnetic latitude as described illustrated in Figure II-1 [3]. This scaling factor  $\alpha$  has been obtained from a large number of global geomagnetic field observations of all major geomagnetic storms since the late 1980s [15]-[2717], and can be approximated with the empirical expression in (II.1):

$$\alpha = 0.001 \times e^{(0.115 \times L)} \quad (\text{II.1})$$

where  $L$  is the geomagnetic latitude in degrees and  $0.1 \leq \alpha \leq 1.0$ .

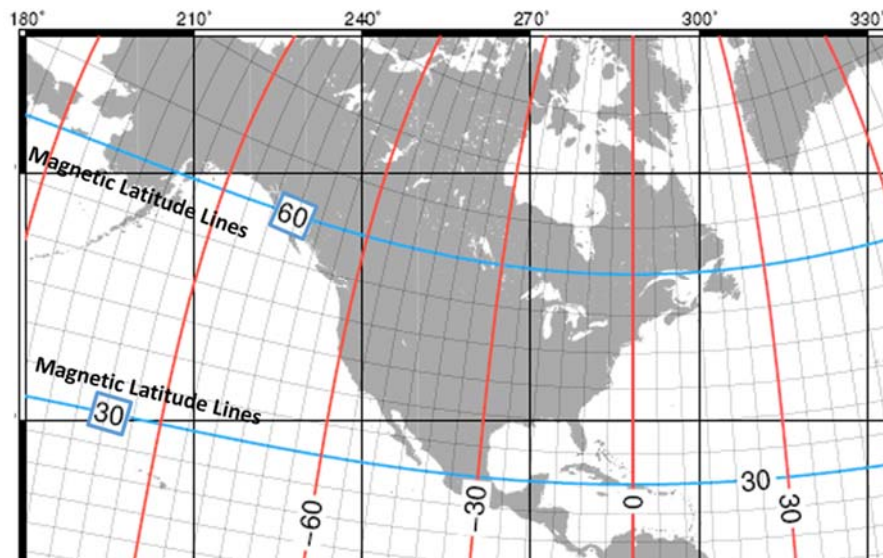


Figure II-1: Geomagnetic Latitude Lines in North America

<sup>11</sup> Geomagnetic latitude is analogous to geographic latitude, except that bearing is in relation to the magnetic poles, as opposed to the geographic poles. Geomagnetic phenomena are often best organized as a function of geomagnetic coordinates. Local earth conductivity refers to the electrical characteristics to depths of hundreds of km down to the earth's mantle. In general terms, lower ground conductivity results in higher geoelectric field amplitudes.

Table II-1: Geomagnetic Field Scaling Factors	
Geomagnetic Latitude (Degrees)	Scaling Factor1 ( $\alpha$ )
$\leq 40$	0.10
45	0.2
50	0.3
54	0.5
56	0.6
57	0.7
58	0.8
59	0.9
$\geq 60$	1.0

## Scaling the Goelectric Field

The supplemental GMD event is defined for the reference [QuebecQuébec](#) earth model provided in Table 1. This earth model has been used in many peer-reviewed technical articles [11, 15]. The peak goelectric field depends on the geomagnetic field waveform and the local earth conductivity. Ideally, the peak goelectric field,  $E_{peak}$ , is obtained by calculating the goelectric field from the scaled geomagnetic field waveform using the plane wave method and taking the maximum value of the resulting waveforms:

$$\begin{aligned}
 E_N &= (z(t)/\mu_0)^* \times B_E(t) \\
 E_N &= -(z(t)/\mu_0)^* \times B_N(t) \\
 E_{peak} &= \max\{|E_E(t), E_N(t)|\}
 \end{aligned}
 \tag{II.2}$$

where,

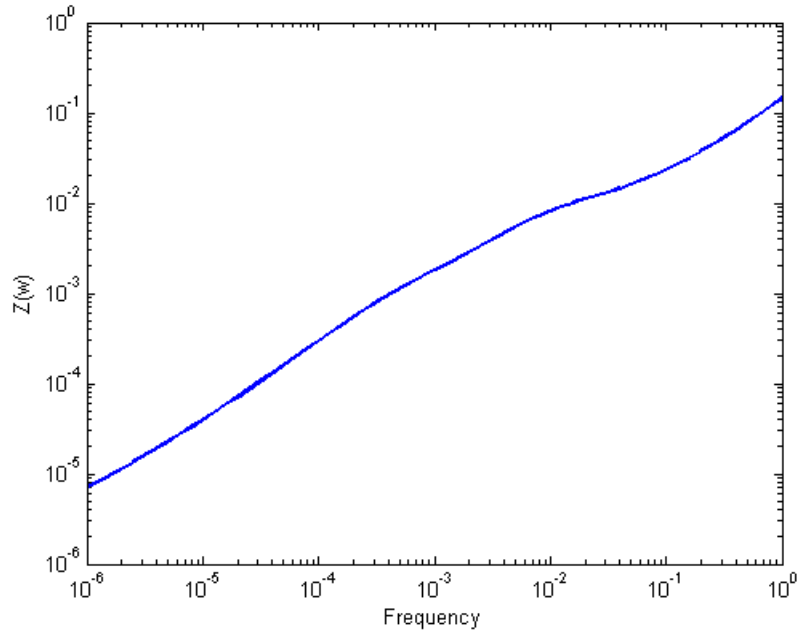
\*denotes convolution in the time domain,

$z(t)$  is the impulse response for the earth surface impedance calculated from the laterally uniform or 1D earth model,

$B_E(t)$ ,  $B_N(t)$  are the scaled Eastward and Northward geomagnetic field waveforms, [and](#)

$|E_E(t), E_N(t)|$  are the magnitudes of the calculated Eastward and Northward goelectric field  $E_E(t)$  and  $E_N(t)$ .

As noted previously, the response of the earth to  $B(t)$  (and  $dB/dt$ ) is frequency dependent. Figure II-2 shows the magnitude of  $Z(\omega)$  for the reference earth model.



**Figure II-2: Magnitude of the Earth Surface Impedance for the Reference Earth Model**

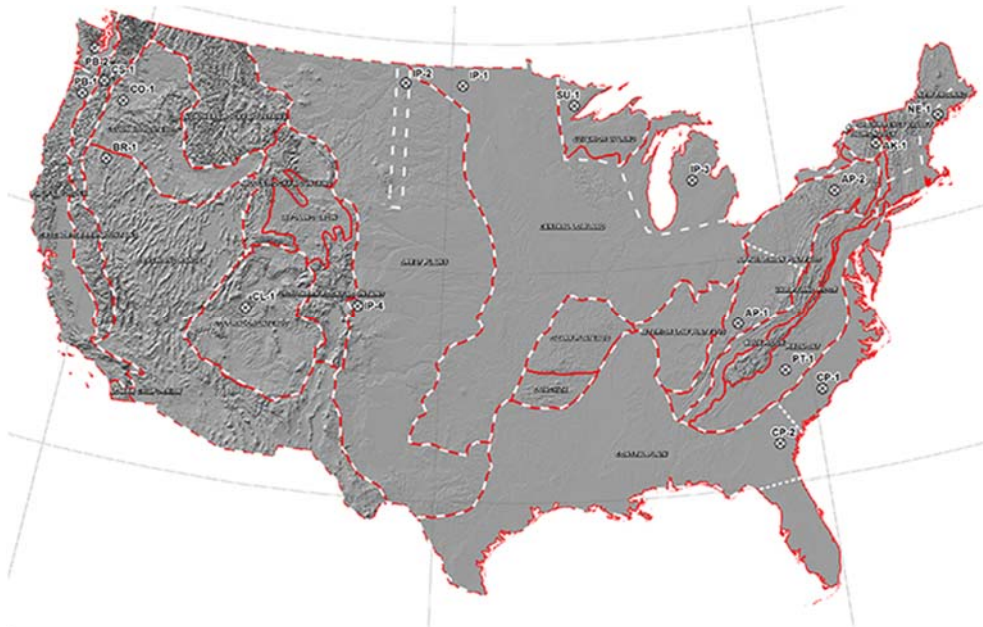
If a utility does not have the capability of calculating the waveform or time series for the geoelectric field, an earth conductivity scaling factor  $\beta_s$  can be obtained from Table II-2. Using  $\alpha$  and  $\beta$ , the peak geoelectric field  $E_{peak}$  for a specific service territory shown in Figure II-3 can be obtained using (II.3).

$$E_{peak} = 12 \times \alpha \times \beta_s (V/km) \quad (II.3)$$

It should be noted that (II.3) is an approximation based on the following assumptions:

- The earth models used to calculate Table II-2 for the United States are from published information available on the USGS website. These scaling factors are slightly lower than the ones in the benchmark because the supplemental benchmark waveform has a higher frequency content at the time of the local enhancement.
- The models used to calculate Table II-2 for Canada were obtained from NRCAN and reflect the average structure for large regions. When models are developed for sub-regions, there will be variance (to a greater or lesser degree) from the average model. For instance, detailed models for Ontario have been developed by NRCAN and consist of seven major sub-regions.
- The conductivity scaling factor  $\beta_s$  is calculated as the quotient of the local geoelectric field peak amplitude in a physiographic region with respect to the reference peak amplitude value of 12 V/km. Both geoelectric field peak amplitudes are calculated using the supplemental geomagnetic field time series. If a different geomagnetic field time series were used, the calculated scaling factors ( $\beta$ ) would be different than the values in Table II-2 because the frequency content of storm maxima is, in principle, different for every storm. If a utility has technically-sound earth models for its service territory and sub-regions thereof, then the use of such earth models is preferable to estimate  $E_{peak}$ .
- When a ground conductivity model is not available the planning entity should use the largest  $\beta_s$  factor of adjacent physiographic regions or a technically-justified value.

### Physiographic Regions of the Continental United States



### Physiographic Regions of Canada



Figure II-3: Physiographic Regions of North America

<b>Table II-2 Supplemental Geoelectric Field Scaling Factors</b>	
<b>Earth model</b>	<b>Scaling Factor (<math>\beta</math>)</b>
AK1A	0.51
AK1B	0.51
AP1	0.30
AP2	0.78
BR1	0.22
CL1	0.73
CO1	0.25
CP1	0.77
CP2	0.86
FL1	0.73
CS1	0.37
IP1	0.90
IP2	0.25
IP3	0.90
IP4	0.35
NE1	0.77
PB1	0.55
PB2	0.39
PT1	1.19
SL1	0.49
SU1	0.90
BOU	0.24
FBK	0.56
PRU	0.22
BC	0.62
PRAIRIES	0.88
SHIELD	1.0
ATLANTIC	0.76



## References

---

- [1] *High-Impact, Low-Frequency Event Risk to the North American Bulk Power System*, A Jointly-Commissioned Summary Report of the North American Reliability Corporation and the U.S. Department of Energy's November 2009 Workshop.
- [2] Application Guide: Computing Geomagnetically-Induced Current in the Bulk-Power System, NERC. December 2013. [http://www.nerc.com/comm/PC/Geomagnetic%20Disturbance%20Task%20Force%20GMDTF%202013/GIC%20Application%20Guide%202013\\_approved.pdf](http://www.nerc.com/comm/PC/Geomagnetic%20Disturbance%20Task%20Force%20GMDTF%202013/GIC%20Application%20Guide%202013_approved.pdf) NERC.
- [3] ~~Kuan Zheng, Risto Boteler, D. H.; Pirjola, David Boteler, Lian-guang R. J.; Liu, L.; and Zheng, K.;~~ "Geoelectric Fields Due to Small-Scale and Large-Scale Source Currents", *IEEE Transactions on Power Delivery*, Vol. 28, No. 1, January 2013, pp. 442-449.
- [4] Boteler, D. H. "Geomagnetically Induced Currents: Present Knowledge and Future Research", *IEEE Transactions on Power Delivery*, Vol. 9, No. 1, January 1994, pp. 50-58.
- [5] Boteler, D. H. "Modeling Geomagnetically Induced Currents Produced by Realistic and Uniform Electric Fields", *IEEE Transactions on Power Delivery*, Vol. 13, No. 4, January 1998, pp. 1303-1308.
- [6] ~~J. L. Gilbert, W. A. J. L.; Radasky, E. B. W. A.; and Savage, E. B.~~ "A Technique for Calculating the Currents Induced by Geomagnetic Storms on Large High Voltage Power Grids", *Electromagnetic Compatibility (EMC)*. 2012 IEEE International Symposium on.
- [7] *How to Calculate Electric Fields to Determine Geomagnetically-Induced Currents*. EPRI, Palo Alto, CA: 2013. 3002002149.
- [8] ~~Pirjola, R.;~~ Pulkkinen, A., ~~R. Pirjola,;~~ and ~~A. Viljanen, V.~~ Statistics of extreme geomagnetically induced current events, *Space Weather*, 6, S07001, doi:10.1029/2008SW000388, 2008.
- [9] Boteler, D. H., Assessment of geomagnetic hazard to power systems in Canada, *Nat. Hazards*, 23, 101–120, 2001.
- [10] Finnish Meteorological Institute's IMAGE magnetometer chain data available at: <http://image.gsfc.nasa.gov/>
- [11] Boteler, D. H., and ~~R. J. Pirjola, R. J.~~ The complex-image method for calculating the magnetic and electric fields produced at the surface of the Earth by the auroral electrojet, *Geophys. J. Int.*, 132(1), 31–40, 1998.
- [12] Coles, ~~Stuart (2001), S.~~ An Introduction to Statistical Modelling of Extreme Values. Springer. 2001.
- [13] ~~Clarke, E.; Mckay, A.;~~ Pulkkinen, A., ~~A.;~~ and Thomson, ~~E. Clarke, and A. Mckay, A.~~ April 2000 geomagnetic storm: ionospheric drivers of large geomagnetically induced currents, *Annales Geophysicae*, 21, 709-717, 2003.
- [14] ~~Lindahl, S.;~~ Pirjola, R. J.; Pulkkinen, A., ~~S. Lindahl, A.;~~ and Viljanen, ~~and R. Pirjola, A.~~ Geomagnetic storm of 29–31 October 2003: Geomagnetically induced currents and their relation to problems in the

- Swedish high-voltage power transmission system, *Space Weather*, 3, S08C03, doi:10.1029/2004SW000123, 2005.
- [15] ~~Pulkkinen, A., E. Beggan, C.; Bernabeu, J.E.; Eichner, C. Beggan, J.; Pulkkinen, A.; and A. Thomson, A.~~ Generation of 100-year geomagnetically induced current scenarios, *Space Weather*, Vol. 10, S04003, doi:10.1029/2011SW000750, 2012.
- [16] ~~Crowley, G.; Ngwira, C., A.; Pulkkinen, F.A.; and Wilder, and G. Crowley, F.~~ Extended study of extreme geoelectric field event scenarios for geomagnetically induced current applications, *Space Weather*, Vol. 11, 121–131, doi:10.1002/swe.20021, 2013.
- [17] ~~Thomson, A., S. Dawson, E.; Reay, S.; and E. Dawson Thomson, A.~~ Quantifying extreme behavior in geomagnetic activity, *Space Weather*, 9, S10001, doi:10.1029/2011SW000696, 2011.

# Screening Criterion for Transformer Thermal Impact Assessment White Paper

## TPL-007-2 Transmission System Planned Performance for Geomagnetic Disturbance Events

### Summary

Proposed TPL-007-2 includes requirements for entities to perform two types of geomagnetic disturbance (GMD) Vulnerability Assessments to evaluate the potential impacts of GMD events on the Bulk Electric System (BES):

- The benchmark GMD Vulnerability Assessment is based on the benchmark GMD event associated with TPL-007-1 which standard was approved by the Federal Energy Regulatory Commission (FERC) in Order No. 830 in September 2016. The benchmark GMD event is derived from spatially-averaged geoelectric field values to address potential wide-area effects that could be caused by a severe 1-in-100 year GMD event.<sup>1</sup>
- The supplemental GMD Vulnerability Assessment, based on the supplemental GMD event, is used by entities to evaluate risks that localized peaks in geomagnetic field during a severe GMD event "could potentially affect the reliable operation of the Bulk-Power System".<sup>2</sup> Localized enhancements of geomagnetic field can result in geoelectric field values above the spatially-averaged benchmark in a local area.

The standard requires transformer thermal impact assessments to be performed on BES power transformers with high side, wye-grounded windings with terminal voltage greater than 200 kV. Identified BES transformers must undergo a thermal impact assessment if the maximum effective geomagnetically-induced current (GIC) in the transformer is equal to or greater than:

- 75 A per phase for the benchmark GMD event
- 85 A per phase for the supplemental GMD event

Based on published power transformer measurement data as described below, the respective screening criteria are conservative and, although derived from measurements in single-phase units, are applicable to transformers with all core types (e.g., three-limb, three-phase).

<sup>1</sup> See *Benchmark Geomagnetic Disturbance Event Description* white paper, May 12, 2016. Filed by NERC in Docket No. RM15-11 on June 28, 2016.

<sup>2</sup> See Order No. 830, P. 47. In Order No. 830, FERC directed NERC to develop modifications to the benchmark GMD event, included in TPL-007-1, such that assessments would not be based solely on spatially averaged data. The characteristics of a GMD event for this assessment are in the Supplemental GMD Event Description white paper.

Outside of the differing screening criteria, the only difference between the thermal impact assessment for the benchmark GMD event and the supplemental GMD event is that a different waveform is used, therefore peak metallic hot spot temperatures are slightly different for a given GIC in the transformer.

### Justification for the Benchmark Screening Criterion

Applicable entities are required to carry out a thermal assessment with  $GIC(t)$  calculated using the benchmark GMD event geomagnetic field time series or waveform for effective GIC values above a screening threshold. The calculated  $GIC(t)$  for every transformer will be different because the length and orientation of transmission circuits connected to each transformer will be different even if the geoelectric field is assumed to be uniform. However, for a given thermal model and maximum effective GIC there are upper and lower bounds for the peak hot spot temperatures. These are shown in Figure 1 using three available thermal models based on direct temperature measurements.

The results shown in Figure 1 summarize the peak metallic hot spot temperatures when  $GIC(t)$  is calculated using (1), and systematically varying  $GIC_E$  and  $GIC_N$  to account for all possible orientation of circuits connected to a transformer. The transformer GIC (in A/phase) for any value of  $E_E(t)$  and  $E_N(t)$  can be calculated using equation (1) from reference [1].

$$GIC(t) = |E(t)| \times \{GIC_E \times \sin(\varphi(t)) + GIC_N \times \cos(\varphi(t))\} \quad (1)$$

where

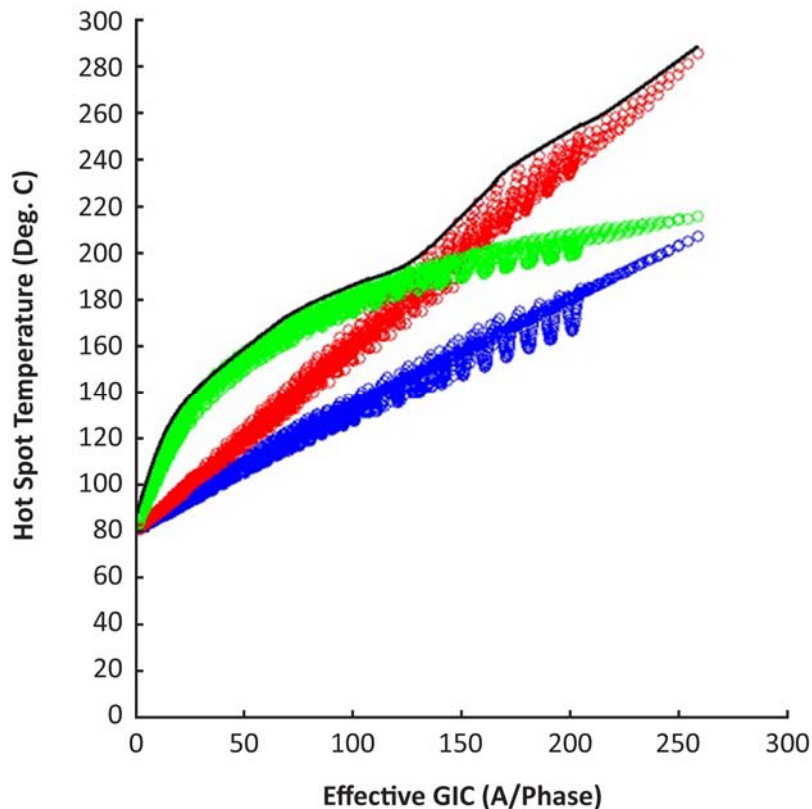
$$|E(t)| = \sqrt{E_N^2(t) + E_E^2(t)} \quad (2)$$

$$\varphi(t) = \tan^{-1} \left( \frac{E_E(t)}{E_N(t)} \right) \quad (3)$$

$$GIC(t) = E_E(t) \times GIC_E + E_N(t) \times GIC_N \quad (4)$$

$GIC_N$  is the effective GIC due to a northward geoelectric field of 1 V/km, and  $GIC_E$  is the effective GIC due to an eastward geoelectric field of 1 V/km. The units for  $GIC_N$  and  $GIC_E$  are A/phase per V/km.

It should be emphasized that with the thermal models used and the benchmark GMD event geomagnetic field waveform, peak metallic hot spot temperatures will lie below the envelope shown in black in Figure 1. The x-axis in Figure 1 corresponds to the absolute value of peak  $GIC(t)$ . Effective maximum GIC for a transformer corresponds to a worst-case geoelectric field orientation, which is network-specific. Figure 1 represents a possible range, not the specific thermal response for a given effective GIC and orientation.



**Figure 1: Metallic hot spot temperatures calculated using the benchmark GMD event**

Red: SVC coupling transformer model [2] Blue: Fingrid model [3] Green: Autotransformer model [4]

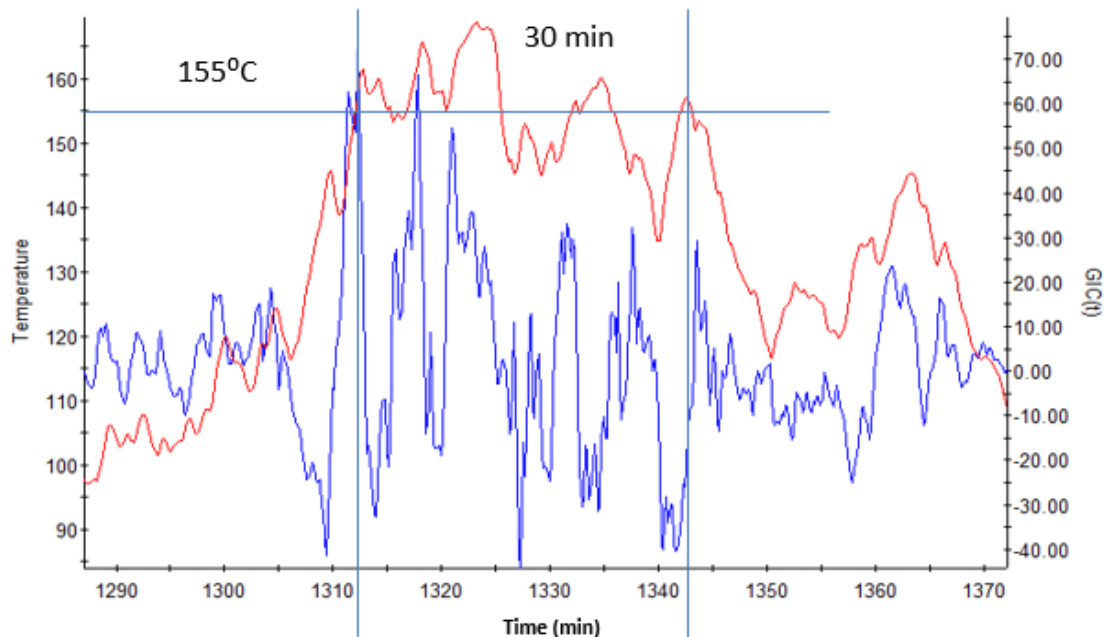
Consequently, with the most conservative thermal models known at this point in time, the peak metallic hot spot temperature obtained with the benchmark GMD event waveform assuming an effective GIC magnitude of 75 A per phase will result in a peak temperature between 160°C and 172°C when the bulk oil temperature is 80°C (full load bulk oil temperature). The upper boundary of 172°C remains well below the metallic hot spot 200°C threshold for short-time emergency loading suggested in IEEE Std C57.91-2011 – Guide for Loading Mineral-Oil-Immersed Transformers and Step-Voltage Regulators [5].

The selection of the 75 A per phase screening threshold is based on the following considerations:

- A thermal assessment, which uses the most conservative thermal models known to date, indicates that a GIC of 75A will not result in peak metallic hot spot temperatures above 172°C. Transformer thermal assessments should not be required by Reliability Standards when results will fall well below IEEE Std C57.91-2011 limits.

- Applicable entities may choose to carry out a thermal assessment when the effective GIC is below 75 A per phase to take into account the age or condition of specific transformers where IEEE Std C57.91- 2011 limits could be assumed to be lower than 200°C. Refer to IEEE Standard C57.163-2015 Guide for Establishing Power Transformer Capability while under Geomagnetic Disturbances for additional information [6].
- The models used to determine the 75 A per phase screening threshold are known to be conservative at higher values of effective GIC, especially the SVC coupling transformer model in [2].
- Thermal models in peer-reviewed technical literature, especially those calculated models without experimental validation, are less conservative than the models used to determine the screening threshold. Therefore, a technically-justified thermal assessment for effective GIC below 75 A per phase using the benchmark GMD event geomagnetic field waveform will always result in a “pass” on the basis of the state of the knowledge at this point in time.
- Based on simulations, the 75 A per phase screening threshold will result in a maximum instantaneous peak hot spot temperature of 172°C. However, IEEE Std C57.91-2011 limits assume short term emergency operation (typically 30 minutes). As illustrated in Figure 2, simulations of the 75 A per phase screening threshold result in 30-minute duration hot spot temperatures of about 155°C. The threshold provides an added measure of conservatism in not taking into account the duration of hot spot temperatures.
- The models used in the determination of the threshold are conservative but technically justified.
- Winding hot spots are not the limiting factor in terms of hot spots due to half-cycle saturation, therefore the screening criterion is focused on metallic part hot spots only.

The 75 A per phase screening threshold was determined using single-phase transformers, but is being applied as a screening criterion for all types of transformer construction. While it is known that some transformer types such as three-limb, three-phase transformers are intrinsically less susceptible to GIC, it is not known by how much, on the basis of experimentally-supported models.



**Figure 2: Metallic hot spot temperatures calculated using the benchmark GMD event**

Red: metallic hot spot temperature

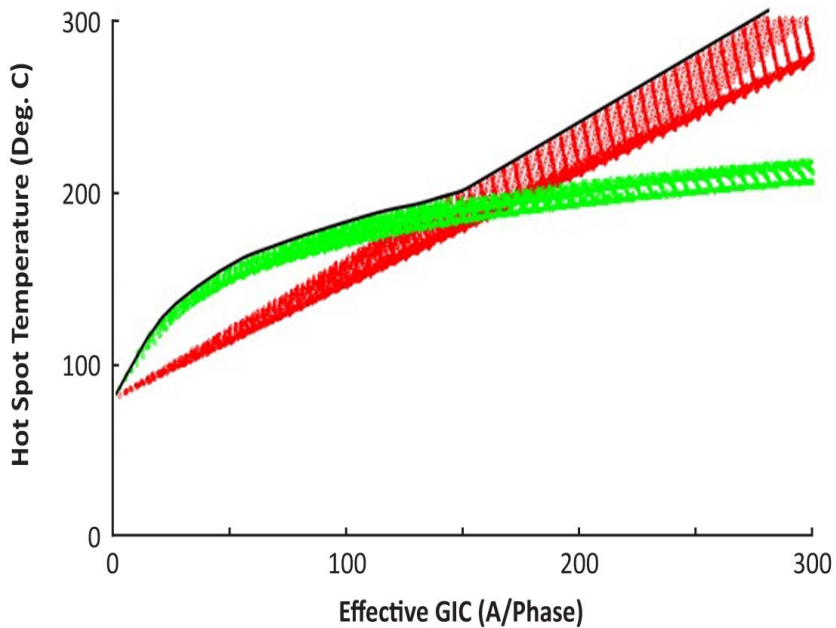
Blue: GIC(t) that produces the maximum hot spot temperature with peak GIC(t) scaled to 75 A/phase

## Justification for the Supplemental Screening Criterion

As in the case for the benchmark GMD event discussed above, applicable entities are required to carry out thermal assessments on their BES power transformers when the effective GIC values are above a screening threshold. GIC(t) for supplemental thermal assessments is calculated using the supplemental GMD event geomagnetic field time series or waveform.

Using the supplemental GMD event waveform, a thermal analysis was completed for the two transformers that were limiting for the benchmark waveform. The results are shown in Figure 3. Peak metallic hot spot temperatures for the supplemental GMD event will lie below the envelope shown by the black line trace in Figure 3. Because the supplemental waveform has a sharper peak, the peak metallic hot spot temperatures are slightly lower than those associated with the benchmark waveform. Applying the most conservative thermal models known at this point in time, the peak metallic hot spot temperature obtained with the supplemental GMD event waveform assuming an effective GIC magnitude of 85 A per phase will result in a peak temperature of 172°C when the bulk oil temperature is 80°C (full load bulk oil temperature).<sup>3</sup> Thus, 85 A per phase is the screening level for the supplemental waveform.

<sup>3</sup> The temperature 172°C was selected as the screening criteria for the benchmark waveform as described in the preceding section.



**Figure 3: Metallic hot spot temperatures calculated using the supplemental GMD event**  
Red: SVC coupling transformer model [2] Green: Autotransformer model [4]



## Appendix I - Transformer Thermal Models Used in the Development of the Screening Criteria

The envelope used for thermal screening (Figure 1) is derived from two thermal models. The first is based on laboratory measurements carried out on 500/16.5 kV 400 MVA single-phase Static Var Compensator (SVC) coupling transformer [2]. Temperature measurements were carried out at relatively small values of GIC (see Figure I-1). The asymptotic thermal response for this model is the linear extrapolation of the known measurement values. Although the near-linear behavior of the asymptotic thermal response is consistent with the measurements made on a Fingrid 400 kV 400 MVA five-leg core-type fully-wound transformer [3] (see Figures I-2 and I-3), the extrapolation from low values of GIC is very conservative, but reasonable for screening purposes.

The second transformer model is based on a combination of measurements and modeling for a 400 kV 400 MVA single-phase core-type autotransformer [4] (see Figures I-4 and I-5). The asymptotic thermal behavior of this transformer shows a “down-turn” at high values of GIC as the tie plate increasingly saturates but relatively high temperatures for lower values of GIC. The hot spot temperatures are higher than for the two other models for GIC less than 125 A per phase.

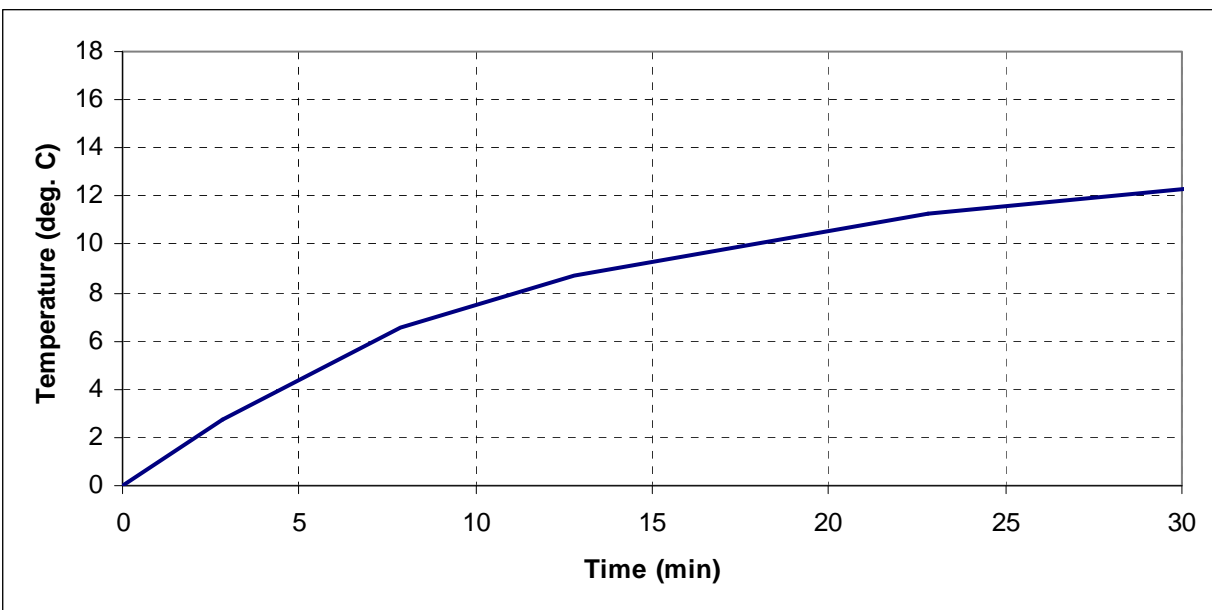


Figure I-1: Thermal step response of the tie plate of a 500 kV 400 MVA single-phase SVC coupling transformer to a 5 A per phase dc step

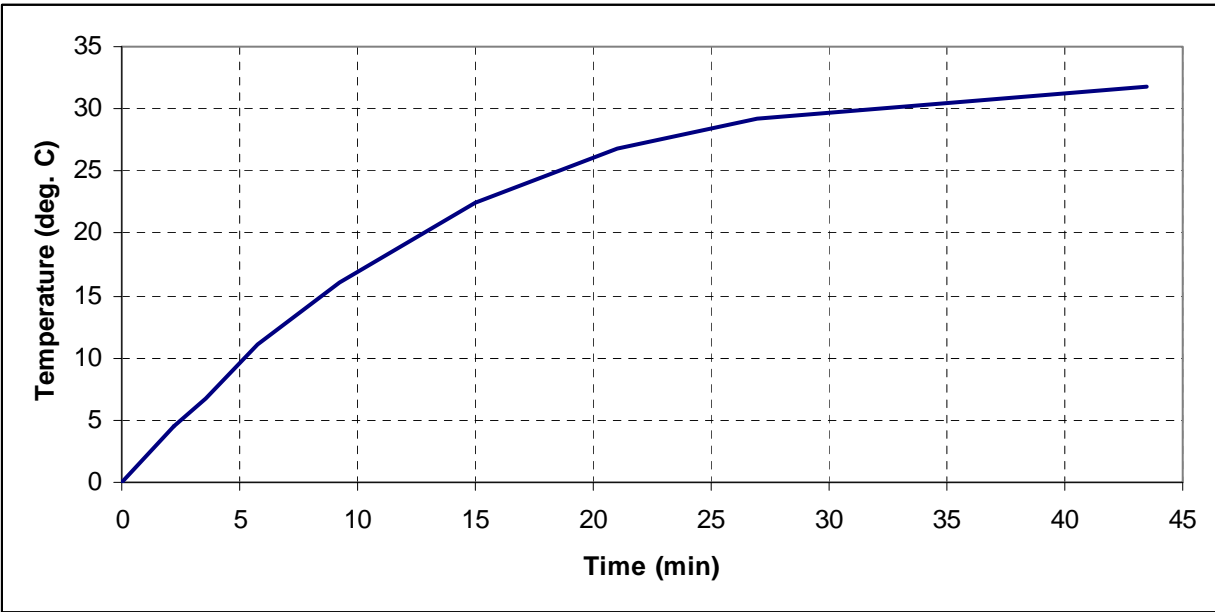


Figure I-2: Step thermal response of the top yoke clamp of a 400 kV 400 MVA five-leg core-type fully-wound transformer to a 16.67 A per phase dc step

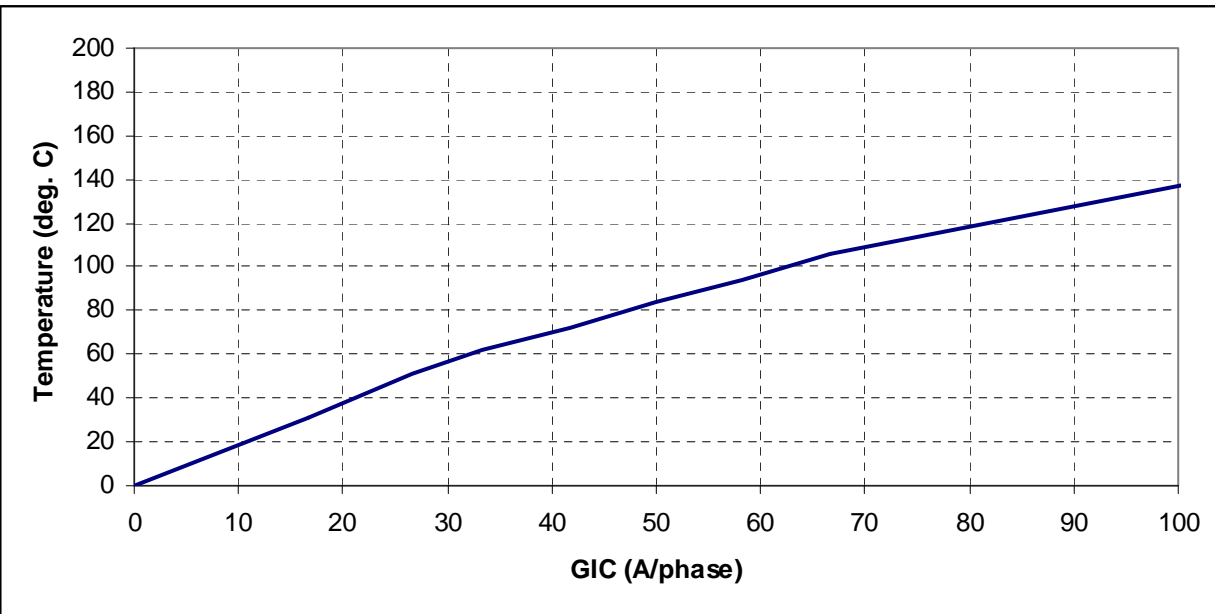


Figure I-3: Asymptotic thermal response of the top yoke clamp of a 400 kV 400 MVA five-leg core-type fully-wound transformer

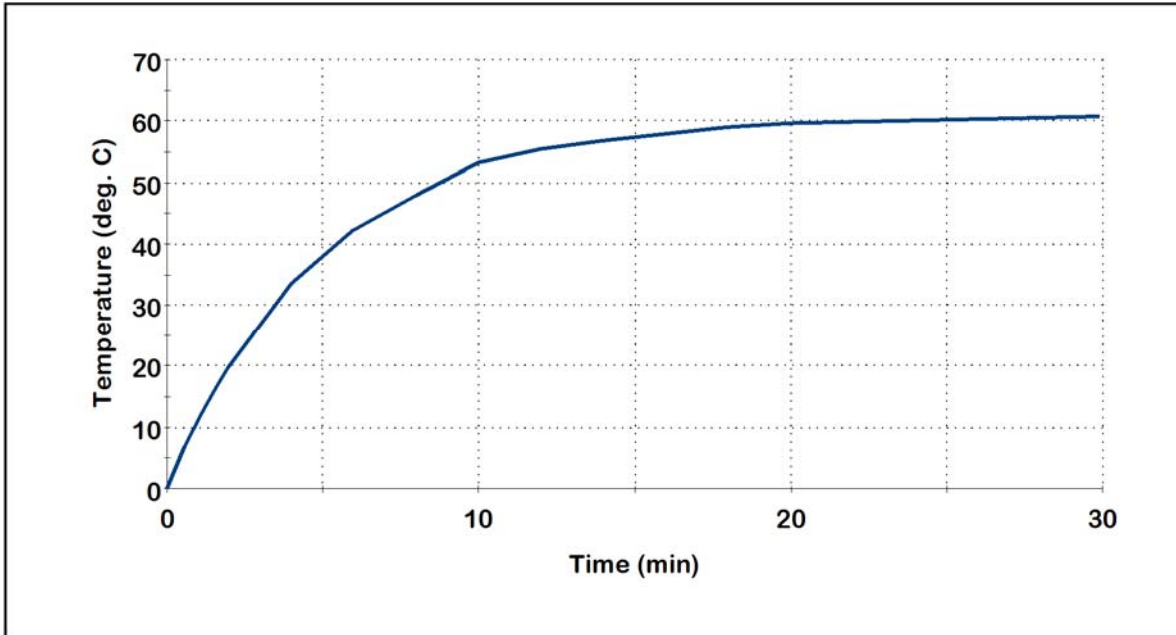


Figure I-4: Step thermal response of the tie plate of a 400 kV 400 MVA single-phase core-type autotransformer to a 10 A per phase dc step

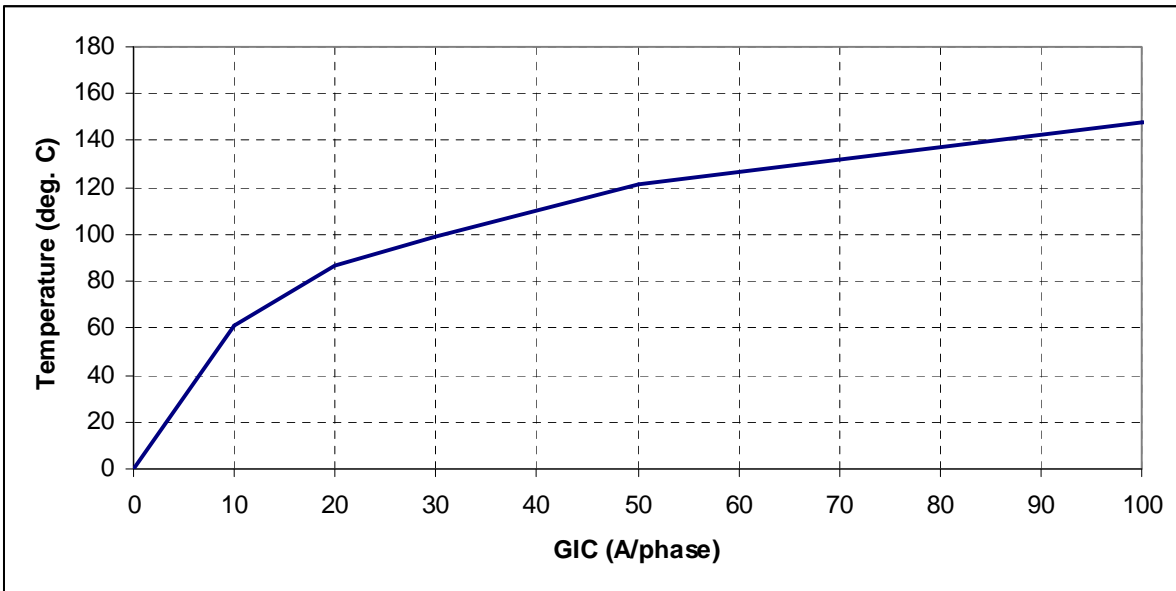


Figure I-5: Asymptotic thermal response of the tie plate of a 400 kV 400 MVA single-phase core-type autotransformer

The envelope in Figure 1 can be used as a conservative thermal assessment for effective GIC values of associated with the benchmark waveform and reference earth model (see Table 1).

Effective GIC (A/phase)	Metallic hot spot Temperature (°C)	Effective GIC (A/phase)	Metallic hot spot Temperature (°C)
0	80	100	182
10	107	110	186
20	128	120	190
30	139	130	193
40	148	140	204
50	157	150	213
60	169	160	221
70	170	170	230
75	172	180	234
80	175	190	241
90	179	200	247

For instance, if effective GIC is 130 A per phase and oil temperature is assumed to be 80°C, peak hot spot temperature is 193°C. This value is below the 200°C IEEE Std C57.91-2011 threshold for short time emergency loading and this transformer will have passed the thermal assessment. If the full heat run oil temperature is 67°C at maximum ambient temperature, then 150 A per phase of effective GIC translates into a peak hot spot temperature of 200°C and the transformer will have passed. If the limit is lowered to 180°C to account for the condition of the transformer, then this would be an indication to “sharpen the pencil” and perform a detailed assessment. Some methods are described in Reference [1].

The temperature envelope in Figure 1 corresponds to the values of effective GIC that result in the highest temperature for the benchmark GMD event. Different values of effective GIC could result in lower temperatures using the same model. For instance, the difference in upper and lower bounds of peak temperatures for the SVC coupling transformer model for 150 A per phase is approximately 30°C. In this case, GIC(t) should be generated to calculate the peak temperatures for the actual configuration of the transformer within the system as described in Reference [1]. Alternatively, a more precise thermal assessment could be carried out with a thermal model that more closely represents the thermal behavior of the transformer under consideration.

Similar to the discussion above, the envelope in Figure 3 can be used as a conservative thermal assessment for effective GIC values of associated with the supplemental waveform (see Table 2). The supplemental waveform has a sharper peak; therefore, the peak metallic hot spot temperatures associated with the supplemental waveform for the same peak current are slightly lower than those associated with the

benchmark waveform. In other words, for the same peak current value, the duration is relatively shorter with the supplemental waveform, and shorter duration means lower temperature. However, higher peak currents will occur with the supplemental benchmark, therefore, higher peak hot spot temperatures will occur. Comparing Tables 1 and 2 shows the magnitude of this difference.

<b>Effective GIC (A/phase)</b>	<b>Metallic hot spot Temperature (°C )</b>	<b>Effective GIC(A/phase)</b>	<b>Metallic hot spot Temperature (°C )</b>
0	80	120	188
10	107	130	191
20	124	140	194
30	137	150	198
40	147	160	203
50	156	170	209
60	161	180	214
70	162	190	229
75	165	200	237
80	169	220	248
85	172	230	253
90	177	250	276
100	181	275	298
110	185	300	316

## References

- [1] Transformer Thermal Impact Assessment white paper. Developed by the Project 2013-03 (Geomagnetic Disturbance) standard drafting team. October 2017. Available at: <http://www.nerc.com/pa/stand/Pages/TPL0071RI.aspx>
- [2] Marti, L; Rezaei-Zare, A.; and Narang, A. "Simulation of Transformer Hotspot Heating due to Geomagnetically Induced Currents." *IEEE Transactions on Power Delivery*, vol.28, no.1, pp.320-327, Jan. 2013.
- [3] Lahtinen, M. and Elovaara, J. "GIC occurrences and GIC test for 400 kV system transformer". *IEEE Transactions on Power Delivery*, Vol. 17, No. 2. April 2002.
- [4] Raith, J. and Ausserhofer, S. "GIC Strength verification of Power Transformers in a High Voltage Laboratory", GIC Workshop, Cape Town, April 2014
- [5] "IEEE Guide for Loading Mineral-Oil-Immersed Transformers and Step-Voltage Regulators." IEEE Std C57.91-2011 (Revision of IEEE Std C57.91-1995).
- [6] "IEEE Guide for Establishing Power Transformer Capability while under Geomagnetic Disturbances." IEEE Std C57.163-2015.

# Screening Criterion for Transformer Thermal Impact Assessment White Paper

~~Project 2013-03 (Geomagnetic Disturbance Mitigation)~~

TPL-007-2 Transmission System Planned Performance for  
Geomagnetic Disturbance Events

## Summary

Proposed TPL-007-2 includes requirements for entities to perform two types of geomagnetic disturbance (GMD) Vulnerability Assessments to evaluate the potential impacts of GMD events on the Bulk Electric System (BES):

- The benchmark GMD Vulnerability Assessment is based on the benchmark GMD event associated with TPL-007-1 which standard was approved by the Federal Energy Regulatory Commission (FERC) in Order No. 830 in September 2016. The benchmark GMD event is derived from spatially-averaged geoelectric field values to address potential wide-area effects that could be caused by a severe 1-in-100 year GMD event.<sup>1</sup>
- The supplemental GMD Vulnerability Assessment, based on the supplemental GMD event, is used by entities to evaluate risks that localized peaks in geomagnetic field during a severe GMD event "could potentially affect the reliable operation of the Bulk-Power System".<sup>2</sup> Localized enhancements of geomagnetic field can result in geoelectric field values above the spatially-averaged benchmark in a local area.

The standard requires transformer thermal impact assessments to be performed on BES power transformers with high side, wye-grounded windings with terminal voltage greater than 200 kV. Identified BES transformers must undergo a thermal impact assessment if the maximum effective geomagnetically-induced current (GIC) in the transformer is equal to or greater than:

- 75 A per phase for the benchmark GMD event
- 85 A per phase for the supplemental GMD event

<sup>1</sup> See *Benchmark Geomagnetic Disturbance Event Description* white paper, May 12, 2016. Filed by NERC in Docket No. RM15-11 on June 28, 2016.

<sup>2</sup> See Order No. 830, P. 47. ~~On September 22, 2016~~ In Order No. 830, FERC directed NERC to develop modifications to the benchmark GMD event, included in TPL-007-1, such that assessments would not be based solely on spatially averaged data. The characteristics of a GMD event for this assessment are in the Supplemental GMD Event Description white paper.

Based on published power transformer measurement data as described below, the respective screening criteria are conservative and, although derived from measurements in single-phase units, are applicable to transformers with all core types (e.g., three-limb, three-phase).

Outside of the differing screening criteria, the only difference between the thermal impact assessment for the benchmark GMD event and the supplemental GMD event is that a different waveform is used, therefore peak metallic hot spot temperatures are slightly different for a given GIC in the transformer.

### Justification for the Benchmark Screening Criterion

Applicable entities are required to carry out a thermal assessment with  $GIC(t)$  calculated using the benchmark GMD event geomagnetic field time series or waveform for effective GIC values above a screening threshold. The calculated  $GIC(t)$  for every transformer will be different because the length and orientation of transmission circuits connected to each transformer will be different even if the geoelectric field is assumed to be uniform. However, for a given thermal model and maximum effective GIC there are upper and lower bounds for the peak hot spot temperatures. These are shown in Figure 1 using three available thermal models based on direct temperature measurements.

The results shown in Figure 1 summarize the peak metallic hot spot temperatures when  $GIC(t)$  is calculated using (1), and systematically varying  $GIC_E$  and  $GIC_N$  to account for all possible orientation of circuits connected to a transformer. The transformer GIC (in A/phase) for any value of  $E_E(t)$  and  $E_N(t)$  can be calculated using equation (1) from reference [1].

$$GIC(t) = |E(t)| \times \{GIC_E \times \sin(\varphi(t)) + GIC_N \times \cos(\varphi(t))\} \quad (1)$$

where

$$|E(t)| = \sqrt{E_N^2(t) + E_E^2(t)} \quad (2)$$

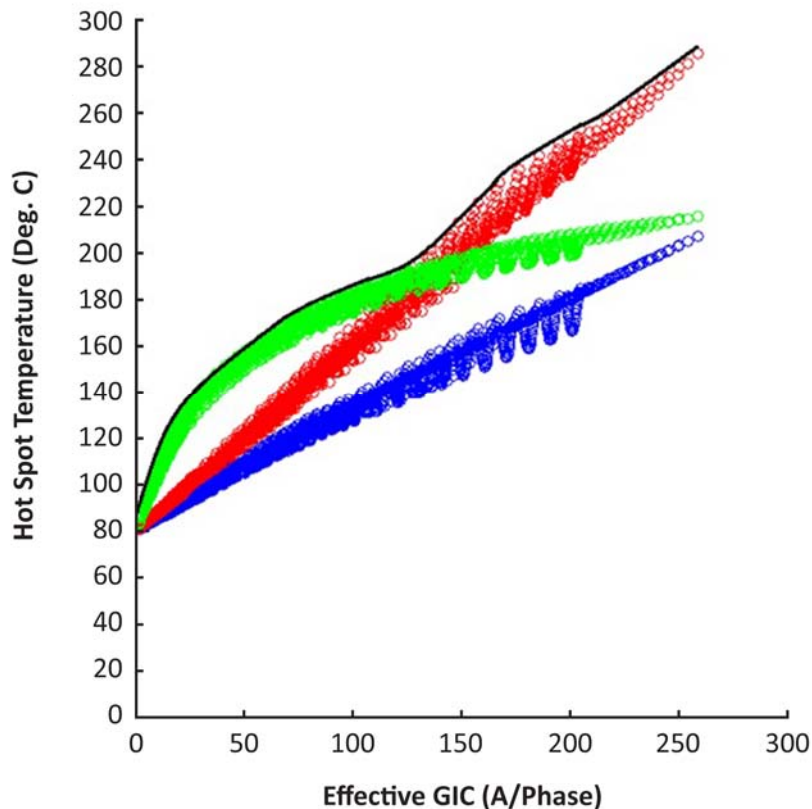
$$\varphi(t) = \tan^{-1} \left( \frac{E_E(t)}{E_N(t)} \right) \quad (3)$$

$$GIC(t) = E_E(t) \times GIC_E + E_N(t) \times GIC_N \quad (4)$$

$GIC_N$  is the effective GIC due to a northward geoelectric field of 1 V/km, and  $GIC_E$  is the effective GIC due to an eastward geoelectric field of 1 V/km. The units for  $GIC_N$  and  $GIC_E$  are A/phase per V/km.

It should be emphasized that with the thermal models used and the benchmark GMD event geomagnetic field waveform, peak metallic hot spot temperatures will lie below the envelope shown in black in Figure 1. The x-axis in Figure 1 corresponds to the absolute value of peak  $GIC(t)$ . Effective maximum GIC for a transformer corresponds to a worst-case geoelectric field orientation, which is network-specific. Figure 1 represents a possible range, not the specific thermal response for a given effective GIC and orientation.





**Figure 1: Metallic hot spot temperatures calculated using the benchmark GMD event**

Red: SVC coupling transformer model [2] Blue: Fingrid model [3] Green: Autotransformer model [4]

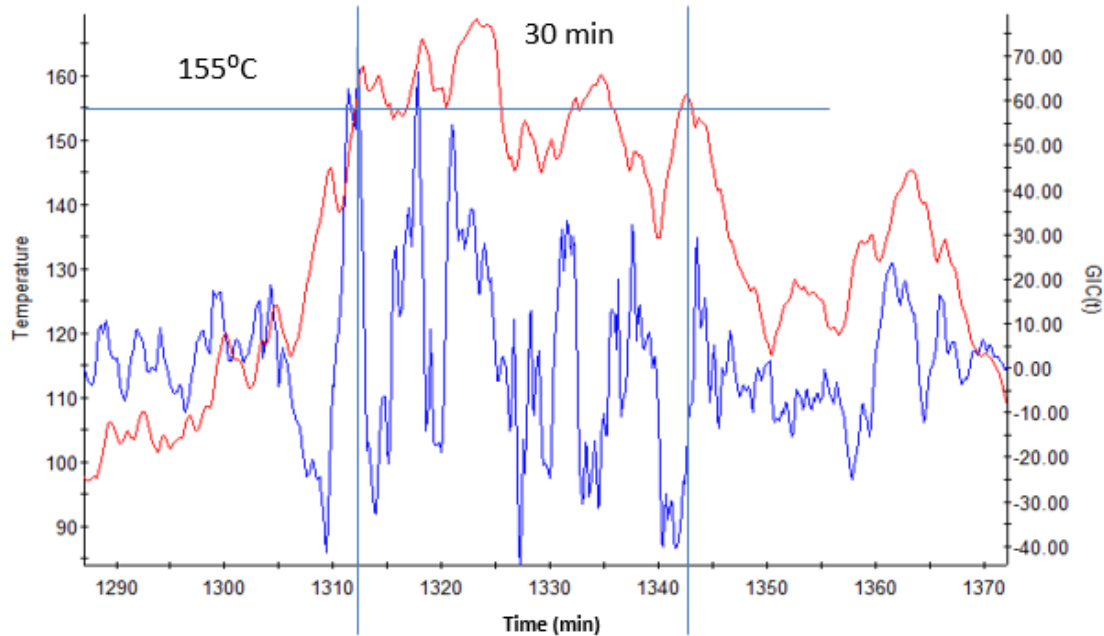
Consequently, with the most conservative thermal models known at this point in time, the peak metallic hot spot temperature obtained with the benchmark GMD event waveform assuming an effective GIC magnitude of 75 A per phase will result in a peak temperature between 160°C and 172°C when the bulk oil temperature is 80°C (full load bulk oil temperature). The upper boundary of 172°C remains well below the metallic hot spot 200°C threshold for short-time emergency loading suggested in IEEE Std C57.91-2011 — Guide for Loading Mineral-Oil-Immersed Transformers and Step-Voltage Regulators [5].

The selection of the 75 A per phase screening threshold is based on the following considerations:

- A thermal assessment, which uses the most conservative thermal models known to date, indicates that a GIC of 75A will not result in peak metallic hot spot temperatures above 172°C. Transformer thermal assessments should not be required by Reliability Standards when results will fall well below IEEE Std C57.91-2011 limits.

- Applicable entities may choose to carry out a thermal assessment when the effective GIC is below 75 A per phase to take into account the age or condition of specific transformers where IEEE Std C57.91- 2011 limits could be assumed to be lower than 200°C. Refer to IEEE Standard C57.163-2015 Guide for Establishing Power Transformer Capability while under Geomagnetic Disturbances for additional information [6].
- The models used to determine the 75 A per phase screening threshold are known to be conservative at higher values of effective GIC, especially the SVC coupling transformer model in [2].
- Thermal models in peer-reviewed technical literature, especially those calculated models without experimental validation, are less conservative than the models used to determine the screening threshold. Therefore, a technically-justified thermal assessment for effective GIC below 75 A per phase using the benchmark GMD event geomagnetic field waveform will always result in a “pass” on the basis of the state of the knowledge at this point in time.
- Based on simulations, the 75 A per phase screening threshold will result in a maximum instantaneous peak hot spot temperature of 172°C. However, IEEE Std C57.91-2011 limits assume short term emergency operation (typically 30 minutes). As illustrated in Figure 2, simulations of the 75 A per phase screening threshold result in 30-minute duration hot spot temperatures of about 155°C. The threshold provides an added measure of conservatism in not taking into account the duration of hot spot temperatures.
- The models used in the determination of the threshold are conservative but technically justified.
- Winding hot spots are not the limiting factor in terms of hot spots due to half-cycle saturation, therefore the screening criterion is focused on metallic part hot spots only.

The 75 A per phase screening threshold was determined using single-phase transformers, but is being applied as a screening criterion for all types of transformer construction. While it is known that some transformer types such as three-limb, three-phase transformers are intrinsically less susceptible to GIC, it is not known by how much, on the basis of experimentally-supported models.



**Figure 2: Metallic hot spot temperatures calculated using the benchmark GMD event**

Red: metallic hot spot temperature

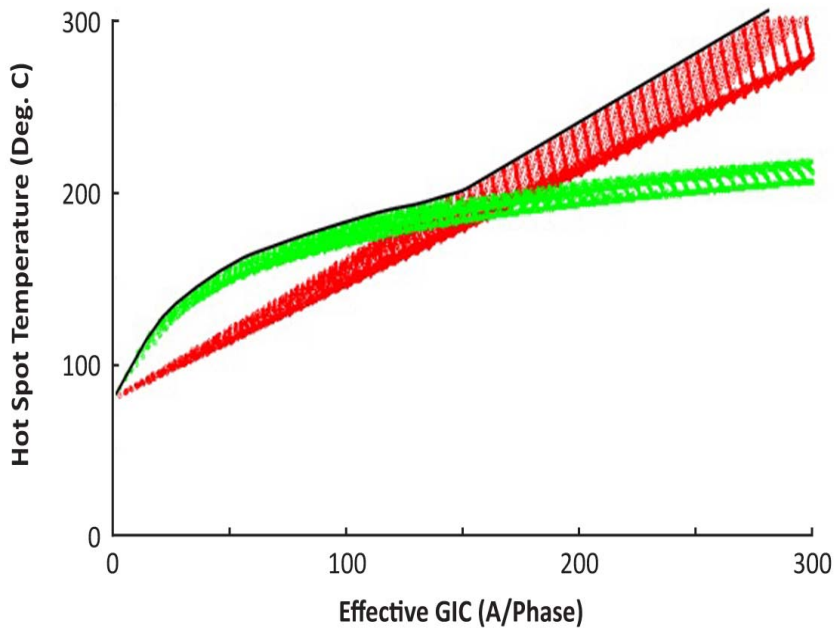
Blue: GIC(t) that produces the maximum hot spot temperature with peak GIC(t) scaled to 75 A/phase

## Justification for the Supplemental Screening Criterion

As in the case for the benchmark GMD event discussed above, applicable entities are required to carry out thermal assessments on their BES power transformers when the effective GIC values are above a screening threshold. GIC(t) for supplemental thermal assessments is calculated using the supplemental GMD event geomagnetic field time series or waveform.

Using the supplemental GMD event waveform, a thermal analysis was completed for the two transformers that were limiting for the benchmark waveform. The results are shown in Figure 3. Peak metallic hot spot temperatures for the supplemental GMD event will lie below the envelope shown by the black line trace in Figure 3. Because the supplemental waveform has a sharper peak, the peak metallic hot spot temperatures are slightly lower than those associated with the benchmark waveform. Applying the most conservative thermal models known at this point in time, the peak metallic hot spot temperature obtained with the supplemental GMD event waveform assuming an effective GIC magnitude of 85 A per phase will result in a peak temperature of 172°C when the bulk oil temperature is 80°C (full load bulk oil temperature).<sup>3</sup> Thus, 85 A per phase is the screening level for the supplemental waveform.

<sup>3</sup> — The temperature 172°C was selected as the screening criteria for the benchmark waveform as described in the preceding section.



**Figure 3: Metallic hot spot temperatures calculated using the supplemental GMD event**  
Red: SVC coupling transformer model [2] Green: Autotransformer model [4]

## Appendix I - Transformer Thermal Models Used in the Development of the Screening Criteria

The envelope used for thermal screening (Figure 1) is derived from two thermal models. The first is based on laboratory measurements carried out on 500/16.5 kV 400 MVA single-phase Static Var Compensator (SVC) coupling transformer [2]. Temperature measurements were carried out at relatively small values of GIC (see Figure I-1). The asymptotic thermal response for this model is the linear extrapolation of the known measurement values. Although the near-linear behavior of the asymptotic thermal response is consistent with the measurements made on a Fingrid 400 kV 400 MVA five-leg core-type fully-wound transformer [3] (see Figures I-2 and I-3), the extrapolation from low values of GIC is very conservative, but reasonable for screening purposes.

The second transformer model is based on a combination of measurements and modeling for a 400 kV 400 MVA single-phase core-type autotransformer [4] (see Figures I-4 and I-5). The asymptotic thermal behavior of this transformer shows a “down-turn” at high values of GIC as the tie plate increasingly saturates but relatively high temperatures for lower values of GIC. The hot spot temperatures are higher than for the two other models for GIC less than 125 A per phase.

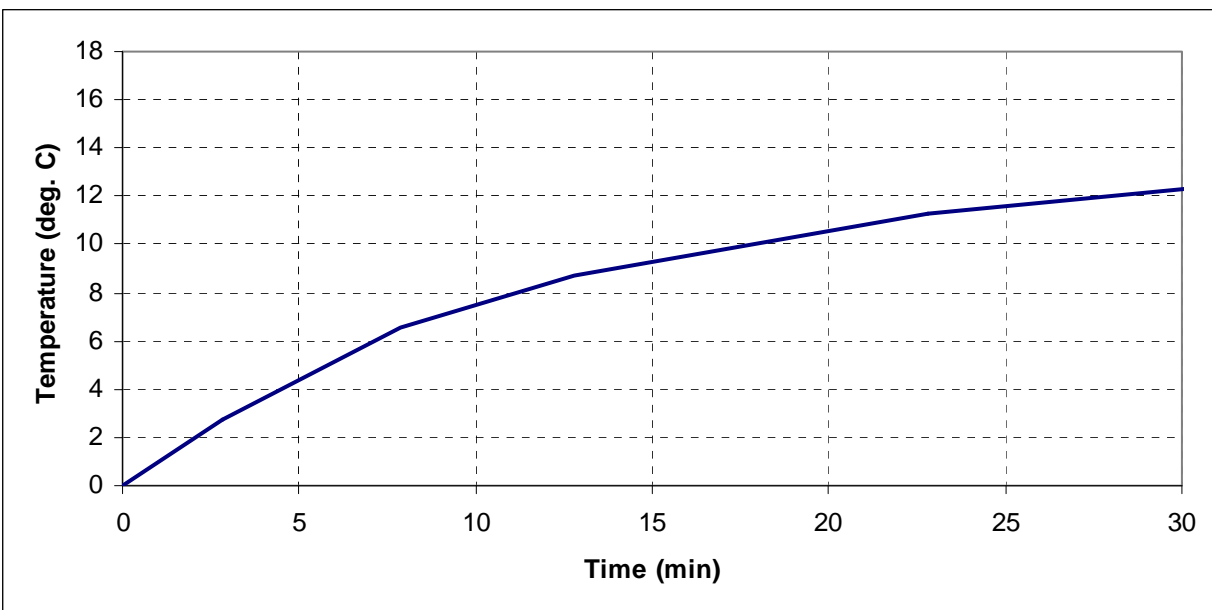


Figure I-1: Thermal step response of the tie plate of a 500 kV 400 MVA single-phase SVC coupling transformer to a 5 A per phase dc step

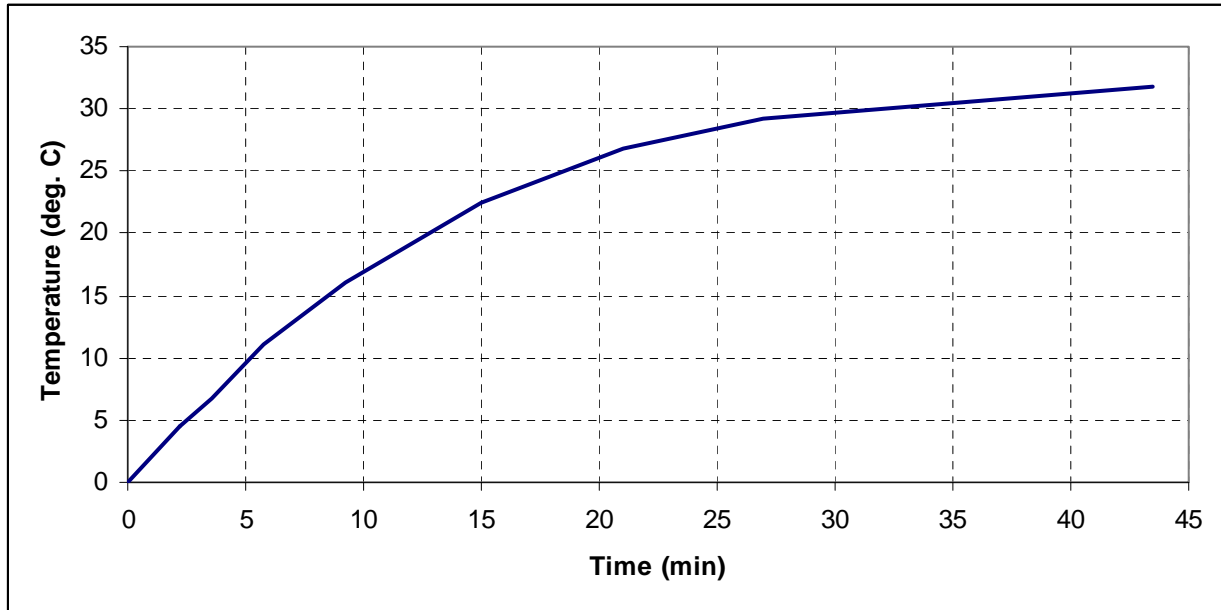


Figure I-2: Step thermal response of the top yoke clamp of a 400 kV 400 MVA five-leg core-type fully-wound transformer to a 16.67 A per phase dc step

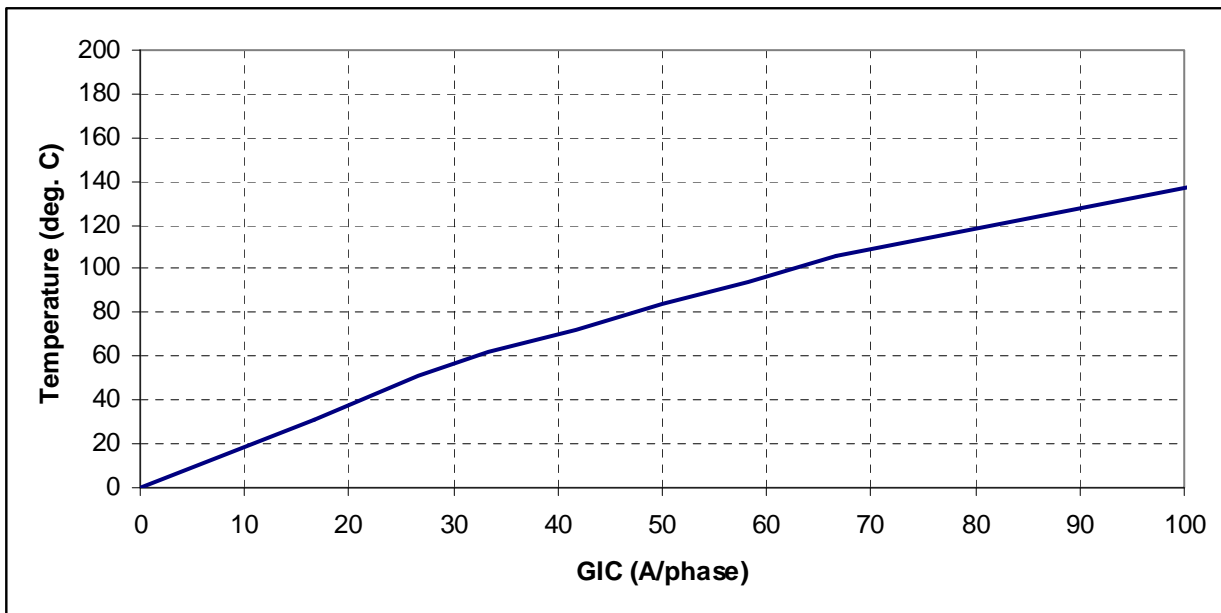


Figure I-3: Asymptotic thermal response of the top yoke clamp of a 400 kV 400 MVA five-leg core-type fully-wound transformer

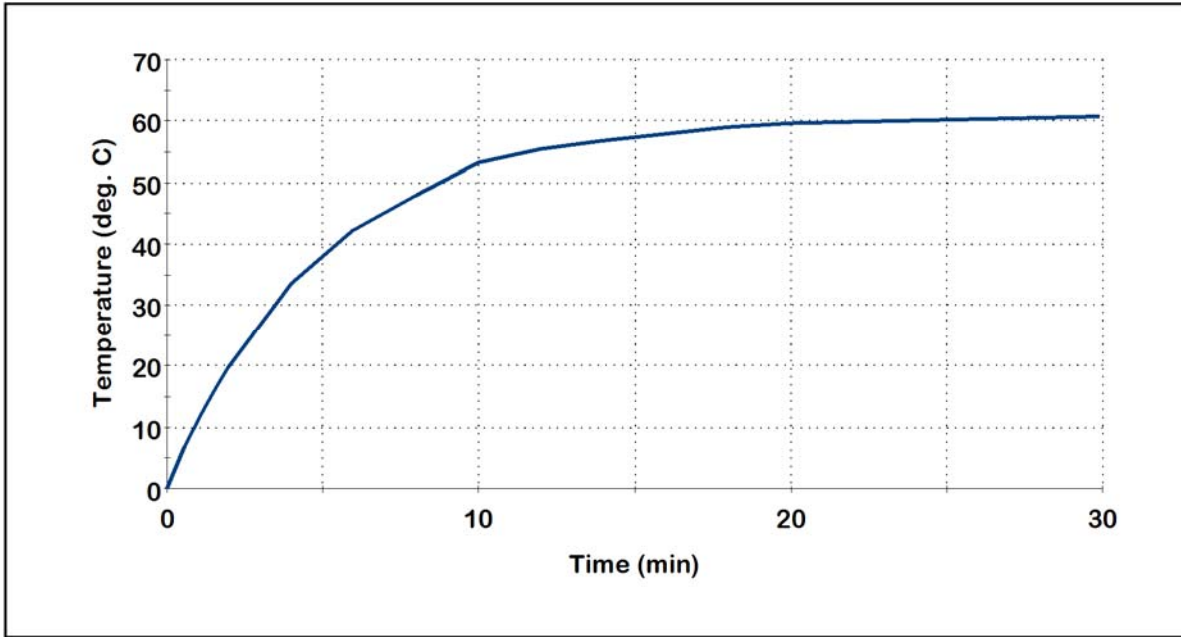


Figure I-4: Step thermal response of the tie plate of a 400 kV 400 MVA single-phase core-type autotransformer to a 10 A per phase dc step

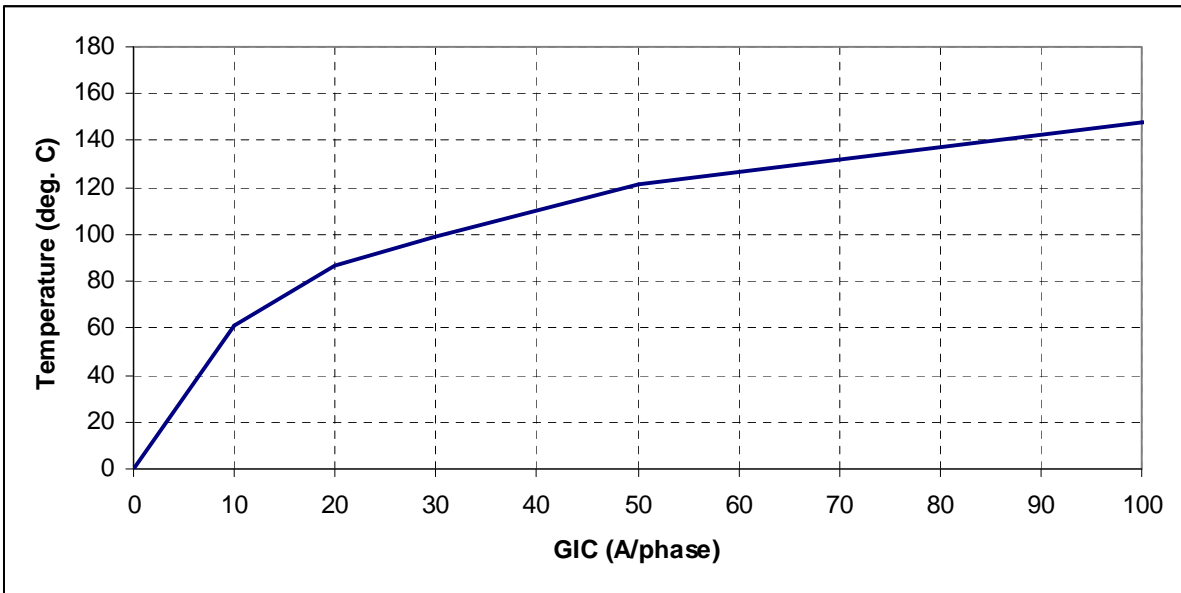


Figure I-5: Asymptotic thermal response of the tie plate of a 400 kV 400 MVA single-phase core-type autotransformer

The envelope in Figure 1 can be used as a conservative thermal assessment for effective GIC values of associated with the benchmark waveform [and reference earth model](#) (see Table 1).

Effective GIC (A/phase)	Metallic hot spot Temperature (°C)	Effective GIC (A/phase)	Metallic hot spot Temperature (°C)
0	80	100	182
10	107	110	186
20	128	120	190
30	139	130	193
40	148	140	204
50	157	150	213
60	169	160	221
70	170	170	230
75	172	180	234
80	175	190	241
90	179	200	247

For instance, if effective GIC is 130 A per phase and oil temperature is assumed to be 80°C, peak hot spot temperature is 193°C. This value is below the 200°C IEEE Std C57.91-2011 threshold for short time emergency loading and this transformer will have passed the thermal assessment. If the full heat run oil temperature is 67°C at maximum ambient temperature, then 150 A per phase of effective GIC translates into a peak hot spot temperature of 200°C and the transformer will have passed. If the limit is lowered to 180°C to account for the condition of the transformer, then this would be an indication to “sharpen the pencil” and perform a detailed assessment. Some methods are described in Reference [1].

The temperature envelope in Figure 1 corresponds to the values of effective GIC that result in the highest temperature for the benchmark GMD event. Different values of effective GIC could result in lower temperatures using the same model. For instance, the difference in upper and lower bounds of peak temperatures for the SVC coupling transformer model for 150 A per phase is approximately 30°C. In this case, GIC(t) should be generated to calculate the peak temperatures for the actual configuration of the transformer within the system as described in Reference [1]. Alternatively, a more precise thermal assessment could be carried out with a thermal model that more closely represents the thermal behavior of the transformer under consideration.

Similar to the discussion above, the envelope in Figure 3 can be used as a conservative thermal assessment for effective GIC values of associated with the supplemental waveform (see Table 2). ~~Because the~~The supplemental waveform has a sharper peak; therefore, the peak metallic hot spot temperatures associated with the supplemental waveform for the same peak current are slightly lower than those associated with



the benchmark waveform. In other words, for the same peak current value, the duration is relatively shorter with the supplemental waveform, and shorter duration means lower temperature. However, higher peak currents will occur with the supplemental benchmark, therefore, higher peak hot spot temperatures will occur. Comparing Tables 1 and 2 shows the magnitude of this difference.

Effective GIC (A/phase)	Metallic hot spot Temperature (°C)	Effective GIC(A/phase)	Metallic hot spot Temperature (°C)
0	80	120	188
10	107	130	191
20	124	140	194
30	137	150	198
40	147	160	203
50	156	170	209
60	161	180	214
70	162	190	229
75	165	200	237
80	169	220	248
85	172	230	253
90	177	250	276
100	181	275	298
110	185	300	316

## References

- [1] Transformer Thermal Impact Assessment white paper. Developed by the Project 2013-03 (Geomagnetic Disturbance) standard drafting team. October 2017. Available at: <http://www.nerc.com/pa/stand/Pages/TPL0071RI.aspx>
- [2] Marti, L.; Rezaei-Zare, A.; and Narang, A. "Simulation of Transformer Hotspot Heating due to Geomagnetically Induced Currents." *IEEE Transactions on Power Delivery*, vol.28, no.1, pp.320-327, Jan. 2013.
- [3] Lahtinen, ~~Matti Jarmo~~ M. and Elovaara, J. "GIC occurrences and GIC test for 400 kV system transformer". *IEEE Transactions on Power Delivery*, Vol. 17, No. 2. April 2002.
- [4] ~~J. Raith, S.J. and Ausserhofer, S.~~ "GIC Strength verification of Power Transformers in a High Voltage Laboratory", GIC Workshop, Cape Town, April 2014
- [5] "IEEE Guide for Loading Mineral-Oil-Immersed Transformers and Step-Voltage Regulators." IEEE Std C57.91-2011 (Revision of IEEE Std C57.91-1995).
- [6] "IEEE Guide for Establishing Power Transformer Capability while under Geomagnetic Disturbances." IEEE Std C57.163-2015.

# Transformer Thermal Impact Assessment White Paper

## TPL-007-2 – Transmission System Planned Performance for Geomagnetic Disturbance Events

### Background

Proposed TPL-007-2 includes requirements for entities to perform two types of geomagnetic disturbance (GMD) Vulnerability Assessments to evaluate the potential impacts of GMD events on the Bulk Electric System (BES):

- The benchmark GMD Vulnerability Assessment is based on the benchmark GMD event associated with TPL-007-1 which was approved by the Federal Energy Regulatory Commission (FERC) in Order No. 830 in September 2016. The benchmark GMD event is derived from spatially-averaged geoelectric field values to address potential wide-area effects that could be caused by a severe 1-in-100 year GMD event.<sup>1</sup>
- The supplemental GMD Vulnerability Assessment, based on the supplemental GMD event, is used by entities to evaluate localized peaks in geomagnetic field during a severe GMD event that "could potentially affect the reliable operation of the Bulk-Power System."<sup>2</sup> Localized enhancements of geomagnetic field can result in geoelectric field values above the spatially-averaged benchmark in a local area.

The standard requires transformer thermal impact assessments to be performed on BES power transformers with high side, wye-grounded windings with terminal voltage greater than 200 kV. Large power transformers connected to the extra-high voltage (EHV) transmission system can experience both winding and structural hot spot heating as a result of GMD events. TPL-007-2 requires owners of such BES transformers to conduct thermal analyses to determine if the BES transformers will be able to withstand the thermal transient effects associated with the GMD events. BES transformers must undergo a thermal impact assessment if the maximum effective geomagnetically-induced current (GIC) in the transformer is equal to or greater than:<sup>3</sup>

- 75 A per phase for the benchmark GMD event
- 85 A per phase for the supplemental GMD event

This white paper discusses methods that can be employed to conduct transformer thermal impact assessments, including example calculations. The first version of the white paper was developed by the Project 2013-03 GMD Standards Drafting Team (SDT) for TPL-007-1 and was endorsed by the Electric

<sup>1</sup> See *Benchmark Geomagnetic Disturbance Event Description* white paper, May 12, 2016. Filed by NERC in RM15-11 on June 28, 2016.

<sup>2</sup> See Order No. 830 P. 47. On September 22, 2016, FERC directed NERC to develop modifications to the benchmark GMD event, included in TPL-007-1, such that assessments would not be based solely on spatially averaged data. The characteristics of a GMD event for this assessment are in the Supplemental GMD Event Description white paper.

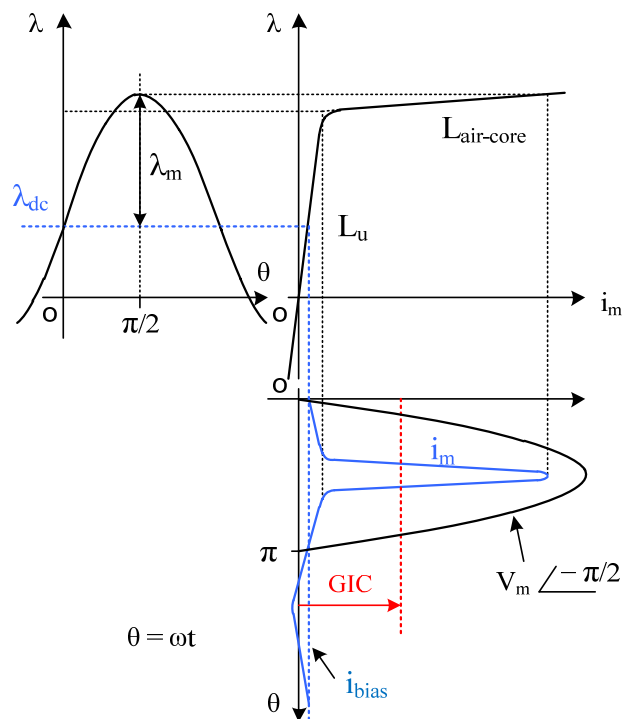
<sup>3</sup> See *Screening Criterion for Transformer Thermal Impact Assessment* for technical justification.

Reliability Organization (ERO) as implementation guidance in October 2016. The SDT has updated the white paper to include the supplemental GMD event that is added in TPL-007-2 to address directives in FERC Order No. 830.

The primary impact of GMDs on large power transformers is a result of the quasi-dc current that flows through wye-grounded transformer windings. This GIC results in an offset of the ac sinusoidal flux resulting in asymmetric or half-cycle saturation (see Figure 1).

Half-cycle saturation results in a number of known effects:

- Hot spot heating of transformer windings due to harmonics and stray flux;
- Hot spot heating of non-current carrying transformer metallic members due to stray flux;
- Harmonics;
- Increase in reactive power absorption; and
- Increase in vibration and noise level.



**Figure 1: Mapping Magnetization Current to Flux through Core Excitation Characteristics**

This paper focuses on hot spot heating of transformer windings and non-current-carrying metallic parts. Effects such as the generation of harmonics, increase in reactive power absorption, vibration, and noise are not within the scope of this document.

## Technical Considerations

The effects of half-cycle saturation on high-voltage (HV) and EHV transformers, namely localized “hot spot” heating, are relatively well understood, but are difficult to quantify. A transformer GMD impact assessment must consider GIC amplitude, duration, and transformer physical characteristics such as design and condition (e.g., age, gas content, and moisture in the oil). A single threshold value of GIC cannot be justified as a “pass or fail” screening criterion where “fail” means that the transformer will suffer damage. A single threshold value of GIC only makes sense in the context where “fail” means that a more detailed study is required. Such a threshold would have to be technically justifiable and sufficiently low to be considered a conservative value of GIC.

The following considerations should be taken into account when assessing the thermal susceptibility of a transformer to half-cycle saturation:

- In the absence of manufacturer specific information, use the temperature limits for safe transformer operation such as those suggested in the IEEE Std C57.91-2011 (IEEE Guide for Loading Mineral-oil-immersed Transformers and Step-voltage Regulators) for hot spot heating during short-term emergency operation [1]. This standard does not suggest that exceeding these limits will result in transformer failure, but rather that it will result in additional aging of cellulose in the paper-oil insulation and the potential for the generation of gas bubbles in the bulk oil. Thus, from the point of view of evaluating possible transformer damage due to increased hot spot heating, these thresholds can be considered conservative for a transformer in good operational condition.
- The worst case temperature rise for winding and metallic part (e.g., tie plate) heating should be estimated taking into consideration the construction characteristics of the transformer as they pertain to dc flux offset in the core (e.g., single-phase, shell, 5 and 3-leg three-phase construction).
- Bulk oil temperature due to ambient temperature and transformer loading must be added to the incremental temperature rise caused by hot spot heating. For planning purposes, maximum ambient and loading temperature should be used unless there is a technically justified reason to do otherwise.
- The time series or “waveform” of the reference GMD event in terms of peak amplitude, duration, and frequency of the geoelectric field has an important effect on hot spot heating. Winding and metallic part hot spot heating have different thermal time constants, and their temperature rise will be different if the GIC currents are sustained for 2, 10, or 30 minutes for a given GIC peak amplitude.
- The “effective” GIC in autotransformers (reflecting the different GIC ampere-turns in the common and the series windings) must be used in the assessment. The effective current  $I_{dc,eq}$  in an autotransformer is defined by [2].

$$I_{dc,eq} = I_H + (I_N/3 - I_H) \times V_X/V_H \quad (1)$$

where

$I_H$  is the dc current in the high voltage winding;

$I_N$  is the neutral dc current;

$V_H$  is the root mean square (rms) rated voltage at HV terminals; and

$V_X$  is the rms rated voltage at the LV terminals.

## Transformer Thermal Impact Assessment Process

A simplified thermal assessment may be based on the appropriate tables from the “Screening Criterion for Transformer Thermal Impact Assessment” white paper [3].<sup>4</sup> Each table below provides the peak metallic hot spot temperatures that can be reached for the given GMD event using conservative thermal models. To use each table, one must select the bulk oil temperature and the threshold for metallic hot spot heating, for instance, from reference [1] after allowing for possible de-rating due to transformer condition. If the effective GIC results in higher than threshold temperatures, then the use of a detailed thermal assessment as described below should be carried out.<sup>5</sup>

<b>Table 1: Upper Bound of Peak Metallic Hot Spot Temperatures Calculated Using the Benchmark GMD Event</b>			
<b>Effective GIC (A/phase)</b>	<b>Metallic hot spot Temperature (°C)</b>	<b>Effective GIC (A/phase)</b>	<b>Metallic hot spot Temperature (°C)</b>
0	80	100	182
10	107	110	186
20	128	120	190
30	139	130	193
40	148	140	204
50	157	150	213
60	169	160	221
70	170	170	230
75	172	180	234
80	175	190	241
90	179	200	247

<sup>4</sup> Table 1 in the *Screening Criterion for Transformer Thermal Impact Assessment* white paper provides upper bound temperatures for the benchmark GMD event. Table 2 in the *Screening Criterion for Transformer Thermal Impact Assessment* white paper provides upper bound temperatures for the supplemental GMD event.

<sup>5</sup> Effective GIC in the table is the peak GIC(t) for the GMD event being assessed. Peak GIC(t) is not steady-state GIC.

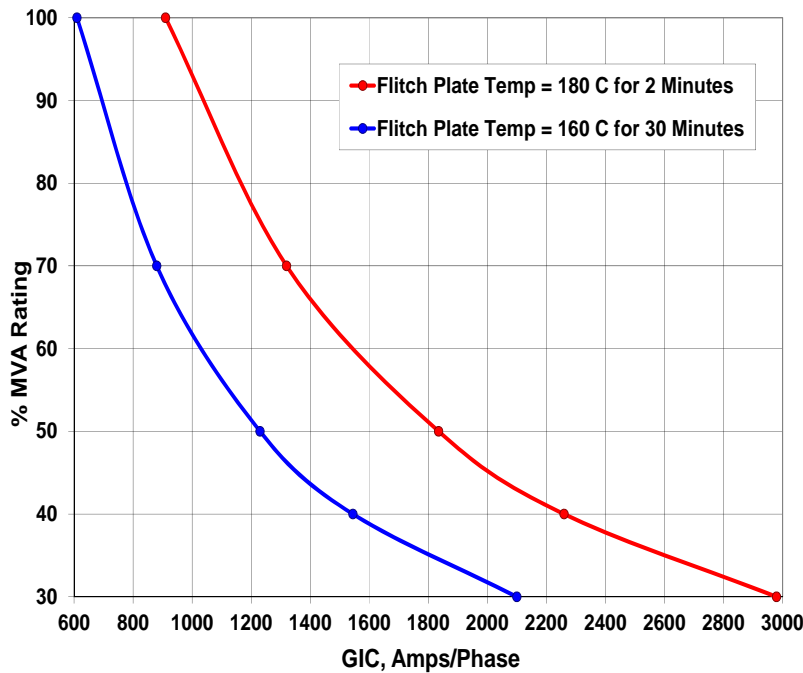
**Table 2: Upper Bound of Peak Metallic Hot Spot Temperatures Calculated Using the Supplemental GMD Event**

Effective GIC (A/phase)	Metallic hot spot Temperature (°C)	Effective GIC (A/phase)	Metallic hot spot Temperature (°C)
0	80	120	188
10	107	130	191
20	124	140	194
30	137	150	198
40	147	160	203
50	156	170	209
60	161	180	214
70	162	190	229
75	165	200	237
80	169	220	248
85	172	230	253
90	177	250	276
100	181	275	298
110	185	300	316

Two different ways to carry out a detailed thermal impact assessment are discussed below. In addition, other approaches and models approved by international standard-setting organizations such as the Institute of Electrical and Electronic Engineers (IEEE) or International Council on Large Electric Systems (CIGRE) may also provide technically justified methods for performing thermal assessments.<sup>6</sup> All thermal assessment methods should be demonstrably equivalent to assessments that use the GMD events associated with TPL-007-2.

1. Transformer manufacturer GIC capability curves. These curves relate permissible peak GIC (obtained by the user from a steady-state GIC calculation) and loading, for a specific transformer. An example of manufacturer capability curves is provided in Figure 2. Presentation details vary between manufacturers, and limited information is available regarding the assumptions used to generate these curves, in particular, the assumed waveshape or duration of the effective GIC. Some manufacturers assume that the waveform of the GIC in the transformer windings is a square pulse of 2, 10, or 30 minutes in duration. In the case of the transformer capability curve shown in Figure 2, a square pulse of 900 A/phase with a duration of 2 minutes would cause the Flitch plate hot spot to reach a temperature of 180°C at full load [5]. While GIC capability curves are relatively simple to use, an amount of engineering judgment is necessary to ascertain which portion of a GIC waveform is equivalent to, for example, a 2 minute pulse. Also, manufacturers generally maintain that in the absence of transformer standards defining thermal duty due to GIC, such capability curves must be developed for every transformer design and vintage.

<sup>6</sup> For example, C57.163-2015 – IEEE Guide for Establishing Power Transformer Capability while under Geomagnetic Disturbances. [4]

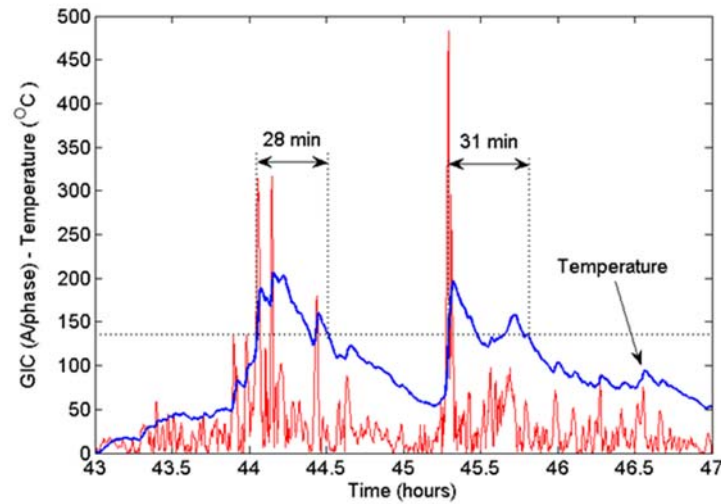


**Figure 2: Sample GIC Manufacturer Capability Curve of a Large Single-Phase Transformer Design using the Flitch Plate Temperature Criteria [5]**

2. Thermal response simulation.<sup>7</sup> The input to this type of simulation is the time series or waveform of effective GIC flowing through a transformer (taking into account the actual configuration of the system), and the result of the simulation is the hot spot temperature (winding or metallic part) time sequence for a given transformer. An example of GIC input and hotspot temperature time series values from [6] are shown in Figure 3. The hot spot thermal transfer functions can be obtained from measurements or calculations provided by transformer manufacturers. Conservative default values can be used (e.g., those provided in [6]) when specific data are not available. Hot spot temperature thresholds shown in Figure 3 are consistent with IEEE Std C57.91-2011 emergency loading hot spot limits. Emergency loading time limit is usually 30 minutes.

<sup>7</sup> Technical details of this methodology can be found in [6].





**Figure 3: Sample Tie Plate Temperature Calculation**

Blue trace is incremental temperature and red trace is the magnitude of the GIC/phase [6]

It is important to reiterate that the characteristics of the time sequence or “waveform” are very important in the assessment of the thermal impact of GIC on transformers. Transformer hot spot heating is not instantaneous. The thermal time constants of transformer windings and metallic parts are typically on the order of minutes to tens of minutes; therefore, hot spot temperatures are heavily dependent on GIC history and rise time, amplitude and duration of GIC in the transformer windings, bulk oil temperature due to loading, ambient temperature and cooling mode.

### Calculation of the GIC Waveform for a Transformer

The following procedure can be used to generate time series GIC data (i.e., GIC(t)) using a software program capable of computing GIC in the steady-state. The steps are as follows:

1. Calculate contribution of GIC due to eastward and northward geoelectric fields for the transformer under consideration; and
2. Scale the GIC contribution according to the reference geoelectric field time series to produce the GIC time series for the transformer under consideration.

Most available GIC-capable software packages can calculate GIC in steady-state in a transformer assuming a uniform eastward geoelectric field of 1 V/km ( $GIC_E$ ) while the northward geoelectric field is zero. Similarly,  $GIC_N$  can be obtained for a uniform northward geoelectric field of 1 V/km while the eastward geoelectric field is zero.  $GIC_E$  and  $GIC_N$  are the normalized GIC contributions for the transformer under consideration.

If the earth conductivity is assumed to be uniform (or laterally uniform) in the transmission system of interest, then the transformer GIC (in A/phase) for any value of  $E_E(t)$  and  $E_N(t)$  can be calculated using (2) [2].

$$GIC(t) = |E(t)| \times \{GIC_E \times \sin(\varphi(t)) + GIC_N \times \cos(\varphi(t))\} \quad (2)$$

where,

$$|E(t)| = \sqrt{E_E^2(t) + E_N^2(t)} \quad (3)$$

$$\varphi(t) = \tan^{-1} \left( \frac{E_E(t)}{E_N(t)} \right) \quad (4)$$

$$GIC(t) = E_E(t) \times GIC_E + E_N(t) \times GIC_N \quad (5)$$

$GIC_N$  is the effective GIC due to a northward geoelectric field of 1 V/km, and  $GIC_E$  is the effective GIC due to an eastward geoelectric field of 1 V/km. The units for  $GIC_N$  and  $GIC_E$  are A/phase per V/km).

The geoelectric field time series  $E_N(t)$  and  $E_E(t)$  is obtained, for instance, from the reference geomagnetic field time series (from [7] and/or [8]) after the appropriate geomagnetic latitude scaling factor  $\alpha$  is applied.<sup>8</sup> The reference geoelectric field time series is calculated using the reference earth model. When using this geoelectric field time series where a different earth model is applicable, it should be scaled with the appropriate conductivity scaling factor  $\beta$ .<sup>9</sup> Alternatively, the geoelectric field can be calculated from the reference geomagnetic field time series after the appropriate geomagnetic latitude scaling factor  $\alpha$  is applied and the appropriate earth model is used. In such case, the conductivity scaling factor  $\beta$  is not applied because it is already accounted for by the use of the appropriate earth model.

Applying (5) to each point in  $E_N(t)$  and  $E_E(t)$  results in  $GIC(t)$ .

### GIC(t) Calculation Example

Let us assume that from the steady-state solution, the effective GIC in this transformer is  $GIC_E = -20$  A/phase if  $E_N=0$ ,  $E_E=1$  V/km and  $GIC_N = 26$  A/phase if  $E_N=1$  V/km,  $E_E=0$ . Let us also assume the geomagnetic field time

<sup>8</sup> The geomagnetic factor  $\alpha$  is described in [2] and is used to scale the geomagnetic field according to geomagnetic latitude. The lower the geomagnetic latitude (closer to the equator), the lower the amplitude of the geomagnetic field.

<sup>9</sup> The conductivity scaling factor  $\beta$  is described in [2], and is used to scale the geoelectric field according to the conductivity of different physiographic regions. Lower conductivity results in higher  $\beta$  scaling factors.

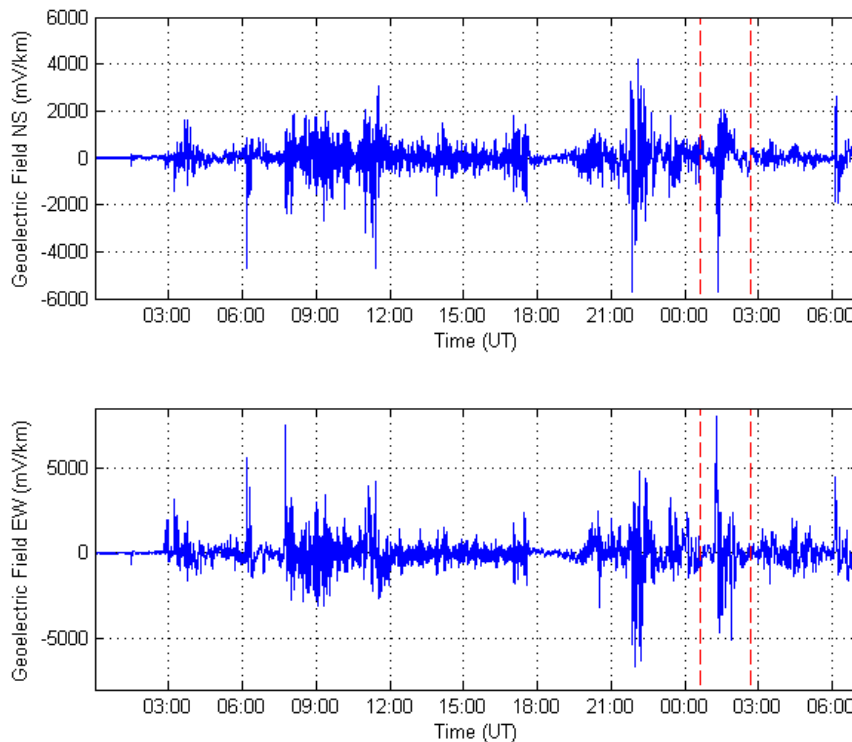
series corresponds to a geomagnetic latitude where  $\alpha = 1$  and that the earth conductivity corresponds to the reference earth model in [7]. The resulting geoelectric field time series is shown in Figure 4. Therefore:

$$GIC(t) = E_E(t) \times GIC_E + E_N(t) \times GIC_N \text{ (A/Phase)} \quad (6)$$

$$GIC(t) = -E_E(t) \times 20 + E_N(t) \times 26 \text{ (A/Phase)} \quad (7)$$

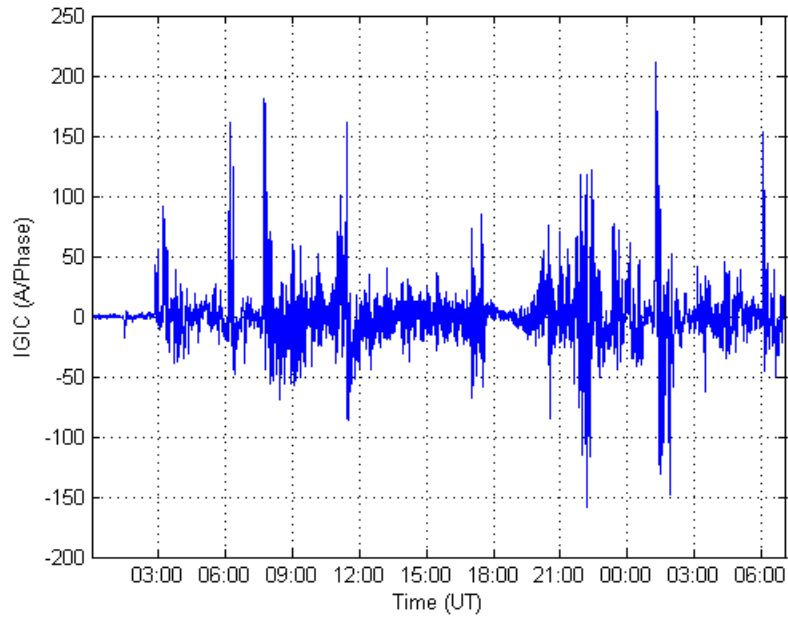
The resulting GIC waveform  $GIC(t)$  is shown in Figures 5 and 6 and can subsequently be used for thermal analysis.

It should be emphasized that even for the same reference event, the  $GIC(t)$  waveform in every transformer will be different, depending on the location within the system and the number and orientation of the circuits connecting to the transformer station. Assuming a single generic  $GIC(t)$  waveform to test all transformers is incorrect.

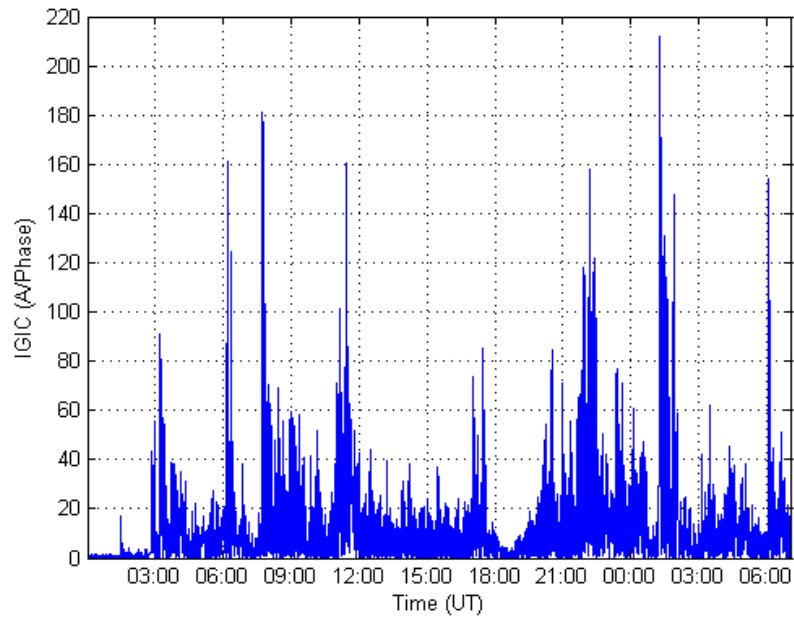


**Figure 4: Calculated Geoelectric Field  $E_N(t)$  and  $E_E(t)$  Assuming  $\alpha=1$  and  $\beta=1$  (Reference Earth Model)**

Zoom area for subsequent graphs is highlighted  
Dashed lines approximately show the close-up area for subsequent Figures



**Figure 5: Calculated GIC(t) Assuming  $\alpha=1$  and  $\beta=1$  Reference Earth Model**



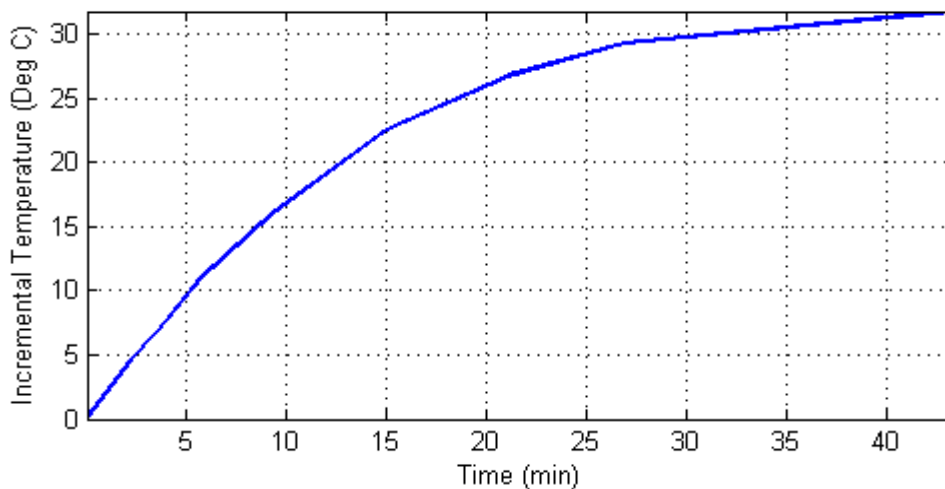
**Figure 6: Calculated Magnitude of GIC(t) Assuming  $\alpha=1$  and  $\beta=1$  Reference Earth Model**

### Transformer Thermal Assessment Examples

There are two basic ways to carry out a transformer thermal analysis once the GIC time series  $GIC(t)$  is known for a given transformer: 1) calculating the thermal response as a function of time; and 2) using manufacturer’s capability curves.

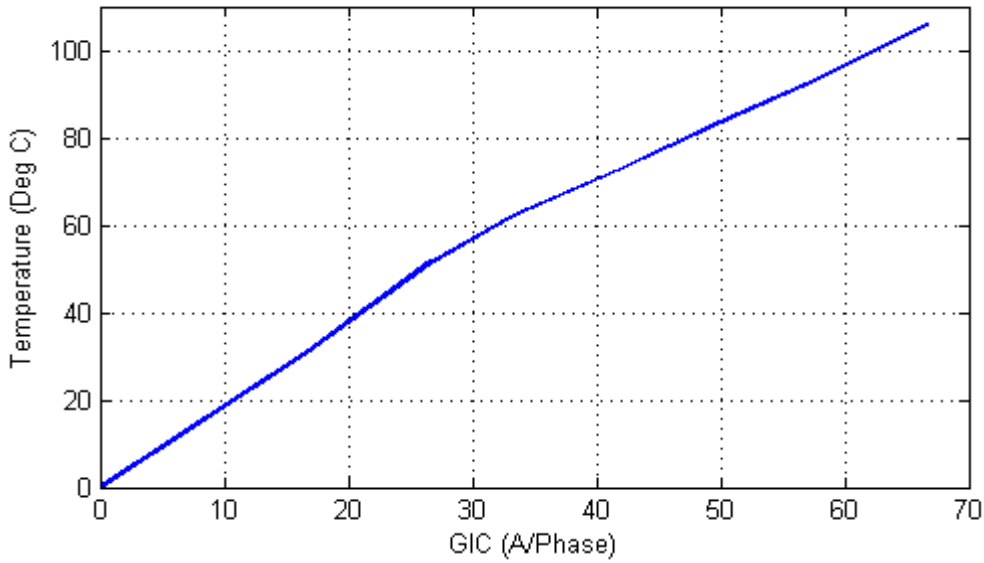
#### *Example 1: Calculating thermal response as a function of time using a thermal response tool*

The thermal step response of the transformer can be obtained for both winding and metallic part hot spots from: 1) measurements; 2) manufacturer’s calculations; or 3) generic published values. Figure 7 shows the measured metallic hot spot thermal response to a dc step of 16.67 A/phase of the top yoke clamp from [9] that will be used in this example. Figure 8 shows the measured incremental temperature rise (asymptotic response) of the same hot spot to long duration GIC steps.<sup>10</sup>



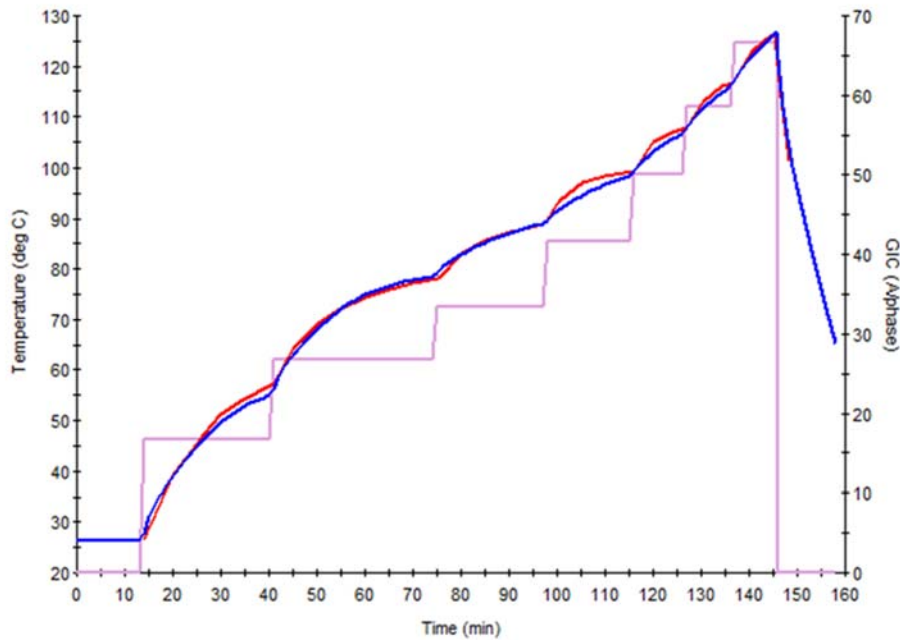
**Figure 7: Thermal Step Response to a 16.67 Amperes per Phase dc Step**  
 Metallic hot spot heating

<sup>10</sup> Heating of bulk oil due to the hot spot temperature increase is not included in the asymptotic response because the time constant of bulk oil heating is at least an order of magnitude larger than the time constants of hot spot heating.



**Figure 8: Asymptotic Thermal Step Response**  
 Metallic hot spot heating

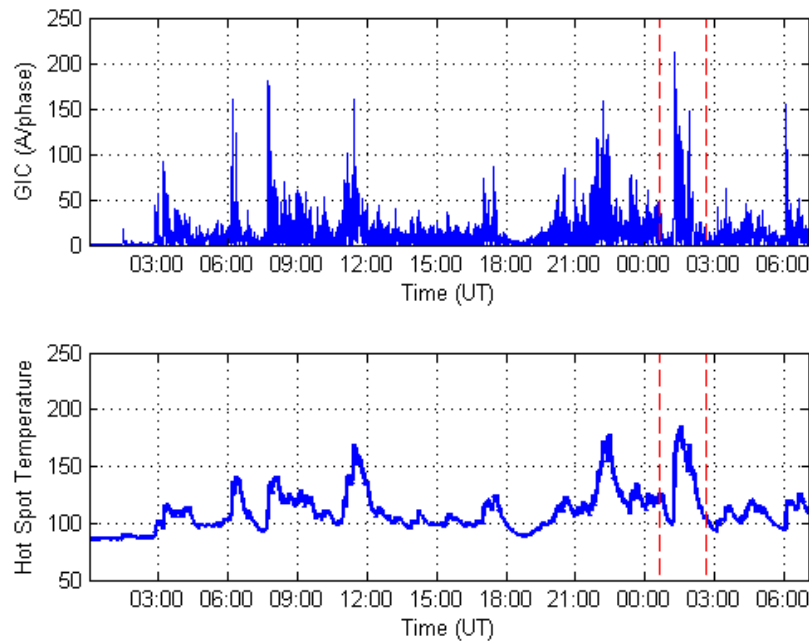
The step response in Figure 7 was obtained from the first GIC step of the tests carried out in [6]. The asymptotic thermal response in Figure 8 was obtained from the final or near-final temperature values after each subsequent GIC step. Figure 9 shows a comparison between measured temperatures and the calculated temperatures using the thermal response model used in the rest of this discussion.



**Figure 9: Comparison of measured temperatures (red) and simulation results (blue)**  
 Injected current is represented by magenta

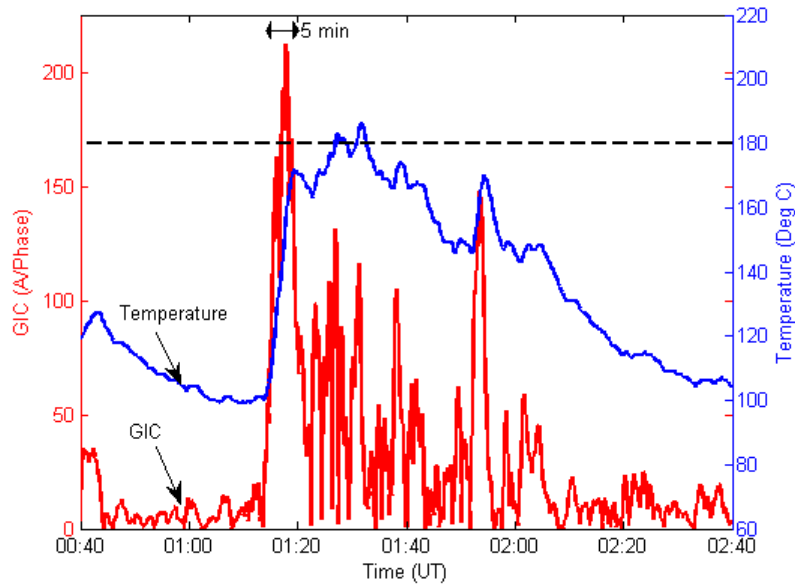
To obtain the thermal response of the transformer to a GIC waveform such as the one in Figure 6, a thermal response model is required. To create a thermal response model, the measured or manufacturer-calculated transformer thermal step responses (winding and metallic part) for various GIC levels are required. The GIC(t) time series or waveform is then applied to the thermal model to obtain the incremental temperature rise as a function of time  $\theta(t)$  for the GIC(t) waveform. The total temperature is calculated by adding the oil temperature, for example, at full load.

Figure 10 illustrates the calculated GIC(t) and the corresponding metallic hot spot temperature time series  $\theta(t)$ . Figure 11 illustrates a close-up view of the peak transformer temperatures calculated in this example.



**Figure 10: Magnitude of GIC(t) and Metallic Hot Spot Temperature  $\theta(t)$  Assuming Full Load Oil Temperature of 85.3°C (40°C ambient)**

Dashed lines approximately show the close-up area for subsequent figures



**Figure 11: Close-up of Metallic Hot Spot Temperature Assuming a Full Load**  
 Blue trace is  $\theta(t)$  Red trace is  $GIC(t)$

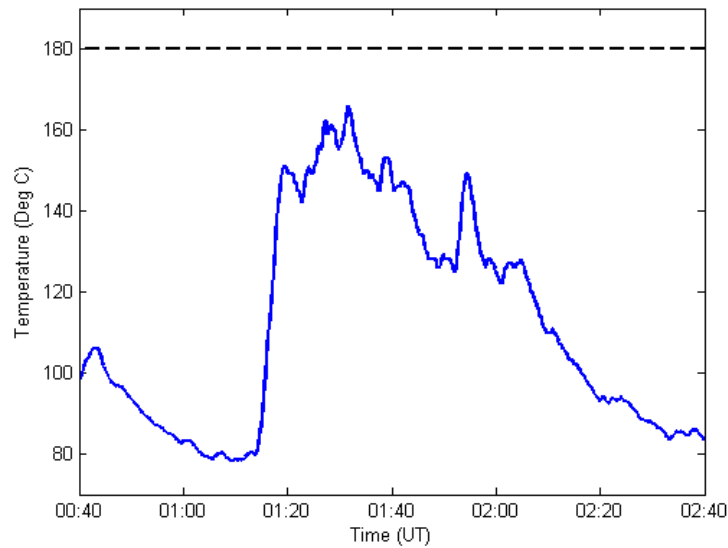
In this example, the IEEE Std C57.91-2011 emergency loading hot spot threshold of 200°C for metallic hot spot heating is not exceeded. Peak temperature is 186°C. The IEEE standard is silent as to whether the temperature can be higher than 200°C for less than 30 minutes. Manufacturers can provide guidance on individual transformer capability.

It is not unusual to use a lower temperature threshold of 180°C to account for calculation and data margins, as well as transformer age and condition. Figure 11 shows that 180°C will be exceeded for 5 minutes.

At 75% loading, the initial temperature is 64.6°C rather than 85.3°C, and the hot spot temperature peak is 165°C, well below the 180°C threshold (see Figure 12).

If a conservative threshold of 160°C were used to account for the age and condition of the transformer, then the full load limits would be exceeded for approximately 22 minutes.

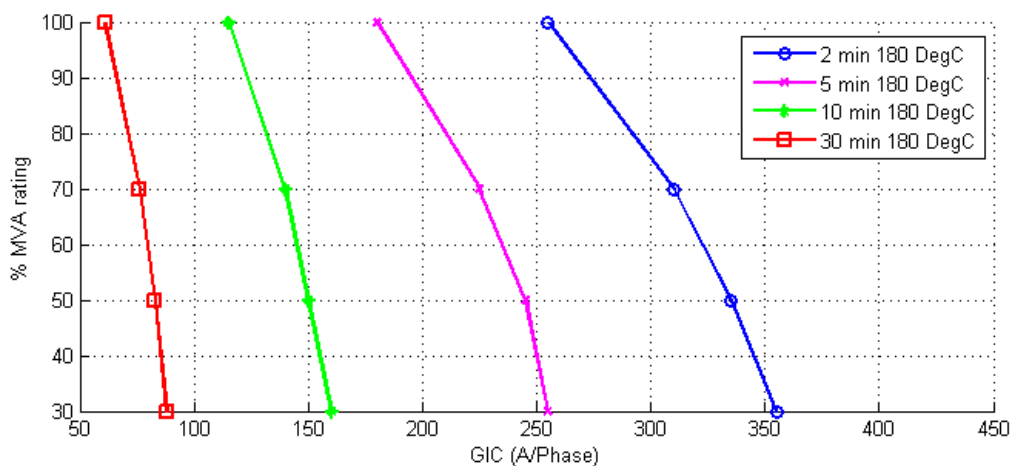




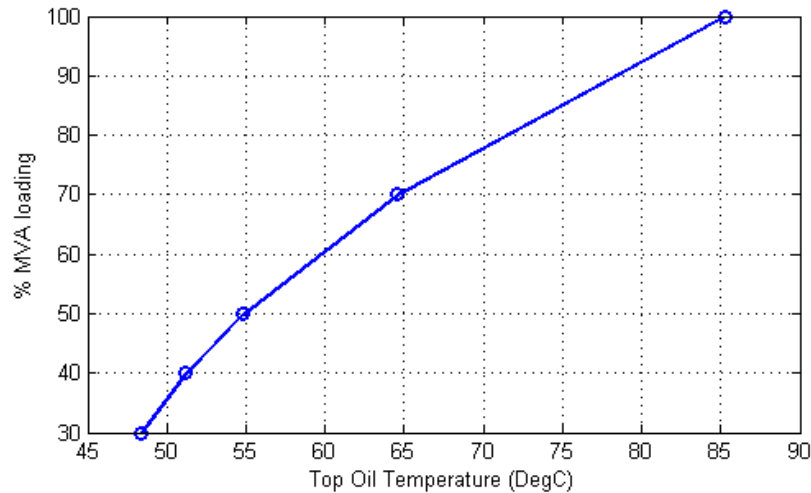
**Figure 12: Close-up of Metallic Hot Spot Temperature Assuming a 75% Load**  
Oil temperature of 64.5°C

**Example 2: Using a Manufacturer’s Capability Curves**

The capability curves used in this example are shown in Figure 13. To maintain consistency with the previous example, these particular capability curves have been reconstructed from the thermal step response shown in Figures 7 and 8, and the simplified loading curve shown in Figure 14 (calculated using formulas from IEEE Std C57.91-2011).



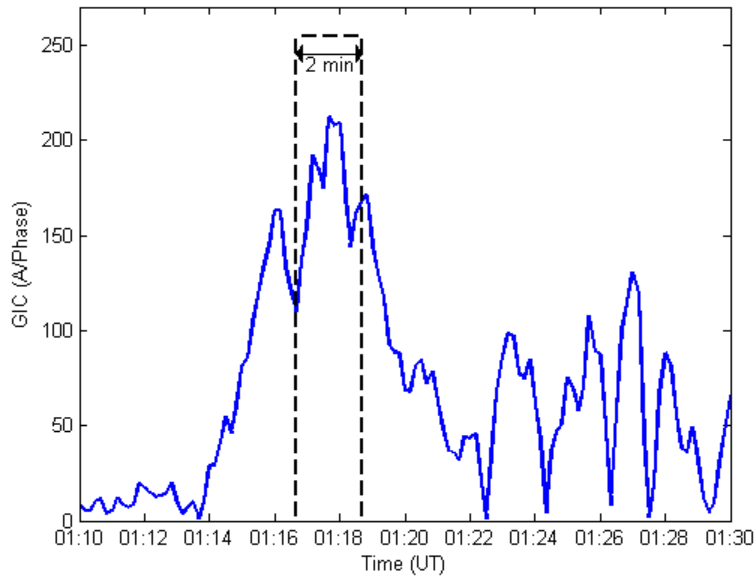
**Figure 13: Capability Curve of a Transformer Based on the Thermal Response Shown in Figures 8 and 9**



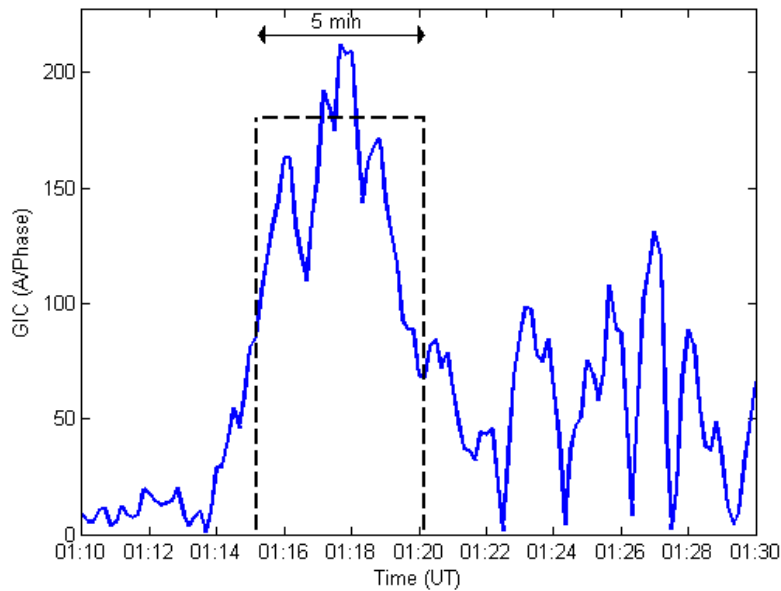
**Figure 14: Simplified Loading Curve Assuming 40°C Ambient Temperature**

The basic notion behind the use of capability curves is to compare the calculated GIC in a transformer with the limits at different GIC pulse widths. A narrow GIC pulse has a higher limit than a longer duration or wider one. If the calculated GIC and assumed pulse width falls below the appropriate pulse width curve, then the transformer is within its capability.

To use these curves, it is necessary to estimate an equivalent square pulse that matches the waveform of GIC(t), generally at a GIC(t) peak. Figure 15 shows a close-up of the GIC near its highest peak superimposed to a 255 Amperes per phase, 2 minute pulse at 100% loading from Figure 13. Since a narrow 2-minute pulse is not representative of GIC(t) in this case, a 5 minute pulse with an amplitude of 180 A/phase at 100% loading has been superimposed on Figure 16. It should be noted that a 255 A/phase, 2 minute pulse is equivalent to a 180 A/phase 5 minute pulse from the point of view of transformer capability. Deciding what GIC pulse is equivalent to the portion of GIC(t) under consideration is a matter of engineering judgment.



**Figure 15: Close-up of GIC(t) and a 2 minute 255 A/phase GIC pulse at full load**



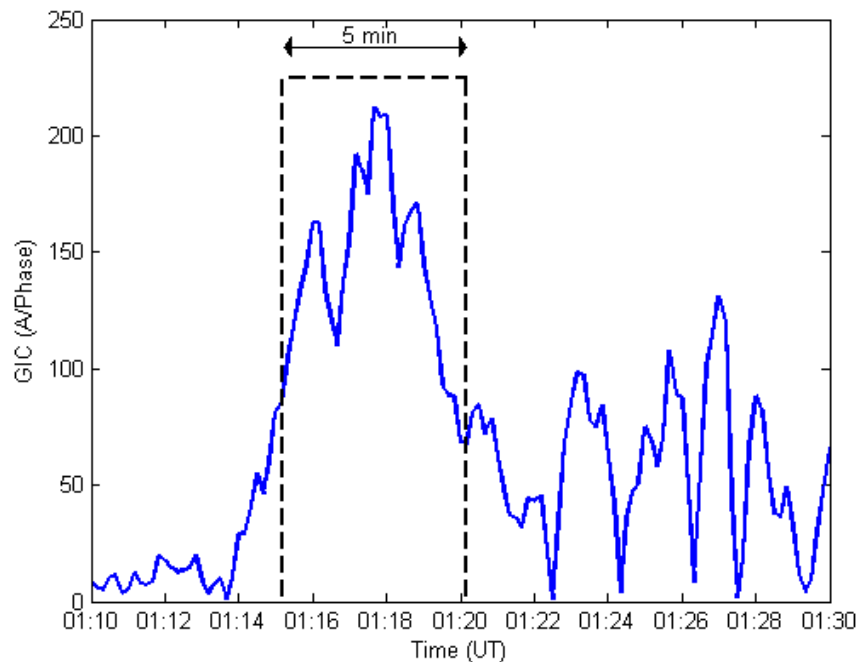
**Figure 16: Close-up of GIC(t) and a Five Minute 180 A/phase GIC Pulse at Full Load**

When using a capability curve, it should be understood that the curve is derived assuming that there is no hot spot heating due to prior GIC at the time the GIC pulse occurs (only an initial temperature due to loading). Therefore, in addition to estimating the equivalent pulse that matches GIC(t), prior metallic hot

spot heating must be accounted for. From these considerations, it is unclear whether the capability curves would be exceeded at full load with a 180°C threshold in this example.

At 70% loading, the two and five minute pulses from Figure 13 would have amplitudes of 310 and 225 A/phase, respectively. The 5 minute pulse is illustrated in Figure 17. In this case, judgment is also required to assess if the GIC(t) is within the capability curve for 70% loading. In general, capability curves are easier to use when GIC(t) is substantially above, or clearly below the GIC thresholds for a given pulse duration.

If a conservative threshold of 160°C were used to account for the age and condition of the transformer, then a new set of capability curves would be required.



**Figure 17: Close-up of GIC(t) and a 5 Minute 225 A/phase GIC Pulse Assuming 70% Load**

## References

- [1] "IEEE Guide for Loading Mineral-Oil-Immersed Transformers and Step-Voltage Regulators." IEEE Std C57.91-2011 (Revision of IEEE Std C57.91-1995). March 7, 2012.
- [2] "Application Guide: Computing Geomagnetically-Induced Current in the Bulk-Power System," NERC. December 2013. Available at: [http://www.nerc.com/comm/PC/Geomagnetic%20Disturbance%20Task%20Force%20GMDTF%202013/GIC%20Application%20Guide%202013\\_approved.pdf](http://www.nerc.com/comm/PC/Geomagnetic%20Disturbance%20Task%20Force%20GMDTF%202013/GIC%20Application%20Guide%202013_approved.pdf).
- [3] "Screening Criterion for Transformer Thermal Impact Assessment." Developed by the Project 2013-03 (Geomagnetic Disturbance) standard drafting team. October 2017. Available at: <http://www.nerc.com/pa/Stand/Pages/Project-2013-03-Geomagnetic-Disturbance-Mitigation.aspx>.
- [4] "IEEE Guide for Establishing Power Transformer Capability while under Geomagnetic Disturbances." IEEE Std C57.163-2015. October 26, 2015.
- [5] Girgis, R.; Vedante, K. "Methodology for evaluating the impact of GIC and GIC capability of power transformer designs." IEEE Power and Energy Society 2013 General Meeting Proceedings. Vancouver, Canada.
- [6] Marti, L.; Rezaei-Zare, A.; and Narang, A. "Simulation of Transformer Hotspot Heating due to Geomagnetically Induced Currents." IEEE Transactions on Power Delivery, Vol.28, No.1. pp 320-327. January 2013.
- [7] "Benchmark Geomagnetic Disturbance Event Description" white paper. Developed by the Project 2013-03 (Geomagnetic Disturbance) standard drafting team. May 2016. Available at: <http://www.nerc.com/pa/Stand/Pages/Project-2013-03-Geomagnetic-Disturbance-Mitigation.aspx>.
- [8] "Supplemental Geomagnetic Disturbance Event Description" white paper. Developed by the Project 2013-03 (Geomagnetic Disturbance) standard drafting team. October 2017. Available at: <http://www.nerc.com/pa/Stand/Pages/Project-2013-03-Geomagnetic-Disturbance-Mitigation.aspx>.
- [9] Lahtinen, M; and Elovaara, J. "GIC occurrences and GIC test for 400 kV system transformer." IEEE Transactions on Power Delivery, Vol. 17, No. 2. pp 555-561. April 2002.

# Transformer Thermal Impact Assessment White Paper

## TPL-007-2— Transmission System Planned Performance for Geomagnetic Disturbance Events

### Background

Proposed TPL-007-2 includes requirements for entities to perform two types of [geomagnetic disturbance \(GMD\)](#) Vulnerability Assessments to evaluate the potential impacts of GMD events on the Bulk Electric System (BES):

- The benchmark GMD Vulnerability Assessment is based on the benchmark GMD event associated with TPL-007-1 which was approved by the Federal Energy Regulatory Commission (FERC) in Order No. 830 in September 2016. The benchmark GMD event is derived from spatially-averaged geoelectric field values to address potential wide-area effects that could be caused by a severe 1-in-100 year GMD event.<sup>1</sup>
- The supplemental GMD Vulnerability Assessment, based on the supplemental GMD event, is used by entities to evaluate localized peaks in geomagnetic field during a severe GMD event that "could potentially affect the reliable operation of the Bulk-Power System."<sup>2</sup> Localized enhancements of geomagnetic field can result in geoelectric field values above the spatially-averaged benchmark in a local area.

The standard requires transformer thermal impact assessments to be performed on BES power transformers with high side, wye-grounded windings with terminal voltage greater than 200 kV. Large power transformers connected to the [extra-high voltage \(EHV\)](#) transmission system can experience both winding and structural hot spot heating as a result of GMD events. TPL-007-2 requires owners of such BES transformers to conduct thermal analyses to determine if the BES transformers will be able to withstand the thermal transient effects associated with the GMD events. BES [Transformers](#) must undergo a thermal impact assessment if the maximum effective geomagnetically-induced current (GIC) in the transformer is equal to or greater than:<sup>3</sup>

- 75 A per phase for the benchmark GMD event
- 85 A per phase for the supplemental GMD event

This white paper discusses methods that can be employed to conduct transformer thermal impact assessments, including example calculations. The first version of the white paper was developed by the Project 2013-03 GMD Standards Drafting Team (SDT) for TPL-007-1 and was endorsed by the Electric

<sup>1</sup> See *Benchmark Geomagnetic Disturbance Event Description* white paper, May 12, 2016. Filed by NERC in RM15-11 on June 28, 2016.

<sup>2</sup> See Order No. 830 P. 47. On September 22, 2016, FERC directed NERC to develop modifications to the benchmark GMD event, included in TPL-007-1, such that assessments would not be based solely on spatially averaged data. The characteristics of a GMD event for this assessment are in the Supplemental GMD Event Description white paper.

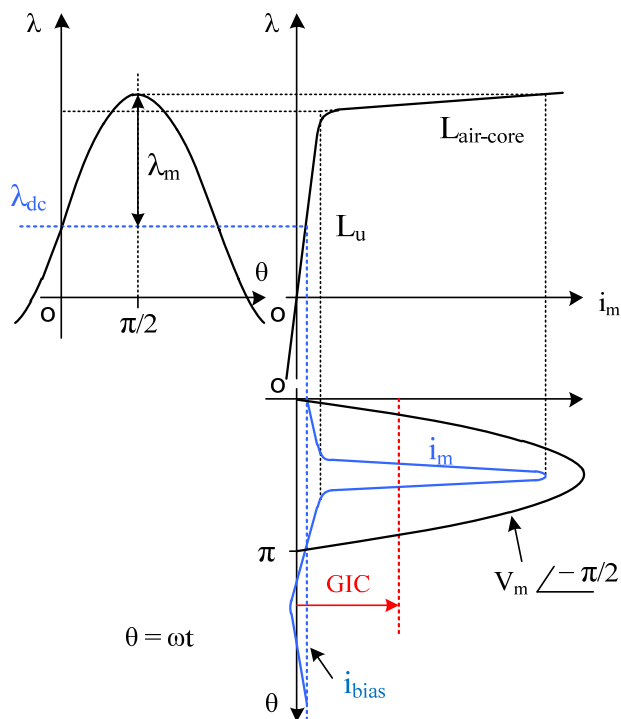
<sup>3</sup> See *Screening Criterion for Transformer Thermal Impact Assessment* for technical justification.

Reliability Organization (ERO) as implementation guidance in October 2016. The SDT has updated the white paper to include the supplemental GMD event that is added in TPL-007-2 to address directives in FERC Order No. 830.

The primary impact of GMDs on large power transformers is a result of the quasi-dc current that flows through wye-grounded transformer windings. This [geomagnetically induced current \(GIC\)](#) results in an offset of the ac sinusoidal flux resulting in asymmetric or half-cycle saturation (see Figure 1).

Half-cycle saturation results in a number of known effects:

- Hot spot heating of transformer windings due to harmonics and stray flux;
- Hot spot heating of non-current carrying transformer metallic members due to stray flux;
- Harmonics;
- Increase in reactive power absorption; and
- Increase in vibration and noise level.



**Figure 1: Mapping Magnetization Current to Flux through Core Excitation Characteristics**

This paper focuses on hot spot heating of transformer windings and non-current-carrying metallic parts. Effects such as the generation of harmonics, increase in reactive power absorption, vibration, and noise are not within the scope of this document.

## Technical Considerations

The effects of half-cycle saturation on [high-voltage \(HV\)](#) and EHV transformers, namely localized “hot spot” heating, are relatively well understood, but are difficult to quantify. A transformer GMD impact assessment must consider GIC amplitude, duration, and transformer physical characteristics such as design and condition (e.g., age, gas content, and moisture in the oil). A single threshold value of GIC cannot be justified as a “pass or fail” screening criterion where “fail” means that the transformer will suffer damage. A single threshold value of GIC only makes sense in the context where “fail” means that a more detailed study is required. Such a threshold would have to be technically justifiable and sufficiently low to be considered a conservative value of GIC.

The following considerations should be taken into account when assessing the thermal susceptibility of a transformer to half-cycle saturation:

- In the absence of manufacturer specific information, use the temperature limits for safe transformer operation such as those suggested in the IEEE Std C57.91-2011 (IEEE Guide for Loading Mineral-oil-immersed Transformers and Step-voltage Regulators) for hot spot heating during short-term emergency operation [1]. This standard does not suggest that exceeding these limits will result in transformer failure, but rather that it will result in additional aging of cellulose in the paper-oil insulation and the potential for the generation of gas bubbles in the bulk oil. Thus, from the point of view of evaluating possible transformer damage due to increased hot spot heating, these thresholds can be considered conservative for a transformer in good operational condition.
- The worst case temperature rise for winding and metallic part (e.g., tie plate) heating should be estimated taking into consideration the construction characteristics of the transformer as they pertain to dc flux offset in the core (e.g., single-phase, shell, 5 and 3-leg three-phase construction).
- Bulk oil temperature due to ambient temperature and transformer loading must be added to the incremental temperature rise caused by hot spot heating. For planning purposes, maximum ambient and loading temperature should be used unless there is a technically justified reason to do otherwise.
- The time series or “waveform” of the reference GMD event in terms of peak amplitude, duration, and frequency of the geoelectric field has an important effect on hot spot heating. Winding and metallic part hot spot heating have different thermal time constants, and their temperature rise will be different if the GIC currents are sustained for 2, 10, or 30 minutes for a given GIC peak amplitude.
- The “effective” GIC in autotransformers (reflecting the different GIC ampere-turns in the common and the series windings) must be used in the assessment. The effective current  $I_{dc,eq}$  in an autotransformer is defined by [2].



$$I_{dc,eq} = I_H + (I_N/3 - I_H) \times V_X/V_H \quad (1)$$

where

$I_H$  is the dc current in the high voltage winding;

$I_N$  is the neutral dc current;

$V_H$  is the [root mean square \(rms\)](#) rated voltage at HV terminals; [and](#)

$V_X$  is the rms rated voltage at the LV terminals.

## Transformer Thermal Impact Assessment Process

A simplified thermal assessment may be based on the appropriate tables from the “Screening Criterion for Transformer Thermal Impact Assessment” white paper [3].<sup>4</sup> Each table below provides the peak metallic hot spot temperatures that can be reached for the given GMD event using conservative thermal models. To use each table, one must select the bulk oil temperature and the threshold for metallic hot spot heating, for instance, from reference [1] after allowing for possible de-rating due to transformer condition. If the effective GIC results in higher than threshold temperatures, then the use of a detailed thermal assessment as described below should be carried out.<sup>5</sup>

Table 1: Upper Bound of Peak Metallic Hot Spot Temperatures Calculated Using the Benchmark GMD Event			
Effective GIC (A/phase)	Metallic hot spot Temperature (°C)	Effective GIC (A/phase)	Metallic hot spot Temperature (°C)
0	80	100	182
10	107	110	186
20	128	120	190
30	139	130	193
40	148	140	204
50	157	150	213
60	169	160	221
70	170	170	230
75	172	180	234
80	175	190	241
90	179	200	247

<sup>4</sup> Table 1 in the *Screening Criterion for Transformer Thermal Impact Assessment* white paper provides upper bound temperatures for the benchmark GMD event. Table 2 in the *Screening Criterion for Transformer Thermal Impact Assessment* white paper provides upper bound temperatures for the supplemental GMD event.

<sup>5</sup> Effective GIC in the table is the peak GIC(t) for the GMD event being assessed. Peak GIC(t) is not steady-state GIC.

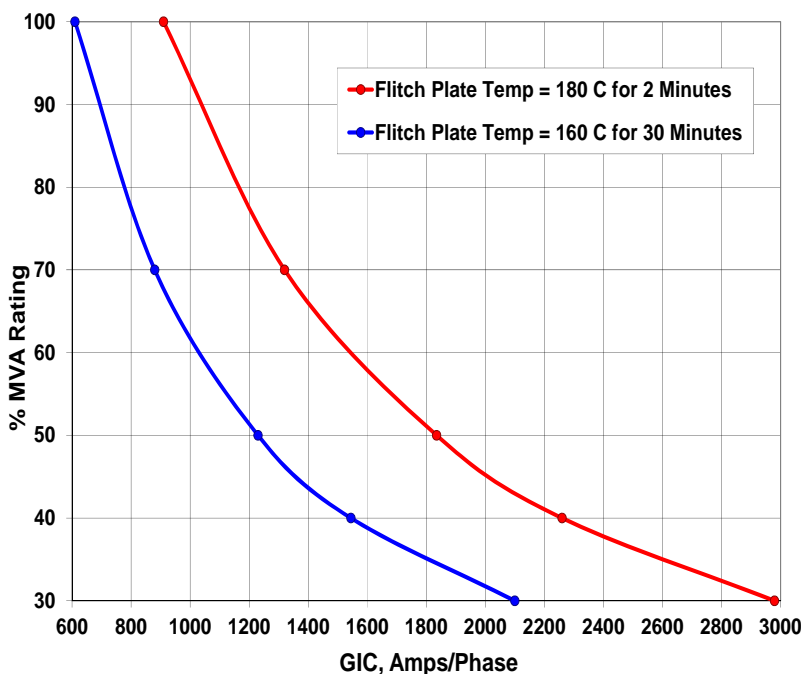
**Table 2: Upper Bound of Peak Metallic Hot Spot Temperatures Calculated Using the Supplemental GMD Event**

Effective GIC (A/phase)	Metallic hot spot Temperature (°C)	Effective GIC (A/phase)	Metallic hot spot Temperature (°C)
0	80	120	188
10	107	130	191
20	124	140	194
30	137	150	198
40	147	160	203
50	156	170	209
60	161	180	214
70	162	190	229
75	165	200	237
80	169	220	248
85	172	230	253
90	177	250	276
100	181	275	298
110	185	300	316

Two different ways to carry out a detailed thermal impact assessment are discussed below. In addition, other approaches and models approved by international standard-setting organizations such as the Institute of Electrical and Electronic Engineers (IEEE) or International Council on Large Electric Systems (CIGRE) may also provide technically justified methods for performing thermal assessments.<sup>6</sup> All thermal assessment methods should be demonstrably equivalent to assessments that use the GMD events associated with TPL-007-2.

1. Transformer manufacturer GIC capability curves. These curves relate permissible peak GIC (obtained by the user from a steady-state GIC calculation) and loading, for a specific transformer. An example of manufacturer capability curves is provided in Figure 2. Presentation details vary between manufacturers, and limited information is available regarding the assumptions used to generate these curves, in particular, the assumed waveshape or duration of the effective GIC. Some manufacturers assume that the waveform of the GIC in the transformer windings is a square pulse of 2, 10, or 30 minutes in duration. In the case of the transformer capability curve shown in Figure 2, a square pulse of 900 A/phase with a duration of 2 minutes would cause the Flitch plate hot spot to reach a temperature of 180°C at full load [5]. While GIC capability curves are relatively simple to use, an amount of engineering judgment is necessary to ascertain which portion of a GIC waveform is equivalent to, for example, a 2 minute pulse. Also, manufacturers generally maintain that in the absence of transformer standards defining thermal duty due to GIC, such capability curves must be developed for every transformer design and vintage.

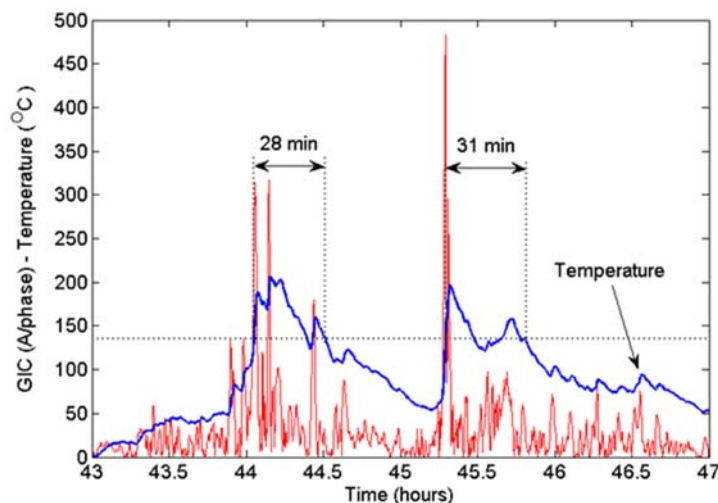
<sup>6</sup> For example, C57.163-2015 – IEEE Guide for Establishing Power Transformer Capability while under Geomagnetic Disturbances. [4]



**Figure 2: Sample GIC Manufacturer Capability Curve of a Large Single-Phase Transformer Design using the Flitch Plate Temperature Criteria [5]**

2. Thermal response simulation.<sup>7</sup> The input to this type of simulation is the time series or waveform of effective GIC flowing through a transformer (taking into account the actual configuration of the system), and the result of the simulation is the hot spot temperature (winding or metallic part) time sequence for a given transformer. An example of GIC input and hotspot temperature time series values from [6] are shown in Figure 3. The hot spot thermal transfer functions can be obtained from measurements or calculations provided by transformer manufacturers. Conservative default values can be used (e.g., those provided in [6]) when specific data are not available. Hot spot temperature thresholds shown in Figure 3 are consistent with IEEE Std C57.91-2011 emergency loading hot spot limits. Emergency loading time limit is usually 30 minutes.

<sup>7</sup> Technical details of this methodology can be found in [6].



**Figure 3: Sample Tie Plate Temperature Calculation**

Blue trace is incremental temperature and red trace is the magnitude of the GIC/phase [6]

It is important to reiterate that the characteristics of the time sequence or “waveform” are very important in the assessment of the thermal impact of GIC on transformers. Transformer hot spot heating is not instantaneous. The thermal time constants of transformer windings and metallic parts are typically on the order of minutes to tens of minutes; therefore, hot spot temperatures are heavily dependent on GIC history and rise time, amplitude and duration of GIC in the transformer windings, bulk oil temperature due to loading, ambient temperature and cooling mode.

### Calculation of the GIC Waveform for a Transformer

The following procedure can be used to generate time series GIC data (i.e., GIC(t)) using a software program capable of computing GIC in the steady-state. The steps are as follows:

1. Calculate contribution of GIC due to eastward and northward geoelectric fields for the transformer under consideration; [and](#)
2. Scale the GIC contribution according to the reference geoelectric field time series to produce the GIC time series for the transformer under consideration.

Most available GIC-capable software packages can calculate GIC in steady-state in a transformer assuming a uniform eastward geoelectric field of 1 V/km ( $GIC_E$ ) while the northward geoelectric field is zero. Similarly,  $GIC_N$  can be obtained for a uniform northward geoelectric field of 1 V/km while the eastward geoelectric field is zero.  $GIC_E$  and  $GIC_N$  are the normalized GIC contributions for the transformer under consideration.

If the earth conductivity is assumed to be uniform (or laterally uniform) in the transmission system of interest, then the transformer GIC (in A/phase) for any value of  $E_E(t)$  and  $E_N(t)$  can be calculated using (2) [2].

$$GIC(t) = |E(t)| \times \{GIC_E \times \sin(\varphi(t)) + GIC_N \times \cos(\varphi(t))\} \quad (2)$$

where,

$$|E(t)| = \sqrt{E_E^2(t) + E_N^2(t)} \quad (3)$$

$$\varphi(t) = \tan^{-1} \left( \frac{E_E(t)}{E_N(t)} \right) \quad (4)$$

$$GIC(t) = E_E(t) \times GIC_E + E_N(t) \times GIC_N \quad (5)$$

$GIC_N$  is the effective GIC due to a northward geoelectric field of 1 V/km, and  $GIC_E$  is the effective GIC due to an eastward geoelectric field of 1 V/km. The units for  $GIC_N$  and  $GIC_E$  are A/phase per V/km).

The geoelectric field time series  $E_N(t)$  and  $E_E(t)$  is obtained, for instance, from the reference geomagnetic field time series (from [7] and/or [8]) after the appropriate geomagnetic latitude scaling factor  $\alpha$  is applied.<sup>8</sup> The reference geoelectric field time series is calculated using the reference earth model. When using this geoelectric field time series where a different earth model is applicable, it should be scaled with the appropriate conductivity scaling factor  $\beta$ .<sup>9</sup> Alternatively, the geoelectric field can be calculated from the reference geomagnetic field time series after the appropriate geomagnetic latitude scaling factor  $\alpha$  is applied and the appropriate earth model is used. In such case, the conductivity scaling factor  $\beta$  is not applied because it is already accounted for by the use of the appropriate earth model.

Applying (5) to each point in  $E_N(t)$  and  $E_E(t)$  results in  $GIC(t)$ .

### GIC(t) Calculation Example

Let us assume that from the steady-state solution, the effective GIC in this transformer is  $GIC_E = -20$  A/phase if  $E_N=0$ ,  $E_E=1$  V/km and  $GIC_N = 26$  A/phase if  $E_N=1$  V/km,  $E_E=0$ . Let us also assume the geomagnetic field time

<sup>8</sup> The geomagnetic factor  $\alpha$  is described in [2] and is used to scale the geomagnetic field according to geomagnetic latitude. The lower the geomagnetic latitude (closer to the equator), the lower the amplitude of the geomagnetic field.

<sup>9</sup> The conductivity scaling factor  $\beta$  is described in [2], and is used to scale the geoelectric field according to the conductivity of different physiographic regions. Lower conductivity results in higher  $\beta$  scaling factors.

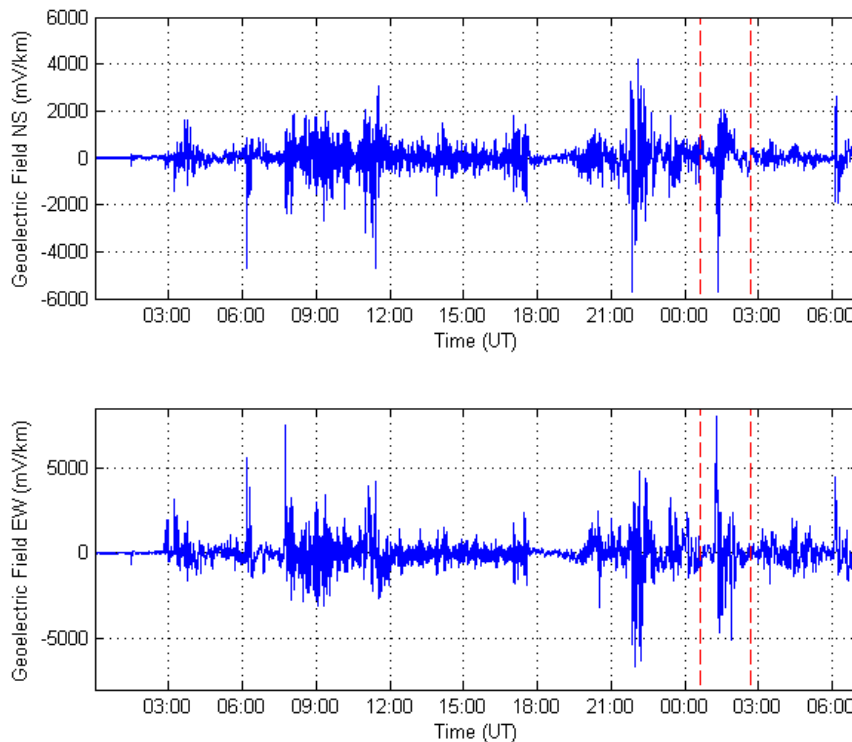
series corresponds to a geomagnetic latitude where  $\alpha = 1$  and that the earth conductivity corresponds to the reference earth model in [7]. The resulting geoelectric field time series is shown in Figure 4. Therefore:

$$GIC(t) = E_E(t) \times GIC_E + E_N(t) \times GIC_N \text{ (A/Phase)} \quad (6)$$

$$GIC(t) = -E_E(t) \times 20 + E_N(t) \times 26 \text{ (A/Phase)} \quad (7)$$

The resulting GIC waveform  $GIC(t)$  is shown in Figures 5 and 6 and can subsequently be used for thermal analysis.

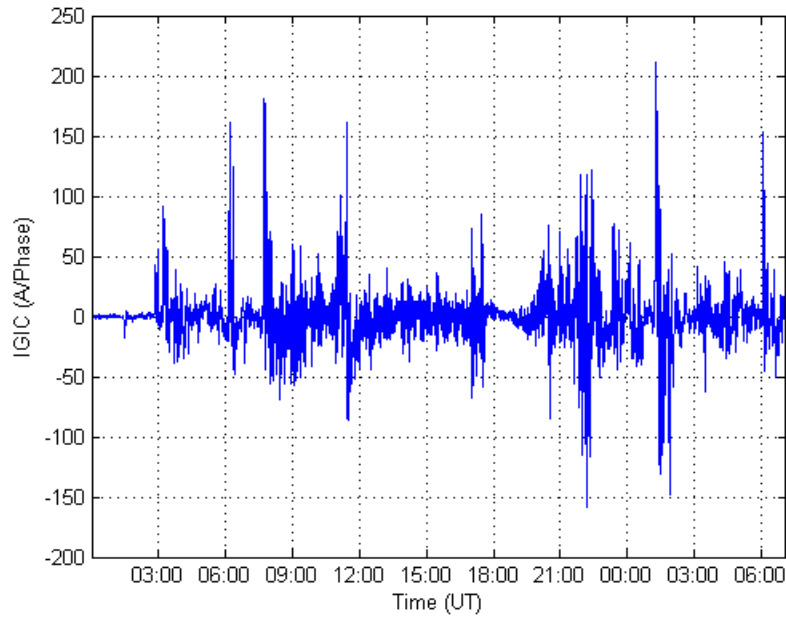
It should be emphasized that even for the same reference event, the  $GIC(t)$  waveform in every transformer will be different, depending on the location within the system and the number and orientation of the circuits connecting to the transformer station. Assuming a single generic  $GIC(t)$  waveform to test all transformers is incorrect.



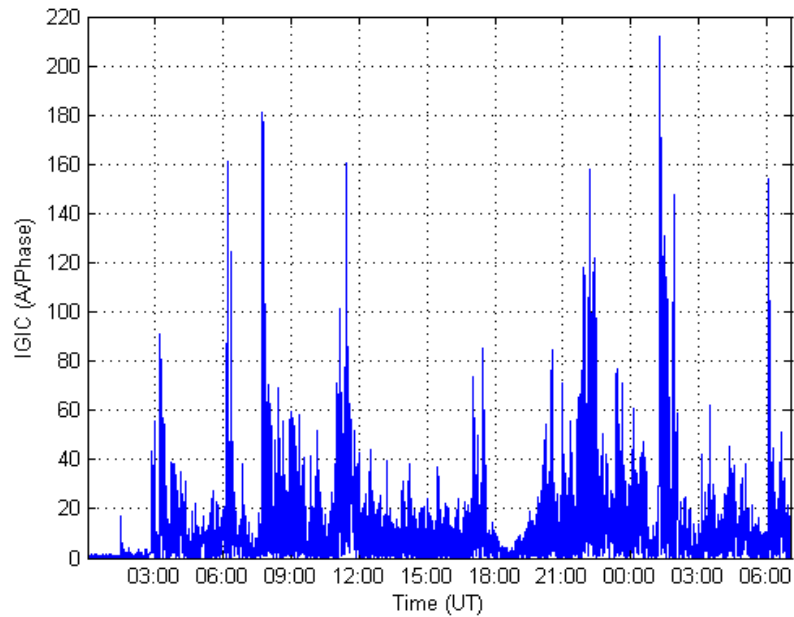
**Figure 4: Calculated Geoelectric Field  $E_N(t)$  and  $E_E(t)$  Assuming  $\alpha=1$  and  $\beta=1$  (Reference Earth Model)**

Zoom area for subsequent graphs is highlighted

Dashed lines approximately show the close-up area for subsequent Figures



**Figure 5: Calculated GIC(t) Assuming  $\alpha=1$  and  $\beta=1$  Reference Earth Model**



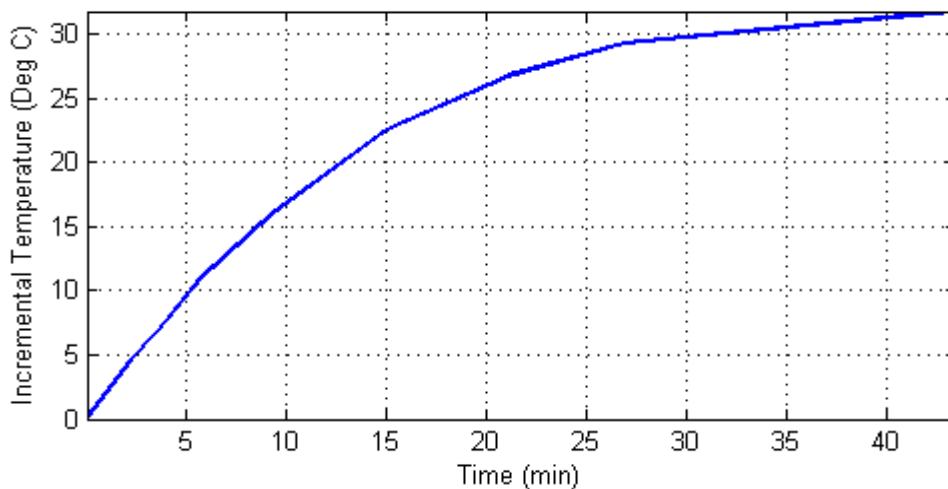
**Figure 6: Calculated Magnitude of GIC(t) Assuming  $\alpha=1$  and  $\beta=1$  Reference Earth Model**

**Transformer Thermal Assessment Examples**

There are two basic ways to carry out a transformer thermal analysis once the GIC time series  $GIC(t)$  is known for a given transformer: 1) calculating the thermal response as a function of time; and 2) using manufacturer’s capability curves.

**Example 1: Calculating thermal response as a function of time using a thermal response tool**

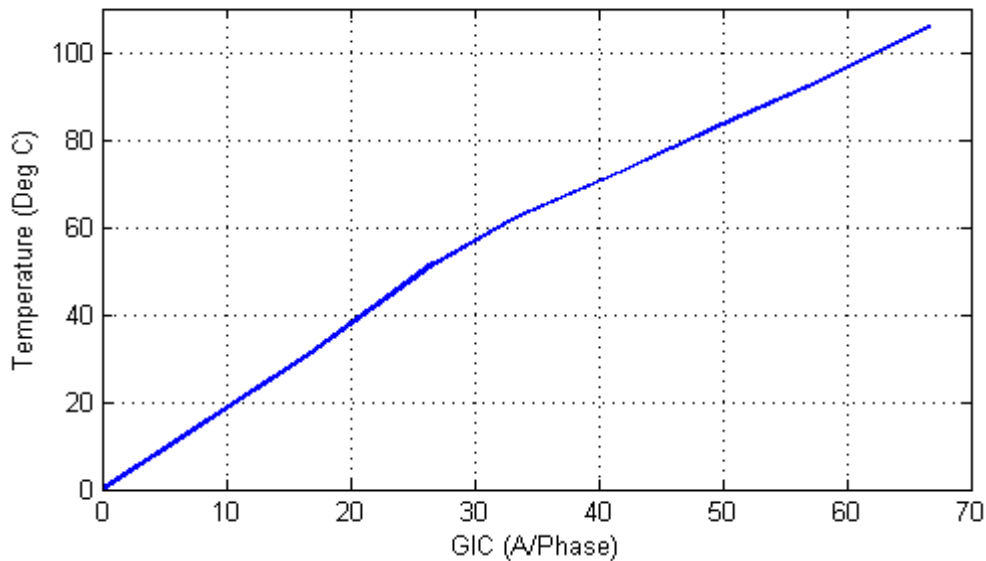
The thermal step response of the transformer can be obtained for both winding and metallic part hot spots from: 1) measurements; 2) manufacturer’s calculations; or 3) generic published values. Figure 7 shows the measured metallic hot spot thermal response to a dc step of 16.67 A/phase of the top yoke clamp from [9] that will be used in this example. Figure 8 shows the measured incremental temperature rise (asymptotic response) of the same hot spot to long duration GIC steps.<sup>10</sup>



**Figure 7: Thermal Step Response to a 16.67 Amperes per Phase dc Step  
 Metallic hot spot heating**

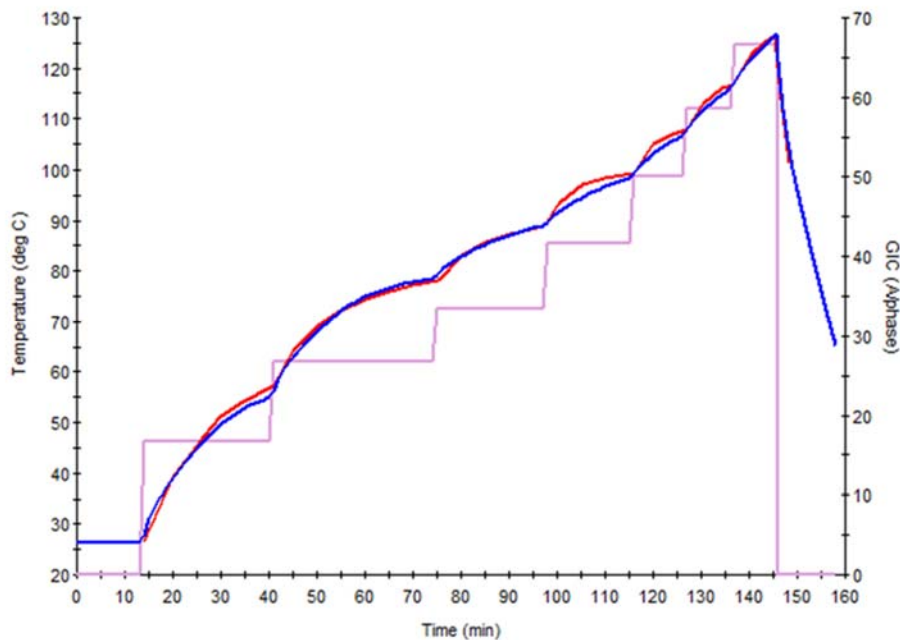
<sup>10</sup> Heating of bulk oil due to the hot spot temperature increase is not included in the asymptotic response because the time constant of bulk oil heating is at least an order of magnitude larger than the time constants of hot spot heating.





**Figure 8: Asymptotic Thermal Step Response**  
 Metallic hot spot heating

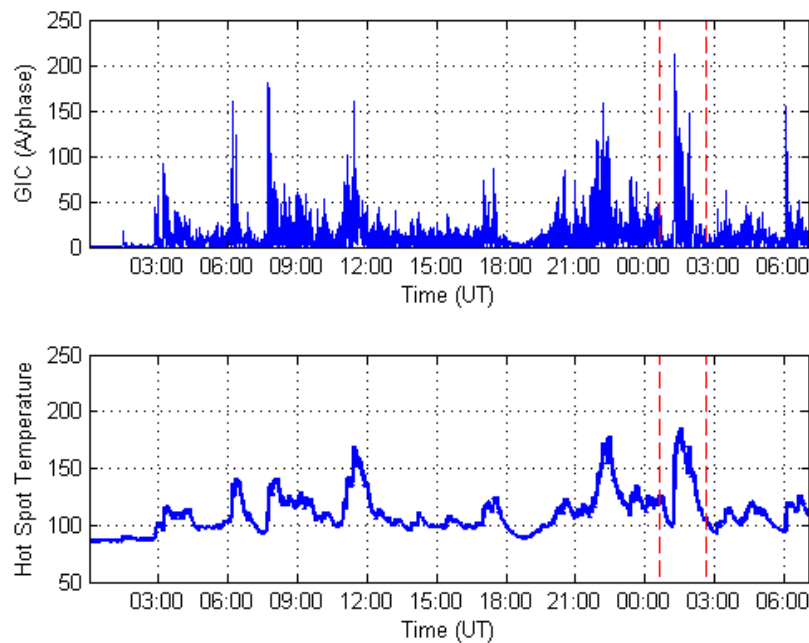
The step response in Figure 7 was obtained from the first GIC step of the tests carried out in [6]. The asymptotic thermal response in Figure 8 was obtained from the final or near-final temperature values after each subsequent GIC step. Figure 9 shows a comparison between measured temperatures and the calculated temperatures using the thermal response model used in the rest of this discussion.



**Figure 9: Comparison of measured temperatures (red) and simulation results (blue)**  
 Injected current is represented by magenta

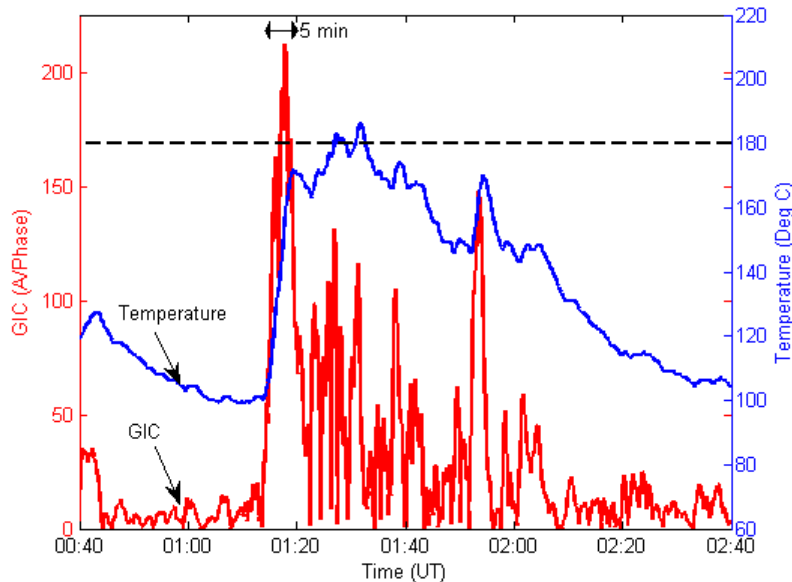
To obtain the thermal response of the transformer to a GIC waveform such as the one in Figure 6, a thermal response model is required. To create a thermal response model, the measured or manufacturer-calculated transformer thermal step responses (winding and metallic part) for various GIC levels are required. The GIC(t) time series or waveform is then applied to the thermal model to obtain the incremental temperature rise as a function of time  $\theta(t)$  for the GIC(t) waveform. The total temperature is calculated by adding the oil temperature, for example, at full load.

Figure 10 illustrates the calculated GIC(t) and the corresponding metallic hot spot temperature time series  $\theta(t)$ . Figure 11 illustrates a close-up view of the peak transformer temperatures calculated in this example.



**Figure 10: Magnitude of GIC(t) and Metallic Hot Spot Temperature  $\theta(t)$  Assuming Full Load Oil Temperature of 85.3°C (40°C ambient)**

Dashed lines approximately show the close-up area for subsequent figures



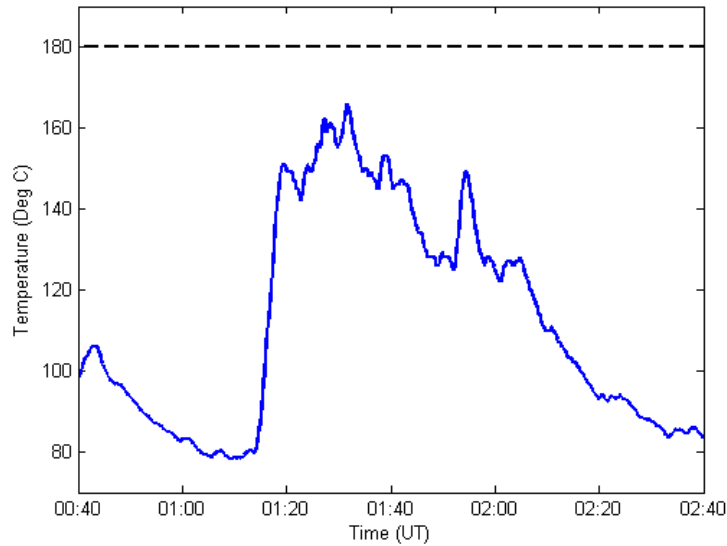
**Figure 11: Close-up of Metallic Hot Spot Temperature Assuming a Full Load**  
Blue trace is  $\theta(t)$  Red trace is  $GIC(t)$

In this example, the IEEE Std C57.91-2011 emergency loading hot spot threshold of 200°C for metallic hot spot heating is not exceeded. Peak temperature is 186°C. The IEEE standard is silent as to whether the temperature can be higher than 200°C for less than 30 minutes. Manufacturers can provide guidance on individual transformer capability.

It is not unusual to use a lower temperature threshold of 180°C to account for calculation and data margins, as well as transformer age and condition. Figure 11 shows that 180°C will be exceeded for 5 minutes.

At 75% loading, the initial temperature is 64.6°C rather than 85.3°C, and the hot spot temperature peak is 165°C, well below the 180°C threshold (see Figure 12).

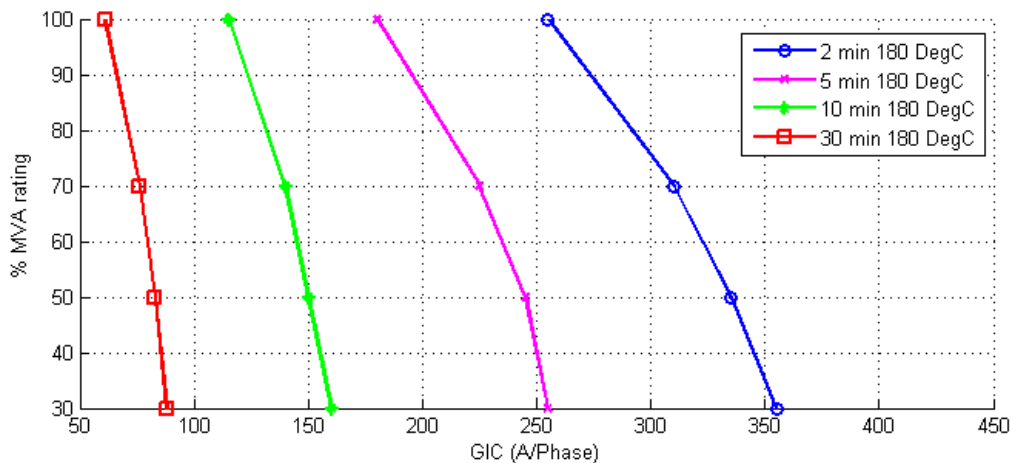
If a conservative threshold of 160°C were used to account for the age and condition of the transformer, then the full load limits would be exceeded for approximately 22 minutes.



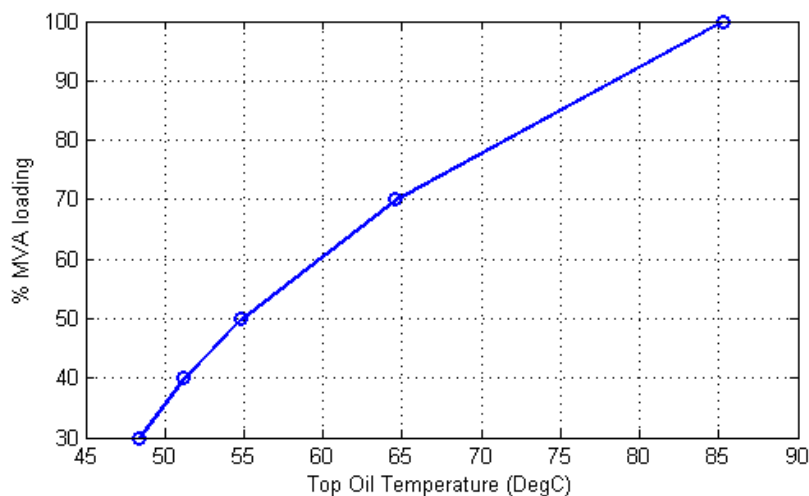
**Figure 12: Close-up of Metallic Hot Spot Temperature Assuming a 75% Load**  
Oil temperature of 64.5°C

**Example 2: Using a Manufacturer's Capability Curves**

The capability curves used in this example are shown in Figure 13. To maintain consistency with the previous example, these particular capability curves have been reconstructed from the thermal step response shown in Figures 7 and 8, and the simplified loading curve shown in Figure 14 (calculated using formulas from IEEE Std C57.91-2011).



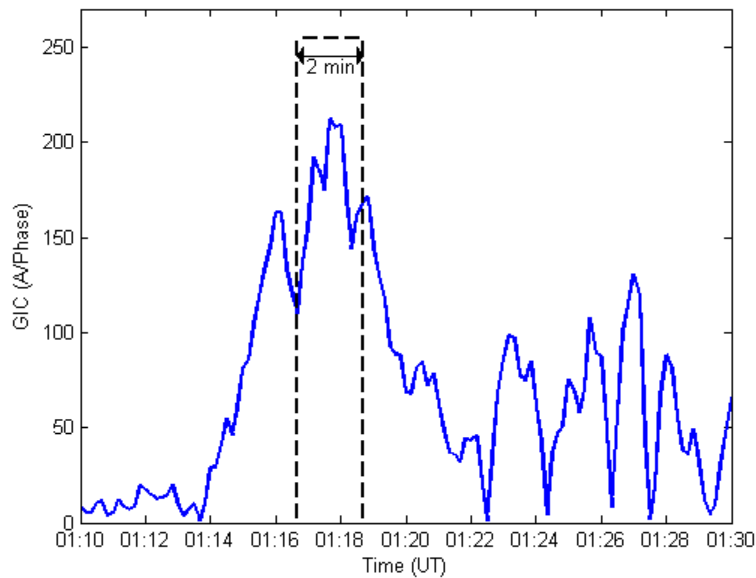
**Figure 13: Capability Curve of a Transformer Based on the Thermal Response Shown in Figures 8 and 9**



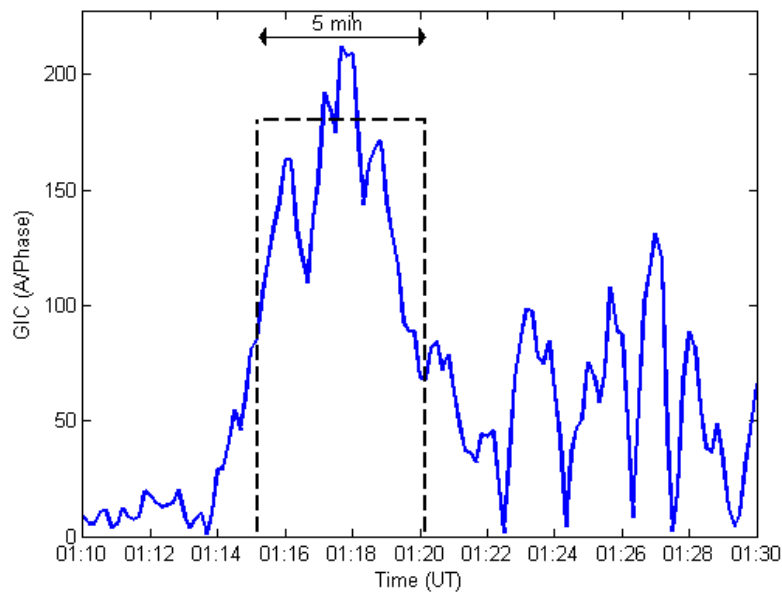
**Figure 14: Simplified Loading Curve Assuming 40°C Ambient Temperature**

The basic notion behind the use of capability curves is to compare the calculated GIC in a transformer with the limits at different GIC pulse widths. A narrow GIC pulse has a higher limit than a longer duration or wider one. If the calculated GIC and assumed pulse width falls below the appropriate pulse width curve, then the transformer is within its capability.

To use these curves, it is necessary to estimate an equivalent square pulse that matches the waveform of GIC(t), generally at a GIC(t) peak. Figure 15 shows a close-up of the GIC near its highest peak superimposed to a 255 Amperes per phase, 2 minute pulse at 100% loading from Figure 13. Since a narrow 2-minute pulse is not representative of GIC(t) in this case, a 5 minute pulse with an amplitude of 180 A/phase at 100% loading has been superimposed on Figure 16. It should be noted that a 255 A/phase, 2 minute pulse is equivalent to a 180 A/phase 5 minute pulse from the point of view of transformer capability. Deciding what GIC pulse is equivalent to the portion of GIC(t) under consideration is a matter of engineering judgment.



**Figure 15: Close-up of GIC(t) and a 2 minute 255 A/phase GIC pulse at full load**



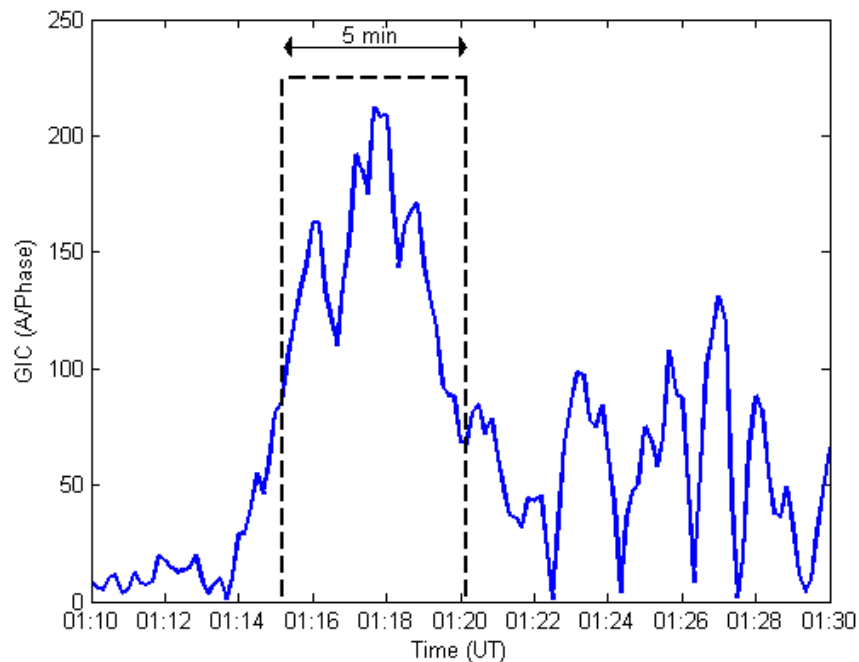
**Figure 16: Close-up of GIC(t) and a Five Minute 180 A/phase GIC Pulse at Full Load**

When using a capability curve, it should be understood that the curve is derived assuming that there is no hot spot heating due to prior GIC at the time the GIC pulse occurs (only an initial temperature due to loading). Therefore, in addition to estimating the equivalent pulse that matches GIC(t), prior metallic hot

spot heating must be accounted for. From these considerations, it is unclear whether the capability curves would be exceeded at full load with a 180°C threshold in this example.

At 70% loading, the two and five minute pulses from Figure 13 would have amplitudes of 310 and 225 A/phase, respectively. The 5 minute pulse is illustrated in Figure 17. In this case, judgment is also required to assess if the GIC(t) is within the capability curve for 70% loading. In general, capability curves are easier to use when GIC(t) is substantially above, or clearly below the GIC thresholds for a given pulse duration.

If a conservative threshold of 160°C were used to account for the age and condition of the transformer, then a new set of capability curves would be required.



**Figure 17: Close-up of GIC(t) and a 5 Minute 225 A/phase GIC Pulse Assuming 70% Load**

## References

- [1] "IEEE Guide for ~~loading mineral oil immersed transformers~~Loading Mineral-Oil-Immersed Transformers and ~~step voltage regulators~~Step-Voltage Regulators." IEEE Std C57.91-2011 (Revision of IEEE Std C57.91-1995). March 7, 2012.
- [2] "Application Guide: Computing Geomagnetically-Induced Current in the Bulk-Power System," NERC. December 2013. Available at: [http://www.nerc.com/comm/PC/Geomagnetic%20Disturbance%20Task%20Force%20GMDTF%202013/GIC%20Application%20Guide%202013\\_approved.pdf](http://www.nerc.com/comm/PC/Geomagnetic%20Disturbance%20Task%20Force%20GMDTF%202013/GIC%20Application%20Guide%202013_approved.pdf).
- [3] "Screening Criterion for Transformer Thermal Impact Assessment" Developed by the Project 2013-03 (Geomagnetic Disturbance) standard drafting team. October 2017. Available at: <http://www.nerc.com/pa/Stand/Pages/Project-2013-03-Geomagnetic-Disturbance-Mitigation.aspx>.
- [4] "IEEE Guide for Establishing Power Transformer Capability while under Geomagnetic Disturbances." IEEE Std C57.163-2015. October 26, 2015.
- [5] Girgis, R.; Vedante, K. "Methodology for evaluating the impact of GIC and GIC capability of power transformer designs." IEEE PES Power and Energy Society 2013 General Meeting Proceedings. Vancouver, Canada.
- [6] Marti, L.; Rezaei-Zare, A.; and Narang, A. "Simulation of Transformer Hotspot Heating due to Geomagnetically Induced Currents." IEEE Transactions on Power Delivery, Vol.28, No.1. pp 320-327. January 2013.
- [7] "Benchmark Geomagnetic Disturbance Event Description" white paper. Developed by the Project 2013-03 (Geomagnetic Disturbance) standard drafting team. May 2016. Available at: <http://www.nerc.com/pa/Stand/Pages/Project-2013-03-Geomagnetic-Disturbance-Mitigation.aspx>.
- [8] "Supplemental Geomagnetic Disturbance Event Description" white paper. Developed by the Project 2013-03 (Geomagnetic Disturbance) standard drafting team. October 2017. Available at: <http://www.nerc.com/pa/Stand/Pages/Project-2013-03-Geomagnetic-Disturbance-Mitigation.aspx>.
- [9] Lahtinen, ~~Matti Jarmo~~; and Elovaara, J. "GIC occurrences and GIC test for 400 kV system transformer" IEEE Transactions on Power Delivery, Vol. 17, No. 2. pp 555-561. April 2002.



# Violation Risk Factor and Violation Severity Level Justifications

## TPL-007-2 – Transmission System Planned Performance for Geomagnetic Disturbance Events

This document provides the Standard Drafting Team's (SDT) justification for assignment of Violation Risk Factors (VRFs) and Violation Severity Levels (VSLs) for each requirement in TPL-007-2 – Transmission System Planned Performance for Geomagnetic Disturbance Events. Each requirement is assigned a VRF and a VSL. These elements support the determination of an initial value range for the Base Penalty Amount regarding violations of requirements in FERC-approved Reliability Standards, as defined in the ERO Sanction Guidelines. The SDT applied the following NERC criteria and FERC Guidelines when proposing VRFs and VSLs for the requirements under this project.

### NERC Criteria - Violation Risk Factors

#### High Risk Requirement

A requirement that, if violated, could directly cause or contribute to Bulk Electric System instability, separation, or a cascading sequence of failures, or could place the Bulk Electric System at an unacceptable risk of instability, separation, or cascading failures; or, a requirement in a planning time frame that, if violated, could, under emergency, abnormal, or restorative conditions anticipated by the preparations, directly cause or contribute to Bulk Electric System instability, separation, or a cascading sequence of failures, or could place the Bulk Electric System at an unacceptable risk of instability, separation, or cascading failures, or could hinder restoration to a normal condition.

#### Medium Risk Requirement

A requirement that, if violated, could directly affect the electrical state or the capability of the Bulk Electric System, or the ability to effectively monitor and control the Bulk Electric System. However, violation of a medium risk requirement is unlikely to lead to Bulk Electric System instability, separation, or cascading failures; or, a requirement in a planning time frame that, if violated, could, under emergency, abnormal, or restorative conditions anticipated by the preparations, directly and adversely affect the electrical state or capability of the Bulk Electric System, or the ability to effectively monitor, control, or restore the Bulk Electric System. However, violation of a medium risk requirement is unlikely, under emergency, abnormal, or restoration conditions anticipated by the preparations, to lead to Bulk Electric System instability, separation, or cascading failures, nor to hinder restoration to a normal condition.

### **Lower Risk Requirement**

A requirement that is administrative in nature and a requirement that, if violated, would not be expected to adversely affect the electrical state or capability of the Bulk Electric System, or the ability to effectively monitor and control the Bulk Electric System; or, a requirement that is administrative in nature and a requirement in a planning time frame that, if violated, would not, under the emergency, abnormal, or restorative conditions anticipated by the preparations, be expected to adversely affect the electrical state or capability of the Bulk Electric System, or the ability to effectively monitor, control, or restore the Bulk Electric System.

## **FERC Violation Risk Factor Guidelines**

### **Guideline (1) – Consistency with the Conclusions of the Final Blackout Report**

The Commission seeks to ensure that VRFs assigned to Requirements of Reliability Standards in these identified areas appropriately reflect their historical critical impact on the reliability of the Bulk-Power System. In the VSL Order, FERC listed critical areas (from the Final Blackout Report) where violations could severely affect the reliability of the Bulk-Power System:

- Emergency operations
- Vegetation management
- Operator personnel training
- Protection systems and their coordination
- Operating tools and backup facilities
- Reactive power and voltage control
- System modeling and data exchange
- Communication protocol and facilities
- Requirements to determine equipment ratings
- Synchronized data recorders

- Clearer criteria for operationally critical facilities
- Appropriate use of transmission loading relief.

**Guideline (2) – Consistency within a Reliability Standard**

The Commission expects a rational connection between the sub-Requirement VRF assignments and the main Requirement VRF assignment.

**Guideline (3) – Consistency among Reliability Standards**

The Commission expects the assignment of VRFs corresponding to requirements that address similar reliability goals in different Reliability Standards would be treated comparably.

**Guideline (4) – Consistency with NERC’s Definition of the Violation Risk Factor Level**

Guideline (4) was developed to evaluate whether the assignment of a particular VRF level conforms to NERC’s definition of that risk level.

**Guideline (5) – Treatment of Requirements that Co-mingle More Than One Obligation**

Where a single Requirement co-mingles a higher risk reliability objective and a lesser risk reliability objective, the VRF assignment for such requirements must not be watered down to reflect the lower risk level associated with the less important objective of the Reliability Standard.

**NERC Criteria - Violation Severity Levels**

VSLs define the degree to which compliance with a requirement was not achieved. Each requirement must have at least one VSL. While it is preferable to have four VSLs for each requirement, some requirements do not have multiple “degrees” of noncompliant performance and may have only one, two, or three VSLs.

VSLs should be based on NERC’s overarching criteria shown in the table below:

Lower VSL	Moderate VSL	High VSL	Severe VSL
The performance or product measured almost meets the full intent of the requirement.	The performance or product measured meets the majority of the intent of the requirement.	The performance or product measured does not meet the majority of the intent of the requirement, but does meet some of the intent.	The performance or product measured does not substantively meet the intent of the requirement.

### FERC Order of Violation Severity Levels

FERC’s VSL guidelines are presented below, followed by an analysis of whether the VSLs proposed for each requirement in the standard meet the FERC Guidelines for assessing VSLs:

#### Guideline 1 – Violation Severity Level Assignments Should Not Have the Unintended Consequence of Lowering the Current Level of Compliance

Compare the VSLs to any prior levels of non-compliance and avoid significant changes that may encourage a lower level of compliance than was required when levels of non-compliance were used.

#### Guideline 2 – Violation Severity Level Assignments Should Ensure Uniformity and Consistency in the Determination of Penalties

A violation of a “binary” type requirement must be a “Severe” VSL.

Do not use ambiguous terms such as “minor” and “significant” to describe noncompliant performance.

#### Guideline 3 – Violation Severity Level Assignment Should Be Consistent with the Corresponding Requirement

VSLs should not expand on what is required in the requirement.

**Guideline 4 – Violation Severity Level Assignment Should Be Based on A Single Violation, Not on A Cumulative Number of Violations**

Unless otherwise stated in the requirement, each instance of non-compliance with a requirement is a separate violation. Section 4 of the Sanction Guidelines states that assessing penalties on a per-violation per-day basis is the “default” for penalty calculations.

<b>VRF Justifications – TPL-007-2, R1</b>	
<b>Proposed VRF</b>	<b>Low</b>
FERC VRF G1 Discussion	Guideline 1- Consistency w/ Blackout Report. N/A
FERC VRF G2 Discussion	Guideline 2- Consistency within a Reliability Standard. The requirement has no sub-requirements so a single VRF was assigned.
FERC VRF G3 Discussion	Guideline 3- Consistency among Reliability Standards. A VRF of Lower is consistent with Reliability Standard TPL-001-4 Requirement R7, which requires the Planning Coordinator, in conjunction with each of its Transmission Planners, to identify each entity’s individual and joint responsibilities for performing required studies for the Planning Assessment. Proposed TPL-007-2 Requirement R1 requires Planning Coordinators, in conjunction with Transmission Planners, to identify individual and joint responsibilities for maintaining models and performing studies needed to complete the benchmark and supplemental GMD Vulnerability Assessments, and implementing process(es) to obtain GMD measurement data as specified in the Standard.
FERC VRF G4 Discussion	Guideline 4- Consistency with NERC Definitions of VRFs. A VRF of Lower is consistent with the NERC VRF definition. The requirement for identifying individual and joint responsibilities of the Planning Coordinator and each of the Transmission Planners in the Planning Coordinator’s planning area for maintaining models, performing GMD studies, and obtaining GMD measurement data, if violated, would not be expected to adversely affect the electrical state or capability of the Bulk Electric System, or the ability to effectively monitor, control, or restore the Bulk Electric System under conditions of a GMD event.

## VRF Justifications – TPL-007-2, R1

Proposed VRF	Low
FERC VRF G5 Discussion	Guideline 5- Treatment of Requirements that Co-mingle More than One Obligation. The requirement contains one objective, therefore a single VRF is assigned.

Proposed VSLs – TPL-007-2, R1			
Lower	Moderate	High	Severe
N/A	N/A	N/A	The Planning Coordinator, in conjunction with its Transmission Planner(s), failed to determine and identify individual or joint responsibilities of the Planning Coordinator and Transmission Planner(s) in the Planning Coordinator’s planning area for maintaining models, performing the study or studies needed to complete benchmark and supplemental GMD Vulnerability Assessments, and implementing process(es) to obtain GMD measurement data as specified in this standard.

VSL Justifications – TPL-007-2, R1	
NERC VSL Guidelines	Consistent with NERC's VSL Guidelines. The requirement does not have elements or quantities to evaluate degrees of compliance. A VSL of Severe is assigned for non-compliance.
FERC VSL G1 Violation Severity Level Assignments Should Not Have the Unintended Consequence of Lowering the Current Level of Compliance	The VSL is not changed in TPL-007-2.
FERC VSL G2 Violation Severity Level Assignments Should Ensure Uniformity and Consistency in the Determination of Penalties Guideline 2a: The Single Violation Severity Level Assignment Category for "Binary" Requirements Is Not Consistent Guideline 2b: Violation Severity Level Assignments that Contain Ambiguous Language	<p>The proposed VSL is written to ensure uniformity and consistency in the determination of penalties.</p> <p>Guideline 2a: The proposed VSL is binary and assigned a Severe VSL.</p> <p>Guideline 2b: The proposed VSL does not use ambiguous terms, supporting uniformity and consistency in the determination of similar penalties for similar violations.</p>
FERC VSL G3 Violation Severity Level Assignment Should Be	The proposed VSL is worded consistently with the corresponding requirement.



<p>Consistent with the Corresponding Requirement</p>	
<p>FERC VSL G4 Violation Severity Level Assignment Should Be Based on A Single Violation, Not on A Cumulative Number of Violations</p>	<p>The proposed VSL is not based on a cumulative number of violations.</p>

VRF Justifications – TPL-007-2, R2	
Proposed VRF	High
FERC VRF G1 Discussion	Guideline 1- Consistency w/ Blackout Report: N/A
FERC VRF G2 Discussion	Guideline 2- Consistency within a Reliability Standard: The requirement has no sub-requirements so a single VRF was assigned.
FERC VRF G3 Discussion	Guideline 3- Consistency among Reliability Standards. A VRF of High is consistent with the VRF for Reliability Standard TPL-001-4 Requirement R1 as amended in NERC's filing dated August 29, 2014, which requires Transmission Planners and Planning Coordinators to maintain models within its respective planning area for performing studies needed to complete its Planning Assessment. Proposed TPL-007-2, Requirement R2 requires responsible entities to maintain System models and GIC System models of the responsible entity's planning area for performing the studies needed to complete benchmark and supplemental GMD Vulnerability Assessments.
FERC VRF G4 Discussion	Guideline 4- Consistency with NERC Definitions of VRFs. The VRF of High is consistent with the NERC VRF Definition. The System Models and GIC System Models serve as the foundation for all conditions and events that are required to be studied and evaluated in the benchmark and supplemental GMD Vulnerability Assessments. For this reason, failure to maintain models of the responsible entity's planning area for performing GMD studies could, under GMD conditions that are as severe as the benchmark and supplemental GMD event, place the Bulk Electric System at an unacceptable risk of instability, separation, or cascading failures.
FERC VRF G5 Discussion	Guideline 5- Treatment of Requirements that Co-mingle More than One Obligation. This requirement does not co-mingle a higher-risk reliability objective with a lesser- risk reliability objective.

Proposed VSLs – TPL-007-2, R2			
Lower	Moderate	High	Severe
N/A	N/A	The responsible entity did not maintain either System models or GIC System models of the responsible entity’s planning area for performing the studies needed to complete benchmark and supplemental GMD Vulnerability Assessments.	The responsible entity did not maintain both System models and GIC System models of the responsible entity’s planning area for performing the studies needed to complete benchmark and supplemental GMD Vulnerability Assessments.

VSL Justifications – TPL-007-2, R2	
NERC VSL Guidelines	Consistent with NERC's VSL Guidelines. The requirement may be described by elements or quantities to evaluate degrees of compliance. Two VSLs are specified for a graduated scale.
FERC VSL G1 Violation Severity Level Assignments Should Not Have the Unintended Consequence of Lowering the Current Level of Compliance	The VSL is not changed in TPL-007-2.

VSL Justifications – TPL-007-2, R2	
<p>FERC VSL G2 Violation Severity Level Assignments Should Ensure Uniformity and Consistency in the Determination of Penalties Guideline 2a: The Single Violation Severity Level Assignment Category for "Binary" Requirements Is Not Consistent Guideline 2b: Violation Severity Level Assignments that Contain Ambiguous Language</p>	<p>The proposed VSL is written to ensure uniformity and consistency in the determination of penalties.</p> <p>Guideline 2a: The proposed VSL is not binary.</p> <p>Guideline 2b: The proposed VSL does not use ambiguous terms, supporting uniformity and consistency in the determination of similar penalties for similar violations.</p>
<p>FERC VSL G3 Violation Severity Level Assignment Should Be Consistent with the Corresponding Requirement</p>	<p>The proposed VSL is worded consistently with the corresponding requirement.</p>
<p>FERC VSL G4 Violation Severity Level Assignment Should Be Based on A Single Violation, Not on A Cumulative Number of Violations</p>	<p>The proposed VSL is not based on a cumulative number of violations.</p>

VRF Justifications – TPL-007-2, R3	
Proposed VRF	Medium
FERC VRF G1 Discussion	Guideline 1- Consistency w/ Blackout Report: N/A
FERC VRF G2 Discussion	Guideline 2- Consistency within a Reliability Standard: The requirement has no sub-requirements so a single VRF was assigned.
FERC VRF G3 Discussion	Guideline 3- Consistency among Reliability Standards. A VRF of Medium is consistent with Reliability Standard TPL-001-4 Requirement R5 which requires Transmission Planners and Planning Coordinators to have criteria for acceptable System steady state voltage limits. Proposed TPL-007-2 Requirement R4 requires responsible entities to have criteria for acceptable System steady state voltage performance for its System during the benchmark GMD event; these criteria may be different from the voltage limits determined in Reliability Standard TPL-001-4 Requirement R5.
FERC VRF G4 Discussion	Guideline 4- Consistency with NERC Definitions of VRFs. The VRF of Medium is consistent with the NERC VRF Definition. Failure to have criteria for acceptable System steady state voltage limits for its System during a GMD planning event could directly and adversely affect the electrical state or capability of the Bulk Electric System, or the ability to effectively monitor, control, or restore the Bulk Electric System during an actual GMD event. However, it is unlikely that such a failure by itself would lead to Bulk Electric System instability, separation, or cascading.
FERC VRF G5 Discussion	Guideline 5- Treatment of Requirements that Co-mingle More than One Obligation. This requirement does not co-mingle a higher-risk reliability objective with a lesser- risk reliability objective.

Proposed VSLs – TPL-007-2, R3			
Lower	Moderate	High	Severe
N/A	N/A	N/A	The responsible entity did not have criteria for acceptable System steady state voltage performance for its System during the GMD events described in Attachment 1 as required.

VSL Justifications – TPL-007-2, R3	
NERC VSL Guidelines	Consistent with NERC's VSL Guidelines. The requirement does not have elements or quantities to evaluate degrees of compliance. A VSL of Severe is assigned for non-compliance.
FERC VSL G1 Violation Severity Level Assignments Should Not Have the Unintended Consequence of Lowering the Current Level of Compliance	The VSL is not changed in TPL-007-2.

VSL Justifications – TPL-007-2, R3	
<p>FERC VSL G2 Violation Severity Level Assignments Should Ensure Uniformity and Consistency in the Determination of Penalties Guideline 2a: The Single Violation Severity Level Assignment Category for "Binary" Requirements Is Not Consistent Guideline 2b: Violation Severity Level Assignments that Contain Ambiguous Language</p>	<p>The proposed VSL is written to ensure uniformity and consistency in the determination of penalties.</p> <p>Guideline 2a: The proposed VSL is binary and assigned a Severe VSL.</p> <p>Guideline 2b: The proposed VSL does not use ambiguous terms, supporting uniformity and consistency in the determination of similar penalties for similar violations.</p>
<p>FERC VSL G3 Violation Severity Level Assignment Should Be Consistent with the Corresponding Requirement</p>	<p>The proposed VSL is worded consistently with the corresponding requirement.</p>
<p>FERC VSL G4 Violation Severity Level Assignment Should Be Based on A Single Violation, Not on A Cumulative Number of Violations</p>	<p>The proposed VSL is not based on a cumulative number of violations.</p>

<b>VRF Justifications – TPL-007-2, R4</b>	
<b>Proposed VRF</b>	<b>High</b>
FERC VRF G1 Discussion	Guideline 1- Consistency w/ Blackout Report: N/A
FERC VRF G2 Discussion	Guideline 2- Consistency within a Reliability Standard: The requirement has no sub-requirements so a single VRF was assigned.
FERC VRF G3 Discussion	Guideline 3- Consistency among Reliability Standards. A VRF of High is consistent with Reliability Standard TPL-001-4 Requirement R2 which requires Transmission Planners and Planning Coordinators to prepare an annual Planning Assessment to ensure its portion of the Bulk Electric System meets performance criteria. Proposed TPL-007-2 Requirement R4 requires responsible entities to complete a benchmark GMD Vulnerability Assessment to ensure the system meets performance criteria during the benchmark GMD event.
FERC VRF G4 Discussion	Guideline 4- Consistency with NERC Definitions of VRFs. The VRF of High is consistent with the NERC VRF Definition. Failure to complete a benchmark GMD Vulnerability Assessment could, under GMD conditions that are as severe as the benchmark GMD event, place the Bulk Electric System at an unacceptable risk of instability, separation, or cascading failures.
FERC VRF G5 Discussion	Guideline 5- Treatment of Requirements that Co-mingle More than One Obligation. This requirement does not co-mingle a higher-risk reliability objective with a lesser- risk reliability objective.



Proposed VSLs – TPL-007-2, R4			
Lower	Moderate	High	Severe
<p>The responsible entity completed a benchmark GMD Vulnerability Assessment, but it was more than 60 calendar months and less than or equal to 64 calendar months since the last benchmark GMD Vulnerability Assessment.</p>	<p>The responsible entity's completed benchmark GMD Vulnerability Assessment failed to satisfy one of the elements listed in Requirement R4, Parts 4.1 through 4.3;</p> <p>OR</p> <p>The responsible entity completed a benchmark GMD Vulnerability Assessment, but it was more than 64 calendar months and less than or equal to 68 calendar months since the last benchmark GMD Vulnerability Assessment.</p>	<p>The responsible entity's completed benchmark GMD Vulnerability Assessment failed to satisfy two of the elements listed in Requirement R4, Parts 4.1 through 4.3;</p> <p>OR</p> <p>The responsible entity completed a benchmark GMD Vulnerability Assessment, but it was more than 68 calendar months and less than or equal to 72 calendar months since the last benchmark GMD Vulnerability Assessment.</p>	<p>The responsible entity's completed benchmark GMD Vulnerability Assessment failed to satisfy three of the elements listed in Requirement R4, Parts 4.1 through 4.3;</p> <p>OR</p> <p>The responsible entity completed a benchmark GMD Vulnerability Assessment, but it was more than 72 calendar months since the last benchmark GMD Vulnerability Assessment;</p> <p>OR</p> <p>The responsible entity does not have a completed benchmark GMD Vulnerability Assessment.</p>

VSL Justifications – TPL-007-2, R4	
NERC VSL Guidelines	Consistent with NERC's VSL Guidelines. The requirement may be described by elements or quantities to evaluate degrees of compliance. Four VSLs are specified for a graduated scale.
FERC VSL G1 Violation Severity Level Assignments Should Not Have the Unintended Consequence of Lowering the Current Level of Compliance	The VSL is not changed in TPL-007-2.
FERC VSL G2 Violation Severity Level Assignments Should Ensure Uniformity and Consistency in the Determination of Penalties Guideline 2a: The Single Violation Severity Level Assignment Category for "Binary" Requirements Is Not Consistent Guideline 2b: Violation Severity Level Assignments that Contain Ambiguous Language	<p>The proposed VSL is written to ensure uniformity and consistency in the determination of penalties.</p> <p>Guideline 2a: The proposed VSL is not binary.</p> <p>Guideline 2b: The proposed VSL does not use ambiguous terms, supporting uniformity and consistency in the determination of similar penalties for similar violations.</p>

VSL Justifications – TPL-007-2, R4	
FERC VSL G3 Violation Severity Level Assignment Should Be Consistent with the Corresponding Requirement	The proposed VSL is worded consistently with the corresponding requirement.
FERC VSL G4 Violation Severity Level Assignment Should Be Based on A Single Violation, Not on A Cumulative Number of Violations	The proposed VSL is not based on a cumulative number of violations.

VRF Justifications – TPL-007-2, R5	
<b>Proposed VRF</b>	<b>Medium</b>
FERC VRF G1 Discussion	Guideline 1- Consistency w/ Blackout Report: N/A
FERC VRF G2 Discussion	Guideline 2- Consistency within a Reliability Standard: The requirement has no sub-requirements so a single VRF was assigned.

<b>VRF Justifications – TPL-007-2, R5</b>	
<b>Proposed VRF</b>	<b>Medium</b>
FERC VRF G3 Discussion	Guideline 3- Consistency among Reliability Standards. A VRF of Medium is consistent with Reliability Standard MOD-032-1 Requirement R2 which requires applicable entities to provide modeling data to Transmission Planners and Planning Coordinators. A VRF of Medium is also consistent with Reliability Standard IRO-010-2 Requirement R3 which requires entities to provide data necessary for the Reliability Coordinator to perform its Operational Planning Analysis and Real-time Assessments. Proposed TPL-007-2 Requirement R5 requires responsible entities to provide specific geomagnetically-induced currents (GIC) flow information to Transmission Owners and Generator Owners for performing transformer thermal impact assessments.
FERC VRF G4 Discussion	Guideline 4- Consistency with NERC Definitions of VRFs. The VRF of Medium is consistent with the NERC VRF Definition. Failure to provide GIC flow information for the benchmark GMD event could directly and adversely affect the electrical state or capability of the Bulk Electric System, or the ability to effectively monitor, control, or restore the Bulk Electric System during a GMD event. However, it is unlikely that such a failure by itself would lead to Bulk Electric System instability, separation, or cascading.
FERC VRF G5 Discussion	Guideline 5- Treatment of Requirements that Co-mingle More than One Obligation. This requirement does not co-mingle a higher-risk reliability objective with a lesser- risk reliability objective.

Proposed VSLs – TPL-007-2, R5			
Lower	Moderate	High	Severe
The responsible entity provided the effective GIC time series, GIC(t), in response to written request, but did so more than 90 calendar days and less than or equal to 100 calendar days after receipt of a written request.	The responsible entity provided the effective GIC time series, GIC(t), in response to written request, but did so more than 100 calendar days and less than or equal to 110 calendar days after receipt of a written request.	The responsible entity provided the effective GIC time series, GIC(t), in response to written request, but did so more than 110 calendar days after receipt of a written request.	The responsible entity did not provide the maximum effective GIC value to the Transmission Owner and Generator Owner that owns each applicable BES power transformer in the planning area;  OR  The responsible entity did not provide the effective GIC time series, GIC(t), upon written request.

VSL Justifications – TPL-007-2, R5	
NERC VSL Guidelines	Consistent with NERC's VSL Guidelines. The requirement may be described by elements or quantities to evaluate degrees of compliance. Four VSLs are specified for a graduated scale.
FERC VSL G1 Violation Severity Level Assignments Should Not Have the Unintended Consequence of Lowering the Current Level of Compliance	The VLS is not changed in TPL-007-2.

VSL Justifications – TPL-007-2, R5	
<p>FERC VSL G2 Violation Severity Level Assignments Should Ensure Uniformity and Consistency in the Determination of Penalties Guideline 2a: The Single Violation Severity Level Assignment Category for "Binary" Requirements Is Not Consistent Guideline 2b: Violation Severity Level Assignments that Contain Ambiguous Language</p>	<p>The proposed VSL is written to ensure uniformity and consistency in the determination of penalties.</p> <p>Guideline 2a: The proposed VSL is not binary.</p> <p>Guideline 2b: The proposed VSL does not use ambiguous terms, supporting uniformity and consistency in the determination of similar penalties for similar violations.</p>
<p>FERC VSL G3 Violation Severity Level Assignment Should Be Consistent with the Corresponding Requirement</p>	<p>The proposed VSL is worded consistently with the corresponding requirement.</p>
<p>FERC VSL G4 Violation Severity Level Assignment Should Be Based on A Single Violation, Not on A Cumulative Number of Violations</p>	<p>The proposed VSL is not based on a cumulative number of violations.</p>

VRF Justifications – TPL-007-2, R6	
Proposed VRF	Medium
FERC VRF G1 Discussion	Guideline 1- Consistency w/ Blackout Report: N/A
FERC VRF G2 Discussion	Guideline 2- Consistency within a Reliability Standard: The requirement has no sub-requirements so a single VRF was assigned.
FERC VRF G3 Discussion	Guideline 3- Consistency among Reliability Standards. A VRF of Medium is consistent with Reliability Standard FAC-008-3 Requirement R6 which requires Transmission Owners and Generator Owners to have Facility Ratings for all solely and jointly owned Facilities that are consistent with the associated Facility Ratings methodology or documentation. Proposed TPL-007-2 Requirement R6 requires responsible entities to conduct a benchmark thermal impact assessment for solely and jointly owned applicable transformers and provide results including suggested actions to mitigate identified impacts to planning entities.
FERC VRF G4 Discussion	Guideline 4- Consistency with NERC Definitions of VRFs. The VRF of Medium is consistent with the NERC VRF Definition. Failure to conduct a benchmark transformer thermal impact assessment could directly and adversely affect the electrical state or capability of the Bulk Electric System, or the ability to effectively monitor, control, or restore the Bulk Electric System during a GMD event. However, it is unlikely that such a failure by itself would lead to Bulk Electric System instability, separation, or cascading.
FERC VRF G5 Discussion	Guideline 5- Treatment of Requirements that Co-mingle More than One Obligation. This requirement does not co-mingle a higher-risk reliability objective with a lesser- risk reliability objective.

Proposed VSLs – TPL-007-2, R6			
Lower	Moderate	High	Severe
<p>The responsible entity failed to conduct a benchmark thermal impact assessment for 5% or less or one of its solely owned and jointly owned applicable BES power transformers (whichever is greater) where the maximum effective GIC value provided in Requirement R5, Part 5.1, is 75 A or greater per phase;</p> <p>OR</p> <p>The responsible entity conducted a benchmark thermal impact assessment for its solely owned and jointly owned applicable BES power transformers where the maximum effective GIC value provided in Requirement R5, Part 5.1, is 75 A or greater per phase but did so more than 24 calendar months and less than or equal to 26 calendar months</p>	<p>The responsible entity failed to conduct a benchmark thermal impact assessment for more than 5% up to (and including) 10% or two of its solely owned and jointly owned applicable BES power transformers (whichever is greater) where the maximum effective GIC value provided in Requirement R5, Part 5.1, is 75 A or greater per phase;</p> <p>OR</p> <p>The responsible entity conducted a benchmark thermal impact assessment for its solely owned and jointly owned applicable BES power transformers where the maximum effective GIC value provided in Requirement R5, Part 5.1, is 75 A or greater per phase but did so more than 26 calendar months and less than</p>	<p>The responsible entity failed to conduct a benchmark thermal impact assessment for more than 10% up to (and including) 15% or three of its solely owned and jointly owned applicable BES power transformers (whichever is greater) where the maximum effective GIC value provided in Requirement R5, Part 5.1, is 75 A or greater per phase;</p> <p>OR</p> <p>The responsible entity conducted a benchmark thermal impact assessment for its solely owned and jointly owned applicable BES power transformers where the maximum effective GIC value provided in Requirement R5, Part 5.1, is 75 A or greater per phase but did so more than 28 calendar months and less than</p>	<p>The responsible entity failed to conduct a benchmark thermal impact assessment for more than 15% or more than three of its solely owned and jointly owned applicable BES power transformers (whichever is greater) where the maximum effective GIC value provided in Requirement R5, Part 5.1, is 75 A or greater per phase;</p> <p>OR</p> <p>The responsible entity conducted a benchmark thermal impact assessment for its solely owned and jointly owned applicable BES power transformers where the maximum effective GIC value provided in Requirement R5, Part 5.1, is 75 A or greater per phase but did so more than 30 calendar months of receiving</p>



<b>Proposed VSLs – TPL-007-2, R6</b>			
<b>Lower</b>	<b>Moderate</b>	<b>High</b>	<b>Severe</b>
of receiving GIC flow information specified in Requirement R5, Part 5.1.	or equal to 28 calendar months of receiving GIC flow information specified in Requirement R5, Part 5.1; OR The responsible entity failed to include one of the required elements as listed in Requirement R6, Parts 6.1 through 6.3.	or equal to 30 calendar months of receiving GIC flow information specified in Requirement R5, Part 5.1; OR The responsible entity failed to include two of the required elements as listed in Requirement R6, Parts 6.1 through 6.3.	GIC flow information specified in Requirement R5, Part 5.1; OR The responsible entity failed to include three of the required elements as listed in Requirement R6, Parts 6.1 through 6.3.

<b>VSL Justifications – TPL-007-2, R6</b>	
NERC VSL Guidelines	Consistent with NERC's VSL Guidelines. The requirement may be described by elements or quantities to evaluate degrees of compliance. Four VSLs are specified for a graduated scale.
FERC VSL G1 Violation Severity Level Assignments Should Not Have the Unintended Consequence of Lowering the Current Level of Compliance	The VSL is not changed in TPL-007-2.

VSL Justifications – TPL-007-2, R6	
<p>FERC VSL G2 Violation Severity Level Assignments Should Ensure Uniformity and Consistency in the Determination of Penalties Guideline 2a: The Single Violation Severity Level Assignment Category for "Binary" Requirements Is Not Consistent Guideline 2b: Violation Severity Level Assignments that Contain Ambiguous Language</p>	<p>The proposed VSL is written to ensure uniformity and consistency in the determination of penalties.</p> <p>Guideline 2a: The proposed VSL is not binary.</p> <p>Guideline 2b: The proposed VSL does not use ambiguous terms, supporting uniformity and consistency in the determination of similar penalties for similar violations.</p>
<p>FERC VSL G3 Violation Severity Level Assignment Should Be Consistent with the Corresponding Requirement</p>	<p>The proposed VSL is worded consistently with the corresponding requirement.</p>
<p>FERC VSL G4 Violation Severity Level Assignment Should Be Based on A Single Violation, Not on A Cumulative Number of Violations</p>	<p>The proposed VSL is not based on a cumulative number of violations.</p>

VRF Justifications – TPL-007-2, R7	
Proposed VRF	High
FERC VRF G1 Discussion	Guideline 1- Consistency w/ Blackout Report: N/A
FERC VRF G2 Discussion	Guideline 2- Consistency within a Reliability Standard: The requirement has no sub-requirements so a single VRF was assigned.
FERC VRF G3 Discussion	Guideline 3- Consistency among Reliability Standards. A VRF of High is consistent with Reliability Standard TPL-001-4 Requirement R2 which requires Transmission Planners and Planning Coordinators to include a Corrective Action Plan that addresses identified performance issues in the annual Planning Assessment. Proposed TPL-007-2 Requirement R7 requires responsible entities to develop a Corrective Action Plan when results of the benchmark GMD Vulnerability Assessment indicate that the System does not meet performance requirements. While Reliability Standard TPL-001-4 has a single requirement for performing the Planning Assessment and developing the Corrective Action Plan, proposed TPL-007-2 has split the requirements for performing a benchmark GMD Vulnerability Assessment and developing the Corrective Action Plan into two separate requirements because the transformer thermal impact assessments performed by Transmission Owners and Generator Owners must be considered. The sequencing with separate requirements follows a logical flow of the GMD Vulnerability Assessment process.
FERC VRF G4 Discussion	Guideline 4- Consistency with NERC Definitions of VRFs. The VRF of High is consistent with the NERC VRF Definition. Failure to develop a Corrective Action Plan that addresses issues identified in a GMD Vulnerability Assessment could, under GMD conditions that are as severe as the benchmark GMD event, place the Bulk Electric System at an unacceptable risk of instability, separation, or cascading failures.
FERC VRF G5 Discussion	Guideline 5- Treatment of Requirements that Co-mingle More than One Obligation. This requirement does not co-mingle a higher-risk reliability objective with a lesser- risk reliability objective.

<b>Proposed VSLs – TPL-007-2, R7</b>			
<b>Lower</b>	<b>Moderate</b>	<b>High</b>	<b>Severe</b>
The responsible entity's Corrective Action Plan failed to comply with one of the elements in Requirement R7, Parts 7.1 through 7.5.	The responsible entity's Corrective Action Plan failed to comply with two of the elements in Requirement R7, Parts 7.1 through 7.5.	The responsible entity's Corrective Action Plan failed to comply with three of the elements in Requirement R7, Parts 7.1 through 7.5.	The responsible entity's Corrective Action Plan failed to comply with four or more of the elements in Requirement R7, Parts 7.1 through 7.5; OR The responsible entity did not have a Corrective Action Plan as required by Requirement R7.

<b>VSL Justifications – TPL-007-2, R7</b>	
NERC VSL Guidelines	Consistent with NERC's VSL Guidelines. The requirement may be described by elements or quantities to evaluate degrees of compliance. Four VSLs are specified for a graduated scale.
FERC VSL G1 Violation Severity Level Assignments Should Not Have the Unintended Consequence of Lowering the Current Level of Compliance	The proposed requirement is a significant revision to TPL-007-2 to address the directive for Corrective Action Plan deadlines contained in FERC Order No. 830. There is no prior compliance obligation related to the directive. However, the requirement uses the same construct for a graduated scale as TPL-007-1 Requirement R7 and is similar to Reliability Standard TPL-001-4, Requirement R2.

VSL Justifications – TPL-007-2, R7	
<p>FERC VSL G2 Violation Severity Level Assignments Should Ensure Uniformity and Consistency in the Determination of Penalties Guideline 2a: The Single Violation Severity Level Assignment Category for "Binary" Requirements Is Not Consistent Guideline 2b: Violation Severity Level Assignments that Contain Ambiguous Language</p>	<p>The proposed VSL is written to ensure uniformity and consistency in the determination of penalties.</p> <p>Guideline 2a: The proposed VSL is not binary.</p> <p>Guideline 2b: The proposed VSL does not use ambiguous terms, supporting uniformity and consistency in the determination of similar penalties for similar violations.</p>
<p>FERC VSL G3 Violation Severity Level Assignment Should Be Consistent with the Corresponding Requirement</p>	<p>The proposed VSL is worded consistently with the corresponding requirement.</p>
<p>FERC VSL G4 Violation Severity Level Assignment Should Be Based on A Single Violation, Not on A Cumulative Number of Violations</p>	<p>The proposed VSL is not based on a cumulative number of violations.</p>

<b>VRF Justifications – TPL-007-2, R8</b>	
<b>Proposed VRF</b>	<b>High</b>
FERC VRF G1 Discussion	Guideline 1- Consistency w/ Blackout Report: N/A
FERC VRF G2 Discussion	Guideline 2- Consistency within a Reliability Standard: The requirement has no sub-requirements so a single VRF was assigned.
FERC VRF G3 Discussion	Guideline 3- Consistency among Reliability Standards. A VRF of High is consistent with Reliability Standard TPL-001-4 Requirement R2 which requires Transmission Planners and Planning Coordinators to prepare an annual Planning Assessment to ensure its portion of the Bulk Electric System meets performance criteria. The proposed requirement is also consistent with approved TPL-007-1 Requirement R4 (unchanged in proposed TPL-007-2 Requirement R4). Proposed TPL-007-2 Requirement R8 requires responsible entities to complete a supplemental GMD Vulnerability Assessment to assess system performance during a supplemental GMD event.
FERC VRF G4 Discussion	Guideline 4- Consistency with NERC Definitions of VRFs. The VRF of High is consistent with the NERC VRF Definition. Failure to complete a supplemental GMD Vulnerability Assessment could, under GMD conditions that are as severe as the supplemental GMD event, place the Bulk Electric System at an unacceptable risk of instability, separation, or cascading failures by precluding responsible entities from considering actions to mitigate risk of Cascading.
FERC VRF G5 Discussion	Guideline 5- Treatment of Requirements that Co-mingle More than One Obligation. This requirement does not co-mingle a higher-risk reliability objective with a lesser- risk reliability objective.

Proposed VSLs – TPL-007-2, R8			
Lower	Moderate	High	Severe
<p>The responsible entity's completed supplemental GMD Vulnerability Assessment failed to satisfy one of elements listed in Requirement R8, Parts 8.1 through 8.4;</p> <p>OR</p> <p>The responsible entity completed a supplemental GMD Vulnerability Assessment, but it was more than 60 calendar months and less than or equal to 64 calendar months since the last supplemental GMD Vulnerability Assessment.</p>	<p>The responsible entity's completed supplemental GMD Vulnerability Assessment failed to satisfy two of elements listed in Requirement R8, Parts 8.1 through 8.4;</p> <p>OR</p> <p>The responsible entity completed a supplemental GMD Vulnerability Assessment, but it was more than 64 calendar months and less than or equal to 68 calendar months since the last supplemental GMD Vulnerability Assessment.</p>	<p>The responsible entity's completed supplemental GMD Vulnerability Assessment failed to satisfy three of the elements listed in Requirement R8, Parts 8.1 through 8.4;</p> <p>OR</p> <p>The responsible entity completed a supplemental GMD Vulnerability Assessment, but it was more than 68 calendar months and less than or equal to 72 calendar months since the last supplemental GMD Vulnerability Assessment.</p>	<p>The responsible entity's completed supplemental GMD Vulnerability Assessment failed to satisfy four of the elements listed in Requirement R8, Parts 8.1 through 8.4;</p> <p>OR</p> <p>The responsible entity completed a supplemental GMD Vulnerability Assessment, but it was more than 72 calendar months since the last supplemental GMD Vulnerability Assessment;</p> <p>OR</p> <p>The responsible entity does not have a completed supplemental GMD Vulnerability Assessment.</p>

VSL Justifications – TPL-007-2, R8	
NERC VSL Guidelines	Consistent with NERC's VSL Guidelines. The requirement may be described by elements or quantities to evaluate degrees of compliance. Four VSLs are specified for a graduated scale.
FERC VSL G1 Violation Severity Level Assignments Should Not Have the Unintended Consequence of Lowering the Current Level of Compliance	There is no prior compliance obligation related to supplemental GMD Vulnerability Assessment. However, the requirement is similar to approved TPL-007-1, Requirement R4 (unchanged in proposed TPL-007-2 Requirement R4). That requirement also has a graduated scale for VSLs.
FERC VSL G2 Violation Severity Level Assignments Should Ensure Uniformity and Consistency in the Determination of Penalties Guideline 2a: The Single Violation Severity Level Assignment Category for "Binary" Requirements Is Not Consistent Guideline 2b: Violation Severity Level Assignments that Contain Ambiguous Language	<p>The proposed VSL is written to ensure uniformity and consistency in the determination of penalties.</p> <p>Guideline 2a: The proposed VSL is not binary.</p> <p>Guideline 2b: The proposed VSL does not use ambiguous terms, supporting uniformity and consistency in the determination of similar penalties for similar violations.</p>



<b>VSL Justifications – TPL-007-2, R8</b>	
<p>FERC VSL G3 Violation Severity Level Assignment Should Be Consistent with the Corresponding Requirement</p>	<p>The proposed VSL is worded consistently with the corresponding requirement.</p>
<p>FERC VSL G4 Violation Severity Level Assignment Should Be Based on A Single Violation, Not on A Cumulative Number of Violations</p>	<p>The proposed VSL is not based on a cumulative number of violations.</p>

<b>VRF Justifications – TPL-007-2, R9</b>	
<b>Proposed VRF</b>	<b>Medium</b>
FERC VRF G1 Discussion	Guideline 1- Consistency w/ Blackout Report: N/A
FERC VRF G2 Discussion	Guideline 2- Consistency within a Reliability Standard: The requirement has no sub-requirements so a single VRF was assigned.
FERC VRF G3 Discussion	Guideline 3- Consistency among Reliability Standards. A VRF of Medium is consistent with approved TPL-007-1 Requirement R5 (unchanged in proposed TPL-007-2 Requirement R5) which requires responsible entities to provide specific geomagnetically-induced currents (GIC) flow information to Transmission Owners and Generator Owners for performing transformer thermal impact assessments.

<b>VRF Justifications – TPL-007-2, R9</b>	
<b>Proposed VRF</b>	<b>Medium</b>
FERC VRF G4 Discussion	Guideline 4- Consistency with NERC Definitions of VRFs. The VRF of Medium is consistent with the NERC VRF Definition. Failure to provide GIC flow information for the supplemental GMD event could directly and adversely affect the electrical state or capability of the Bulk Electric System, or the ability to effectively monitor, control, or restore the Bulk Electric System during a GMD event. However, it is unlikely that such a failure by itself would lead to Bulk Electric System instability, separation, or cascading.
FERC VRF G5 Discussion	Guideline 5- Treatment of Requirements that Co-mingle More than One Obligation. This requirement does not co-mingle a higher-risk reliability objective with a lesser- risk reliability objective.

<b>Proposed VSLs – TPL-007-2, R9</b>			
<b>Lower</b>	<b>Moderate</b>	<b>High</b>	<b>Severe</b>
The responsible entity provided the effective GIC time series, GIC(t), in response to written request, but did so more than 90 calendar days and less than or equal to 100 calendar days after receipt of a written request.	The responsible entity provided the effective GIC time series, GIC(t), in response to written request, but did so more than 100 calendar days and less than or equal to 110 calendar days after receipt of a written request.	The responsible entity provided the effective GIC time series, GIC(t), in response to written request, but did so more than 110 calendar days after receipt of a written request.	The responsible entity did not provide the maximum effective GIC value to the Transmission Owner and Generator Owner that owns each applicable BES power transformer in the planning area;  OR  The responsible entity did not provide the effective GIC time series, GIC(t), upon written request.

<b>VSL Justifications – TPL-007-2, R9</b>	
NERC VSL Guidelines	Consistent with NERC's VSL Guidelines. The requirement may be described by elements or quantities to evaluate degrees of compliance. Four VSLs are specified for a graduated scale.

VSL Justifications – TPL-007-2, R9	
<p>FERC VSL G1 Violation Severity Level Assignments Should Not Have the Unintended Consequence of Lowering the Current Level of Compliance</p>	<p>There is no prior compliance obligation related to supplemental GMD Vulnerability Assessment. However, the requirement is similar to approved TPL-007-1, Requirement R5 (unchanged in proposed TPL-007-2 Requirement R5). That requirement also has a graduated scale for VSLs.</p>
<p>FERC VSL G2 Violation Severity Level Assignments Should Ensure Uniformity and Consistency in the Determination of Penalties Guideline 2a: The Single Violation Severity Level Assignment Category for "Binary" Requirements Is Not Consistent Guideline 2b: Violation Severity Level Assignments that Contain Ambiguous Language</p>	<p>The proposed VSL is written to ensure uniformity and consistency in the determination of penalties.</p> <p>Guideline 2a: The proposed VSL is not binary.</p> <p>Guideline 2b: The proposed VSL does not use ambiguous terms, supporting uniformity and consistency in the determination of similar penalties for similar violations.</p>
<p>FERC VSL G3 Violation Severity Level Assignment Should Be Consistent with the Corresponding Requirement</p>	<p>The proposed VSL is worded consistently with the corresponding requirement.</p>

VSL Justifications – TPL-007-2, R9	
<p>FERC VSL G4 Violation Severity Level Assignment Should Be Based on A Single Violation, Not on A Cumulative Number of Violations</p>	<p>The proposed VSL is not based on a cumulative number of violations.</p>

VRF Justifications – TPL-007-2, R10	
Proposed VRF	Medium
FERC VRF G1 Discussion	Guideline 1- Consistency w/ Blackout Report: N/A
FERC VRF G2 Discussion	Guideline 2- Consistency within a Reliability Standard: The requirement has no sub-requirements so a single VRF was assigned.
FERC VRF G3 Discussion	Guideline 3- Consistency among Reliability Standards. A VRF of Medium is consistent with approved TPL-007-1 Requirement R6 (unchanged in proposed TPL-007-2 Requirement R6), which requires responsible entities to conduct a benchmark thermal impact assessment for solely and jointly owned applicable transformers and provide results including suggested actions to mitigate identified impacts to planning entities.
FERC VRF G4 Discussion	Guideline 4- Consistency with NERC Definitions of VRFs. The VRF of Medium is consistent with the NERC VRF Definition. Failure to conduct a supplemental transformer thermal impact assessment could directly and adversely affect the electrical state or capability of the Bulk Electric System, or the ability to effectively monitor, control, or restore the Bulk Electric System during a GMD event. However, it is unlikely that such a failure by itself would lead to Bulk Electric System instability, separation, or cascading.

VRF Justifications – TPL-007-2, R10	
Proposed VRF	Medium
FERC VRF G5 Discussion	Guideline 5- Treatment of Requirements that Co-mingle More than One Obligation. This requirement does not co-mingle a higher-risk reliability objective with a lesser- risk reliability objective.

Proposed VSLs – TPL-007-2, R10			
Lower	Moderate	High	Severe
<p>The responsible entity failed to conduct a supplemental thermal impact assessment for 5% or less or one of its solely owned and jointly owned applicable BES power transformers (whichever is greater) where the maximum effective GIC value provided in Requirement R9, Part 9.1, is 85 A or greater per phase;</p> <p>OR</p> <p>The responsible entity conducted a supplemental thermal impact assessment for its solely owned and jointly owned applicable BES power</p>	<p>The responsible entity failed to conduct a supplemental thermal impact assessment for more than 5% up to (and including) 10% or two of its solely owned and jointly owned applicable BES power transformers (whichever is greater) where the maximum effective GIC value provided in Requirement R9, Part 9.1, is 85 A or greater per phase;</p> <p>OR</p> <p>The responsible entity conducted a supplemental thermal impact assessment for its solely owned and jointly</p>	<p>The responsible entity failed to conduct a supplemental thermal impact assessment for more than 10% up to (and including) 15% or three of its solely owned and jointly owned applicable BES power transformers (whichever is greater) where the maximum effective GIC value provided in Requirement R9, Part 9.1, is 85 A or greater per phase;</p> <p>OR</p> <p>The responsible entity conducted a supplemental thermal impact assessment for its solely owned and jointly</p>	<p>The responsible entity failed to conduct a supplemental thermal impact assessment for more than 15% or more than three of its solely owned and jointly owned applicable BES power transformers (whichever is greater) where the maximum effective GIC value provided in Requirement R9, Part 9.1, is 85 A or greater per phase;</p> <p>OR</p> <p>The responsible entity conducted a supplemental thermal impact assessment for its solely owned and jointly owned applicable BES power</p>

<b>Proposed VSLs – TPL-007-2, R10</b>			
<b>Lower</b>	<b>Moderate</b>	<b>High</b>	<b>Severe</b>
transformers where the maximum effective GIC value provided in Requirement R9, Part 9.1, is 85 A or greater per phase but did so more than 24 calendar months and less than or equal to 26 calendar months of receiving GIC flow information specified in Requirement R9, Part 9.1.	<p>owned applicable BES power transformers where the maximum effective GIC value provided in Requirement R9, Part 9.1, is 85 A or greater per phase but did so more than 26 calendar months and less than or equal to 28 calendar months of receiving GIC flow information specified in Requirement R9, Part 9.1</p> <p>OR</p> <p>The responsible entity failed to include one of the required elements as listed in Requirement R10, Parts 10.1 through 10.3.</p>	<p>owned applicable BES power transformers where the maximum effective GIC value provided in Requirement R9, Part 9.1, is 85 A or greater per phase but did so more than 28 calendar months and less than or equal to 30 calendar months of receiving GIC flow information specified in Requirement R9, Part 9.1;</p> <p>OR</p> <p>The responsible entity failed to include two of the required elements as listed in Requirement R10, Parts 10.1 through 10.3.</p>	<p>transformers where the maximum effective GIC value provided in Requirement R9, Part 9.1, is 85 A or greater per phase but did so more than 30 calendar months of receiving GIC flow information specified in Requirement R9, Part 9.1;</p> <p>OR</p> <p>The responsible entity failed to include three of the required elements as listed in Requirement R10, Parts 10.1 through 10.3.</p>

<b>VSL Justifications – TPL-007-2, R10</b>	
NERC VSL Guidelines	Consistent with NERC's VSL Guidelines. The requirement may be described by elements or quantities to evaluate degrees of compliance. Four VSLs are specified for a graduated scale.

VSL Justifications – TPL-007-2, R10	
<p>FERC VSL G1 Violation Severity Level Assignments Should Not Have the Unintended Consequence of Lowering the Current Level of Compliance</p>	<p>There is no prior compliance obligation related to supplemental thermal impact assessment. However, the requirement is similar to approved TPL-007-1, Requirement R6 (unchanged in proposed TPL-007-2 Requirement R6). That requirement also has a graduated scale for VSLs.</p>
<p>FERC VSL G2 Violation Severity Level Assignments Should Ensure Uniformity and Consistency in the Determination of Penalties Guideline 2a: The Single Violation Severity Level Assignment Category for "Binary" Requirements Is Not Consistent Guideline 2b: Violation Severity Level Assignments that Contain Ambiguous Language</p>	<p>The proposed VSL is written to ensure uniformity and consistency in the determination of penalties.</p> <p>Guideline 2a: The proposed VSL is not binary.</p> <p>Guideline 2b: The proposed VSL does not use ambiguous terms, supporting uniformity and consistency in the determination of similar penalties for similar violations.</p>
<p>FERC VSL G3 Violation Severity Level Assignment Should Be Consistent with the Corresponding Requirement</p>	<p>The proposed VSL is worded consistently with the corresponding requirement.</p>



VSL Justifications – TPL-007-2, R10	
<p>FERC VSL G4 Violation Severity Level Assignment Should Be Based on A Single Violation, Not on A Cumulative Number of Violations</p>	<p>The proposed VSL is not based on a cumulative number of violations.</p>

VRF Justifications – TPL-007-2, R11	
Proposed VRF	Lower
FERC VRF G1 Discussion	Guideline 1- Consistency w/ Blackout Report: N/A
FERC VRF G2 Discussion	Guideline 2- Consistency within a Reliability Standard: The requirement has no sub-requirements so a single VRF was assigned.
FERC VRF G3 Discussion	Guideline 3- Consistency among Reliability Standards. A VRF of Lower is consistent with approved Reliability Standards requiring entities to implement processes to obtain data. These include Reliability Standard MOD-032-1 Requirement R1 and Reliability Standard IRO-010-2 Requirement R1.
FERC VRF G4 Discussion	Guideline 4- Consistency with NERC Definitions of VRFs. The VRF of Lower is consistent with the NERC VRF Definition. Failure to obtain GIC monitor data from at least one GIC monitor located in the system would not be expected to adversely affect the electrical state or capability of the Bulk Electric System, or the ability to effectively monitor, control, or restore the Bulk Electric System.
FERC VRF G5 Discussion	Guideline 5- Treatment of Requirements that Co-mingle More than One Obligation. This requirement does not co-mingle a higher-risk reliability objective with a lesser- risk reliability objective.

Proposed VSLs – TPL-007-2, R11			
Lower	Moderate	High	Severe
N/A	N/A	N/A	The responsible entity did not implement a process to obtain GIC monitor data from at least one GIC monitor located in the Planning Coordinator’s planning area or other part of the system included in the Planning Coordinator’s GIC System Model.

VSL Justifications – TPL-007-2, R11	
NERC VSL Guidelines	Consistent with NERC's VSL Guidelines. The requirement does not have elements or quantities to evaluate degrees of compliance. A VSL of Severe is assigned for non-compliance.
FERC VSL G1 Violation Severity Level Assignments Should Not Have the Unintended Consequence of Lowering the Current Level of Compliance	There is no prior compliance obligation for this requirement.

VSL Justifications – TPL-007-2, R11	
<p>FERC VSL G2 Violation Severity Level Assignments Should Ensure Uniformity and Consistency in the Determination of Penalties Guideline 2a: The Single Violation Severity Level Assignment Category for "Binary" Requirements Is Not Consistent Guideline 2b: Violation Severity Level Assignments that Contain Ambiguous Language</p>	<p>The proposed VSL is written to ensure uniformity and consistency in the determination of penalties.</p> <p>Guideline 2a: The proposed VSL is binary and assigned a Severe VSL.</p> <p>Guideline 2b: The proposed VSL does not use ambiguous terms, supporting uniformity and consistency in the determination of similar penalties for similar violations.</p>
<p>FERC VSL G3 Violation Severity Level Assignment Should Be Consistent with the Corresponding Requirement</p>	<p>The proposed VSL is worded consistently with the corresponding requirement.</p>
<p>FERC VSL G4 Violation Severity Level Assignment Should Be Based on A Single Violation, Not on A Cumulative Number of Violations</p>	<p>The proposed VSL is not based on a cumulative number of violations.</p>

<b>VRF Justifications – TPL-007-2, R12</b>	
<b>Proposed VRF</b>	<b>Lower</b>
FERC VRF G1 Discussion	Guideline 1- Consistency w/ Blackout Report: N/A
FERC VRF G2 Discussion	Guideline 2- Consistency within a Reliability Standard: The requirement has no sub-requirements so a single VRF was assigned.
FERC VRF G3 Discussion	Guideline 3- Consistency among Reliability Standards. A VRF of Lower is consistent with approved Reliability Standards requiring entities to implement processes to obtain data. These include Reliability Standard MOD-032-1 Requirement R1 and Reliability Standard IRO-010-2 Requirement R1.
FERC VRF G4 Discussion	Guideline 4- Consistency with NERC Definitions of VRFs. The VRF of Lower is consistent with the NERC VRF Definition. Failure to obtain geomagnetic field data for the planning area would not be expected to adversely affect the electrical state or capability of the Bulk Electric System, or the ability to effectively monitor, control, or restore the Bulk Electric System.
FERC VRF G5 Discussion	Guideline 5- Treatment of Requirements that Co-mingle More than One Obligation. This requirement does not co-mingle a higher-risk reliability objective with a lesser- risk reliability objective.

Proposed VSLs – TPL-007-2, R12			
Lower	Moderate	High	Severe
N/A	N/A	N/A	The responsible entity did not implement a process to obtain geomagnetic field data for its Planning Coordinator’s planning area.

VSL Justifications – TPL-007-2, R12	
NERC VSL Guidelines	Consistent with NERC's VSL Guidelines. The requirement does not have elements or quantities to evaluate degrees of compliance. A VSL of Severe is assigned for non-compliance.
FERC VSL G1 Violation Severity Level Assignments Should Not Have the Unintended Consequence of Lowering the Current Level of Compliance	There is no prior compliance obligation for this requirement.
FERC VSL G2 Violation Severity Level Assignments Should Ensure Uniformity and Consistency in the Determination of Penalties Guideline 2a: The Single Violation Severity Level	The proposed VSL is written to ensure uniformity and consistency in the determination of penalties.  Guideline 2a: The proposed VSL is binary and assigned a Severe VSL.

## VSL Justifications – TPL-007-2, R12

<p>Assignment Category for "Binary" Requirements Is Not Consistent</p> <p>Guideline 2b: Violation Severity Level Assignments that Contain Ambiguous Language</p>	<p>Guideline 2b: The proposed VSL does not use ambiguous terms, supporting uniformity and consistency in the determination of similar penalties for similar violations.</p>
<p>FERC VSL G3</p> <p>Violation Severity Level Assignment Should Be Consistent with the Corresponding Requirement</p>	<p>The proposed VSL is worded consistently with the corresponding requirement.</p>
<p>FERC VSL G4</p> <p>Violation Severity Level Assignment Should Be Based on A Single Violation, Not on A Cumulative Number of Violations</p>	<p>The proposed VSL is not based on a cumulative number of violations.</p>

# Violation Risk Factor and Violation Severity Level Justifications

## TPL-007-2 – Transmission System Planned Performance for Geomagnetic Disturbance Events

This document provides the Standard Drafting Team's (SDT) justification for assignment of Violation Risk Factors (VRFs) and Violation Severity Levels (VSLs) for each requirement in TPL-007-2 – Transmission System Planned Performance for Geomagnetic Disturbance Events. Each requirement is assigned a VRF and a VSL. These elements support the determination of an initial value range for the Base Penalty Amount regarding violations of requirements in FERC-approved Reliability Standards, as defined in the ERO Sanction Guidelines. The SDT applied the following NERC criteria and FERC Guidelines when proposing VRFs and VSLs for the requirements under this project.

### NERC Criteria - Violation Risk Factors

#### High Risk Requirement

A requirement that, if violated, could directly cause or contribute to Bulk Electric System instability, separation, or a cascading sequence of failures, or could place the Bulk Electric System at an unacceptable risk of instability, separation, or cascading failures; or, a requirement in a planning time frame that, if violated, could, under emergency, abnormal, or restorative conditions anticipated by the preparations, directly cause or contribute to Bulk Electric System instability, separation, or a cascading sequence of failures, or could place the Bulk Electric System at an unacceptable risk of instability, separation, or cascading failures, or could hinder restoration to a normal condition.

#### Medium Risk Requirement

A requirement that, if violated, could directly affect the electrical state or the capability of the Bulk Electric System, or the ability to effectively monitor and control the Bulk Electric System. However, violation of a medium risk requirement is unlikely to lead to Bulk Electric System instability, separation, or cascading failures; or, a requirement in a planning time frame that, if violated, could, under emergency, abnormal, or restorative conditions anticipated by the preparations, directly and adversely affect the electrical state or capability of the Bulk Electric System, or the ability to effectively monitor, control, or restore the Bulk Electric System. However, violation of a medium risk requirement is unlikely, under emergency, abnormal, or restoration conditions anticipated by the preparations, to lead to Bulk Electric System instability, separation, or cascading failures, nor to hinder restoration to a normal condition.

### Lower Risk Requirement

A requirement that is administrative in nature and a requirement that, if violated, would not be expected to adversely affect the electrical state or capability of the Bulk Electric System, or the ability to effectively monitor and control the Bulk Electric System; or, a requirement that is administrative in nature and a requirement in a planning time frame that, if violated, would not, under the emergency, abnormal, or restorative conditions anticipated by the preparations, be expected to adversely affect the electrical state or capability of the Bulk Electric System, or the ability to effectively monitor, control, or restore the Bulk Electric System.

## FERC Violation Risk Factor Guidelines

### Guideline (1) – Consistency with the Conclusions of the Final Blackout Report

The Commission seeks to ensure that VRFs assigned to Requirements of Reliability Standards in these identified areas appropriately reflect their historical critical impact on the reliability of the Bulk-Power System. In the VSL Order, FERC listed critical areas (from the Final Blackout Report) where violations could severely affect the reliability of the Bulk-Power System:

- Emergency operations
- Vegetation management
- Operator personnel training
- Protection systems and their coordination
- Operating tools and backup facilities
- Reactive power and voltage control
- System modeling and data exchange
- Communication protocol and facilities
- Requirements to determine equipment ratings
- Synchronized data recorders



- Clearer criteria for operationally critical facilities
- Appropriate use of transmission loading relief.

**Guideline (2) – Consistency within a Reliability Standard**

The Commission expects a rational connection between the sub-Requirement VRF assignments and the main Requirement VRF assignment.

**Guideline (3) – Consistency among Reliability Standards**

The Commission expects the assignment of VRFs corresponding to requirements that address similar reliability goals in different Reliability Standards would be treated comparably.

**Guideline (4) – Consistency with NERC’s Definition of the Violation Risk Factor Level**

Guideline (4) was developed to evaluate whether the assignment of a particular VRF level conforms to NERC’s definition of that risk level.

**Guideline (5) – Treatment of Requirements that Co-mingle More Than One Obligation**

Where a single Requirement co-mingles a higher risk reliability objective and a lesser risk reliability objective, the VRF assignment for such requirements must not be watered down to reflect the lower risk level associated with the less important objective of the Reliability Standard.

**NERC Criteria - Violation Severity Levels**

VSLs define the degree to which compliance with a requirement was not achieved. Each requirement must have at least one VSL. While it is preferable to have four VSLs for each requirement, some requirements do not have multiple “degrees” of noncompliant performance and may have only one, two, or three VSLs.

VSLs should be based on NERC’s overarching criteria shown in the table below:

Lower VSL	Moderate VSL	High VSL	Severe VSL
The performance or product measured almost meets the full intent of the requirement.	The performance or product measured meets the majority of the intent of the requirement.	The performance or product measured does not meet the majority of the intent of the requirement, but does meet some of the intent.	The performance or product measured does not substantively meet the intent of the requirement.

### FERC Order of Violation Severity Levels

FERC’s VSL guidelines are presented below, followed by an analysis of whether the VSLs proposed for each requirement in the standard meet the FERC Guidelines for assessing VSLs:

#### Guideline 1 – Violation Severity Level Assignments Should Not Have the Unintended Consequence of Lowering the Current Level of Compliance

Compare the VSLs to any prior levels of non-compliance and avoid significant changes that may encourage a lower level of compliance than was required when levels of non-compliance were used.

#### Guideline 2 – Violation Severity Level Assignments Should Ensure Uniformity and Consistency in the Determination of Penalties

A violation of a “binary” type requirement must be a “Severe” VSL.

Do not use ambiguous terms such as “minor” and “significant” to describe noncompliant performance.

#### Guideline 3 – Violation Severity Level Assignment Should Be Consistent with the Corresponding Requirement

VSLs should not expand on what is required in the requirement.

**Guideline 4 – Violation Severity Level Assignment Should Be Based on A Single Violation, Not on A Cumulative Number of Violations**

Unless otherwise stated in the requirement, each instance of non-compliance with a requirement is a separate violation. Section 4 of the Sanction Guidelines states that assessing penalties on a per-violation per-day basis is the “default” for penalty calculations.

VRF Justifications – TPL-007-2, R1	
Proposed VRF	Low
FERC VRF G1 Discussion	Guideline 1- Consistency w/ Blackout Report. N/A
FERC VRF G2 Discussion	Guideline 2- Consistency within a Reliability Standard. The requirement has no sub-requirements so a single VRF was assigned.
FERC VRF G3 Discussion	Guideline 3- Consistency among Reliability Standards. A VRF of Lower is consistent with Reliability Standard TPL-001-4 Requirement R7, which requires the Planning Coordinator, in conjunction with each of its Transmission Planners, to identify each entity’s individual and joint responsibilities for performing required studies for the Planning Assessment. Proposed TPL-007-2 Requirement R1 requires Planning Coordinators, in conjunction with Transmission Planners, to identify individual and joint responsibilities for maintaining models and performing studies needed to complete the benchmark and supplemental GMD Vulnerability Assessments, and implementing process(es) to obtain GMD measurement data as specified in the Standard.
FERC VRF G4 Discussion	Guideline 4- Consistency with NERC Definitions of VRFs. A VRF of Lower is consistent with the NERC VRF definition. The requirement for identifying individual and joint responsibilities of the Planning Coordinator and each of the Transmission Planners in the Planning Coordinator’s planning area for maintaining models, performing GMD studies, and obtaining GMD measurement data, if violated, would not be expected to adversely affect the electrical state or capability of the Bulk Electric System, or the ability to effectively monitor, control, or restore the Bulk Electric System under conditions of a GMD event.

VRF Justifications – TPL-007-2, R1	
Proposed VRF	Low
FERC VRF G5 Discussion	Guideline 5- Treatment of Requirements that Co-mingle More than One Obligation. The requirement contains one objective, therefore a single VRF is assigned.

Proposed VSLs – TPL-007-2, R1			
Lower	Moderate	High	Severe
N/A	N/A	N/A	The Planning Coordinator, in conjunction with its Transmission Planner(s), failed to determine and identify individual or joint responsibilities of the Planning Coordinator and Transmission Planner(s) in the Planning Coordinator’s planning area for maintaining models, performing the study or studies needed to complete benchmark and supplemental GMD Vulnerability Assessments, and implementing process(es) to obtain GMD measurement data as specified in <del>the Standard</del> -this standard.

VSL Justifications – TPL-007-2, R1	
NERC VSL Guidelines	Consistent with NERC's VSL Guidelines. The requirement does not have elements or quantities to evaluate degrees of compliance. A VSL of Severe is assigned for non-compliance.
FERC VSL G1 Violation Severity Level Assignments Should Not Have the Unintended Consequence of Lowering the Current Level of Compliance	The VSL is not changed in TPL-007-2.
FERC VSL G2 Violation Severity Level Assignments Should Ensure Uniformity and Consistency in the Determination of Penalties Guideline 2a: The Single Violation Severity Level Assignment Category for "Binary" Requirements Is Not Consistent Guideline 2b: Violation Severity Level Assignments that Contain Ambiguous Language	The proposed VSL is written to ensure uniformity and consistency in the determination of penalties.  Guideline 2a: The proposed VSL is binary and assigned a Severe VSL.  Guideline 2b: The proposed VSL does not use ambiguous terms, supporting uniformity and consistency in the determination of similar penalties for similar violations.
FERC VSL G3 Violation Severity Level Assignment Should Be	The proposed VSL is worded consistently with the corresponding requirement.

Consistent with the Corresponding Requirement	
FERC VSL G4 Violation Severity Level Assignment Should Be Based on A Single Violation, Not on A Cumulative Number of Violations	The proposed VSL is not based on a cumulative number of violations.

VRF Justifications – TPL-007-2, R2	
Proposed VRF	High
FERC VRF G1 Discussion	Guideline 1- Consistency w/ Blackout Report: N/A
FERC VRF G2 Discussion	Guideline 2- Consistency within a Reliability Standard: The requirement has no sub-requirements so a single VRF was assigned.
FERC VRF G3 Discussion	Guideline 3- Consistency among Reliability Standards. A VRF of High is consistent with the VRF for Reliability Standard TPL-001-4 Requirement R1 as amended in NERC's filing dated August 29, 2014, which requires Transmission Planners and Planning Coordinators to maintain models within its respective planning area for performing studies needed to complete its Planning Assessment. Proposed TPL-007-2, Requirement R2 requires responsible entities to maintain System models and GIC System models of the responsible entity's planning area for performing the studies needed to complete benchmark and supplemental GMD Vulnerability Assessments.
FERC VRF G4 Discussion	Guideline 4- Consistency with NERC Definitions of VRFs. The VRF of High is consistent with the NERC VRF Definition. The System Models and GIC System Models serve as the foundation for all conditions and events that are required to be studied and evaluated in the benchmark and supplemental GMD Vulnerability Assessments. For this reason, failure to maintain models of the responsible entity's planning area for performing GMD studies could, under GMD conditions that are as severe as the benchmark and supplemental GMD event, place the Bulk Electric System at an unacceptable risk of instability, separation, or cascading failures.
FERC VRF G5 Discussion	Guideline 5- Treatment of Requirements that Co-mingle More than One Obligation. This requirement does not co-mingle a higher-risk reliability objective with a lesser- risk reliability objective.



Proposed VSLs – TPL-007-2, R2			
Lower	Moderate	High	Severe
N/A	N/A	The responsible entity did not maintain either System models or GIC System models of the responsible entity’s planning area for performing the <del>study or studies</del> needed to complete benchmark and supplemental GMD Vulnerability Assessments.	The responsible entity did not maintain both System models and GIC System models of the responsible entity’s planning area for performing the <del>study or studies</del> needed to complete benchmark and supplemental GMD Vulnerability Assessments.

VSL Justifications – TPL-007-2, R2	
NERC VSL Guidelines	Consistent with NERC's VSL Guidelines. The requirement may be described by elements or quantities to evaluate degrees of compliance. Two VSLs are specified for a graduated scale.
FERC VSL G1 Violation Severity Level Assignments Should Not Have the Unintended Consequence of Lowering the Current Level of Compliance	The VSL is not changed in TPL-007-2.

VSL Justifications – TPL-007-2, R2	
<p>FERC VSL G2 Violation Severity Level Assignments Should Ensure Uniformity and Consistency in the Determination of Penalties Guideline 2a: The Single Violation Severity Level Assignment Category for "Binary" Requirements Is Not Consistent Guideline 2b: Violation Severity Level Assignments that Contain Ambiguous Language</p>	<p>The proposed VSL is written to ensure uniformity and consistency in the determination of penalties.</p> <p>Guideline 2a: The proposed VSL is not binary.</p> <p>Guideline 2b: The proposed VSL does not use ambiguous terms, supporting uniformity and consistency in the determination of similar penalties for similar violations.</p>
<p>FERC VSL G3 Violation Severity Level Assignment Should Be Consistent with the Corresponding Requirement</p>	<p>The proposed VSL is worded consistently with the corresponding requirement.</p>
<p>FERC VSL G4 Violation Severity Level Assignment Should Be Based on A Single Violation, Not on A Cumulative Number of Violations</p>	<p>The proposed VSL is not based on a cumulative number of violations.</p>

VRF Justifications – TPL-007-2, R3	
Proposed VRF	Medium
FERC VRF G1 Discussion	Guideline 1- Consistency w/ Blackout Report: N/A
FERC VRF G2 Discussion	Guideline 2- Consistency within a Reliability Standard: The requirement has no sub-requirements so a single VRF was assigned.
FERC VRF G3 Discussion	Guideline 3- Consistency among Reliability Standards. A VRF of Medium is consistent with Reliability Standard TPL-001-4 Requirement R5 which requires Transmission Planners and Planning Coordinators to have criteria for acceptable System steady state voltage limits. Proposed TPL-007-2 Requirement R4 requires responsible entities to have criteria for acceptable System steady state voltage performance for its System during the benchmark GMD event; these criteria may be different from the voltage limits determined in Reliability Standard TPL-001-4 Requirement R5.
FERC VRF G4 Discussion	Guideline 4- Consistency with NERC Definitions of VRFs. The VRF of Medium is consistent with the NERC VRF Definition. Failure to have criteria for acceptable System steady state voltage limits for its System during a GMD planning event could directly and adversely affect the electrical state or capability of the Bulk Electric System, or the ability to effectively monitor, control, or restore the Bulk Electric System during an actual GMD event. However, it is unlikely that such a failure by itself would lead to Bulk Electric System instability, separation, or cascading.
FERC VRF G5 Discussion	Guideline 5- Treatment of Requirements that Co-mingle More than One Obligation. This requirement does not co-mingle a higher-risk reliability objective with a lesser- risk reliability objective.

Proposed VSLs – TPL-007-2, R3			
Lower	Moderate	High	Severe
N/A	N/A	N/A	The responsible entity did not have criteria for acceptable System steady state voltage performance for its System during the GMD events described in Attachment 1 as required.

VSL Justifications – TPL-007-2, R3	
NERC VSL Guidelines	Consistent with NERC's VSL Guidelines. The requirement does not have elements or quantities to evaluate degrees of compliance. A VSL of Severe is assigned for non-compliance.
FERC VSL G1 Violation Severity Level Assignments Should Not Have the Unintended Consequence of Lowering the Current Level of Compliance	The VSL is not changed in TPL-007-2.

VSL Justifications – TPL-007-2, R3	
<p>FERC VSL G2 Violation Severity Level Assignments Should Ensure Uniformity and Consistency in the Determination of Penalties Guideline 2a: The Single Violation Severity Level Assignment Category for "Binary" Requirements Is Not Consistent Guideline 2b: Violation Severity Level Assignments that Contain Ambiguous Language</p>	<p>The proposed VSL is written to ensure uniformity and consistency in the determination of penalties.</p> <p>Guideline 2a: The proposed VSL is binary and assigned a Severe VSL.</p> <p>Guideline 2b: The proposed VSL does not use ambiguous terms, supporting uniformity and consistency in the determination of similar penalties for similar violations.</p>
<p>FERC VSL G3 Violation Severity Level Assignment Should Be Consistent with the Corresponding Requirement</p>	<p>The proposed VSL is worded consistently with the corresponding requirement.</p>
<p>FERC VSL G4 Violation Severity Level Assignment Should Be Based on A Single Violation, Not on A Cumulative Number of Violations</p>	<p>The proposed VSL is not based on a cumulative number of violations.</p>

VRF Justifications – TPL-007-2, R4	
Proposed VRF	High
FERC VRF G1 Discussion	Guideline 1- Consistency w/ Blackout Report: N/A
FERC VRF G2 Discussion	Guideline 2- Consistency within a Reliability Standard: The requirement has no sub-requirements so a single VRF was assigned.
FERC VRF G3 Discussion	Guideline 3- Consistency among Reliability Standards. A VRF of High is consistent with Reliability Standard TPL-001-4 Requirement R2 which requires Transmission Planners and Planning Coordinators to prepare an annual Planning Assessment to ensure its portion of the Bulk Electric System meets performance criteria. Proposed TPL-007-2 Requirement R4 requires responsible entities to complete a benchmark GMD Vulnerability Assessment to ensure the system meets performance criteria during the benchmark GMD event.
FERC VRF G4 Discussion	Guideline 4- Consistency with NERC Definitions of VRFs. The VRF of High is consistent with the NERC VRF Definition. Failure to complete a benchmark GMD Vulnerability Assessment could, under GMD conditions that are as severe as the benchmark GMD event, place the Bulk Electric System at an unacceptable risk of instability, separation, or cascading failures.
FERC VRF G5 Discussion	Guideline 5- Treatment of Requirements that Co-mingle More than One Obligation. This requirement does not co-mingle a higher-risk reliability objective with a lesser- risk reliability objective.

Proposed VSLs – TPL-007-2, R4			
Lower	Moderate	High	Severe
<p>The responsible entity completed a benchmark GMD Vulnerability Assessment, but it was more than 60 calendar months and less than or equal to 64 calendar months since the last benchmark GMD Vulnerability Assessment.</p>	<p>The responsible entity's completed benchmark GMD Vulnerability Assessment failed to satisfy one of <u>the</u> elements listed in Requirement R4, Parts 4.1 through 4.3;</p> <p>OR</p> <p>The responsible entity completed a benchmark GMD Vulnerability Assessment, but it was more than 64 calendar months and less than or equal to 68 calendar months since the last benchmark GMD Vulnerability Assessment.</p>	<p>The responsible entity's completed benchmark GMD Vulnerability Assessment failed to satisfy two of the elements listed in Requirement R4, Parts 4.1 through 4.3;</p> <p>OR</p> <p>The responsible entity completed a benchmark GMD Vulnerability Assessment, but it was more than 68 calendar months and less than or equal to 72 calendar months since the last benchmark GMD Vulnerability Assessment.</p>	<p>The responsible entity's completed benchmark GMD Vulnerability Assessment failed to satisfy three of the elements listed in Requirement R4, Parts 4.1 through 4.3;</p> <p>OR</p> <p>The responsible entity completed a benchmark GMD Vulnerability Assessment, but it was more than 72 calendar months since the last benchmark GMD Vulnerability Assessment;</p> <p>OR</p> <p>The responsible entity does not have a completed benchmark GMD Vulnerability Assessment.</p>

VSL Justifications – TPL-007-2, R4	
NERC VSL Guidelines	Consistent with NERC's VSL Guidelines. The requirement may be described by elements or quantities to evaluate degrees of compliance. Four VSLs are specified for a graduated scale.
FERC VSL G1 Violation Severity Level Assignments Should Not Have the Unintended Consequence of Lowering the Current Level of Compliance	The VSL is not changed in TPL-007-2.
FERC VSL G2 Violation Severity Level Assignments Should Ensure Uniformity and Consistency in the Determination of Penalties Guideline 2a: The Single Violation Severity Level Assignment Category for "Binary" Requirements Is Not Consistent Guideline 2b: Violation Severity Level Assignments that Contain Ambiguous Language	<p>The proposed VSL is written to ensure uniformity and consistency in the determination of penalties.</p> <p>Guideline 2a: The proposed VSL is not binary.</p> <p>Guideline 2b: The proposed VSL does not use ambiguous terms, supporting uniformity and consistency in the determination of similar penalties for similar violations.</p>



VSL Justifications – TPL-007-2, R4	
FERC VSL G3 Violation Severity Level Assignment Should Be Consistent with the Corresponding Requirement	The proposed VSL is worded consistently with the corresponding requirement.
FERC VSL G4 Violation Severity Level Assignment Should Be Based on A Single Violation, Not on A Cumulative Number of Violations	The proposed VSL is not based on a cumulative number of violations.

VRF Justifications – TPL-007-2, R5	
<b>Proposed VRF</b>	<b>Medium</b>
FERC VRF G1 Discussion	Guideline 1- Consistency w/ Blackout Report: N/A
FERC VRF G2 Discussion	Guideline 2- Consistency within a Reliability Standard: The requirement has no sub-requirements so a single VRF was assigned.

VRF Justifications – TPL-007-2, R5	
Proposed VRF	Medium
FERC VRF G3 Discussion	Guideline 3- Consistency among Reliability Standards. A VRF of Medium is consistent with Reliability Standard MOD-032-1 Requirement R2 which requires applicable entities to provide modeling data to Transmission Planners and Planning Coordinators. A VRF of Medium is also consistent with Reliability Standard IRO-010-2 Requirement R3 which requires entities to provide data necessary for the Reliability Coordinator to perform its Operational Planning Analysis and Real-time Assessments. Proposed TPL-007-2 Requirement R5 requires responsible entities to provide specific geomagnetically-induced currents (GIC) flow information to Transmission Owners and Generator Owners for performing transformer thermal impact assessments.
FERC VRF G4 Discussion	Guideline 4- Consistency with NERC Definitions of VRFs. The VRF of Medium is consistent with the NERC VRF Definition. Failure to provide GIC flow information for the benchmark GMD event could directly and adversely affect the electrical state or capability of the Bulk Electric System, or the ability to effectively monitor, control, or restore the Bulk Electric System during a GMD event. However, it is unlikely that such a failure by itself would lead to Bulk Electric System instability, separation, or cascading.
FERC VRF G5 Discussion	Guideline 5- Treatment of Requirements that Co-mingle More than One Obligation. This requirement does not co-mingle a higher-risk reliability objective with a lesser- risk reliability objective.

Proposed VSLs – TPL-007-2, R5			
Lower	Moderate	High	Severe
The responsible entity provided the effective GIC time series, GIC(t), in response to written request, but did so more than 90 calendar days and less than or equal to 100 calendar days after receipt of a written request.	The responsible entity provided the effective GIC time series, GIC(t), in response to written request, but did so more than 100 calendar days and less than or equal to 110 calendar days after receipt of a written request.	The responsible entity provided the effective GIC time series, GIC(t), in response to written request, but did so more than 110 calendar days after receipt of a written request.	The responsible entity did not provide the maximum effective GIC value to the Transmission Owner and Generator Owner that owns each applicable BES power transformer in the planning area; OR The responsible entity did not provide the effective GIC time series, GIC(t), upon written request.

VSL Justifications – TPL-007-2, R5	
NERC VSL Guidelines	Consistent with NERC's VSL Guidelines. The requirement may be described by elements or quantities to evaluate degrees of compliance. Four VSLs are specified for a graduated scale.
FERC VSL G1 Violation Severity Level Assignments Should Not Have the Unintended Consequence of Lowering the Current Level of Compliance	The VLS is not changed in TPL-007-2.

VSL Justifications – TPL-007-2, R5	
<p>FERC VSL G2 Violation Severity Level Assignments Should Ensure Uniformity and Consistency in the Determination of Penalties Guideline 2a: The Single Violation Severity Level Assignment Category for "Binary" Requirements Is Not Consistent Guideline 2b: Violation Severity Level Assignments that Contain Ambiguous Language</p>	<p>The proposed VSL is written to ensure uniformity and consistency in the determination of penalties.</p> <p>Guideline 2a: The proposed VSL is not binary.</p> <p>Guideline 2b: The proposed VSL does not use ambiguous terms, supporting uniformity and consistency in the determination of similar penalties for similar violations.</p>
<p>FERC VSL G3 Violation Severity Level Assignment Should Be Consistent with the Corresponding Requirement</p>	<p>The proposed VSL is worded consistently with the corresponding requirement.</p>
<p>FERC VSL G4 Violation Severity Level Assignment Should Be Based on A Single Violation, Not on A Cumulative Number of Violations</p>	<p>The proposed VSL is not based on a cumulative number of violations.</p>

VRF Justifications – TPL-007-2, R6	
Proposed VRF	Medium
FERC VRF G1 Discussion	Guideline 1- Consistency w/ Blackout Report: N/A
FERC VRF G2 Discussion	Guideline 2- Consistency within a Reliability Standard: The requirement has no sub-requirements so a single VRF was assigned.
FERC VRF G3 Discussion	Guideline 3- Consistency among Reliability Standards. A VRF of Medium is consistent with Reliability Standard FAC-008-3 Requirement R6 which requires Transmission Owners and Generator Owners to have Facility Ratings for all solely and jointly owned Facilities that are consistent with the associated Facility Ratings methodology or documentation. Proposed TPL-007-2 Requirement R6 requires responsible entities to conduct a benchmark thermal impact assessment for solely and jointly owned applicable transformers and provide results including suggested actions to mitigate identified impacts to planning entities.
FERC VRF G4 Discussion	Guideline 4- Consistency with NERC Definitions of VRFs. The VRF of Medium is consistent with the NERC VRF Definition. Failure to conduct a benchmark transformer thermal impact assessment could directly and adversely affect the electrical state or capability of the Bulk Electric System, or the ability to effectively monitor, control, or restore the Bulk Electric System during a GMD event. However, it is unlikely that such a failure by itself would lead to Bulk Electric System instability, separation, or cascading.
FERC VRF G5 Discussion	Guideline 5- Treatment of Requirements that Co-mingle More than One Obligation. This requirement does not co-mingle a higher-risk reliability objective with a lesser- risk reliability objective.

Proposed VSLs – TPL-007-2, R6			
Lower	Moderate	High	Severe
<p>The responsible entity failed to conduct a benchmark thermal impact assessment for 5% or less or one of its solely owned and jointly owned applicable BES power transformers (whichever is greater) where the maximum effective GIC value provided in Requirement R5, Part 5.1, is 75 A or greater per phase;</p> <p>OR</p> <p>The responsible entity conducted a benchmark thermal impact assessment for its solely owned and jointly owned applicable BES power transformers where the maximum effective GIC value provided in Requirement R5, Part 5.1, is 75 A or greater per phase but did so more than 24 calendar months and less than or equal to 26 calendar months</p>	<p>The responsible entity failed to conduct a benchmark thermal impact assessment for more than 5% up to (and including) 10% or two of its solely owned and jointly owned applicable BES power transformers (whichever is greater) where the maximum effective GIC value provided in Requirement R5, Part 5.1, is 75 A or greater per phase;</p> <p>OR</p> <p>The responsible entity conducted a benchmark thermal impact assessment for its solely owned and jointly owned applicable BES power transformers where the maximum effective GIC value provided in Requirement R5, Part 5.1, is 75 A or greater per phase but did so more than 26 calendar months and less than</p>	<p>The responsible entity failed to conduct a benchmark thermal impact assessment for more than 10% up to (and including) 15% or three of its solely owned and jointly owned applicable BES power transformers (whichever is greater) where the maximum effective GIC value provided in Requirement R5, Part 5.1, is 75 A or greater per phase;</p> <p>OR</p> <p>The responsible entity conducted a benchmark thermal impact assessment for its solely owned and jointly owned applicable BES power transformers where the maximum effective GIC value provided in Requirement R5, Part 5.1, is 75 A or greater per phase but did so more than 28 calendar months and less than</p>	<p>The responsible entity failed to conduct a benchmark thermal impact assessment for more than 15% or more than three of its solely owned and jointly owned applicable BES power transformers (whichever is greater) where the maximum effective GIC value provided in Requirement R5, Part 5.1, is 75 A or greater per phase;</p> <p>OR</p> <p>The responsible entity conducted a benchmark thermal impact assessment for its solely owned and jointly owned applicable BES power transformers where the maximum effective GIC value provided in Requirement R5, Part 5.1, is 75 A or greater per phase but did so more than 30 calendar months of receiving</p>

Proposed VSLs – TPL-007-2, R6			
Lower	Moderate	High	Severe
of receiving GIC flow information specified in Requirement R5, Part 5.1.	or equal to 28 calendar months of receiving GIC flow information specified in Requirement R5, Part 5.1; OR The responsible entity failed to include one of the required elements as listed in Requirement R6, Parts 6.1 through 6.3.	or equal to 30 calendar months of receiving GIC flow information specified in Requirement R5, Part 5.1; OR The responsible entity failed to include two of the required elements as listed in Requirement R6, Parts 6.1 through 6.3.	GIC flow information specified in Requirement R5, Part 5.1; OR The responsible entity failed to include three of the required elements as listed in Requirement R6, Parts 6.1 through 6.3.

VSL Justifications – TPL-007-2, R6	
NERC VSL Guidelines	Consistent with NERC's VSL Guidelines. The requirement may be described by elements or quantities to evaluate degrees of compliance. Four VSLs are specified for a graduated scale.
FERC VSL G1 Violation Severity Level Assignments Should Not Have the Unintended Consequence of Lowering the Current Level of Compliance	The VSL is not changed in TPL-007-2.

VSL Justifications – TPL-007-2, R6	
<p>FERC VSL G2 Violation Severity Level Assignments Should Ensure Uniformity and Consistency in the Determination of Penalties Guideline 2a: The Single Violation Severity Level Assignment Category for "Binary" Requirements Is Not Consistent Guideline 2b: Violation Severity Level Assignments that Contain Ambiguous Language</p>	<p>The proposed VSL is written to ensure uniformity and consistency in the determination of penalties.</p> <p>Guideline 2a: The proposed VSL is not binary.</p> <p>Guideline 2b: The proposed VSL does not use ambiguous terms, supporting uniformity and consistency in the determination of similar penalties for similar violations.</p>
<p>FERC VSL G3 Violation Severity Level Assignment Should Be Consistent with the Corresponding Requirement</p>	<p>The proposed VSL is worded consistently with the corresponding requirement.</p>
<p>FERC VSL G4 Violation Severity Level Assignment Should Be Based on A Single Violation, Not on A Cumulative Number of Violations</p>	<p>The proposed VSL is not based on a cumulative number of violations.</p>



VRF Justifications – TPL-007-2, R7	
Proposed VRF	High
FERC VRF G1 Discussion	Guideline 1- Consistency w/ Blackout Report: N/A
FERC VRF G2 Discussion	Guideline 2- Consistency within a Reliability Standard: The requirement has no sub-requirements so a single VRF was assigned.
FERC VRF G3 Discussion	Guideline 3- Consistency among Reliability Standards. A VRF of High is consistent with Reliability Standard TPL-001-4 Requirement R2 which requires Transmission Planners and Planning Coordinators to include a Corrective Action Plan that addresses identified performance issues in the annual Planning Assessment. Proposed TPL-007-2 Requirement R7 requires responsible entities to develop a Corrective Action Plan when results of the benchmark GMD Vulnerability Assessment indicate that the System does not meet performance requirements. While Reliability Standard TPL-001-4 has a single requirement for performing the Planning Assessment and developing the Corrective Action Plan, proposed TPL-007-2 has split the requirements for performing a benchmark GMD Vulnerability Assessment and developing the Corrective Action Plan into two separate requirements because the transformer thermal impact assessments performed by Transmission Owners and Generator Owners must be considered. The sequencing with separate requirements follows a logical flow of the GMD Vulnerability Assessment process.
FERC VRF G4 Discussion	Guideline 4- Consistency with NERC Definitions of VRFs. The VRF of High is consistent with the NERC VRF Definition. Failure to develop a Corrective Action Plan that addresses issues identified in a GMD Vulnerability Assessment could, under GMD conditions that are as severe as the benchmark GMD event, place the Bulk Electric System at an unacceptable risk of instability, separation, or cascading failures.
FERC VRF G5 Discussion	Guideline 5- Treatment of Requirements that Co-mingle More than One Obligation. This requirement does not co-mingle a higher-risk reliability objective with a lesser- risk reliability objective.

Proposed VSLs – TPL-007-2, R7			
Lower	Moderate	High	Severe
The responsible entity's Corrective Action Plan failed to comply with one of the elements in Requirement R7, Parts 7.1 through 7.5.	The responsible entity's Corrective Action Plan failed to comply with two of the elements in Requirement R7, Parts 7.1 through 7.5.	The responsible entity's Corrective Action Plan failed to comply with three of the elements in Requirement R7, Parts 7.1 through 7.5.	The responsible entity's Corrective Action Plan failed to comply with four or more of the elements in Requirement R7, Parts 7.1 through 7.5; OR The responsible entity did not have a Corrective Action Plan as required by Requirement R7.

VSL Justifications – TPL-007-2, R7	
NERC VSL Guidelines	Consistent with NERC's VSL Guidelines. The requirement may be described by elements or quantities to evaluate degrees of compliance. Four VSLs are specified for a graduated scale.
FERC VSL G1 Violation Severity Level Assignments Should Not Have the Unintended Consequence of Lowering the Current Level of Compliance	The proposed requirement is a significant revision to TPL-007-2 to address the directive for Corrective Action Plan deadlines contained in FERC Order No. 830. There is no prior compliance obligation related to the directive. However, the requirement uses the same construct for a graduated scale as TPL-007-1 Requirement R7 and is similar to Reliability Standard TPL-001-4, Requirement R2.

VSL Justifications – TPL-007-2, R7	
<p>FERC VSL G2 Violation Severity Level Assignments Should Ensure Uniformity and Consistency in the Determination of Penalties Guideline 2a: The Single Violation Severity Level Assignment Category for "Binary" Requirements Is Not Consistent Guideline 2b: Violation Severity Level Assignments that Contain Ambiguous Language</p>	<p>The proposed VSL is written to ensure uniformity and consistency in the determination of penalties.</p> <p>Guideline 2a: The proposed VSL is not binary.</p> <p>Guideline 2b: The proposed VSL does not use ambiguous terms, supporting uniformity and consistency in the determination of similar penalties for similar violations.</p>
<p>FERC VSL G3 Violation Severity Level Assignment Should Be Consistent with the Corresponding Requirement</p>	<p>The proposed VSL is worded consistently with the corresponding requirement.</p>
<p>FERC VSL G4 Violation Severity Level Assignment Should Be Based on A Single Violation, Not on A Cumulative Number of Violations</p>	<p>The proposed VSL is not based on a cumulative number of violations.</p>

VRF Justifications – TPL-007-2, R8	
Proposed VRF	High
FERC VRF G1 Discussion	Guideline 1- Consistency w/ Blackout Report: N/A
FERC VRF G2 Discussion	Guideline 2- Consistency within a Reliability Standard: The requirement has no sub-requirements so a single VRF was assigned.
FERC VRF G3 Discussion	Guideline 3- Consistency among Reliability Standards. A VRF of High is consistent with Reliability Standard TPL-001-4 Requirement R2 which requires Transmission Planners and Planning Coordinators to prepare an annual Planning Assessment to ensure its portion of the Bulk Electric System meets performance criteria. The proposed requirement is also consistent with approved TPL-007-1 Requirement R4 (unchanged in proposed TPL-007-2 Requirement R4). Proposed TPL-007-2 Requirement R8 requires responsible entities to complete a supplemental GMD Vulnerability Assessment to assess system performance during a supplemental GMD event.
FERC VRF G4 Discussion	Guideline 4- Consistency with NERC Definitions of VRFs. The VRF of High is consistent with the NERC VRF Definition. Failure to complete a supplemental GMD Vulnerability Assessment could, under GMD conditions that are as severe as the supplemental GMD event, place the Bulk Electric System at an unacceptable risk of instability, separation, or cascading failures by precluding responsible entities from considering actions to mitigate risk of Cascading.
FERC VRF G5 Discussion	Guideline 5- Treatment of Requirements that Co-mingle More than One Obligation. This requirement does not co-mingle a higher-risk reliability objective with a lesser- risk reliability objective.

Proposed VSLs – TPL-007-2, R8			
Lower	Moderate	High	Severe
<p><u>The responsible entity's completed supplemental GMD Vulnerability Assessment failed to satisfy one of elements listed in Requirement R8, Parts 8.1 through 8.4;</u></p> <p>OR</p> <p>The responsible entity completed a supplemental GMD Vulnerability Assessment, but it was more than 60 calendar months and less than or equal to 64 calendar months since the last supplemental GMD Vulnerability Assessment;</p> <p>OR</p> <p><del>The responsible entity's completed supplemental GMD Vulnerability Assessment failed to satisfy one of elements listed in Requirement R8, Parts 8.1 through 8.4;</del></p>	<p>The responsible entity's completed supplemental GMD Vulnerability Assessment failed to satisfy two of elements listed in Requirement R8, Parts 8.1 through 8.4;</p> <p>OR</p> <p>The responsible entity completed a supplemental GMD Vulnerability Assessment, but it was more than 64 calendar months and less than or equal to 68 calendar months since the last supplemental GMD Vulnerability Assessment.</p>	<p>The responsible entity's completed supplemental GMD Vulnerability Assessment failed to satisfy three of the elements listed in Requirement R8, Parts 8.1 through 8.4;</p> <p>OR</p> <p>The responsible entity completed a supplemental GMD Vulnerability Assessment, but it was more than 68 calendar months and less than or equal to 72 calendar months since the last supplemental GMD Vulnerability Assessment.</p>	<p>The responsible entity's completed supplemental GMD Vulnerability Assessment failed to satisfy four of the elements listed in Requirement R8, Parts 8.1 through 8.4;</p> <p>OR</p> <p>The responsible entity completed a supplemental GMD Vulnerability Assessment, but it was more than 72 calendar months since the last supplemental GMD Vulnerability Assessment;</p> <p>OR</p> <p>The responsible entity does not have a completed supplemental GMD Vulnerability Assessment.</p>

VSL Justifications – TPL-007-2, R8	
NERC VSL Guidelines	Consistent with NERC's VSL Guidelines. The requirement may be described by elements or quantities to evaluate degrees of compliance. Four VSLs are specified for a graduated scale.
FERC VSL G1 Violation Severity Level Assignments Should Not Have the Unintended Consequence of Lowering the Current Level of Compliance	There is no prior compliance obligation related to supplemental GMD Vulnerability Assessment. However, the requirement is similar to approved TPL-007-1, Requirement R4 (unchanged in proposed TPL-007-2 Requirement R4). That requirement also has a graduated scale for VSLs.
FERC VSL G2 Violation Severity Level Assignments Should Ensure Uniformity and Consistency in the Determination of Penalties Guideline 2a: The Single Violation Severity Level Assignment Category for "Binary" Requirements Is Not Consistent Guideline 2b: Violation Severity Level Assignments that Contain Ambiguous Language	<p>The proposed VSL is written to ensure uniformity and consistency in the determination of penalties.</p> <p>Guideline 2a: The proposed VSL is not binary.</p> <p>Guideline 2b: The proposed VSL does not use ambiguous terms, supporting uniformity and consistency in the determination of similar penalties for similar violations.</p>

VSL Justifications – TPL-007-2, R8	
<p>FERC VSL G3 Violation Severity Level Assignment Should Be Consistent with the Corresponding Requirement</p>	<p>The proposed VSL is worded consistently with the corresponding requirement.</p>
<p>FERC VSL G4 Violation Severity Level Assignment Should Be Based on A Single Violation, Not on A Cumulative Number of Violations</p>	<p>The proposed VSL is not based on a cumulative number of violations.</p>

VRF Justifications – TPL-007-2, R9	
<b>Proposed VRF</b>	<b>Medium</b>
FERC VRF G1 Discussion	Guideline 1- Consistency w/ Blackout Report: N/A
FERC VRF G2 Discussion	Guideline 2- Consistency within a Reliability Standard: The requirement has no sub-requirements so a single VRF was assigned.
FERC VRF G3 Discussion	Guideline 3- Consistency among Reliability Standards. A VRF of Medium is consistent with approved TPL-007-1 Requirement R5 (unchanged in proposed TPL-007-2 Requirement R5) which requires responsible entities to provide specific geomagnetically-induced currents (GIC) flow information to Transmission Owners and Generator Owners for performing transformer thermal impact assessments.

VRF Justifications – TPL-007-2, R9	
Proposed VRF	Medium
FERC VRF G4 Discussion	Guideline 4- Consistency with NERC Definitions of VRFs. The VRF of Medium is consistent with the NERC VRF Definition. Failure to provide GIC flow information for the supplemental GMD event could directly and adversely affect the electrical state or capability of the Bulk Electric System, or the ability to effectively monitor, control, or restore the Bulk Electric System during a GMD event. However, it is unlikely that such a failure by itself would lead to Bulk Electric System instability, separation, or cascading.
FERC VRF G5 Discussion	Guideline 5- Treatment of Requirements that Co-mingle More than One Obligation. This requirement does not co-mingle a higher-risk reliability objective with a lesser- risk reliability objective.



Proposed VSLs – TPL-007-2, R9			
Lower	Moderate	High	Severe
The responsible entity provided the effective GIC time series, GIC(t), in response to written request, but did so more than 90 calendar days and less than or equal to 100 calendar days after receipt of a written request.	The responsible entity provided the effective GIC time series, GIC(t), in response to written request, but did so more than 100 calendar days and less than or equal to 110 calendar days after receipt of a written request.	The responsible entity provided the effective GIC time series, GIC(t), in response to written request, but did so more than 110 calendar days after receipt of a written request.	The responsible entity did not provide the maximum effective GIC value to the Transmission Owner and Generator Owner that owns each applicable BES power transformer in the planning area; OR The responsible entity did not provide the effective GIC time series, GIC(t), upon written request.

VSL Justifications – TPL-007-2, R9	
NERC VSL Guidelines	Consistent with NERC's VSL Guidelines. The requirement may be described by elements or quantities to evaluate degrees of compliance. Four VSLs are specified for a graduated scale.

VSL Justifications – TPL-007-2, R9	
<p>FERC VSL G1 Violation Severity Level Assignments Should Not Have the Unintended Consequence of Lowering the Current Level of Compliance</p>	<p>There is no prior compliance obligation related to supplemental GMD Vulnerability Assessment. However, the requirement is similar to approved TPL-007-1, Requirement R5 (unchanged in proposed TPL-007-2 Requirement R5). That requirement also has a graduated scale for VSLs.</p>
<p>FERC VSL G2 Violation Severity Level Assignments Should Ensure Uniformity and Consistency in the Determination of Penalties Guideline 2a: The Single Violation Severity Level Assignment Category for "Binary" Requirements Is Not Consistent Guideline 2b: Violation Severity Level Assignments that Contain Ambiguous Language</p>	<p>The proposed VSL is written to ensure uniformity and consistency in the determination of penalties.</p> <p>Guideline 2a: The proposed VSL is not binary.</p> <p>Guideline 2b: The proposed VSL does not use ambiguous terms, supporting uniformity and consistency in the determination of similar penalties for similar violations.</p>
<p>FERC VSL G3 Violation Severity Level Assignment Should Be Consistent with the Corresponding Requirement</p>	<p>The proposed VSL is worded consistently with the corresponding requirement.</p>

VSL Justifications – TPL-007-2, R9	
<p>FERC VSL G4 Violation Severity Level Assignment Should Be Based on A Single Violation, Not on A Cumulative Number of Violations</p>	<p>The proposed VSL is not based on a cumulative number of violations.</p>

VRF Justifications – TPL-007-2, R10	
Proposed VRF	Medium
FERC VRF G1 Discussion	Guideline 1- Consistency w/ Blackout Report: N/A
FERC VRF G2 Discussion	Guideline 2- Consistency within a Reliability Standard: The requirement has no sub-requirements so a single VRF was assigned.
FERC VRF G3 Discussion	Guideline 3- Consistency among Reliability Standards. A VRF of Medium is consistent with approved TPL-007-1 Requirement R6 (unchanged in proposed TPL-007-2 Requirement R6), which requires responsible entities to conduct a benchmark thermal impact assessment for solely and jointly owned applicable transformers and provide results including suggested actions to mitigate identified impacts to planning entities.
FERC VRF G4 Discussion	Guideline 4- Consistency with NERC Definitions of VRFs. The VRF of Medium is consistent with the NERC VRF Definition. Failure to conduct a supplemental transformer thermal impact assessment could directly and adversely affect the electrical state or capability of the Bulk Electric System, or the ability to effectively monitor, control, or restore the Bulk Electric System during a GMD event. However, it is unlikely that such a failure by itself would lead to Bulk Electric System instability, separation, or cascading.

VRF Justifications – TPL-007-2, R10	
Proposed VRF	Medium
FERC VRF G5 Discussion	Guideline 5- Treatment of Requirements that Co-mingle More than One Obligation. This requirement does not co-mingle a higher-risk reliability objective with a lesser- risk reliability objective.

Proposed VSLs – TPL-007-2, R10			
Lower	Moderate	High	Severe
<p>The responsible entity failed to conduct a supplemental thermal impact assessment for 5% or less or one of its solely owned and jointly owned applicable BES power transformers (whichever is greater) where the maximum effective GIC value provided in Requirement R9, Part 9.1, is 85 A or greater per phase;</p> <p>OR</p> <p>The responsible entity conducted a supplemental thermal impact assessment for its solely owned and jointly owned applicable BES power</p>	<p>The responsible entity failed to conduct a supplemental thermal impact assessment for more than 5% up to (and including) 10% or two of its solely owned and jointly owned applicable BES power transformers (whichever is greater) where the maximum effective GIC value provided in Requirement R9, Part 9.1, is 85 A or greater per phase;</p> <p>OR</p> <p>The responsible entity conducted a supplemental thermal impact assessment for its solely owned and jointly</p>	<p>The responsible entity failed to conduct a supplemental thermal impact assessment for more than 10% up to (and including) 15% or three of its solely owned and jointly owned applicable BES power transformers (whichever is greater) where the maximum effective GIC value provided in Requirement R9, Part 9.1, is 85 A or greater per phase;</p> <p>OR</p> <p>The responsible entity conducted a supplemental thermal impact assessment for its solely owned and jointly</p>	<p>The responsible entity failed to conduct a supplemental thermal impact assessment for more than 15% or more than three of its solely owned and jointly owned applicable BES power transformers (whichever is greater) where the maximum effective GIC value provided in Requirement R9, Part 9.1, is 85 A or greater per phase;</p> <p>OR</p> <p>The responsible entity conducted a supplemental thermal impact assessment for its solely owned and jointly owned applicable BES power</p>

Proposed VSLs – TPL-007-2, R10			
Lower	Moderate	High	Severe
transformers where the maximum effective GIC value provided in Requirement R9, Part 9.1, is 85 A or greater per phase but did so more than 24 calendar months and less than or equal to 26 calendar months of receiving GIC flow information specified in Requirement R9, Part 9.1.	owned applicable BES power transformers where the maximum effective GIC value provided in Requirement R9, Part 9.1, is 85 A or greater per phase but did so more than 26 calendar months and less than or equal to 28 calendar months of receiving GIC flow information specified in Requirement R9, Part 9.1; OR The responsible entity failed to include one of the required elements as listed in Requirement R10, Parts 10.1 through 10.3.	owned applicable BES power transformers where the maximum effective GIC value provided in Requirement R9, Part 9.1, is 85 A or greater per phase but did so more than 28 calendar months and less than or equal to 30 calendar months of receiving GIC flow information specified in Requirement R9, Part 9.1; OR The responsible entity failed to include two of the required elements as listed in Requirement R10, Parts 10.1 through 10.3.	transformers where the maximum effective GIC value provided in Requirement R9, Part 9.1, is 85 A or greater per phase but did so more than 30 calendar months of receiving GIC flow information specified in Requirement R9, Part 9.1; OR The responsible entity failed to include three of the required elements as listed in Requirement R10, Parts 10.1 through 10.3.

VSL Justifications – TPL-007-2, R10	
NERC VSL Guidelines	Consistent with NERC's VSL Guidelines. The requirement may be described by elements or quantities to evaluate degrees of compliance. Four VSLs are specified for a graduated scale.

VSL Justifications – TPL-007-2, R10	
<p>FERC VSL G1 Violation Severity Level Assignments Should Not Have the Unintended Consequence of Lowering the Current Level of Compliance</p>	<p>There is no prior compliance obligation related to supplemental thermal impact assessment. However, the requirement is similar to approved TPL-007-1, Requirement R6 (unchanged in proposed TPL-007-2 Requirement R6). That requirement also has a graduated scale for VSLs.</p>
<p>FERC VSL G2 Violation Severity Level Assignments Should Ensure Uniformity and Consistency in the Determination of Penalties Guideline 2a: The Single Violation Severity Level Assignment Category for "Binary" Requirements Is Not Consistent Guideline 2b: Violation Severity Level Assignments that Contain Ambiguous Language</p>	<p>The proposed VSL is written to ensure uniformity and consistency in the determination of penalties.</p> <p>Guideline 2a: The proposed VSL is not binary.</p> <p>Guideline 2b: The proposed VSL does not use ambiguous terms, supporting uniformity and consistency in the determination of similar penalties for similar violations.</p>
<p>FERC VSL G3 Violation Severity Level Assignment Should Be Consistent with the Corresponding Requirement</p>	<p>The proposed VSL is worded consistently with the corresponding requirement.</p>

VSL Justifications – TPL-007-2, R10	
<p>FERC VSL G4 Violation Severity Level Assignment Should Be Based on A Single Violation, Not on A Cumulative Number of Violations</p>	<p>The proposed VSL is not based on a cumulative number of violations.</p>

VRF Justifications – TPL-007-2, R11	
Proposed VRF	Lower
FERC VRF G1 Discussion	Guideline 1- Consistency w/ Blackout Report: N/A
FERC VRF G2 Discussion	Guideline 2- Consistency within a Reliability Standard: The requirement has no sub-requirements so a single VRF was assigned.
FERC VRF G3 Discussion	Guideline 3- Consistency among Reliability Standards. A VRF of Lower is consistent with approved Reliability Standards requiring entities to implement processes to obtain data. These include Reliability Standard MOD-032-1 Requirement R1 and Reliability Standard IRO-010-2 Requirement R1.
FERC VRF G4 Discussion	Guideline 4- Consistency with NERC Definitions of VRFs. The VRF of Lower is consistent with the NERC VRF Definition. Failure to obtain GIC monitor data from at least one GIC monitor located in the system would not be expected to adversely affect the electrical state or capability of the Bulk Electric System, or the ability to effectively monitor, control, or restore the Bulk Electric System.
FERC VRF G5 Discussion	Guideline 5- Treatment of Requirements that Co-mingle More than One Obligation. This requirement does not co-mingle a higher-risk reliability objective with a lesser- risk reliability objective.

Proposed VSLs – TPL-007-2, R11			
Lower	Moderate	High	Severe
N/A	N/A	N/A	The responsible entity did not implement a process to obtain GIC monitor data from at least one GIC monitor located in the Planning Coordinator’s planning area or other part of the system included in the Planning Coordinator’s GIC System Model.

VSL Justifications – TPL-007-2, R11	
NERC VSL Guidelines	Consistent with NERC's VSL Guidelines. The requirement does not have elements or quantities to evaluate degrees of compliance. A VSL of Severe is assigned for non-compliance.
FERC VSL G1 Violation Severity Level Assignments Should Not Have the Unintended Consequence of Lowering the Current Level of Compliance	There is no prior compliance obligation for this requirement.



VSL Justifications – TPL-007-2, R11	
<p>FERC VSL G2 Violation Severity Level Assignments Should Ensure Uniformity and Consistency in the Determination of Penalties Guideline 2a: The Single Violation Severity Level Assignment Category for "Binary" Requirements Is Not Consistent Guideline 2b: Violation Severity Level Assignments that Contain Ambiguous Language</p>	<p>The proposed VSL is written to ensure uniformity and consistency in the determination of penalties.</p> <p>Guideline 2a: The proposed VSL is binary and assigned a Severe VSL.</p> <p>Guideline 2b: The proposed VSL does not use ambiguous terms, supporting uniformity and consistency in the determination of similar penalties for similar violations.</p>
<p>FERC VSL G3 Violation Severity Level Assignment Should Be Consistent with the Corresponding Requirement</p>	<p>The proposed VSL is worded consistently with the corresponding requirement.</p>
<p>FERC VSL G4 Violation Severity Level Assignment Should Be Based on A Single Violation, Not on A Cumulative Number of Violations</p>	<p>The proposed VSL is not based on a cumulative number of violations.</p>

VRF Justifications – TPL-007-2, R12	
Proposed VRF	Lower
FERC VRF G1 Discussion	Guideline 1- Consistency w/ Blackout Report: N/A
FERC VRF G2 Discussion	Guideline 2- Consistency within a Reliability Standard: The requirement has no sub-requirements so a single VRF was assigned.
FERC VRF G3 Discussion	Guideline 3- Consistency among Reliability Standards. A VRF of Lower is consistent with approved Reliability Standards requiring entities to implement processes to obtain data. These include Reliability Standard MOD-032-1 Requirement R1 and Reliability Standard IRO-010-2 Requirement R1.
FERC VRF G4 Discussion	Guideline 4- Consistency with NERC Definitions of VRFs. The VRF of Lower is consistent with the NERC VRF Definition. Failure to obtain geomagnetic field data for the planning area would not be expected to adversely affect the electrical state or capability of the Bulk Electric System, or the ability to effectively monitor, control, or restore the Bulk Electric System.
FERC VRF G5 Discussion	Guideline 5- Treatment of Requirements that Co-mingle More than One Obligation. This requirement does not co-mingle a higher-risk reliability objective with a lesser- risk reliability objective.

Proposed VSLs – TPL-007-2, R12			
Lower	Moderate	High	Severe
N/A	N/A	N/A	The responsible entity did not implement a process to obtain geomagnetic field data for its Planning Coordinator’s planning area.

VSL Justifications – TPL-007-2, R12	
NERC VSL Guidelines	Consistent with NERC's VSL Guidelines. The requirement does not have elements or quantities to evaluate degrees of compliance. A VSL of Severe is assigned for non-compliance.
FERC VSL G1 Violation Severity Level Assignments Should Not Have the Unintended Consequence of Lowering the Current Level of Compliance	There is no prior compliance obligation for this requirement.
FERC VSL G2 Violation Severity Level Assignments Should Ensure Uniformity and Consistency in the Determination of Penalties Guideline 2a: The Single Violation Severity Level	The proposed VSL is written to ensure uniformity and consistency in the determination of penalties.  Guideline 2a: The proposed VSL is binary and assigned a Severe VSL.

## VSL Justifications – TPL-007-2, R12

<p>Assignment Category for "Binary" Requirements Is Not Consistent</p> <p>Guideline 2b: Violation Severity Level Assignments that Contain Ambiguous Language</p>	<p>Guideline 2b: The proposed VSL does not use ambiguous terms, supporting uniformity and consistency in the determination of similar penalties for similar violations.</p>
<p>FERC VSL G3</p> <p>Violation Severity Level Assignment Should Be Consistent with the Corresponding Requirement</p>	<p>The proposed VSL is worded consistently with the corresponding requirement.</p>
<p>FERC VSL G4</p> <p>Violation Severity Level Assignment Should Be Based on A Single Violation, Not on A Cumulative Number of Violations</p>	<p>The proposed VSL is not based on a cumulative number of violations.</p>

Consideration of Directives

*Reliability Standard for Transmission System Planned Performance for Geomagnetic Disturbance Events*

[Order No. 830](#), 156 FERC ¶ 61,215 (Sep. 22, 2016)

approving Reliability Standard TPL-007-1

## Consideration of Directives

#	P	Directive/Guidance	Resolution
1)	PP 44 47-49	<p><b>MODIFY THE BENCHMARK GMD EVENT re SPATIAL AVERAGING</b></p> <p>P44: “[T]he Commission, as proposed in the NOPR, directs NERC to develop revisions to the benchmark GMD event definition so that the reference peak geoelectric field amplitude component is not based solely on spatially-averaged data.”</p> <p>P47: “Without prejudging how NERC proposes to address the Commission’s directive, NERC’s response to this directive should satisfy the NOPR’s concern that reliance on spatially-averaged data alone does not address localized peaks that could potentially affect the reliable operation of the Bulk-Power System.”</p> <p>P48: “NERC could revise [the standard] to apply a higher reference peak geoelectric field amplitude value to assess the impact of localized hot spots on the Bulk-Power System, as suggested by the Trade Associations.”</p> <p>P49: “Consistent with Order No. 779, the Commission does not specify a particular reference peak geoelectric field amplitude value that should be applied to hot spots given present uncertainties.”</p>	<p>The directive is addressed in proposed TPL-007-2 through Requirements for applicable entities to perform supplemental geomagnetic disturbance (GMD) Vulnerability Assessments based on the supplemental GMD event. The supplemental GMD event is a defined event for assessing system performance that is not based on spatially-averaged data.</p> <p>The supplemental GMD event is described in the standard drafting team's (SDT) white paper available on the project page:</p> <p><a href="http://www.nerc.com/pa/Stand/Pages/Project-2013-03-Geomagnetic-Disturbance-Mitigation.aspx">http://www.nerc.com/pa/Stand/Pages/Project-2013-03-Geomagnetic-Disturbance-Mitigation.aspx</a></p>

## Consideration of Directives

#	P	Directive/Guidance	Resolution
2)	P65	<p><b>REVISE R6 RE SPATIAL AVERAGING</b></p> <p>P65: “Consistent with our determination above regarding the reference peak geoelectric field amplitude value, the Commission directs NERC to revise Requirement R6 to require registered entities to apply spatially averaged and non-spatially averaged peak geoelectric field values, or some equally efficient and effective alternative, when conducting thermal impact assessments.”</p>	<p>The directive is addressed in proposed TPL-007-2 Requirements R9 and R10. Applicable entities use geomagnetically-induced current (GIC) information for the supplemental GMD event to perform supplemental thermal impact assessments of applicable power transformers.</p> <p>Requirement R9 obligates responsible Planning Coordinators and Transmission Planners to provide GIC flow information to Transmission Owners and Generator Owners for performing supplemental thermal impact assessments. The GIC flow information is based on the supplemental GMD event.</p> <p>Requirement R10 obligates Transmission Owners and Generator Owners to perform supplemental thermal impact assessments on applicable power transformers and provide results to responsible Planning Coordinators and Transmission Planners.</p>

## Consideration of Directives

<p><b>3) PP 88</b> 90, 91, 92</p>	<p><b>REVISE STANDARD TO REQUIRE COLLECTION OF GMD DATA</b></p> <p>P 88: “The Commission ... adopts the NOPR proposal in relevant part and directs NERC to develop revisions to Reliability Standard TPL-007-1 to require responsible entities to collect GIC monitoring and magnetometer data as necessary to enable model validation and situational awareness, including from any devices that must be added to meet this need.</p> <p>The NERC standard drafting team should address the criteria for collecting GIC monitoring and magnetometer data discussed below and provide registered entities with sufficient guidance in terms of defining the data that must be collected, and NERC should propose in the GMD research work plan how it will determine and report on the degree to which industry is following that guidance.”</p> <p><i>GIC Requirements</i> P 91: “Each responsible entity that is a transmission owner should be required to collect necessary GIC monitoring data. However, a transmission owner should be able to apply for an exemption from the GIC monitoring data collection requirement if it demonstrates that little or no value would be added to planning and operations.</p> <p>In developing a requirement regarding the collection of GIC monitoring data, NERC should consider the following criteria discussed at the March 1, 2016 Technical Conference: (1) the GIC data is from areas found to have high GIC based on system studies; (2) the GIC data comes from sensitive installations and key parts of the transmission grid; and (3) the data comes from GIC monitors that are not situated near transportation systems using direct current (e.g., subways or light rail.”</p> <p><i>Magnetometer Requirements</i> P90: “In developing a requirement regarding the collection of</p>	<p>The directive is addressed in proposed TPL-007-2 Requirements R11 and R12.</p> <p>Requirement R11 obligates responsible Planning Coordinators and Transmission Planners to implement a process to obtain GIC monitor data from at least one GIC monitor located in the Planning Coordinator's planning area or other part of the system included in the Planning Coordinator's GIC System model. The SDT described GIC data collection criteria in the guidance section to promote consistency in achieving the reliability objective and provide responsible entities with flexibility to tailor procedures to their planning area. The guidance addresses the following considerations: monitor locations, monitor specifications, sampling interval, collection periods, data format, and data retention.</p> <p>Requirement R12 obligates responsible Planning Coordinators and Transmission Planners to implement a process to obtain geomagnetic field data for its Planning Coordinator’s planning area. Sources of geomagnetic field data include government observatories, installed equipment owned or operated by the entity, and third-party sources. Entities are referred to INTRAMAGNET guidance for criteria and considerations including data sampling rate (10-s or faster) and data format. By requiring responsible Planning Coordinators and Transmission Planners to obtain geomagnetic field data for their planning areas, the requirement ensures data is obtained from diverse geographic areas (latitudes and longitudes) of the North American Bulk-Power System.</p>
---	--	--



## Consideration of Directives

#	P	Directive/Guidance	Resolution
		<p>magnetometer data, NERC should consider the following criteria discussed at the March 1, 2016 Technical Conference: (1) the data is sampled at a cadence of at least 10-seconds or faster; (2) the data comes from magnetometers that are physically close to GIC monitors; (3) the data comes from magnetometers that are not near sources of magnetic interference (e.g., roads and local distribution networks); and (4) data is collected from magnetometers spread across wide latitudes and longitudes and from diverse physiographic regions.”</p> <p style="text-align: center;">***</p> <p>P 91: GIC monitoring and magnetometer locations should also be revisited after GIC system models are run with improved ground conductivity models. NERC may also propose to incorporate the GIC monitoring and magnetometer data collection requirements in a different Reliability Standard (e.g., real-time reliability monitoring and analysis capabilities as part of the TOP Reliability Standards).</p> <p>P 92: “[T]he Commission determines that requiring responsible entities to collect necessary GIC monitoring and magnetometer data, rather than install GIC monitors and magnetometers, affords greater flexibility while obtaining significant benefits.”</p>	

## Consideration of Directives

4)	<b>P 101, 102</b>	<p><b>REVISE TPL-007 TO REQUIRE DEADLINES FOR THE DEVELOPMENT AND COMPLETION OF CORRECTIVE ACTION PLANS</b></p> <p>P 101: “The Commission directs NERC to modify Reliability Standard TPL-007-1 to include a deadline of one year from the completion of the GMD Vulnerability Assessments to complete the development of corrective action plans.”</p> <p>P 102: “The Commission also directs NERC to modify Reliability Standard TPL-007-1 to include a two-year deadline after the development of the corrective action plan to complete the implementation of non-hardware mitigation and four-year deadline to complete hardware mitigation...”</p>	<p>The directive is addressed in proposed TPL-007-2 Requirement R7.</p> <p>Part 7.2 specifies that responsible entities must develop Corrective Action Plans (CAP) within one year of completing the benchmark GMD Vulnerability Assessment.</p> <p>Part 7.3 requires responsible entities to include a timetable in the CAP that must specify:</p> <ul style="list-style-type: none"> <li>• Specify implementation of non-hardware mitigation, if any, within two years of development of the CAP; and</li> <li>• Specify implementation of hardware mitigation, if any, within four years of development of the CAP.</li> </ul> <p>Part 7.4 provides responsible entities with flexibility to revise the CAP and timetables if situations beyond the control of the responsible entity prevent implementation of the CAP within the specified timetable. The provision is necessary to account for potential planning, siting, budgeting approval, or regulatory uncertainties associated with transmission system projects that are not within the responsible entity’s control. Responsible entities are obligated to document the revised CAP and update the revised CAP every 12 calendar months until implemented.</p> <p>Requirement R8 requires responsible entities to complete a supplemental GMD Vulnerability Assessment, based on the supplemental GMD event, to evaluate localized enhancements of geomagnetic field during a severe GMD event that could potentially affect</p>
----	-------------------	--	---

## Consideration of Directives

			<p>the reliable operation of the Bulk-Power System. Localized enhancements of geomagnetic field can result in geoelectric field values above the spatially-averaged benchmark in a local area. Part 8.3 specifies that if the responsible entity concludes that there is Cascading caused by the supplemental GMD event, then the responsible entity shall conduct an analysis of possible actions to reduce the likelihood or mitigate the impacts and the event.</p> <p>Proposed TPL-007-2 does not require responsible entities to implement a Corrective Action Plan to address impacts identified in the supplemental GMD Vulnerability Assessment because mandatory mitigation on the basis of the supplemental GMD Vulnerability Assessment may not provide effective reliability benefit or use industry resources optimally. As discussed in the Supplemental GMD Event Description white paper, the supplemental GMD event is based on a small number of observed localized enhancement events that provide only general insight into the geographic size of localized events during severe solar storms. Additionally, the state-of-the-art modeling tools do not provide entities with capabilities to realistically model localized enhancements within a severe GMD event, and as a result entities may need to employ conservative approaches in the GMD Vulnerability Assessment such as applying the localized peak geoelectric field over an entire planning area.</p> <p>The approach taken in TPL-007-2 to mitigating impacts identified in the supplemental GMD Vulnerability Assessment provides responsible entities with flexibility to consider and select actions based on entity-specific</p>
--	--	--	--

## Consideration of Directives

#	P	Directive/Guidance	Resolution
			factors. This is similar to the approach taken in Reliability Standard TPL-001-4 for extreme events (TPL-001-4 Requirement R3 Part 3.5).

# Standards Announcement

## Project 2013-03 Geomagnetic Disturbance Mitigation TPL-007-2

Final Ballot Open through October 30, 2017

### [Now Available](#)

A final ballot for **TPL-007-2 - Transmission System Planned Performance for Geomagnetic Disturbance Events** is open through **8 p.m. Eastern, Monday, October 30, 2017**.

### Balloting

In the final ballot, votes are counted by exception. Votes from the previous ballot are automatically carried over in the final ballot. Only members of the applicable ballot pools can cast a vote. Ballot pool members who previously voted have the option to change their vote in the final ballot. Ballot pool members who did not cast a vote during the previous ballot can vote in the final ballot.

Members of the ballot pool associated with this project can log in and submit their vote [here](#). If you experience any difficulties using the Standards Balloting & Commenting System (SBS), contact [Nasheema Santos](#).

*If you are having difficulty accessing the SBS due to a forgotten password, incorrect credential error messages, or system lock-out, contact NERC IT support directly at <https://support.nerc.net/> (Monday – Friday, 8 a.m. - 5 p.m. Eastern).*

- *Passwords expire every **6 months** and must be reset.*
- *The SBS **is not** supported for use on mobile devices.*
- *Please be mindful of ballot and comment period closing dates. We ask to **allow at least 48 hours** for NERC support staff to assist with inquiries. Therefore, it is recommended that users try logging into their SBS accounts **prior to the last day** of a comment/ballot period.*

### Next Steps

The voting results will be posted and announced after the ballot closes. If approved, the standard will be submitted to the Board of Trustees for adoption and then filed with the appropriate regulatory authorities.

### Standards Development Process

For more information on the Standards Development Process, refer to the [Standard Processes Manual](#).

For more information or assistance, contact Senior Standards Developer, [Scott Barfield-McGinnis](#) via email or at (404) 446-9689.

North American Electric Reliability Corporation  
3353 Peachtree Rd, NE  
Suite 600, North Tower  
Atlanta, GA 30326  
404-446-2560 | [www.nerc.com](http://www.nerc.com)

# Implementation Plan

## Project 2013-03 Geomagnetic Disturbance Mitigation Reliability Standard TPL-007-2

### Applicable Standard

- TPL-007-2 - Transmission System Planned Performance for Geomagnetic Disturbance Events

### Requested Retirement

- TPL-007-1 - Transmission System Planned Performance for Geomagnetic Disturbance Events

### Prerequisite Standard

None

### Applicable Entities

- *Planning Coordinator with a planning area that includes a Facility or Facilities specified in Section 4.2 of the standard;*
- *Transmission Planner with a planning area that includes a Facility or Facilities specified in Section 4.2 of the standard;*
- *Transmission Owner who owns a Facility or Facilities specified in Section 4.2 of the standard; and*
- *Generator Owner who owns a Facility or Facilities specified in Section 4.2 of the standard.*

Section 4.2 states that the standard applies to facilities that include power transformer(s) with a high-side, wye-grounded winding with terminal voltage greater than 200 kV.

### Terms in the NERC Glossary of Terms

There are no new, modified, or retired terms.

### Background

On September 22, 2016, the Federal Energy Regulatory Commission (FERC) issued Order No. 830 approving Reliability Standard TPL-007-1 and its associated five-year Implementation Plan. In the Order, FERC also directed NERC to develop certain modifications to the standard. FERC established a deadline of 18 months from the effective date of Order No. 830 for completing the revisions, which is May 2018.

### General Considerations

This Implementation Plan is intended to integrate the new requirements in TPL-007-2 with the GMD Vulnerability Assessment process that is being implemented through approved TPL-007-1. At the time of the May 2018 filing deadline, many requirements in approved standard TPL-007-1 that lead

to completion of the geomagnetic disturbance (GMD) Vulnerability Assessment will be in effect. Furthermore, many entities may be taking steps to complete studies or assessments that are required by future enforceable requirements in TPL-007-1. The Implementation Plan phases in the requirements in TPL-007-2 based on the effective date of TPL-007-2, as follows:

- **Effective Date before January 1, 2021.** Implementation timeline supports applicable entities completing new requirements for supplemental GMD Vulnerability Assessments concurrently with requirements for the benchmark GMD Vulnerability Assessment (concurrent effective dates).
- **Effective Date on or after January 1, 2021.** Implementation timeline supports applicable entities completing the benchmark GMD Vulnerability Assessments before new requirements for supplemental GMD Vulnerability Assessments become effective.

### **Effective Date**

The effective date for the proposed Reliability Standard is provided below. Where the standard drafting team identified the need for a longer implementation period for compliance with a particular section of the proposed Reliability Standard (e.g., an entire Requirement or a portion thereof), the additional time for compliance with that section is specified below. These phased-in compliance dates represent the dates that entities must begin to comply with that particular section of the Reliability Standard, even where the Reliability Standard goes into effect at an earlier date.

### **Standard TPL-007-2**

Where approval by an applicable governmental authority is required, the standard shall become effective on the first day of the first calendar quarter that is three (3) months after the effective date of the applicable governmental authority's order approving the standard, or as otherwise provided for by the applicable governmental authority.

Where approval by an applicable governmental authority is not required, the standard shall become effective on the first day of the first calendar quarter that is three (3) months after the date the standard is adopted by the NERC Board of Trustees, or as otherwise provided for in that jurisdiction.

### **Phased-In Compliance Dates**

#### ***If TPL-007-2 becomes effective before January 1, 2021***

Implementation timeline supports applicable entities completing new requirements for supplemental GMD Vulnerability Assessments concurrently with requirements for the benchmark GMD Vulnerability Assessment (concurrent effective dates).

### **Compliance Date for TPL-007-2 Requirements R1 and R2**

Entities shall be required to comply with Requirements R1 and R2 upon the effective date of Reliability Standard TPL-007-2.



**Compliance Date for TPL-007-2 Requirement R5**

Entities shall not be required to comply with Requirements R5 until six (6) months after the effective date of Reliability Standard TPL-007-2.

**Compliance Date for TPL-007-2 Requirement R9**

Entities shall not be required to comply with Requirement R9 until six (6) months after the effective date of Reliability Standard TPL-007-2.

**Compliance Date for TPL-007-2 Requirements R11 and R12**

Entities shall not be required to comply with Requirements R11 and R12 until 24 months after the effective date of Reliability Standard TPL-007-2.

**Compliance Date for TPL-007-2 Requirements R6 and R10**

Entities shall not be required to comply with Requirements R6 and R10 until 30 months after the effective date of Reliability Standard TPL-007-2.

**Compliance Date for TPL-007-2 Requirements R3, R4, and R8**

Entities shall not be required to comply with Requirements R3, R4, and R8 until 42 months after the effective date of Reliability Standard TPL-007-2.

**Compliance Date for TPL-007-2 Requirement R7**

Entities shall not be required to comply with Requirement R7 until 54 months after the effective date of Reliability Standard TPL-007-2.

***If TPL-007-2 becomes effective on or after January 1, 2021***

Implementation timeline supports applicable entities completing the benchmark GMD Vulnerability Assessments before new requirements for supplemental GMD Vulnerability Assessments become effective.

**Compliance Date for TPL-007-2 Requirements R1, R2, R5, and R6**

Entities shall be required to comply with Requirements R1, R2, R5, and R6 upon the effective date of Reliability Standard TPL-007-2.

**Compliance Date for TPL-007-2 Requirements R3 and R4**

Entities shall not be required to comply with Requirements R3 and R4 until 12 months after the effective date of Reliability Standard TPL-007-2.

**Compliance Date for TPL-007-2 Requirements R7, R11, and R12**

Entities shall not be required to comply with Requirements R7, R11, and R12 until 24 months after the effective date of Reliability Standard TPL-007-2.

#### **Compliance Date for TPL-007-2 Requirement R9**

Entities shall not be required to comply with Requirement R9 until 36 months after the effective date of Reliability Standard TPL-007-2.

#### **Compliance Date for TPL-007-2 Requirement R10**

Entities shall not be required to comply with Requirement R10 until 60 months after the effective date of Reliability Standard TPL-007-2.

#### **Compliance Date for TPL-007-2 Requirement R8**

Entities shall not be required to comply with Requirement R8 until 72 months after the effective date of Reliability Standard TPL-007-2.

#### **Retirement Date**

##### **Standard TPL-007-1**

Reliability Standard TPL-007-1 shall be retired immediately prior to the effective date of TPL-007-2 in the particular jurisdiction in which the revised standard is becoming effective.

#### **Initial Performance of Periodic Requirements**

Transmission Owners and Generator Owners are not required to comply with Requirement R6 prior to the compliance date for Requirement R6, regardless of when geomagnetically-induced current (GIC) flow information specified in Requirement R5, Part 5.1 is received.

Transmission Owners and Generator Owners are not required to comply with Requirement R10 prior to the compliance date for Requirement R10, regardless of when GIC flow information specified in Requirement R9, Part 9.1 is received.

# Implementation Plan

## Project 2013-03 Geomagnetic Disturbance Mitigation Reliability Standard TPL-007-2

### Applicable Standard

- TPL-007-2 - Transmission System Planned Performance for Geomagnetic Disturbance Events

### Requested Retirement

- TPL-007-1 - Transmission System Planned Performance for Geomagnetic Disturbance Events

### Prerequisite Standard

None

### Applicable Entities

- *Planning Coordinator with a planning area that includes a Facility or Facilities specified in Section 4.2 of the standard;*
- *Transmission Planner with a planning area that includes a Facility or Facilities specified in Section 4.2 of the standard;*
- *Transmission Owner who owns a Facility or Facilities specified in Section 4.2 of the standard; and*
- *Generator Owner who owns a Facility or Facilities specified in Section 4.2 of the standard.*

Section 4.2 states that the standard applies to facilities that include power transformer(s) with a high-side, wye-grounded winding with terminal voltage greater than 200 kV.

### Terms in the NERC Glossary of Terms

There are no new, modified, or retired terms.

### Background

On September 22, 2016, the Federal Energy Regulatory Commission (FERC) issued Order No. 830 approving Reliability Standard TPL-007-1 and its associated five-year Implementation Plan. In the Order, FERC also directed NERC to develop certain modifications to the standard. FERC established a deadline of 18 months from the effective date of Order No. 830 for completing the revisions, which is May 2018.

### General Considerations

This Implementation Plan is intended to integrate the new requirements in TPL-007-2 with the GMD Vulnerability Assessment process that is being implemented through approved TPL-007-1. At the time of the May 2018 filing deadline, many requirements in approved standard TPL-007-1 that lead to completion of the geomagnetic disturbance (GMD) Vulnerability Assessment will be in effect. Furthermore, many entities may be taking steps to complete studies or assessments that are

required by future enforceable requirements in TPL-007-1. The Implementation Plan phases in the requirements in TPL-007-2 based on the effective date of TPL-007-2, as follows:

- **Effective Date before January 1, 2021.** Implementation timeline supports applicable entities completing new requirements for supplemental GMD Vulnerability Assessments concurrently with requirements for the benchmark GMD Vulnerability Assessment (concurrent effective dates).
- **Effective Date on or after January 1, 2021.** Implementation timeline supports applicable entities completing the benchmark GMD Vulnerability Assessments before new requirements for supplemental GMD Vulnerability Assessments become effective.

### **Effective Date**

The effective date for the proposed Reliability Standard is provided below. Where the standard drafting team identified the need for a longer implementation period for compliance with a particular section of the proposed Reliability Standard (e.g., an entire Requirement or a portion thereof), the additional time for compliance with that section is specified below. These phased-in compliance dates represent the dates that entities must begin to comply with that particular section of the Reliability Standard, even where the Reliability Standard goes into effect at an earlier date.

### **Standard TPL-007-2**

Where approval by an applicable governmental authority is required, the standard shall become effective on the first day of the first calendar quarter that is three (3) months after the effective date of the applicable governmental authority's order approving the standard, or as otherwise provided for by the applicable governmental authority.

Where approval by an applicable governmental authority is not required, the standard shall become effective on the first day of the first calendar quarter that is three (3) months after the date the standard is adopted by the NERC Board of Trustees, or as otherwise provided for in that jurisdiction.

### **Phased-In Compliance Dates**

#### ***If TPL-007-2 becomes effective before January 1, 2021***

Implementation timeline supports applicable entities completing new requirements for supplemental GMD Vulnerability Assessments concurrently with requirements for the benchmark GMD Vulnerability Assessment (concurrent effective dates).

### **Compliance Date for TPL-007-2 Requirements R1 and R2**

Entities shall be required to comply with Requirements R1 and R2 upon the effective date of Reliability Standard TPL-007-2.

### **Compliance Date for TPL-007-2 Requirement R5**

Entities shall not be required to comply with Requirements R5 until six (6) months after the effective date of Reliability Standard TPL-007-2.

**Compliance Date for TPL-007-2 Requirement R9**

Entities shall not be required to comply with Requirement R9 until six (6) months after the effective date of Reliability Standard TPL-007-2.

**Compliance Date for TPL-007-2 Requirements R11 and R12**

Entities shall not be required to comply with Requirements R11 and R12 until 24 months after the effective date of Reliability Standard TPL-007-2.

**Compliance Date for TPL-007-2 Requirements R6 and R10**

Entities shall not be required to comply with Requirements R6 and R10 until 30 months after the effective date of Reliability Standard TPL-007-2.

**Compliance Date for TPL-007-2 Requirements R3, R4, and R8**

Entities shall not be required to comply with Requirements R3, R4, and R8 until 42 months after the effective date of Reliability Standard TPL-007-2.

**Compliance Date for TPL-007-2 Requirement R7**

Entities shall not be required to comply with Requirement R7 until 54 months after the effective date of Reliability Standard TPL-007-2.

***If TPL-007-2 becomes effective on or after January 1, 2021***

Implementation timeline supports applicable entities completing the benchmark GMD Vulnerability Assessments before new requirements for supplemental GMD Vulnerability Assessments become effective.

**Compliance Date for TPL-007-2 Requirements R1, R2, R5, and R6**

Entities shall be required to comply with Requirements R1, R2, R5, and R6 upon the effective date of Reliability Standard TPL-007-2.

**Compliance Date for TPL-007-2 Requirements R3 and R4**

Entities shall not be required to comply with Requirements R3 and R4 until 12 months after the effective date of Reliability Standard TPL-007-2.

**Compliance Date for TPL-007-2 Requirements R7, R11, and R12**

Entities shall not be required to comply with Requirements R7, R11, and R12 until 24 months after the effective date of Reliability Standard TPL-007-2.

**Compliance Date for TPL-007-2 Requirement R9**

Entities shall not be required to comply with Requirement R9 until 36 months after the effective date of Reliability Standard TPL-007-2.

### **Compliance Date for TPL-007-2 Requirement R10**

Entities shall not be required to comply with Requirement R10 until 60 months after the effective date of Reliability Standard TPL-007-2.

### **Compliance Date for TPL-007-2 Requirement R8**

Entities shall not be required to comply with Requirement R8 until 72 months after the effective date of Reliability Standard TPL-007-2.

### **Retirement Date**

#### **Standard TPL-007-1**

Reliability Standard TPL-007-1 shall be retired immediately prior to the effective date of TPL-007-2 in the particular jurisdiction in which the revised standard is becoming effective, ~~provided that the TPL-007-1 Implementation Plan shall remain in effect to the extent necessary until the phased-in compliance dates above are implemented for TPL-007-2.~~

### **Initial Performance of Periodic Requirements**

Transmission Owners and Generator Owners are not required to comply with Requirement R6 prior to the compliance date for Requirement R6, regardless of when geomagnetically-induced current (GIC) flow information specified in Requirement R5, Part 5.1 is received.

Transmission Owners and Generator Owners are not required to comply with Requirement R10 prior to the compliance date for Requirement R10, regardless of when GIC flow information specified in Requirement R9, Part 9.1 is received.

**Exhibit E**

**Order No. 672 Criteria for Proposed Reliability Standard TPL-007-2**

## Exhibit E -- Order No. 672 Criteria

### Order No. 672 Criteria

In Order No. 672,<sup>1</sup> the Commission identified a number of criteria it will use to analyze Reliability Standards proposed for approval to ensure they are just, reasonable, not unduly discriminatory or preferential, and in the public interest. The discussion below identifies these factors and explains how the proposed Reliability Standard has met or exceeded the criteria.

**1. Proposed Reliability Standards must be designed to achieve a specified reliability goal and must contain a technically sound means to achieve that goal.<sup>2</sup>**

Proposed Reliability Standard TPL-007-2 addresses the unique risks posed by a high-impact, low-frequency geomagnetic disturbance (“GMD”) event on the reliable operation of the Bulk-Power System (“BPS”) and is responsive to the Commission’s directives in Order No. 830. Reliability Standard TPL-007-1 requires applicable entities to conduct initial and on-going assessments of the potential impact of a benchmark GMD event on BPS equipment and the BPS as a whole and requires corrective action to protect against instability, uncontrolled separation,

---

<sup>1</sup> *Rules Concerning Certification of the Electric Reliability Organization; and Procedures for the Establishment, Approval, and Enforcement of Electric Reliability Standards*, Order No. 672, FERC Stats. & Regs. ¶ 31,204, *order on reh’g*, Order No. 672-A, FERC Stats. & Regs. ¶ 31,212 (2006).

<sup>2</sup> Order No. 672 at P 321. The proposed Reliability Standard must address a reliability concern that falls within the requirements of section 215 of the FPA. That is, it must provide for the reliable operation of Bulk-Power System facilities. It may not extend beyond reliable operation of such facilities or apply to other facilities. Such facilities include all those necessary for operating an interconnected electric energy transmission network, or any portion of that network, including control systems. The proposed Reliability Standard may apply to any design of planned additions or modifications of such facilities that is necessary to provide for reliable operation. It may also apply to Cybersecurity protection.

Order No. 672 at P 324. The proposed Reliability Standard must be designed to achieve a specified reliability goal and must contain a technically sound means to achieve this goal. Although any person may propose a topic for a Reliability Standard to the ERO, in the ERO’s process, the specific proposed Reliability Standard should be developed initially by persons within the electric power industry and community with a high level of technical expertise and be based on sound technical and engineering criteria. It should be based on actual data and lessons learned from past operating incidents, where appropriate. The process for ERO approval of a proposed Reliability Standard should be fair and open to all interested persons.



and cascading failures of the BPS. Proposed Reliability Standard TPL-007-2 improves upon the current version of the standard by using the latest developments in GMD research to provide enhanced criteria and requirements to address reliability risks arising from GMDs, including the risks posed by severe, localized events. The proposed standard would require entities to perform a second, or supplemental, GMD Vulnerability Assessment based on the supplemental GMD event. As described in **Exhibit I** to this Petition, this supplemental GMD event is designed to account for the localized peak effects of severe GMD events on systems and equipment.

The proposed standard also contains revisions to require the collection of GIC and magnetometer data to inform GMD Vulnerability Assessments and to implement Commission-specified deadlines for the development and completion of any necessary Corrective Action Plans.

**2. Proposed Reliability Standards must be applicable only to users, owners and operators of the bulk power system, and must be clear and unambiguous as to what is required and who is required to comply.<sup>3</sup>**

The proposed Reliability Standard is clear and unambiguous as to what is required and who is required to comply, in accordance with Order No. 672. Consistent with currently-effective Reliability Standard TPL-007-1, proposed Reliability Standard TPL-007-2 is applicable to: (1) Planning Coordinators with a planning area that includes a power transformer(s) with a high side, wye-grounded winding with terminal voltage greater than 200 kV; (2) Transmission Planners with a planning area that includes a power transformer(s) with a high side, wye-grounded winding with terminal voltage greater than 200 kV; (3) Transmission Owners that own

---

<sup>3</sup> Order No. 672 at P 322. The proposed Reliability Standard may impose a requirement on any user, owner, or operator of such facilities, but not on others.

Order No. 672 at P 325. The proposed Reliability Standard should be clear and unambiguous regarding what is required and who is required to comply. Users, owners, and operators of the Bulk-Power System must know what they are required to do to maintain reliability.

a Facility or Facilities that include a power transformer(s) with a high side, wye-grounded winding with terminal voltage greater than 200 kV; and (4) Generator Owners that own a Facility or Facilities that include a power transformer(s) with a high side, wye-grounded winding with terminal voltage greater than 200 kV.<sup>4</sup> The proposed Reliability Standard clearly articulates the actions that such entities must take to comply with the standard.

**3. A proposed Reliability Standard must include clear and understandable consequences and a range of penalties (monetary and/or non-monetary) for a violation.<sup>5</sup>**

The Violation Risk Factors (“VRFs”) and Violation Severity Levels (“VSLs”) for the proposed Reliability Standard comport with NERC and Commission guidelines related to their assignment. The assignment of the severity level for each VSL is consistent with the corresponding requirement and the VSLs should ensure uniformity and consistency in the determination of penalties. The VSLs do not use any ambiguous terminology, thereby supporting uniformity and consistency in the determination of similar penalties for similar violations. For these reasons, the proposed Reliability Standard includes clear and understandable consequences in accordance with Order No. 672.

**4. A proposed Reliability Standard must identify clear and objective criterion or measure for compliance, so that it can be enforced in a consistent and non-preferential manner.<sup>6</sup>**

The proposed Reliability Standard contains Measures that support each Requirement by clearly identifying what is required and how the Requirement will be enforced. These measures

---

<sup>4</sup> A power transformer with a “high side wye-grounded winding” refers to a power transformer with windings on the high voltage side that are connected in a wye configuration and have a grounded neutral connection.

<sup>5</sup> Order No. 672 at P 326. The possible consequences, including range of possible penalties, for violating a proposed Reliability Standard should be clear and understandable by those who must comply.

<sup>6</sup> Order No. 672 at P 327. There should be a clear criterion or measure of whether an entity is in compliance with a proposed Reliability Standard. It should contain or be accompanied by an objective measure of compliance so that it can be enforced and so that enforcement can be applied in a consistent and non-preferential manner.

help provide clarity regarding how the Requirements will be enforced and help ensure that the Requirements will be enforced in a clear, consistent, and non-preferential manner and without prejudice to any party.

**5. Proposed Reliability Standards should achieve a reliability goal effectively and efficiently — but do not necessarily have to reflect “best practices” without regard to implementation cost or historical regional infrastructure design.<sup>7</sup>**

The proposed Reliability Standard achieves its reliability goals effectively and efficiently in accordance with Order No. 672. The proposed Reliability Standard clearly enumerates the responsibilities of applicable entities with respect to conducting initial and on-going assessments of the potential impact of defined GMD events on BPS equipment and the BPS as a whole and provides entities the flexibility to select appropriate mitigation strategies to address identified vulnerabilities.

**6. Proposed Reliability Standards cannot be “lowest common denominator,” i.e., cannot reflect a compromise that does not adequately protect Bulk-Power System reliability. Proposed Reliability Standards can consider costs to implement for smaller entities, but not at consequences of less than excellence in operating system reliability.<sup>8</sup>**

The proposed Reliability Standard does not reflect a “lowest common denominator” approach. To the contrary, the proposed Reliability Standard contains significant reliability

---

<sup>7</sup> Order No. 672 at P 328. The proposed Reliability Standard does not necessarily have to reflect the optimal method, or “best practice,” for achieving its reliability goal without regard to implementation cost or historical regional infrastructure design. It should however achieve its reliability goal effectively and efficiently.

<sup>8</sup> Order No. 672 at P 329. The proposed Reliability Standard must not simply reflect a compromise in the ERO’s Reliability Standard development process based on the least effective North American practice — the so-called “lowest common denominator” — if such practice does not adequately protect Bulk-Power System reliability. Although FERC will give due weight to the technical expertise of the ERO, we will not hesitate to remand a proposed Reliability Standard if we are convinced it is not adequate to protect reliability.

Order No. 672 at P 330. A proposed Reliability Standard may take into account the size of the entity that must comply with the Reliability Standard and the cost to those entities of implementing the proposed Reliability Standard. However, the ERO should not propose a “lowest common denominator” Reliability Standard that would achieve less than excellence in operating system reliability solely to protect against reasonable expenses for supporting this vital national infrastructure. For example, a small owner or operator of the Bulk-Power System must bear the cost of complying with each Reliability Standard that applies to it.

benefits for the BPS and addresses directives and concerns identified by the Commission in Order No. 830. The provisions of the proposed standard raise the level of preparedness by requiring applicable entities to plan for the reliable operation of the BPS during a second severe GMD event, one that is intended to account for localized peak effects. The proposed Reliability Standard and the new supplemental GMD event incorporate rigorous technical analysis that is representative of the complex nature of space weather phenomena and reflects a balanced and practical approach. By instituting Requirements for the collection of GIC and magnetometer data, the proposed standard increases the amount of information available to inform GMD Vulnerability Assessments. Lastly, the proposed standard revises Requirements for Corrective Action Plans to implement Commission-directed deadlines for their development and completion while also providing an accountability-driven process to manage any revisions that may become necessary due to circumstances outside of the entity's control.

- 7. Proposed Reliability Standards must be designed to apply throughout North America to the maximum extent achievable with a single Reliability Standard while not favoring one geographic area or regional model. It should take into account regional variations in the organization and corporate structures of transmission owners and operators, variations in generation fuel type and ownership patterns, and regional variations in market design if these affect the proposed Reliability Standard.<sup>9</sup>**

The proposed Reliability Standard applies consistently throughout North America and does not favor one geographic area or regional model. The proposed standard includes technically-justified scaling factors that allow for entity-specific tailoring of the benchmark and

---

<sup>9</sup> Order No. 672 at P 331. A proposed Reliability Standard should be designed to apply throughout the interconnected North American Bulk-Power System, to the maximum extent this is achievable with a single Reliability Standard. The proposed Reliability Standard should not be based on a single geographic or regional model but should take into account geographic variations in grid characteristics, terrain, weather, and other such factors; it should also take into account regional variations in the organizational and corporate structures of transmission owners and operators, variations in generation fuel type and ownership patterns, and regional variations in market design if these affect the proposed Reliability Standard.

supplemental GMD events. This approach provides for consistent application of the proposed Reliability Standard throughout North America while still accounting for the varying impact GMD events may have on each region.

**8. Proposed Reliability Standards should cause no undue negative effect on competition or restriction of the grid beyond any restriction necessary for reliability.<sup>10</sup>**

Proposed Reliability Standard TPL-007-2 has no undue negative effect on competition and does not unreasonably restrict the available transmission capacity or limit the use of the BPS in a preferential manner. The proposed standard requires the same performance by each of the applicable entities. The information sharing required by the proposed standard is necessary for reliability and can be accomplished without presenting any market or competition-related concerns.

**9. The implementation time for the proposed Reliability Standard is reasonable.<sup>11</sup>**

The proposed effective date for proposed Reliability Standard TPL-007-2 is just and reasonable and appropriately balances the urgency in the need to implement the standard against the reasonableness of the time allowed for those who must comply to develop necessary procedures, software, facilities, staffing or other relevant capability. The proposed implementation plan recognizes that several Requirements in TPL-007-1 are or will soon become effective, and that many entities may now be taking steps to complete the studies or assessments

---

<sup>10</sup> Order No. 672 at P 332. As directed by section 215 of the FPA, FERC itself will give special attention to the effect of a proposed Reliability Standard on competition. The ERO should attempt to develop a proposed Reliability Standard that has no undue negative effect on competition. Among other possible considerations, a proposed Reliability Standard should not unreasonably restrict available transmission capability on the Bulk-Power System beyond any restriction necessary for reliability and should not limit use of the Bulk-Power System in an unduly preferential manner. It should not create an undue advantage for one competitor over another.

<sup>11</sup> Order No. 672 at P 333. In considering whether a proposed Reliability Standard is just and reasonable, FERC will consider also the timetable for implementation of the new requirements, including how the proposal balances any urgency in the need to implement it against the reasonableness of the time allowed for those who must comply to develop the necessary procedures, software, facilities, staffing or other relevant capability.

required by other Requirements in TPL-007-1 that will become enforceable in the future. NERC's proposed implementation plan therefore contains two phased compliance timelines based on the effective date of TPL-007-2: one timeline would support the concurrent completion of the benchmark and supplemental GMD Vulnerability Assessments, while the second would have entities complete benchmark GMD Vulnerability Assessments first and then complete supplemental GMD Vulnerability Assessments during the next assessment cycle. Either option would allow applicable entities adequate time to ensure compliance with the Requirements. The proposed implementation plan is attached as **Exhibit B** to this Petition.

**10. The Reliability Standard was developed in an open and fair manner and in accordance with the Commission-approved Reliability Standard development process.<sup>12</sup>**

The proposed Reliability Standard was developed in accordance with NERC's Commission-approved, ANSI-accredited processes for developing and approving Reliability Standards. **Exhibit D** includes a summary of the Reliability Standard development proceedings, and details the processes followed to develop the proposed Reliability Standard. These processes included, among other things, multiple comment periods, pre-ballot review periods, and balloting periods. Additionally, all meetings of the standard drafting team were properly noticed and open to the public.

---

<sup>12</sup> Order No. 672 at P 334. Further, in considering whether a proposed Reliability Standard meets the legal standard of review, we will entertain comments about whether the ERO implemented its Commission-approved Reliability Standard development process for the development of the particular proposed Reliability Standard in a proper manner, especially whether the process was open and fair. However, we caution that we will not be sympathetic to arguments by interested parties that choose, for whatever reason, not to participate in the ERO's Reliability Standard development process if it is conducted in good faith in accordance with the procedures approved by FERC.

**11. NERC must explain any balancing of vital public interests in the development of proposed Reliability Standards.<sup>13</sup>**

NERC has identified no competing public interests regarding the request for approval of this proposed Reliability Standard. No comments were received that indicated the proposed Reliability Standard conflicts with other vital public interests.

**12. Proposed Reliability Standards must consider any other appropriate factors.<sup>14</sup>**

No other negative factors relevant to whether the proposed Reliability Standard is just and reasonable were identified.

---

<sup>13</sup> Order No. 672 at P 335. Finally, we understand that at times development of a proposed Reliability Standard may require that a particular reliability goal must be balanced against other vital public interests, such as environmental, social and other goals. We expect the ERO to explain any such balancing in its application for approval of a proposed Reliability Standard.

<sup>14</sup> Order No. 672 at P 323. In considering whether a proposed Reliability Standard is just and reasonable, we will consider the following general factors, as well as other factors that are appropriate for the particular Reliability Standard proposed.

**Exhibit F**

**Standard Drafting Team Roster for Project 2013-03**



## Standard Drafting Team Roster

### Project 2013-03 Geomagnetic Disturbance Mitigation

	Name	Entity
<b>Chair</b>	Frank Koza	PJM Interconnection
<b>Members</b>	Donald Atkinson	Georgia Transmission Corporation
	Emanuel Bernabeu	PJM Interconnection
	Louis Gibson	Hydro Quebec
	Per-Anders Lof	National Grid
	Jow Ortiz	NextEra Florida Power & Light
	Ralph Painter	Tampa Electric Co
	Antti Pulkkinen	NASA Goddard Space Flight Center
	Qun Qiu	American Electric Power
	Mike Steckelberg	Great River Energy
	Rui Sun	Dominion Virginia Power
	Berhanu Tesema	Bonneville Power Authority
<b>PMOS Liaison</b>	Jennifer Sterling	Exelon Corp
<b>NERC Staff</b>	Scott Barfield-McGinnis, Senior Standards Developer	North American Electric Reliability Corporation
	Mark Olson, Senior Standards Developer	North American Electric Reliability Corporation
	Lauren Perotti, Counsel	North American Electric Reliability Corporation

## **Exhibit G**

### **Transformer Thermal Impact Assessment White Paper**

# Transformer Thermal Impact Assessment White Paper

## TPL-007-2 – Transmission System Planned Performance for Geomagnetic Disturbance Events

### Background

Proposed TPL-007-2 includes requirements for entities to perform two types of geomagnetic disturbance (GMD) Vulnerability Assessments to evaluate the potential impacts of GMD events on the Bulk Electric System (BES):

- The benchmark GMD Vulnerability Assessment is based on the benchmark GMD event associated with TPL-007-1 which was approved by the Federal Energy Regulatory Commission (FERC) in Order No. 830 in September 2016. The benchmark GMD event is derived from spatially-averaged geoelectric field values to address potential wide-area effects that could be caused by a severe 1-in-100 year GMD event.<sup>1</sup>
- The supplemental GMD Vulnerability Assessment, based on the supplemental GMD event, is used by entities to evaluate localized peaks in geomagnetic field during a severe GMD event that "could potentially affect the reliable operation of the Bulk-Power System."<sup>2</sup> Localized enhancements of geomagnetic field can result in geoelectric field values above the spatially-averaged benchmark in a local area.

The standard requires transformer thermal impact assessments to be performed on BES power transformers with high side, wye-grounded windings with terminal voltage greater than 200 kV. Large power transformers connected to the extra-high voltage (EHV) transmission system can experience both winding and structural hot spot heating as a result of GMD events. TPL-007-2 requires owners of such BES transformers to conduct thermal analyses to determine if the BES transformers will be able to withstand the thermal transient effects associated with the GMD events. BES transformers must undergo a thermal impact assessment if the maximum effective geomagnetically-induced current (GIC) in the transformer is equal to or greater than:<sup>3</sup>

- 75 A per phase for the benchmark GMD event
- 85 A per phase for the supplemental GMD event

This white paper discusses methods that can be employed to conduct transformer thermal impact assessments, including example calculations. The first version of the white paper was developed by the Project 2013-03 GMD Standards Drafting Team (SDT) for TPL-007-1 and was endorsed by the Electric

<sup>1</sup> See *Benchmark Geomagnetic Disturbance Event Description* white paper, May 12, 2016. Filed by NERC in RM15-11 on June 28, 2016.

<sup>2</sup> See Order No. 830 P. 47. On September 22, 2016, FERC directed NERC to develop modifications to the benchmark GMD event, included in TPL-007-1, such that assessments would not be based solely on spatially averaged data. The characteristics of a GMD event for this assessment are in the Supplemental GMD Event Description white paper.

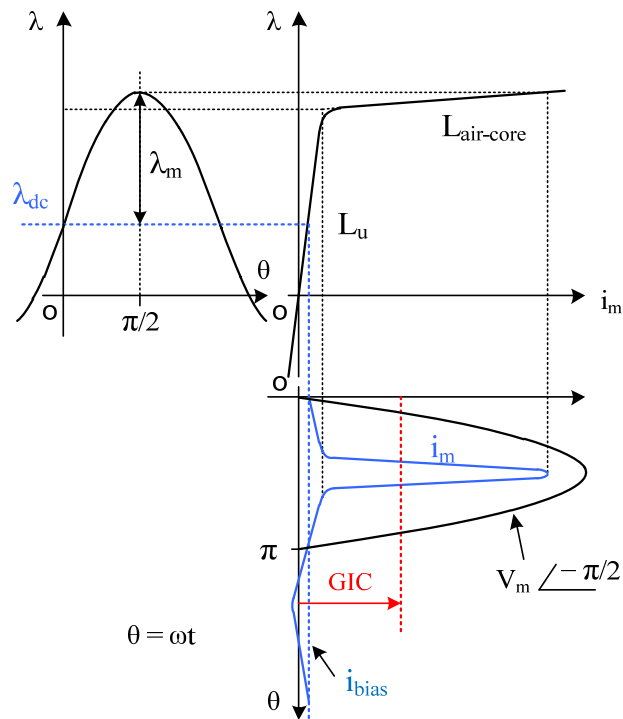
<sup>3</sup> See *Screening Criterion for Transformer Thermal Impact Assessment* for technical justification.

Reliability Organization (ERO) as implementation guidance in October 2016. The SDT has updated the white paper to include the supplemental GMD event that is added in TPL-007-2 to address directives in FERC Order No. 830.

The primary impact of GMDs on large power transformers is a result of the quasi-dc current that flows through wye-grounded transformer windings. This GIC results in an offset of the ac sinusoidal flux resulting in asymmetric or half-cycle saturation (see Figure 1).

Half-cycle saturation results in a number of known effects:

- Hot spot heating of transformer windings due to harmonics and stray flux;
- Hot spot heating of non-current carrying transformer metallic members due to stray flux;
- Harmonics;
- Increase in reactive power absorption; and
- Increase in vibration and noise level.



**Figure 1: Mapping Magnetization Current to Flux through Core Excitation Characteristics**

This paper focuses on hot spot heating of transformer windings and non-current-carrying metallic parts. Effects such as the generation of harmonics, increase in reactive power absorption, vibration, and noise are not within the scope of this document.

## Technical Considerations

The effects of half-cycle saturation on high-voltage (HV) and EHV transformers, namely localized “hot spot” heating, are relatively well understood, but are difficult to quantify. A transformer GMD impact assessment must consider GIC amplitude, duration, and transformer physical characteristics such as design and condition (e.g., age, gas content, and moisture in the oil). A single threshold value of GIC cannot be justified as a “pass or fail” screening criterion where “fail” means that the transformer will suffer damage. A single threshold value of GIC only makes sense in the context where “fail” means that a more detailed study is required. Such a threshold would have to be technically justifiable and sufficiently low to be considered a conservative value of GIC.

The following considerations should be taken into account when assessing the thermal susceptibility of a transformer to half-cycle saturation:

- In the absence of manufacturer specific information, use the temperature limits for safe transformer operation such as those suggested in the IEEE Std C57.91-2011 (IEEE Guide for Loading Mineral-oil-immersed Transformers and Step-voltage Regulators) for hot spot heating during short-term emergency operation [1]. This standard does not suggest that exceeding these limits will result in transformer failure, but rather that it will result in additional aging of cellulose in the paper-oil insulation and the potential for the generation of gas bubbles in the bulk oil. Thus, from the point of view of evaluating possible transformer damage due to increased hot spot heating, these thresholds can be considered conservative for a transformer in good operational condition.
- The worst case temperature rise for winding and metallic part (e.g., tie plate) heating should be estimated taking into consideration the construction characteristics of the transformer as they pertain to dc flux offset in the core (e.g., single-phase, shell, 5 and 3-leg three-phase construction).
- Bulk oil temperature due to ambient temperature and transformer loading must be added to the incremental temperature rise caused by hot spot heating. For planning purposes, maximum ambient and loading temperature should be used unless there is a technically justified reason to do otherwise.
- The time series or “waveform” of the reference GMD event in terms of peak amplitude, duration, and frequency of the geoelectric field has an important effect on hot spot heating. Winding and metallic part hot spot heating have different thermal time constants, and their temperature rise will be different if the GIC currents are sustained for 2, 10, or 30 minutes for a given GIC peak amplitude.
- The “effective” GIC in autotransformers (reflecting the different GIC ampere-turns in the common and the series windings) must be used in the assessment. The effective current  $I_{dc,eq}$  in an autotransformer is defined by [2].

$$I_{dc,eq} = I_H + (I_N/3 - I_H) \times V_X/V_H \quad (1)$$

where

$I_H$  is the dc current in the high voltage winding;

$I_N$  is the neutral dc current;

$V_H$  is the root mean square (rms) rated voltage at HV terminals; and

$V_X$  is the rms rated voltage at the LV terminals.

## Transformer Thermal Impact Assessment Process

A simplified thermal assessment may be based on the appropriate tables from the “Screening Criterion for Transformer Thermal Impact Assessment” white paper [3].<sup>4</sup> Each table below provides the peak metallic hot spot temperatures that can be reached for the given GMD event using conservative thermal models. To use each table, one must select the bulk oil temperature and the threshold for metallic hot spot heating, for instance, from reference [1] after allowing for possible de-rating due to transformer condition. If the effective GIC results in higher than threshold temperatures, then the use of a detailed thermal assessment as described below should be carried out.<sup>5</sup>

Effective GIC (A/phase)	Metallic hot spot Temperature (°C)	Effective GIC (A/phase)	Metallic hot spot Temperature (°C)
0	80	100	182
10	107	110	186
20	128	120	190
30	139	130	193
40	148	140	204
50	157	150	213
60	169	160	221
70	170	170	230
75	172	180	234
80	175	190	241
90	179	200	247

<sup>4</sup> Table 1 in the *Screening Criterion for Transformer Thermal Impact Assessment* white paper provides upper bound temperatures for the benchmark GMD event. Table 2 in the *Screening Criterion for Transformer Thermal Impact Assessment* white paper provides upper bound temperatures for the supplemental GMD event.

<sup>5</sup> Effective GIC in the table is the peak GIC(t) for the GMD event being assessed. Peak GIC(t) is not steady-state GIC.

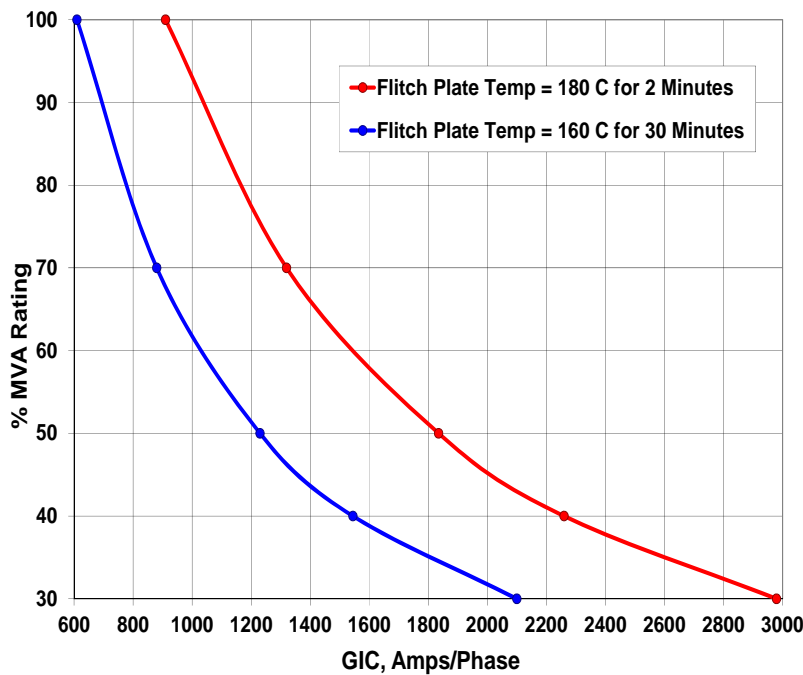
**Table 2: Upper Bound of Peak Metallic Hot Spot Temperatures Calculated Using the Supplemental GMD Event**

Effective GIC (A/phase)	Metallic hot spot Temperature (°C)	Effective GIC (A/phase)	Metallic hot spot Temperature (°C)
0	80	120	188
10	107	130	191
20	124	140	194
30	137	150	198
40	147	160	203
50	156	170	209
60	161	180	214
70	162	190	229
75	165	200	237
80	169	220	248
85	172	230	253
90	177	250	276
100	181	275	298
110	185	300	316

Two different ways to carry out a detailed thermal impact assessment are discussed below. In addition, other approaches and models approved by international standard-setting organizations such as the Institute of Electrical and Electronic Engineers (IEEE) or International Council on Large Electric Systems (CIGRE) may also provide technically justified methods for performing thermal assessments.<sup>6</sup> All thermal assessment methods should be demonstrably equivalent to assessments that use the GMD events associated with TPL-007-2.

1. Transformer manufacturer GIC capability curves. These curves relate permissible peak GIC (obtained by the user from a steady-state GIC calculation) and loading, for a specific transformer. An example of manufacturer capability curves is provided in Figure 2. Presentation details vary between manufacturers, and limited information is available regarding the assumptions used to generate these curves, in particular, the assumed waveshape or duration of the effective GIC. Some manufacturers assume that the waveform of the GIC in the transformer windings is a square pulse of 2, 10, or 30 minutes in duration. In the case of the transformer capability curve shown in Figure 2, a square pulse of 900 A/phase with a duration of 2 minutes would cause the Flitch plate hot spot to reach a temperature of 180°C at full load [5]. While GIC capability curves are relatively simple to use, an amount of engineering judgment is necessary to ascertain which portion of a GIC waveform is equivalent to, for example, a 2 minute pulse. Also, manufacturers generally maintain that in the absence of transformer standards defining thermal duty due to GIC, such capability curves must be developed for every transformer design and vintage.

<sup>6</sup> For example, C57.163-2015 – IEEE Guide for Establishing Power Transformer Capability while under Geomagnetic Disturbances. [4]

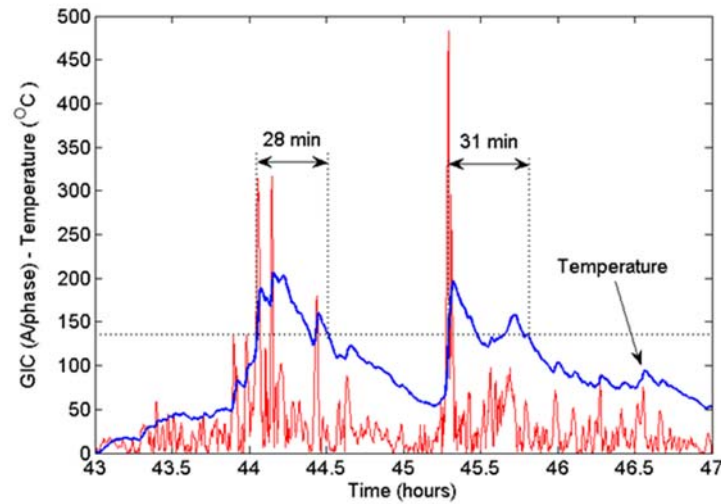


**Figure 2: Sample GIC Manufacturer Capability Curve of a Large Single-Phase Transformer Design using the Flitch Plate Temperature Criteria [5]**

2. Thermal response simulation.<sup>7</sup> The input to this type of simulation is the time series or waveform of effective GIC flowing through a transformer (taking into account the actual configuration of the system), and the result of the simulation is the hot spot temperature (winding or metallic part) time sequence for a given transformer. An example of GIC input and hotspot temperature time series values from [6] are shown in Figure 3. The hot spot thermal transfer functions can be obtained from measurements or calculations provided by transformer manufacturers. Conservative default values can be used (e.g., those provided in [6]) when specific data are not available. Hot spot temperature thresholds shown in Figure 3 are consistent with IEEE Std C57.91-2011 emergency loading hot spot limits. Emergency loading time limit is usually 30 minutes.

<sup>7</sup> Technical details of this methodology can be found in [6].





**Figure 3: Sample Tie Plate Temperature Calculation**

Blue trace is incremental temperature and red trace is the magnitude of the GIC/phase [6]

It is important to reiterate that the characteristics of the time sequence or “waveform” are very important in the assessment of the thermal impact of GIC on transformers. Transformer hot spot heating is not instantaneous. The thermal time constants of transformer windings and metallic parts are typically on the order of minutes to tens of minutes; therefore, hot spot temperatures are heavily dependent on GIC history and rise time, amplitude and duration of GIC in the transformer windings, bulk oil temperature due to loading, ambient temperature and cooling mode.

### Calculation of the GIC Waveform for a Transformer

The following procedure can be used to generate time series GIC data (i.e., GIC(t)) using a software program capable of computing GIC in the steady-state. The steps are as follows:

1. Calculate contribution of GIC due to eastward and northward geoelectric fields for the transformer under consideration; and
2. Scale the GIC contribution according to the reference geoelectric field time series to produce the GIC time series for the transformer under consideration.

Most available GIC-capable software packages can calculate GIC in steady-state in a transformer assuming a uniform eastward geoelectric field of 1 V/km ( $GIC_E$ ) while the northward geoelectric field is zero. Similarly,  $GIC_N$  can be obtained for a uniform northward geoelectric field of 1 V/km while the eastward geoelectric field is zero.  $GIC_E$  and  $GIC_N$  are the normalized GIC contributions for the transformer under consideration.

If the earth conductivity is assumed to be uniform (or laterally uniform) in the transmission system of interest, then the transformer GIC (in A/phase) for any value of  $E_E(t)$  and  $E_N(t)$  can be calculated using (2) [2].

$$GIC(t) = |E(t)| \times \{GIC_E \times \sin(\varphi(t)) + GIC_N \times \cos(\varphi(t))\} \quad (2)$$

where,

$$|E(t)| = \sqrt{E_E^2(t) + E_N^2(t)} \quad (3)$$

$$\varphi(t) = \tan^{-1} \left( \frac{E_E(t)}{E_N(t)} \right) \quad (4)$$

$$GIC(t) = E_E(t) \times GIC_E + E_N(t) \times GIC_N \quad (5)$$

$GIC_N$  is the effective GIC due to a northward geoelectric field of 1 V/km, and  $GIC_E$  is the effective GIC due to an eastward geoelectric field of 1 V/km. The units for  $GIC_N$  and  $GIC_E$  are A/phase per V/km).

The geoelectric field time series  $E_N(t)$  and  $E_E(t)$  is obtained, for instance, from the reference geomagnetic field time series (from [7] and/or [8]) after the appropriate geomagnetic latitude scaling factor  $\alpha$  is applied.<sup>8</sup> The reference geoelectric field time series is calculated using the reference earth model. When using this geoelectric field time series where a different earth model is applicable, it should be scaled with the appropriate conductivity scaling factor  $\beta$ .<sup>9</sup> Alternatively, the geoelectric field can be calculated from the reference geomagnetic field time series after the appropriate geomagnetic latitude scaling factor  $\alpha$  is applied and the appropriate earth model is used. In such case, the conductivity scaling factor  $\beta$  is not applied because it is already accounted for by the use of the appropriate earth model.

Applying (5) to each point in  $E_N(t)$  and  $E_E(t)$  results in  $GIC(t)$ .

### **GIC(t) Calculation Example**

Let us assume that from the steady-state solution, the effective GIC in this transformer is  $GIC_E = -20$  A/phase if  $E_N=0$ ,  $E_E=1$  V/km and  $GIC_N = 26$  A/phase if  $E_N=1$  V/km,  $E_E=0$ . Let us also assume the geomagnetic field time

<sup>8</sup> The geomagnetic factor  $\alpha$  is described in [2] and is used to scale the geomagnetic field according to geomagnetic latitude. The lower the geomagnetic latitude (closer to the equator), the lower the amplitude of the geomagnetic field.

<sup>9</sup> The conductivity scaling factor  $\beta$  is described in [2], and is used to scale the geoelectric field according to the conductivity of different physiographic regions. Lower conductivity results in higher  $\beta$  scaling factors.

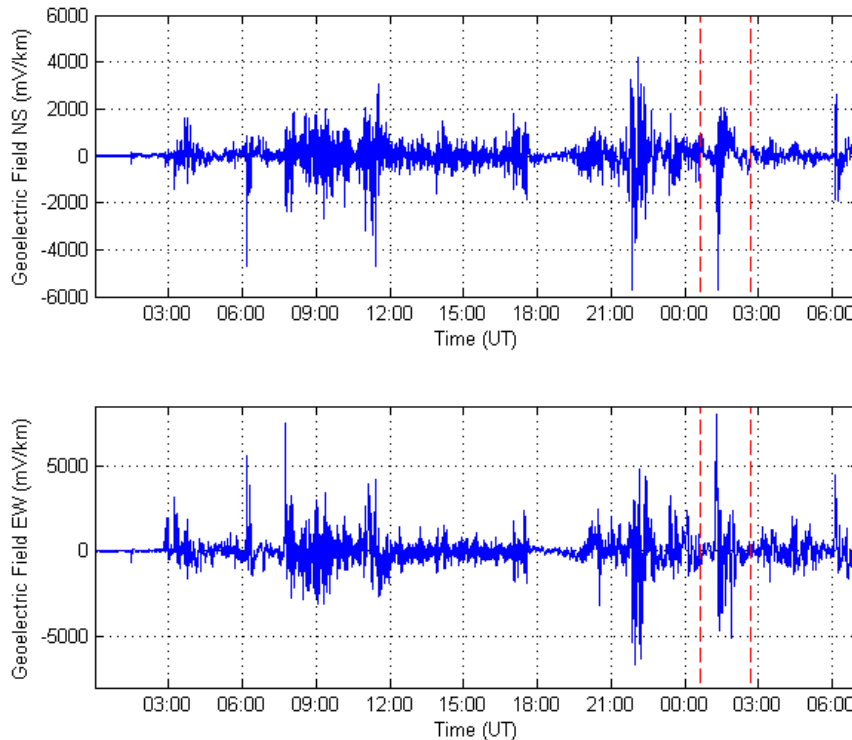
series corresponds to a geomagnetic latitude where  $\alpha = 1$  and that the earth conductivity corresponds to the reference earth model in [7]. The resulting geoelectric field time series is shown in Figure 4. Therefore:

$$GIC(t) = E_E(t) \times GIC_E + E_N(t) \times GIC_N \text{ (A/Phase)} \quad (6)$$

$$GIC(t) = -E_E(t) \times 20 + E_N(t) \times 26 \text{ (A/Phase)} \quad (7)$$

The resulting GIC waveform  $GIC(t)$  is shown in Figures 5 and 6 and can subsequently be used for thermal analysis.

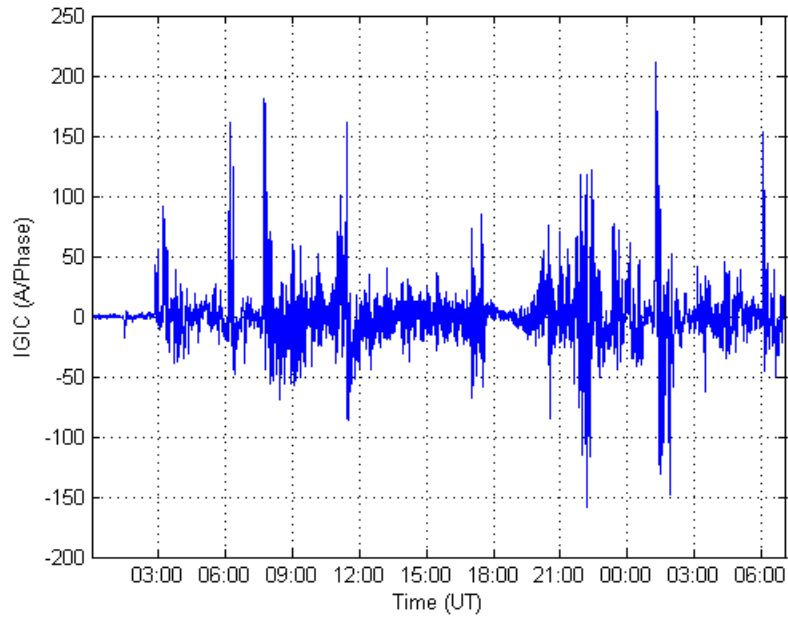
It should be emphasized that even for the same reference event, the  $GIC(t)$  waveform in every transformer will be different, depending on the location within the system and the number and orientation of the circuits connecting to the transformer station. Assuming a single generic  $GIC(t)$  waveform to test all transformers is incorrect.



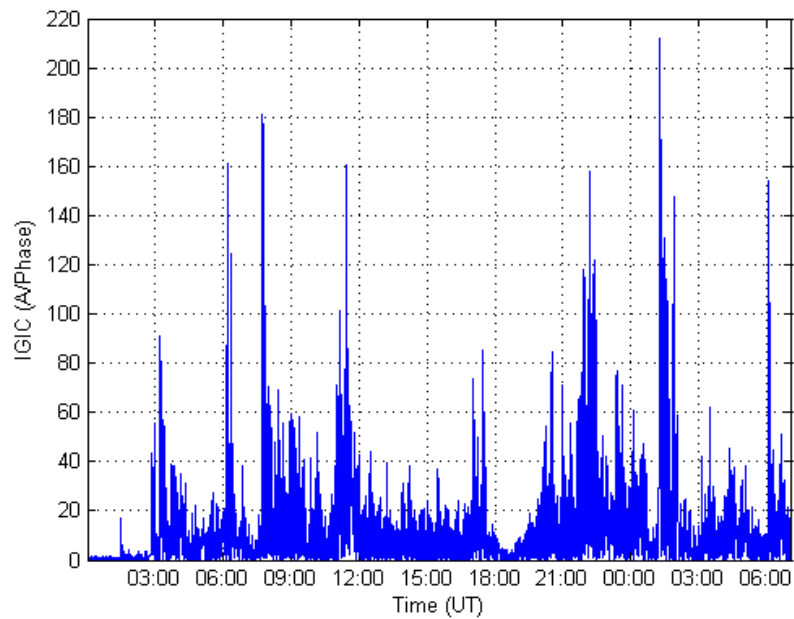
**Figure 4: Calculated Geoelectric Field  $E_N(t)$  and  $E_E(t)$  Assuming  $\alpha=1$  and  $\beta=1$  (Reference Earth Model)**

Zoom area for subsequent graphs is highlighted

Dashed lines approximately show the close-up area for subsequent Figures



**Figure 5: Calculated GIC(t) Assuming  $\alpha=1$  and  $\beta=1$  Reference Earth Model**



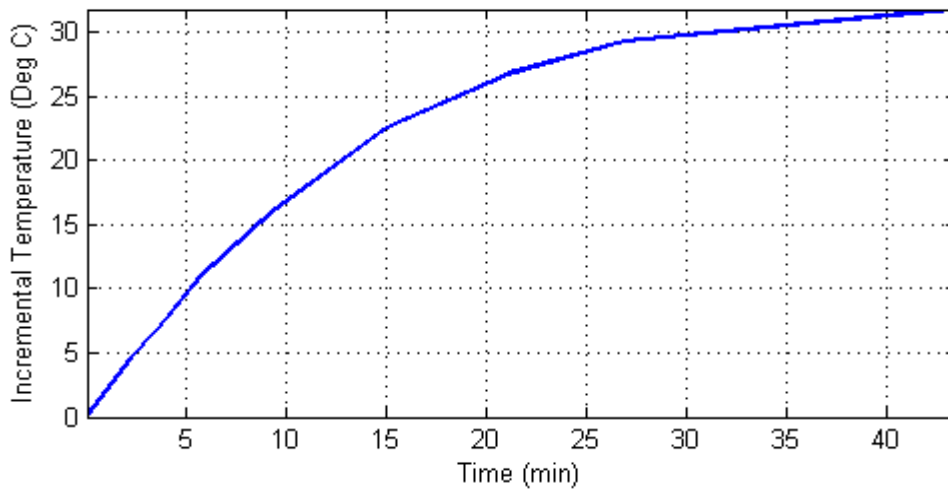
**Figure 6: Calculated Magnitude of GIC(t) Assuming  $\alpha=1$  and  $\beta=1$  Reference Earth Model**

**Transformer Thermal Assessment Examples**

There are two basic ways to carry out a transformer thermal analysis once the GIC time series  $GIC(t)$  is known for a given transformer: 1) calculating the thermal response as a function of time; and 2) using manufacturer’s capability curves.

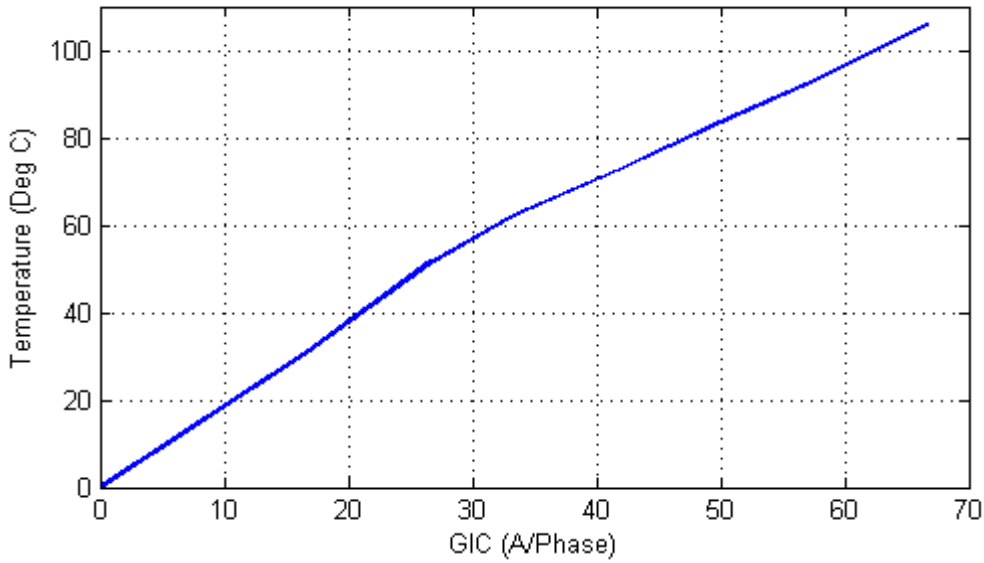
***Example 1: Calculating thermal response as a function of time using a thermal response tool***

The thermal step response of the transformer can be obtained for both winding and metallic part hot spots from: 1) measurements; 2) manufacturer’s calculations; or 3) generic published values. Figure 7 shows the measured metallic hot spot thermal response to a dc step of 16.67 A/phase of the top yoke clamp from [9] that will be used in this example. Figure 8 shows the measured incremental temperature rise (asymptotic response) of the same hot spot to long duration GIC steps.<sup>10</sup>



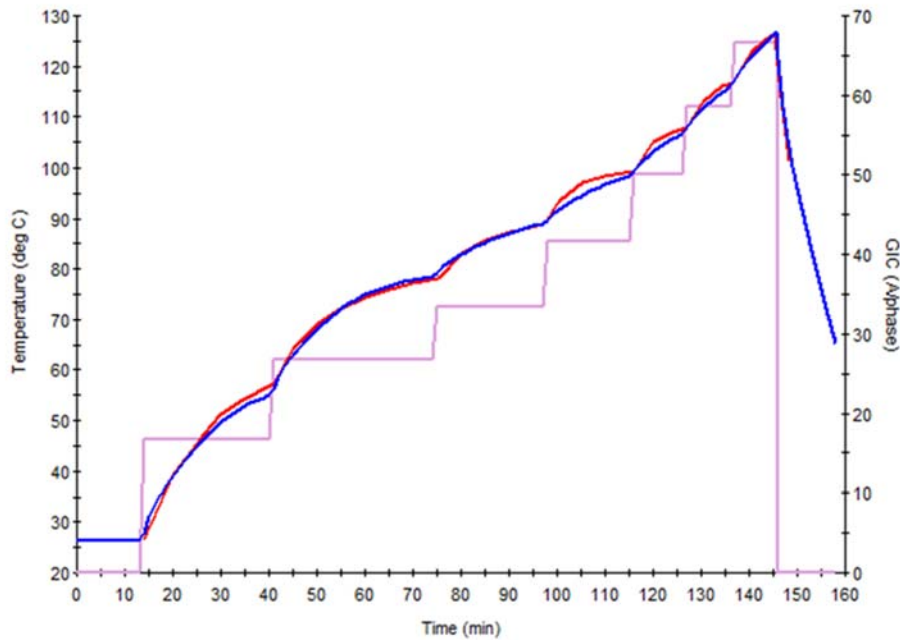
**Figure 7: Thermal Step Response to a 16.67 Amperes per Phase dc Step  
 Metallic hot spot heating**

<sup>10</sup> Heating of bulk oil due to the hot spot temperature increase is not included in the asymptotic response because the time constant of bulk oil heating is at least an order of magnitude larger than the time constants of hot spot heating.



**Figure 8: Asymptotic Thermal Step Response**  
 Metallic hot spot heating

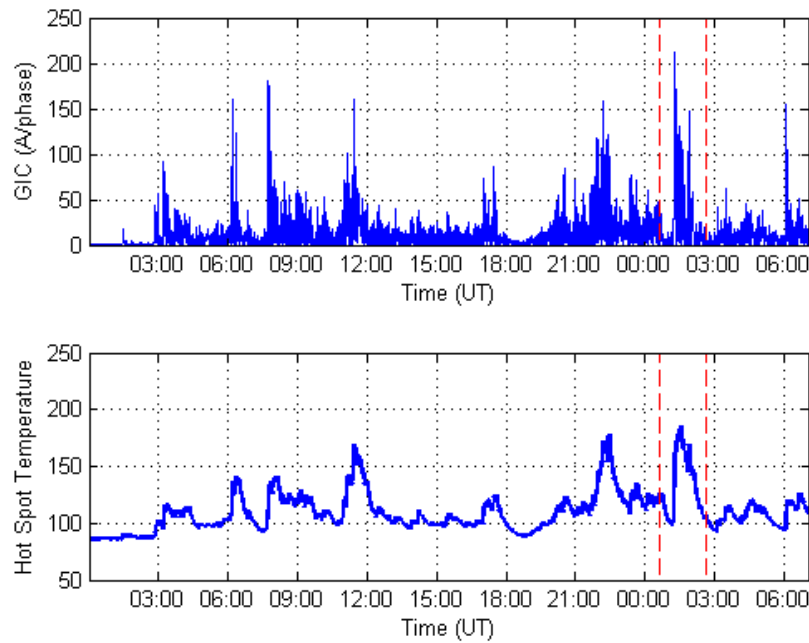
The step response in Figure 7 was obtained from the first GIC step of the tests carried out in [6]. The asymptotic thermal response in Figure 8 was obtained from the final or near-final temperature values after each subsequent GIC step. Figure 9 shows a comparison between measured temperatures and the calculated temperatures using the thermal response model used in the rest of this discussion.



**Figure 9: Comparison of measured temperatures (red) and simulation results (blue)**  
 Injected current is represented by magenta

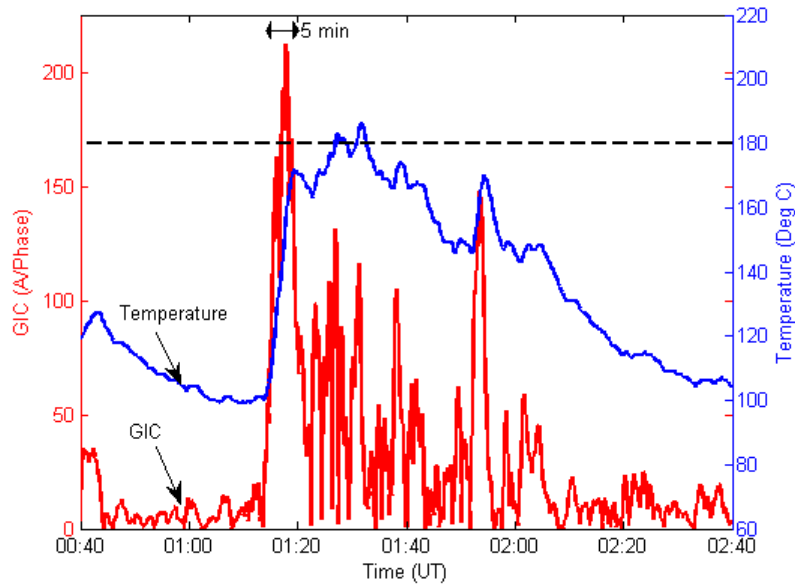
To obtain the thermal response of the transformer to a GIC waveform such as the one in Figure 6, a thermal response model is required. To create a thermal response model, the measured or manufacturer-calculated transformer thermal step responses (winding and metallic part) for various GIC levels are required. The GIC(t) time series or waveform is then applied to the thermal model to obtain the incremental temperature rise as a function of time  $\theta(t)$  for the GIC(t) waveform. The total temperature is calculated by adding the oil temperature, for example, at full load.

Figure 10 illustrates the calculated GIC(t) and the corresponding metallic hot spot temperature time series  $\theta(t)$ . Figure 11 illustrates a close-up view of the peak transformer temperatures calculated in this example.



**Figure 10: Magnitude of GIC(t) and Metallic Hot Spot Temperature  $\theta(t)$  Assuming Full Load Oil Temperature of 85.3°C (40°C ambient)**

Dashed lines approximately show the close-up area for subsequent figures



**Figure 11: Close-up of Metallic Hot Spot Temperature Assuming a Full Load**  
 Blue trace is  $\theta(t)$  Red trace is  $GIC(t)$

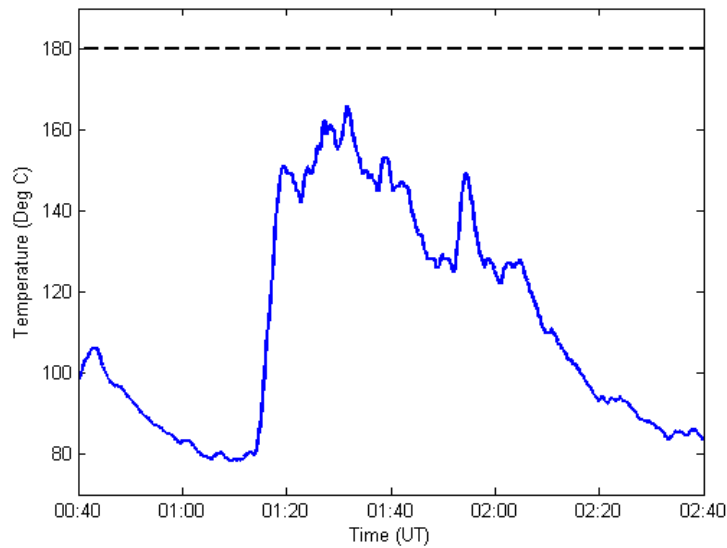
In this example, the IEEE Std C57.91-2011 emergency loading hot spot threshold of 200°C for metallic hot spot heating is not exceeded. Peak temperature is 186°C. The IEEE standard is silent as to whether the temperature can be higher than 200°C for less than 30 minutes. Manufacturers can provide guidance on individual transformer capability.

It is not unusual to use a lower temperature threshold of 180°C to account for calculation and data margins, as well as transformer age and condition. Figure 11 shows that 180°C will be exceeded for 5 minutes.

At 75% loading, the initial temperature is 64.6°C rather than 85.3°C, and the hot spot temperature peak is 165°C, well below the 180°C threshold (see Figure 12).

If a conservative threshold of 160°C were used to account for the age and condition of the transformer, then the full load limits would be exceeded for approximately 22 minutes.

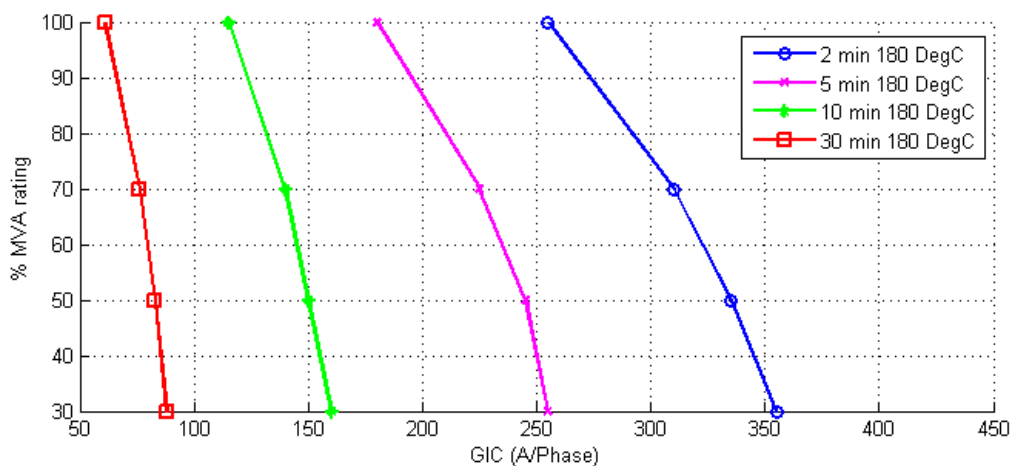




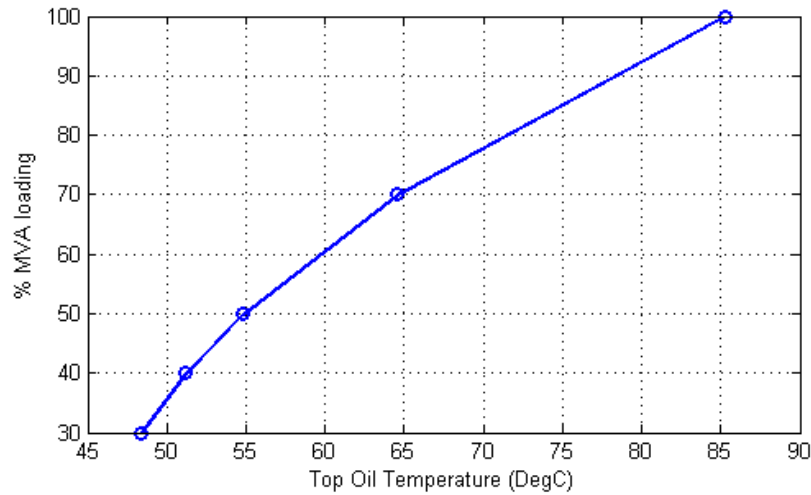
**Figure 12: Close-up of Metallic Hot Spot Temperature Assuming a 75% Load**  
Oil temperature of 64.5°C

**Example 2: Using a Manufacturer's Capability Curves**

The capability curves used in this example are shown in Figure 13. To maintain consistency with the previous example, these particular capability curves have been reconstructed from the thermal step response shown in Figures 7 and 8, and the simplified loading curve shown in Figure 14 (calculated using formulas from IEEE Std C57.91-2011).



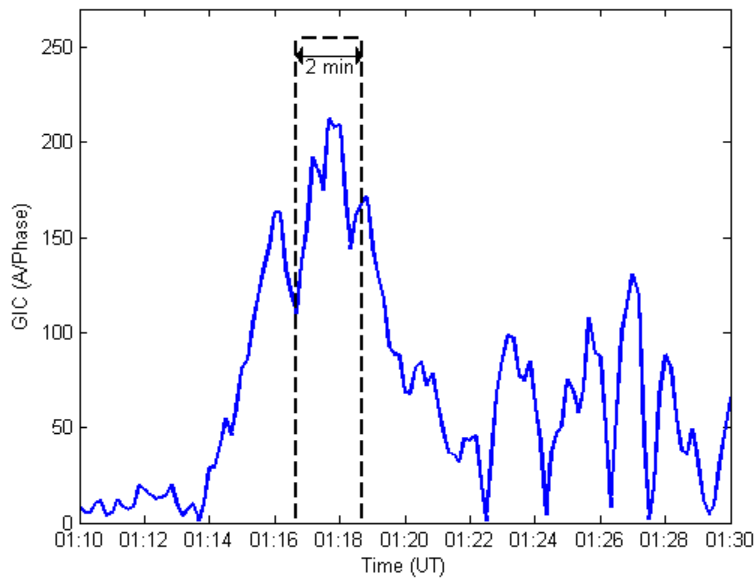
**Figure 13: Capability Curve of a Transformer Based on the Thermal Response Shown in Figures 8 and 9**



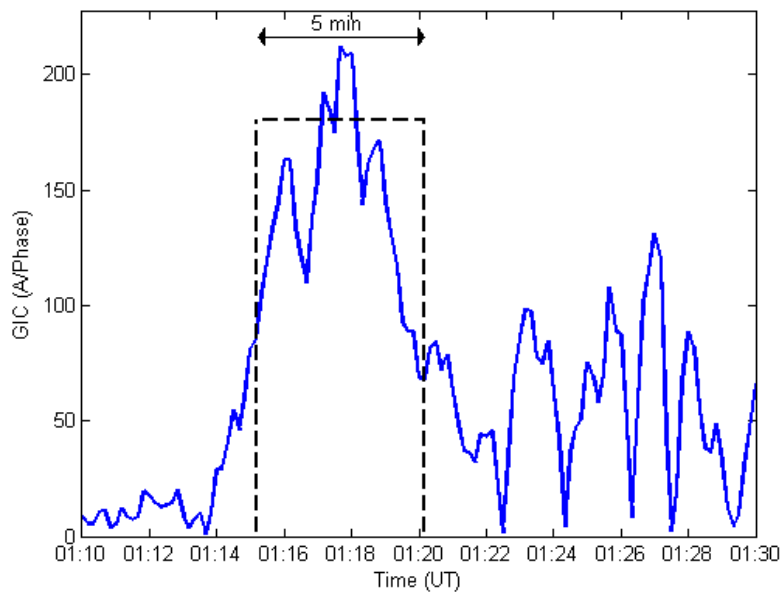
**Figure 14: Simplified Loading Curve Assuming 40°C Ambient Temperature**

The basic notion behind the use of capability curves is to compare the calculated GIC in a transformer with the limits at different GIC pulse widths. A narrow GIC pulse has a higher limit than a longer duration or wider one. If the calculated GIC and assumed pulse width falls below the appropriate pulse width curve, then the transformer is within its capability.

To use these curves, it is necessary to estimate an equivalent square pulse that matches the waveform of GIC(t), generally at a GIC(t) peak. Figure 15 shows a close-up of the GIC near its highest peak superimposed to a 255 Amperes per phase, 2 minute pulse at 100% loading from Figure 13. Since a narrow 2-minute pulse is not representative of GIC(t) in this case, a 5 minute pulse with an amplitude of 180 A/phase at 100% loading has been superimposed on Figure 16. It should be noted that a 255 A/phase, 2 minute pulse is equivalent to a 180 A/phase 5 minute pulse from the point of view of transformer capability. Deciding what GIC pulse is equivalent to the portion of GIC(t) under consideration is a matter of engineering judgment.



**Figure 15: Close-up of GIC(t) and a 2 minute 255 A/phase GIC pulse at full load**



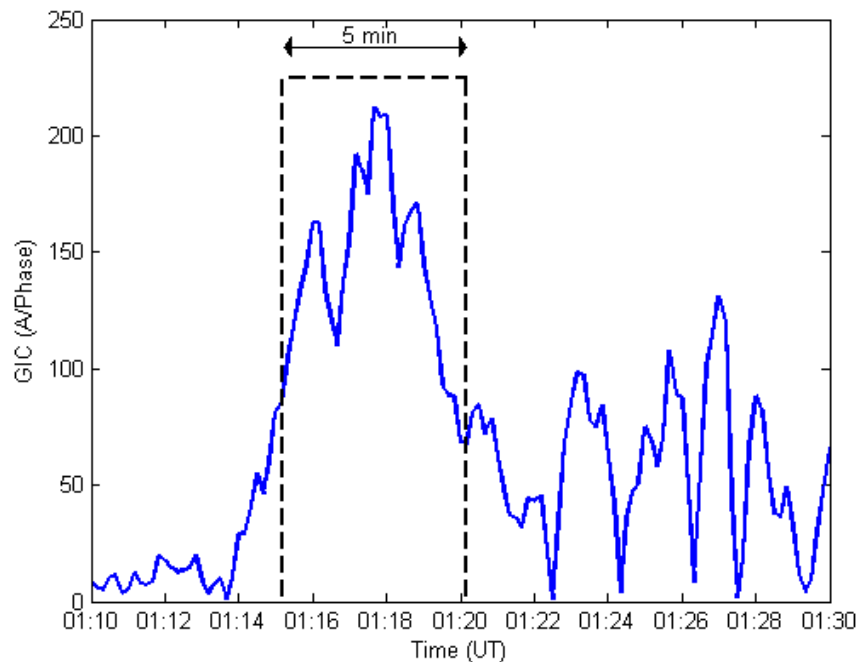
**Figure 16: Close-up of GIC(t) and a Five Minute 180 A/phase GIC Pulse at Full Load**

When using a capability curve, it should be understood that the curve is derived assuming that there is no hot spot heating due to prior GIC at the time the GIC pulse occurs (only an initial temperature due to loading). Therefore, in addition to estimating the equivalent pulse that matches GIC(t), prior metallic hot

spot heating must be accounted for. From these considerations, it is unclear whether the capability curves would be exceeded at full load with a 180°C threshold in this example.

At 70% loading, the two and five minute pulses from Figure 13 would have amplitudes of 310 and 225 A/phase, respectively. The 5 minute pulse is illustrated in Figure 17. In this case, judgment is also required to assess if the GIC(t) is within the capability curve for 70% loading. In general, capability curves are easier to use when GIC(t) is substantially above, or clearly below the GIC thresholds for a given pulse duration.

If a conservative threshold of 160°C were used to account for the age and condition of the transformer, then a new set of capability curves would be required.



**Figure 17: Close-up of GIC(t) and a 5 Minute 225 A/phase GIC Pulse Assuming 70% Load**

## References

- [1] "IEEE Guide for Loading Mineral-Oil-Immersed Transformers and Step-Voltage Regulators." IEEE Std C57.91-2011 (Revision of IEEE Std C57.91-1995). March 7, 2012.
- [2] "Application Guide: Computing Geomagnetically-Induced Current in the Bulk-Power System," NERC. December 2013. Available at: [http://www.nerc.com/comm/PC/Geomagnetic%20Disturbance%20Task%20Force%20GMDTF%202013/GIC%20Application%20Guide%202013\\_approved.pdf](http://www.nerc.com/comm/PC/Geomagnetic%20Disturbance%20Task%20Force%20GMDTF%202013/GIC%20Application%20Guide%202013_approved.pdf).
- [3] "Screening Criterion for Transformer Thermal Impact Assessment." Developed by the Project 2013-03 (Geomagnetic Disturbance) standard drafting team. October 2017. Available at: <http://www.nerc.com/pa/Stand/Pages/Project-2013-03-Geomagnetic-Disturbance-Mitigation.aspx>.
- [4] "IEEE Guide for Establishing Power Transformer Capability while under Geomagnetic Disturbances." IEEE Std C57.163-2015. October 26, 2015.
- [5] Girgis, R.; Vedante, K. "Methodology for evaluating the impact of GIC and GIC capability of power transformer designs." IEEE Power and Energy Society 2013 General Meeting Proceedings. Vancouver, Canada.
- [6] Marti, L.; Rezaei-Zare, A.; and Narang, A. "Simulation of Transformer Hotspot Heating due to Geomagnetically Induced Currents." IEEE Transactions on Power Delivery, Vol.28, No.1. pp 320-327. January 2013.
- [7] "Benchmark Geomagnetic Disturbance Event Description" white paper. Developed by the Project 2013-03 (Geomagnetic Disturbance) standard drafting team. May 2016. Available at: <http://www.nerc.com/pa/Stand/Pages/Project-2013-03-Geomagnetic-Disturbance-Mitigation.aspx>.
- [8] "Supplemental Geomagnetic Disturbance Event Description" white paper. Developed by the Project 2013-03 (Geomagnetic Disturbance) standard drafting team. October 2017. Available at: <http://www.nerc.com/pa/Stand/Pages/Project-2013-03-Geomagnetic-Disturbance-Mitigation.aspx>.
- [9] Lahtinen, M; and Elovaara, J. "GIC occurrences and GIC test for 400 kV system transformer." IEEE Transactions on Power Delivery, Vol. 17, No. 2. pp 555-561. April 2002.

**Exhibit H**

**Screening Criterion for Transformer Thermal Impact Assessment**

**White Paper**

# Screening Criterion for Transformer Thermal Impact Assessment White Paper

## TPL-007-2 Transmission System Planned Performance for Geomagnetic Disturbance Events

### Summary

Proposed TPL-007-2 includes requirements for entities to perform two types of geomagnetic disturbance (GMD) Vulnerability Assessments to evaluate the potential impacts of GMD events on the Bulk Electric System (BES):

- The benchmark GMD Vulnerability Assessment is based on the benchmark GMD event associated with TPL-007-1 which standard was approved by the Federal Energy Regulatory Commission (FERC) in Order No. 830 in September 2016. The benchmark GMD event is derived from spatially-averaged geoelectric field values to address potential wide-area effects that could be caused by a severe 1-in-100 year GMD event.<sup>1</sup>
- The supplemental GMD Vulnerability Assessment, based on the supplemental GMD event, is used by entities to evaluate risks that localized peaks in geomagnetic field during a severe GMD event "could potentially affect the reliable operation of the Bulk-Power System".<sup>2</sup> Localized enhancements of geomagnetic field can result in geoelectric field values above the spatially-averaged benchmark in a local area.

The standard requires transformer thermal impact assessments to be performed on BES power transformers with high side, wye-grounded windings with terminal voltage greater than 200 kV. Identified BES transformers must undergo a thermal impact assessment if the maximum effective geomagnetically-induced current (GIC) in the transformer is equal to or greater than:

- 75 A per phase for the benchmark GMD event
- 85 A per phase for the supplemental GMD event

Based on published power transformer measurement data as described below, the respective screening criteria are conservative and, although derived from measurements in single-phase units, are applicable to transformers with all core types (e.g., three-limb, three-phase).

<sup>1</sup> See *Benchmark Geomagnetic Disturbance Event Description* white paper, May 12, 2016. Filed by NERC in Docket No. RM15-11 on June 28, 2016.

<sup>2</sup> See Order No. 830, P. 47. In Order No. 830, FERC directed NERC to develop modifications to the benchmark GMD event, included in TPL-007-1, such that assessments would not be based solely on spatially averaged data. The characteristics of a GMD event for this assessment are in the Supplemental GMD Event Description white paper.

Outside of the differing screening criteria, the only difference between the thermal impact assessment for the benchmark GMD event and the supplemental GMD event is that a different waveform is used, therefore peak metallic hot spot temperatures are slightly different for a given GIC in the transformer.

### Justification for the Benchmark Screening Criterion

Applicable entities are required to carry out a thermal assessment with  $GIC(t)$  calculated using the benchmark GMD event geomagnetic field time series or waveform for effective GIC values above a screening threshold. The calculated  $GIC(t)$  for every transformer will be different because the length and orientation of transmission circuits connected to each transformer will be different even if the geoelectric field is assumed to be uniform. However, for a given thermal model and maximum effective GIC there are upper and lower bounds for the peak hot spot temperatures. These are shown in Figure 1 using three available thermal models based on direct temperature measurements.

The results shown in Figure 1 summarize the peak metallic hot spot temperatures when  $GIC(t)$  is calculated using (1), and systematically varying  $GIC_E$  and  $GIC_N$  to account for all possible orientation of circuits connected to a transformer. The transformer GIC (in A/phase) for any value of  $E_E(t)$  and  $E_N(t)$  can be calculated using equation (1) from reference [1].

$$GIC(t) = |E(t)| \times \{GIC_E \times \sin(\varphi(t)) + GIC_N \times \cos(\varphi(t))\} \quad (1)$$

where

$$|E(t)| = \sqrt{E_N^2(t) + E_E^2(t)} \quad (2)$$

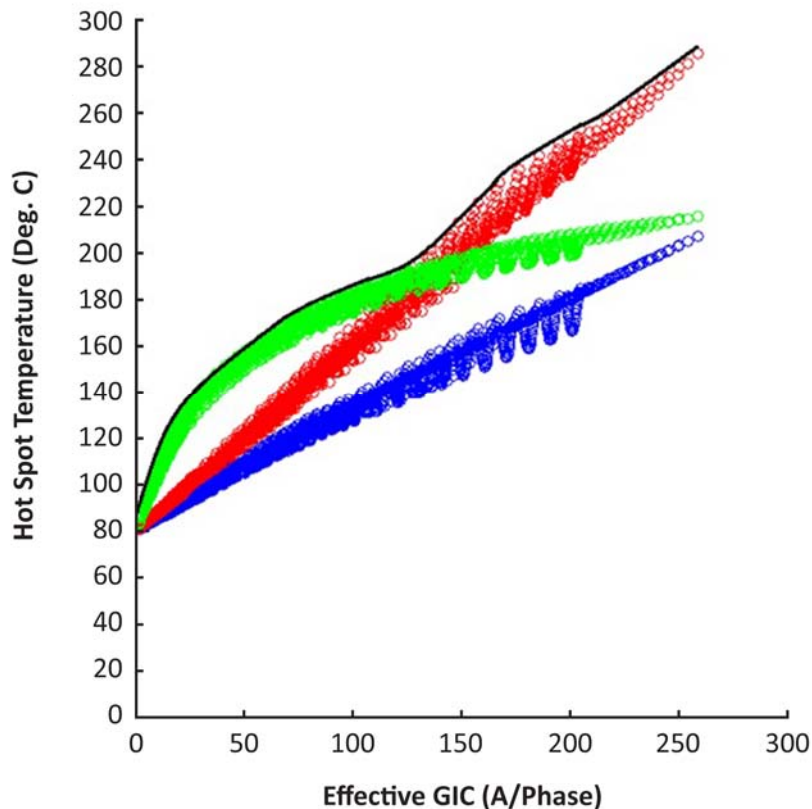
$$\varphi(t) = \tan^{-1} \left( \frac{E_E(t)}{E_N(t)} \right) \quad (3)$$

$$GIC(t) = E_E(t) \times GIC_E + E_N(t) \times GIC_N \quad (4)$$

$GIC_N$  is the effective GIC due to a northward geoelectric field of 1 V/km, and  $GIC_E$  is the effective GIC due to an eastward geoelectric field of 1 V/km. The units for  $GIC_N$  and  $GIC_E$  are A/phase per V/km.

It should be emphasized that with the thermal models used and the benchmark GMD event geomagnetic field waveform, peak metallic hot spot temperatures will lie below the envelope shown in black in Figure 1. The x-axis in Figure 1 corresponds to the absolute value of peak  $GIC(t)$ . Effective maximum GIC for a transformer corresponds to a worst-case geoelectric field orientation, which is network-specific. Figure 1 represents a possible range, not the specific thermal response for a given effective GIC and orientation.





**Figure 1: Metallic hot spot temperatures calculated using the benchmark GMD event**

Red: SVC coupling transformer model [2] Blue: Fingrid model [3] Green: Autotransformer model [4]

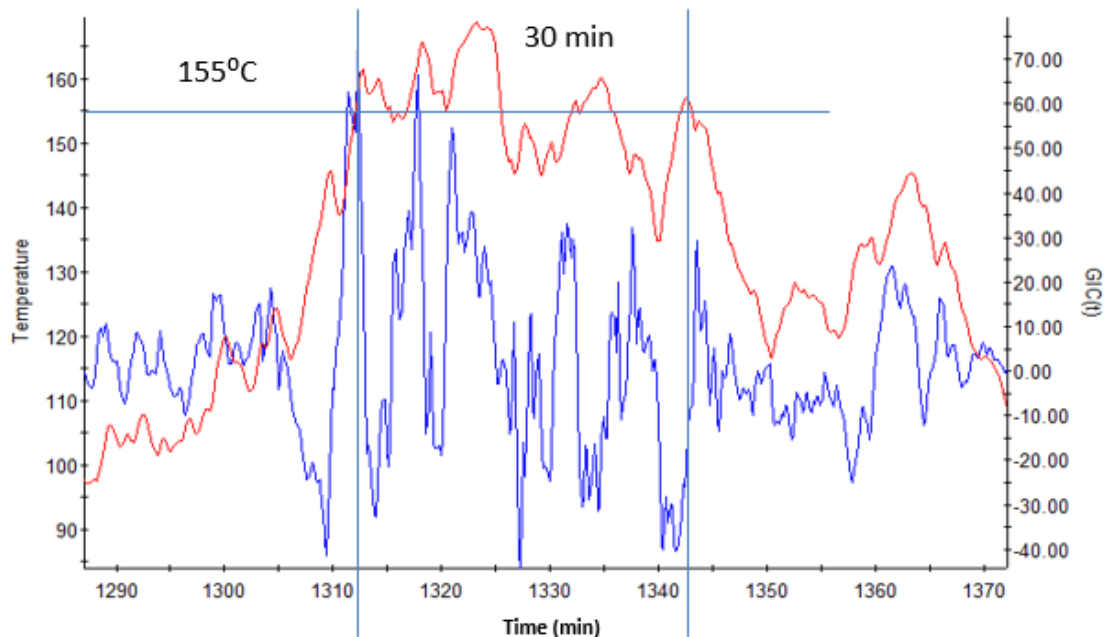
Consequently, with the most conservative thermal models known at this point in time, the peak metallic hot spot temperature obtained with the benchmark GMD event waveform assuming an effective GIC magnitude of 75 A per phase will result in a peak temperature between 160°C and 172°C when the bulk oil temperature is 80°C (full load bulk oil temperature). The upper boundary of 172°C remains well below the metallic hot spot 200°C threshold for short-time emergency loading suggested in IEEE Std C57.91-2011 – Guide for Loading Mineral-Oil-Immersed Transformers and Step-Voltage Regulators [5].

The selection of the 75 A per phase screening threshold is based on the following considerations:

- A thermal assessment, which uses the most conservative thermal models known to date, indicates that a GIC of 75A will not result in peak metallic hot spot temperatures above 172°C. Transformer thermal assessments should not be required by Reliability Standards when results will fall well below IEEE Std C57.91-2011 limits.

- Applicable entities may choose to carry out a thermal assessment when the effective GIC is below 75 A per phase to take into account the age or condition of specific transformers where IEEE Std C57.91- 2011 limits could be assumed to be lower than 200°C. Refer to IEEE Standard C57.163-2015 Guide for Establishing Power Transformer Capability while under Geomagnetic Disturbances for additional information [6].
- The models used to determine the 75 A per phase screening threshold are known to be conservative at higher values of effective GIC, especially the SVC coupling transformer model in [2].
- Thermal models in peer-reviewed technical literature, especially those calculated models without experimental validation, are less conservative than the models used to determine the screening threshold. Therefore, a technically-justified thermal assessment for effective GIC below 75 A per phase using the benchmark GMD event geomagnetic field waveform will always result in a “pass” on the basis of the state of the knowledge at this point in time.
- Based on simulations, the 75 A per phase screening threshold will result in a maximum instantaneous peak hot spot temperature of 172°C. However, IEEE Std C57.91-2011 limits assume short term emergency operation (typically 30 minutes). As illustrated in Figure 2, simulations of the 75 A per phase screening threshold result in 30-minute duration hot spot temperatures of about 155°C. The threshold provides an added measure of conservatism in not taking into account the duration of hot spot temperatures.
- The models used in the determination of the threshold are conservative but technically justified.
- Winding hot spots are not the limiting factor in terms of hot spots due to half-cycle saturation, therefore the screening criterion is focused on metallic part hot spots only.

The 75 A per phase screening threshold was determined using single-phase transformers, but is being applied as a screening criterion for all types of transformer construction. While it is known that some transformer types such as three-limb, three-phase transformers are intrinsically less susceptible to GIC, it is not known by how much, on the basis of experimentally-supported models.



**Figure 2: Metallic hot spot temperatures calculated using the benchmark GMD event**

Red: metallic hot spot temperature

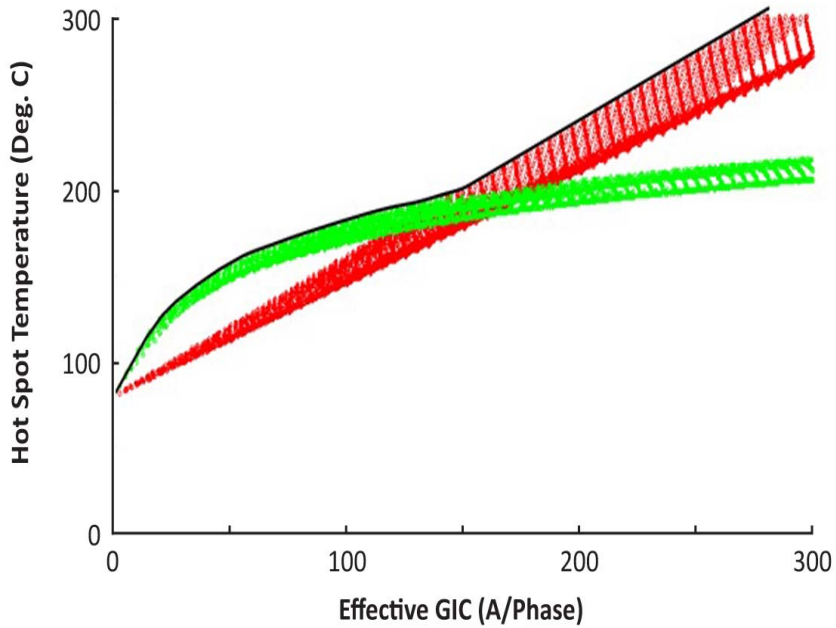
Blue: GIC(t) that produces the maximum hot spot temperature with peak GIC(t) scaled to 75 A/phase

## Justification for the Supplemental Screening Criterion

As in the case for the benchmark GMD event discussed above, applicable entities are required to carry out thermal assessments on their BES power transformers when the effective GIC values are above a screening threshold. GIC(t) for supplemental thermal assessments is calculated using the supplemental GMD event geomagnetic field time series or waveform.

Using the supplemental GMD event waveform, a thermal analysis was completed for the two transformers that were limiting for the benchmark waveform. The results are shown in Figure 3. Peak metallic hot spot temperatures for the supplemental GMD event will lie below the envelope shown by the black line trace in Figure 3. Because the supplemental waveform has a sharper peak, the peak metallic hot spot temperatures are slightly lower than those associated with the benchmark waveform. Applying the most conservative thermal models known at this point in time, the peak metallic hot spot temperature obtained with the supplemental GMD event waveform assuming an effective GIC magnitude of 85 A per phase will result in a peak temperature of 172°C when the bulk oil temperature is 80°C (full load bulk oil temperature).<sup>3</sup> Thus, 85 A per phase is the screening level for the supplemental waveform.

<sup>3</sup> The temperature 172°C was selected as the screening criteria for the benchmark waveform as described in the preceding section.



**Figure 3: Metallic hot spot temperatures calculated using the supplemental GMD event**  
Red: SVC coupling transformer model [2] Green: Autotransformer model [4]

## Appendix I - Transformer Thermal Models Used in the Development of the Screening Criteria

The envelope used for thermal screening (Figure 1) is derived from two thermal models. The first is based on laboratory measurements carried out on 500/16.5 kV 400 MVA single-phase Static Var Compensator (SVC) coupling transformer [2]. Temperature measurements were carried out at relatively small values of GIC (see Figure I-1). The asymptotic thermal response for this model is the linear extrapolation of the known measurement values. Although the near-linear behavior of the asymptotic thermal response is consistent with the measurements made on a Fingrid 400 kV 400 MVA five-leg core-type fully-wound transformer [3] (see Figures I-2 and I-3), the extrapolation from low values of GIC is very conservative, but reasonable for screening purposes.

The second transformer model is based on a combination of measurements and modeling for a 400 kV 400 MVA single-phase core-type autotransformer [4] (see Figures I-4 and I-5). The asymptotic thermal behavior of this transformer shows a “down-turn” at high values of GIC as the tie plate increasingly saturates but relatively high temperatures for lower values of GIC. The hot spot temperatures are higher than for the two other models for GIC less than 125 A per phase.

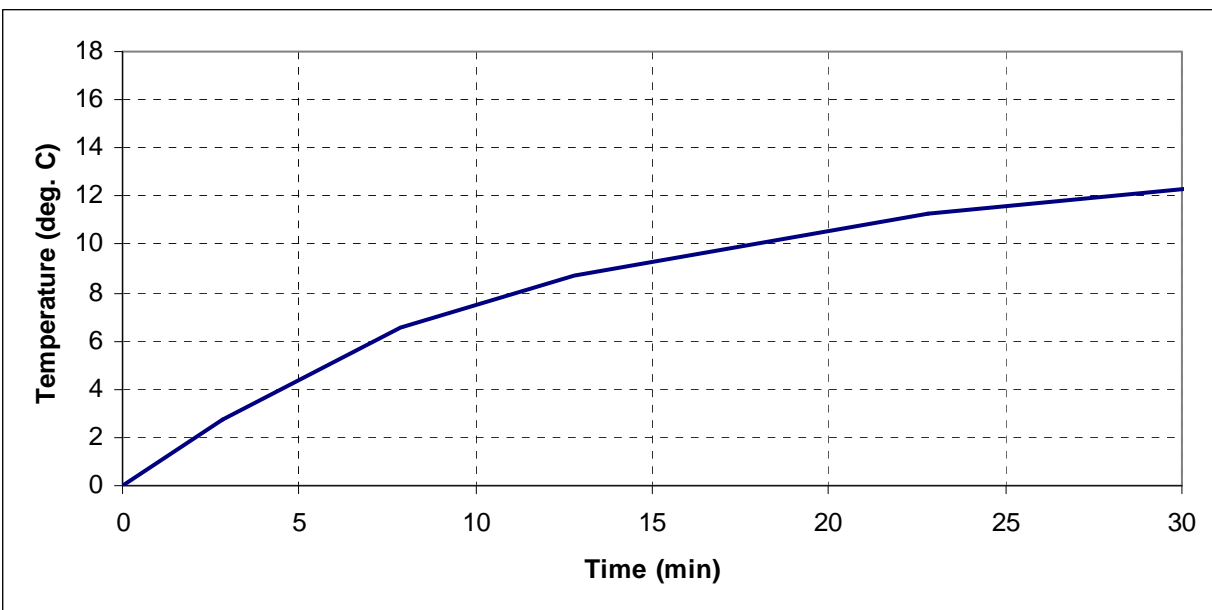


Figure I-1: Thermal step response of the tie plate of a 500 kV 400 MVA single-phase SVC coupling transformer to a 5 A per phase dc step

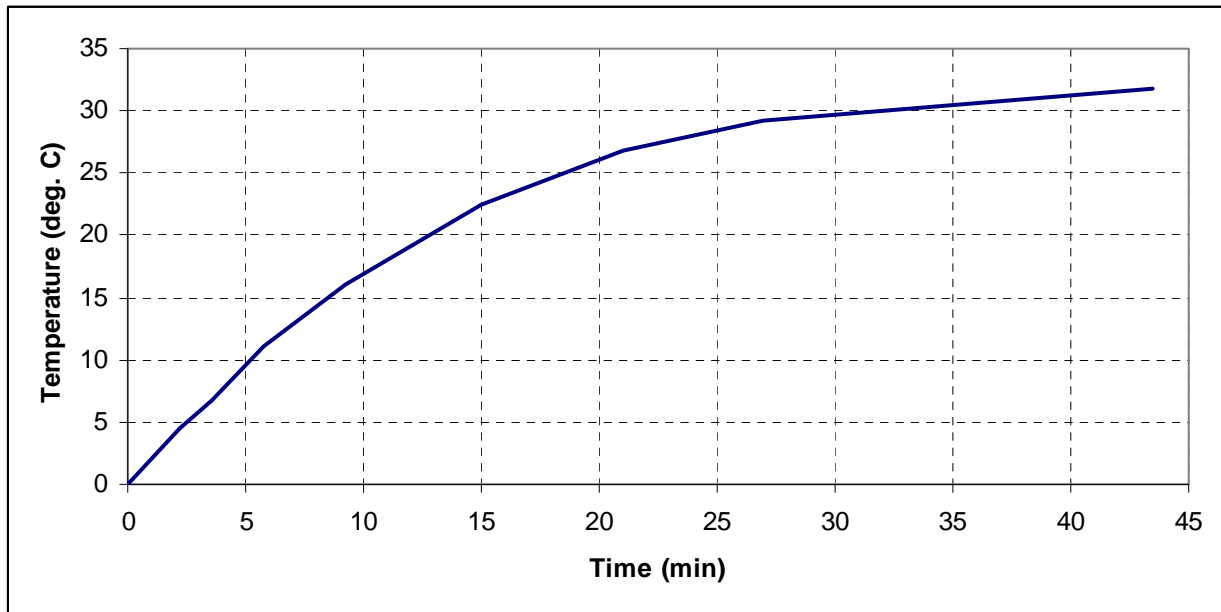


Figure I-2: Step thermal response of the top yoke clamp of a 400 kV 400 MVA five-leg core-type fully-wound transformer to a 16.67 A per phase dc step

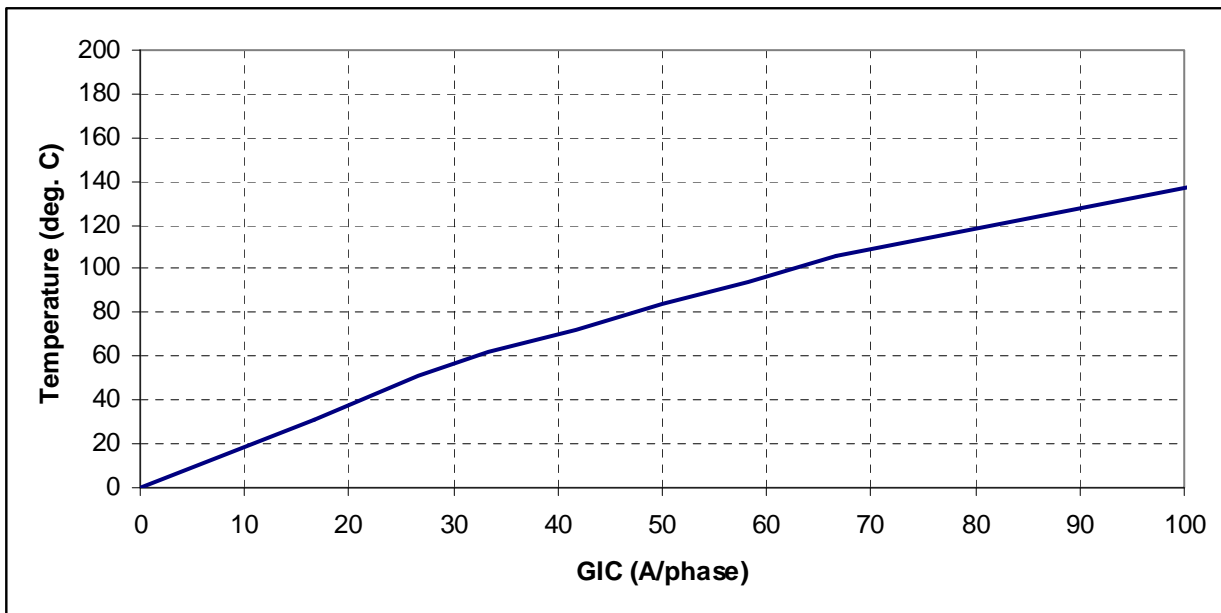


Figure I-3: Asymptotic thermal response of the top yoke clamp of a 400 kV 400 MVA five-leg core-type fully-wound transformer

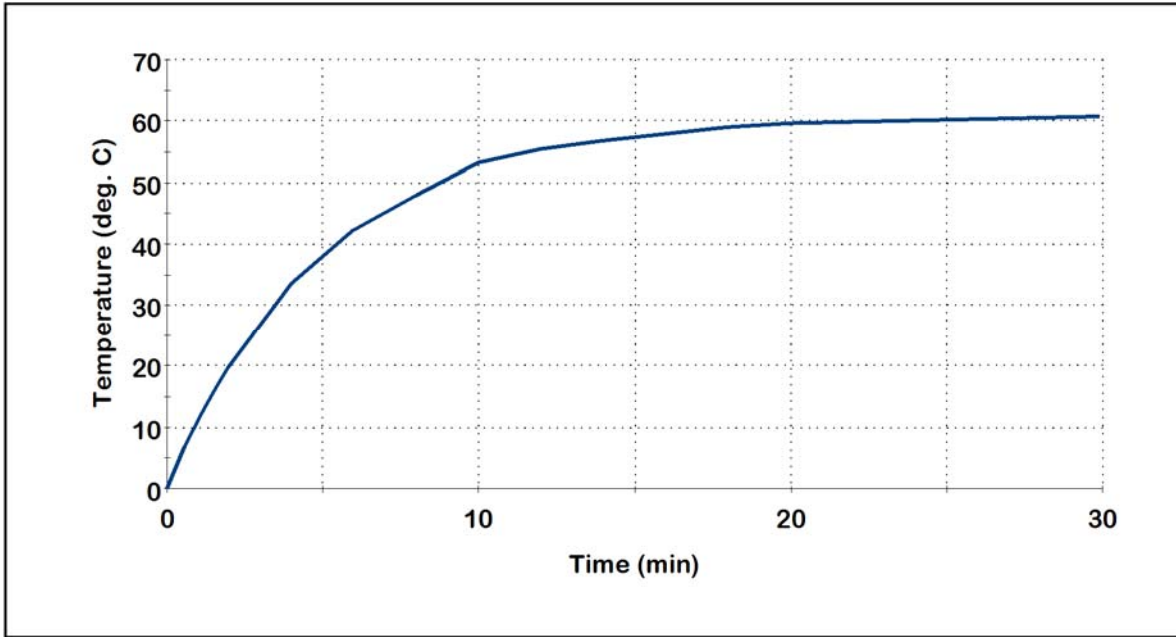


Figure I-4: Step thermal response of the tie plate of a 400 kV 400 MVA single-phase core-type autotransformer to a 10 A per phase dc step

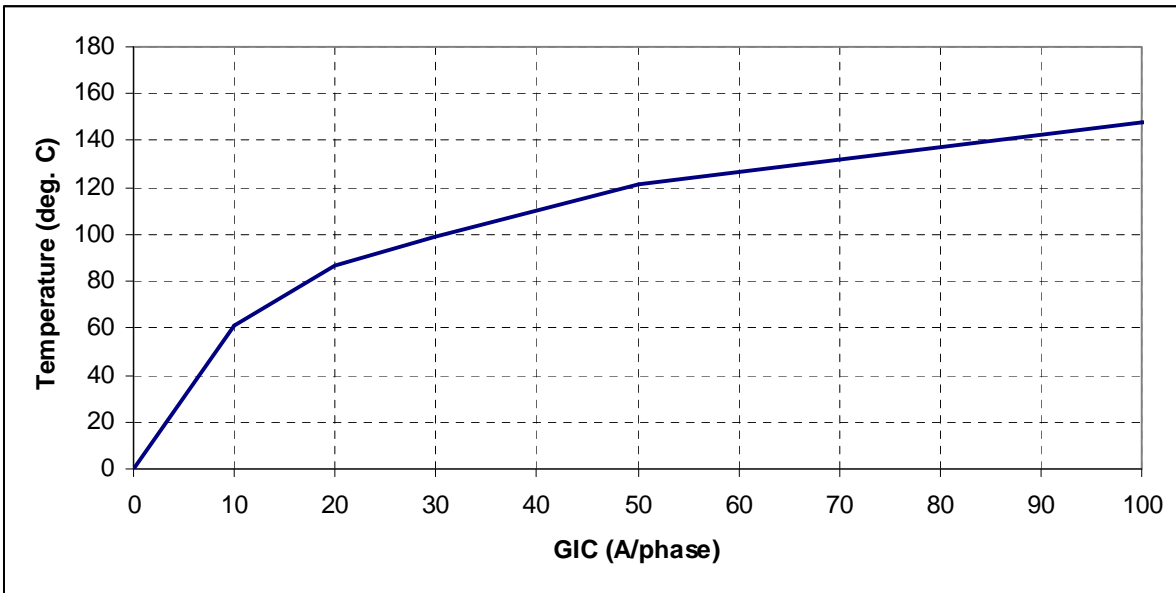


Figure I-5: Asymptotic thermal response of the tie plate of a 400 kV 400 MVA single-phase core-type autotransformer

The envelope in Figure 1 can be used as a conservative thermal assessment for effective GIC values of associated with the benchmark waveform and reference earth model (see Table 1).

Effective GIC (A/phase)	Metallic hot spot Temperature (°C)	Effective GIC (A/phase)	Metallic hot spot Temperature (°C)
0	80	100	182
10	107	110	186
20	128	120	190
30	139	130	193
40	148	140	204
50	157	150	213
60	169	160	221
70	170	170	230
75	172	180	234
80	175	190	241
90	179	200	247

For instance, if effective GIC is 130 A per phase and oil temperature is assumed to be 80°C, peak hot spot temperature is 193°C. This value is below the 200°C IEEE Std C57.91-2011 threshold for short time emergency loading and this transformer will have passed the thermal assessment. If the full heat run oil temperature is 67°C at maximum ambient temperature, then 150 A per phase of effective GIC translates into a peak hot spot temperature of 200°C and the transformer will have passed. If the limit is lowered to 180°C to account for the condition of the transformer, then this would be an indication to “sharpen the pencil” and perform a detailed assessment. Some methods are described in Reference [1].

The temperature envelope in Figure 1 corresponds to the values of effective GIC that result in the highest temperature for the benchmark GMD event. Different values of effective GIC could result in lower temperatures using the same model. For instance, the difference in upper and lower bounds of peak temperatures for the SVC coupling transformer model for 150 A per phase is approximately 30°C. In this case, GIC(t) should be generated to calculate the peak temperatures for the actual configuration of the transformer within the system as described in Reference [1]. Alternatively, a more precise thermal assessment could be carried out with a thermal model that more closely represents the thermal behavior of the transformer under consideration.

Similar to the discussion above, the envelope in Figure 3 can be used as a conservative thermal assessment for effective GIC values of associated with the supplemental waveform (see Table 2). The supplemental waveform has a sharper peak; therefore, the peak metallic hot spot temperatures associated with the supplemental waveform for the same peak current are slightly lower than those associated with the



benchmark waveform. In other words, for the same peak current value, the duration is relatively shorter with the supplemental waveform, and shorter duration means lower temperature. However, higher peak currents will occur with the supplemental benchmark, therefore, higher peak hot spot temperatures will occur. Comparing Tables 1 and 2 shows the magnitude of this difference.

<b>Effective GIC (A/phase)</b>	<b>Metallic hot spot Temperature (°C)</b>	<b>Effective GIC(A/phase)</b>	<b>Metallic hot spot Temperature (°C)</b>
0	80	120	188
10	107	130	191
20	124	140	194
30	137	150	198
40	147	160	203
50	156	170	209
60	161	180	214
70	162	190	229
75	165	200	237
80	169	220	248
85	172	230	253
90	177	250	276
100	181	275	298
110	185	300	316

## References

- [1] Transformer Thermal Impact Assessment white paper. Developed by the Project 2013-03 (Geomagnetic Disturbance) standard drafting team. October 2017. Available at: <http://www.nerc.com/pa/stand/Pages/TPL0071RI.aspx>
- [2] Marti, L; Rezaei-Zare, A.; and Narang, A. "Simulation of Transformer Hotspot Heating due to Geomagnetically Induced Currents." *IEEE Transactions on Power Delivery*, vol.28, no.1, pp.320-327, Jan. 2013.
- [3] Lahtinen, M. and Elovaara, J. "GIC occurrences and GIC test for 400 kV system transformer". *IEEE Transactions on Power Delivery*, Vol. 17, No. 2. April 2002.
- [4] Raith, J. and Ausserhofer, S. "GIC Strength verification of Power Transformers in a High Voltage Laboratory", GIC Workshop, Cape Town, April 2014
- [5] "IEEE Guide for Loading Mineral-Oil-Immersed Transformers and Step-Voltage Regulators." IEEE Std C57.91-2011 (Revision of IEEE Std C57.91-1995).
- [6] "IEEE Guide for Establishing Power Transformer Capability while under Geomagnetic Disturbances." IEEE Std C57.163-2015.

**Exhibit I**

**Supplemental GMD Event Description White Paper**

**NERC**

NORTH AMERICAN ELECTRIC  
RELIABILITY CORPORATION

# Supplemental Geomagnetic Disturbance Event Description

Project 2013-03 GMD Mitigation

October 2017

**RELIABILITY | ACCOUNTABILITY**



3353 Peachtree Road NE  
Suite 600, North Tower  
Atlanta, GA 30326  
404-446-2560 | [www.nerc.com](http://www.nerc.com)

# Table of Contents

---

Preface..... iii

Introduction..... iv

    Background ..... iv

    General Characteristics..... iv

Supplemental GMD Event Description ..... 1

    Supplemental GMD Event Geoelectric Field Amplitude..... 1

    Supplemental Geomagnetic Field Waveform..... 1

Appendix I – Technical Considerations..... 3

    Statistical Considerations..... 3

        Extreme Value Analysis ..... 3

    Spatial Considerations ..... 7

    Local Enhancement Waveform..... 13

    Transformer Thermal Assessment..... 15

Appendix II – Scaling the Supplemental GMD Event..... 16

    Scaling the Geomagnetic Field..... 16

    Scaling the Geoelectric Field..... 17

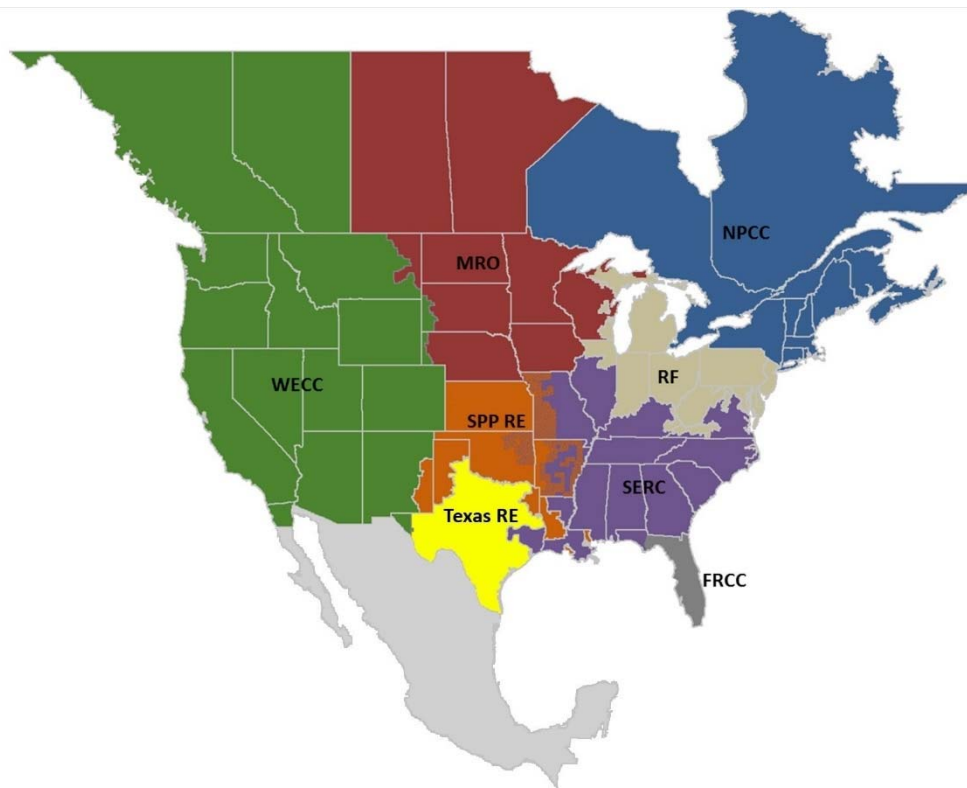
References ..... 21

## Preface

---

The North American Electric Reliability Corporation (NERC) is a not-for-profit international regulatory authority whose mission is to assure the reliability and security of the bulk power system (BPS) in North America. NERC develops and enforces Reliability Standards; annually assesses seasonal and long-term reliability; monitors the BPS through system awareness; and educates, trains, and certifies industry personnel. NERC’s area of responsibility spans the continental United States, Canada, and the northern portion of Baja California, Mexico. NERC is the Electric Reliability Organization (ERO) for North America, subject to oversight by the Federal Energy Regulatory Commission (FERC) and governmental authorities in Canada. NERC’s jurisdiction includes users, owners, and operators of the BPS, which serves more than 334 million people.

The North American BPS is divided into eight Regional Entity (RE) boundaries as shown in the map and corresponding table below.



*The North American BPS is divided into eight RE boundaries. The highlighted areas denote overlap as some load-serving entities participate in one Region while associated transmission owners/operators participate in another.*

<b>FRCC</b>	Florida Reliability Coordinating Council
<b>MRO</b>	Midwest Reliability Organization
<b>NPCC</b>	Northeast Power Coordinating Council
<b>RF</b>	ReliabilityFirst
<b>SERC</b>	SERC Reliability Corporation
<b>SPP RE</b>	Southwest Power Pool Regional Entity
<b>Texas RE</b>	Texas Reliability Entity
<b>WECC</b>	Western Electricity Coordinating Council

# Introduction

---

## Background

Proposed TPL-007-2 includes requirements for entities to perform two types of geomagnetic disturbance (GMD) Vulnerability Assessments to evaluate the potential impacts of GMD events on the Bulk Electric System (BES):

- The benchmark GMD Vulnerability Assessment is based on the benchmark GMD event associated with TPL-007-1, which was approved by the FERC Order No. 830 in September 2016. The benchmark GMD event is derived from spatially-averaged geoelectric field values to address potential wide-area effects that could be caused by a severe 1-in-100 year GMD event.<sup>1</sup>
- The supplemental GMD Vulnerability Assessment, based on the supplemental GMD event described in this white paper, is used by entities to evaluate localized enhancements of geomagnetic field during a severe GMD event that "could potentially affect the reliable operation of the Bulk-Power System."<sup>2</sup> Localized enhancements of geomagnetic field can result in geoelectric field values above the spatially-averaged benchmark in a local area.

The purpose of the supplemental GMD event description is to provide a defined event for assessing system performance for a GMD event which includes a local enhancement of the geomagnetic field. In addition to varying with time, geomagnetic fields can be spatially non-uniform with higher and lower strengths across a region. This spatial non-uniformity has been observed in a number of GMD events, so localized enhancement of field strength above the average value is considered. The supplemental GMD event defines the geomagnetic and geoelectric field values used to compute geomagnetically-induced current (GIC) flows for a supplemental GMD Vulnerability Assessment.

## General Characteristics

The supplemental GMD event described herein takes into consideration observed characteristics of a local geomagnetic field enhancement, recognizing that the science and understanding of these events is evolving. Based on observations and initial assessments, the characteristics of local enhancements include:

- Geographic area – The extent of local enhancements is on the order of 100km in North-South (latitude) direction but longer in East-West (longitude) direction. Further description of the geographic area is provided later in the white paper.
- Amplitude – The amplitude of the resulting geoelectric field is significantly higher than the geoelectric field that is calculated in the spatially-averaged Benchmark GMD event.
- Duration – The local enhancement in the geomagnetic field occurs over a time period of two to five minutes.
- Geoelectric field waveform – The supplemental GMD event waveform is the benchmark GMD event waveform with the addition of a local enhancement. The added local enhancement has amplitude and duration characteristics described above. The geoelectric field waveform has a strong influence on the hot spot heating of transformer windings and structural parts since thermal time constants of the transformer and time to peak of storm maxima are both on the order of minutes. The frequency content of the rate of change of the magnetic field (dB/dt) is a function of the waveform, which in turn has a direct effect on the geoelectric field since the earth response to dB/dt is frequency-dependent. As with the

---

<sup>1</sup> See *Benchmark Geomagnetic Disturbance Event Description* white paper, May 12, 2016. Filed by NERC in RM 15-11 on June 28, 2016.

<sup>2</sup> See FERC Order No. 830, P. 47. In Order 830, FERC directed NERC to develop modifications to the benchmark GMD event, included in TPL-007-1, such that assessments would not be based solely on spatially averaged data.

benchmark GMD event, the supplemental GMD event waveform is based on magnetic field data recorded by the Natural Resources Canada (NRCan) Ottawa (OTT) geomagnetic observatory during the March 13-14, 1989 event. This GMD event data was selected because analysis of recorded events indicates that the OTT observatory data for this period provides conservative results when performing thermal assessments of power transformers.<sup>3</sup>

---

<sup>3</sup> See *Benchmark Geomagnetic Disturbance Event Description* white paper, page 5 and Appendix I.



## Supplemental GMD Event Description

---

Severe GMD events are high-impact, low-frequency (HILF) events [1]; thus, GMD events used in system planning should consider the probability that the event will occur, as well as the impact or consequences of such an event. The supplemental GMD event is composed of the following elements: 1) a reference peak geoelectric field amplitude (V/km) derived from statistical analysis of historical magnetometer data; 2) scaling factors to account for local geomagnetic latitude; 3) scaling factors to account for local earth conductivity; and 4) a reference geomagnetic field time series or waveform to facilitate time-domain analysis of GMD impact on equipment.

### Supplemental GMD Event Geoelectric Field Amplitude

The supplemental GMD event field amplitude was determined through statistical analysis using the plane wave method [2]-[9] of geomagnetic field measurements from geomagnetic observatories in northern Europe [10] and the North American (i.e., Québec) reference earth model shown in Table 1 [11], supplemented by data from Greenland, Denmark and United States (i.e., Alaska). For details of the statistical considerations, see Appendix I. The Québec earth model is generally resistive and the geological structure is relatively well understood.

Thickness (km)	Resistivity ( $\Omega\text{-m}$ )
15	20,000
10	200
125	1,000
200	100
$\infty$	3

The statistical analysis (see Appendix I) resulted in conservative peak geoelectric field amplitude of approximately 12 V/km. For steady-state GIC and load flow analysis, the direction of the geoelectric field is assumed to be variable meaning that it can be in any direction (Eastward, Northward, or a vectorial combination thereof).

The regional geoelectric field peak amplitude,  $E_{peak}$ , to be used in calculating GIC in the GIC system model can be obtained from the reference value of 12 V/km using the following relationship

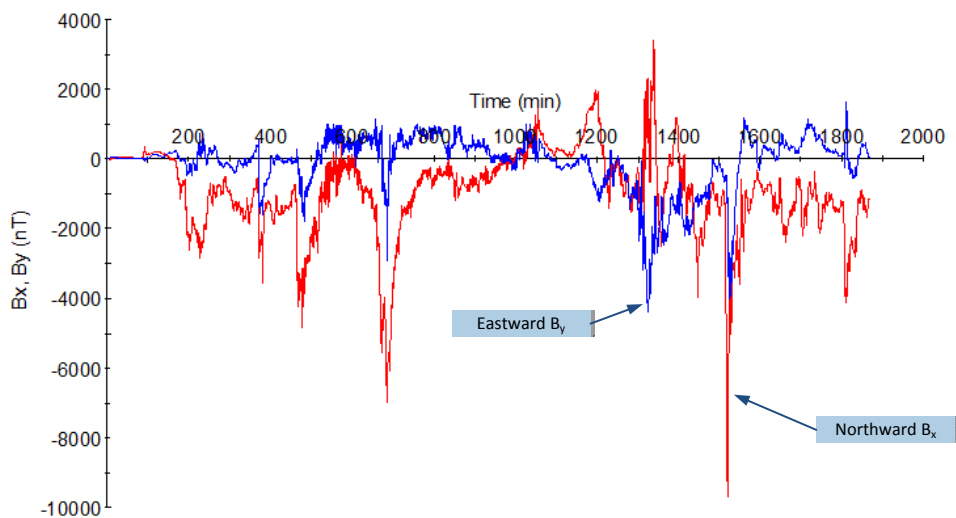
$$E_{peak} = 12 \times \alpha \times \beta_s \text{ (V/km)} \quad (1)$$

where  $\alpha$  is the scaling factor to account for local geomagnetic latitude, and  $\beta_s$  is a scaling factor for the supplemental GMD event to account for the local earth conductivity structure (see Appendix II).

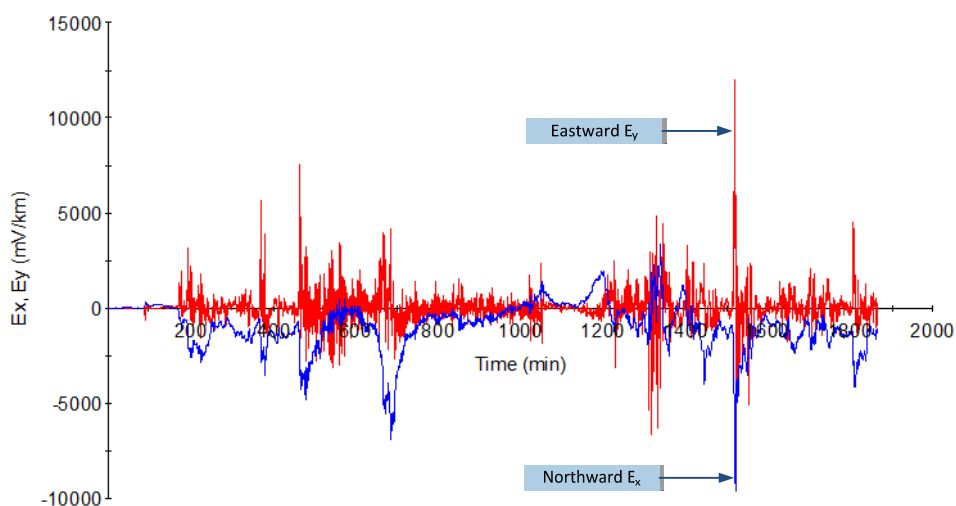
### Supplemental Geomagnetic Field Waveform

The supplemental geomagnetic field waveform is the benchmark geomagnetic field waveform with the addition of a local enhancement. Both the benchmark and supplemental geomagnetic field waveforms are used to calculate the GIC time series,  $GIC(t)$ , required for transformer thermal impact assessments. The supplemental waveform includes a local enhancement, inserted at UT 1:18 March 14, 1989 in Figure 1 below. This time corresponds to the largest calculated geoelectric fields during the benchmark GMD event. The amplitude of the local enhancement is based on a statistical analysis of a number of GMD events, discussed in Appendix I. The duration of the enhancement is based on the characteristics of observed localized enhancements as discussed in Appendix I.

The geomagnetic latitude of the Ottawa geomagnetic observatory is 55°; therefore, the amplitude of the geomagnetic field measurement data with a local enhancement was scaled up to the 60° reference geomagnetic latitude (see Figure 1) such that the resulting peak geoelectric field amplitude computed using the reference earth model was 12 V/km (see Figure 2). Sampling rate for the geomagnetic field waveform is 10 seconds.



**Figure 1: Supplemental Geomagnetic Field Waveform**  
 Red  $B_x$  (Northward), Blue  $B_y$  (Eastward), Referenced to pre-event quiet conditions



**Figure 2: Supplemental Geoelectric Field Waveform**  
 Red  $E_y$  (Eastward) and Blue  $E_x$  (Northward)

## Appendix I – Technical Considerations

---

The following sections describe the technical justification of the assumptions that were made in the development of the supplemental GMD event.

### Statistical Considerations

The peak geoelectric field amplitude of the supplemental GMD event was determined through statistical analysis of modern 10-second geomagnetic field data and corresponding calculated geoelectric field amplitudes. The objective of the analysis was to estimate the geoelectric field amplitude that is associated with a 1 in 100 year frequency of occurrence. The same data set and similar statistical techniques were used in determining the peak geoelectric field amplitude of the benchmark GMD event, including extreme value analysis discussed in the following section.<sup>4</sup> The fundamental difference in the supplemental GMD event amplitude is that it is based on observations taken at each individual station (i.e., localized measurements), in contrast with the spatially averaged geoelectric fields used in the *Benchmark Geomagnetic Disturbance Event Description* white paper.<sup>5</sup>

### Extreme Value Analysis

The objective of extreme value analysis is to describe the behavior of a stochastic process at extreme deviations from the median. In general, the intent is to quantify the probability of an event more extreme than any previously observed. In particular, we are concerned with estimating the 95% confidence interval of the maximum geoelectric field amplitude to be expected within a 100-year return period.<sup>6</sup>

The data set consists of 23 years of daily maximum geoelectric field amplitudes derived from individual stations<sup>7</sup> in the IMAGE magnetometer chain, using the Québec earth model as a reference. Figure I-1 shows a scatter plot of geoelectric field amplitudes that exceed 2 V/km across the IMAGE stations. The plot indicates that there is seasonality in extreme observations associated with the 11-year solar cycle.

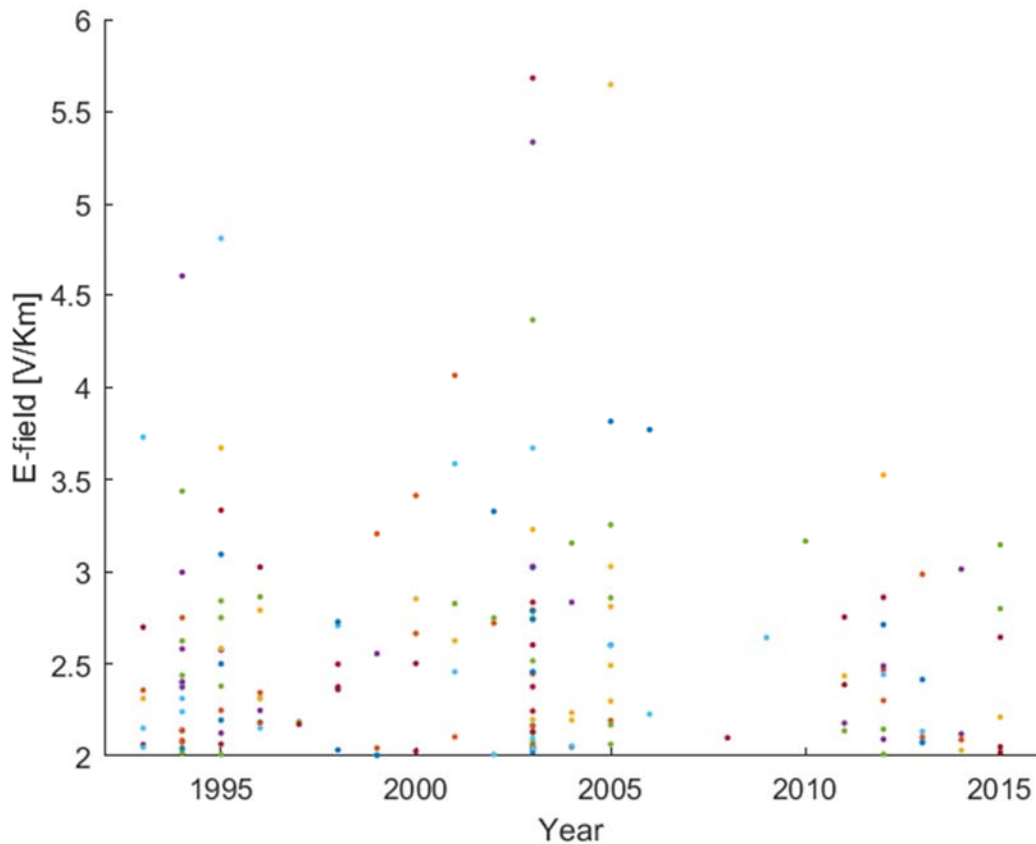
---

<sup>4</sup> See *Benchmark Geomagnetic Disturbance Event Description* white paper, Appendix I, pages 8-13.

<sup>5</sup> Averaging the geoelectric field values of stations in geographic groups is referred to as spatial averaging in the *Benchmark Geomagnetic Disturbance Event Description*. Spatial averaging was used to characterize GMD events over a geographic area relevant to the interconnected transmission system for purposes of assessing area effects such as voltage collapse and widespread equipment risk. See *Benchmark Geomagnetic Disturbance Event Description* white paper, Appendix I, pages 9-10.

<sup>6</sup> A 95 percent confidence interval means that, if repeated samples were obtained, the return level would lie within the confidence interval for 95 percent of the samples.

<sup>7</sup> US – <https://geomag.usgs.gov/>; Canada – <http://geomag.nrcan.gc.ca/lab/default-en.php>.



**Figure I-1: Scatter Plot of Geoelectric Fields that Exceed a 2 V/km Threshold**  
Data source [11]: IMAGE magnetometer chain from 1993-2015.

Several statistical methods can be used to conduct extreme value analysis. The most commonly applied include: Generalized Extreme Value (GEV), Point Over Threshold (POT), R-Largest, and Point Process (PP). In general, all methods assume independent and identically distributed (iid) data [12].

Table I-1 shows a summary of the estimated parameters and return levels obtained from different statistical methods. The parameters were estimated using the Maximum Likelihood Estimator (MLE). Since the distribution parameters do not have an intuitive interpretation, the expected geoelectric field amplitude for a 100-year return period is also included in Table I-1. The 95% confidence interval of the 100-year return level was calculated using the delta method and the profile likelihood. The delta method relies on the Gaussian approximation to the distribution of the MLE; this approximation can be poor for long return periods. In general, the profile likelihood provides a better description of the return level.

Table I-1: Extreme Value Analysis					
Statistical Model	Estimated Parameters	Hypothesis Testing	100 Year Return Level		
			Mean [V/km]	95% CI Delta [V/km]	95% CI P-Likelihood [V/km]
(1) GEV	$\mu=2.976$ (0.193)  $\sigma=0.829$ (0.1357)  $\xi=-0.0655$ (0.1446)	$H_0: \xi=0$ $p = 0.66$	6.9	[4.3, 8.2]	[5.2, 11.4]
(2) GEV, reparametrization $\mu = \beta_0 + \beta_1 \times \sin\left(\frac{t}{T} + \phi\right)$	$\beta_0= 2.964$ (0.151)  $\beta_1=0.582$ (0.155)  $\sigma=0.627$ (0.114)  $\xi=0.09$ (0.183)	$H_0: \beta_1=0$ $p = 0.00$  $H_0: \xi=0$ $p = 0.6$	7.1	[4, 10.2]	[5.5, 18]
(3) POT, threshold=2 V/km 3 day decluster. 143 observations > 2V/km.	$\sigma=0.592$ (0.074)  $\xi=0.077$ (0.093)		6.9	[4.5, 9.4]	[5.4, 11.9]
(4) POT, threshold=2V/km reparametrization, $\sigma = \beta_0 + \beta_1 \times \sin\left(\frac{t}{T} + \phi\right)$	$\beta_0=0.58$ (0.073)  $\beta_1=0.107$ (0.082)  $\xi=0.037$ (0.097)	$H_0: B1=0$ $p = 0.2$	7	[4.6, 9.3]	[5.5, 11.7]

Statistical model (1) in Table I-1 is the traditional GEV estimation using blocks of one year maxima; i.e., only 23 data points are used in the estimation. The mean expected amplitude of the geoelectric field for a 100-year return level is approximately 7 V/km. Since GEV works with blocks of maxima, it is typically regarded as a wasteful approach.

As discussed previously, GEV assumes that the data is iid. Based on the scatter plot shown in Figure I-1, the iid statistical assumption is not warranted by the data. Statistical model (2) in Table I-1 is a reparametrization of the GEV distribution contemplating the 11-year seasonality in the mean,

$$\mu = \beta_0 + \beta_1 \times \sin\left(\frac{t}{T} + \phi\right)$$

where  $\beta_0$  represents the offset in the mean,  $\beta_1$  describes the 11-year seasonality,  $T$  is the period (11 years), and  $\phi$  is a constant phase shift.

A likelihood ratio test is used to test the hypothesis that  $\beta_1$  is zero. The null hypothesis,  $H_0: \beta_1=0$ , is rejected with a p-value of 0.0032; as expected, the 11-year seasonality has explanatory power. The blocks of maxima during the solar minimum are better represented in the reparametrized GEV. The mean return level is still 7 V/km, but the confidence interval is wider, [5.5, 18] V/km for the profile likelihood (calculated at solar maximum).

Statistical model (3) in Table I-1 is the traditional POT estimation using a threshold  $u$  of 2 V/km; the data was declustered using a 1-day run. The data set consists of normalized excesses over a threshold, and therefore, the sample size for POT is increased if more than one extreme observation per year is available (in the GEV approach, only the maximum observation over the year was taken; in the POT method, a single year can have multiple observations over the threshold). The selection of the threshold  $u$  is a compromise between bias and variance. The asymptotic basis of the model relies on a high threshold; too low a threshold will likely lead to bias. On the other hand, too high a threshold will reduce the sample size and result in high variance. A threshold of 2V/km was determined to be a good choice, giving rise to 143 observations above the threshold.

The mean return level for statistical model (3),  $\sim 7$  V/km, is consistent with the GEV estimates. However, due to the larger sample size the POT method is more efficient rendering a confidence interval of [5.4, 11.9] V/km for the profile likelihood method.

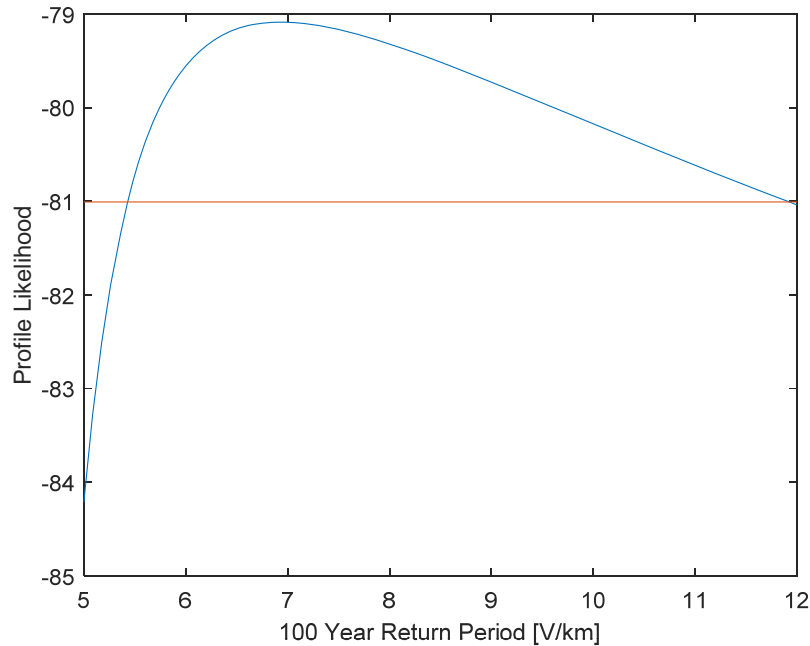
In an attempt to cope with potential heteroskedasticity in the data, a reparametrization of POT is proposed in statistical model (4) in Table I-1,

$$\sigma = \alpha_0 + \alpha_1 \times \sin\left(\frac{t}{T} + \phi\right)$$

where  $\alpha_0$  represents the offset in the standard deviation,  $\alpha_1$  describes the 11-year seasonality,  $T$  is the period ( $365.25 \cdot 11$ ), and  $\phi$  is a constant phase shift.

The parameter  $\alpha_1$  is not statistically significant; the null hypothesis,  $H_0: \alpha_1=0$ , is not rejected with a p-value of 0.2. The proposed reparametrization does not have explanatory power, and consequently, the mean return level 7 V/km and confidence intervals remain virtually unchanged [5.5, 11.7]. As a final remark, it is emphasized that the confidence interval obtained using the profile likelihood is preferred over the delta method.

Figure I-2 shows the profile likelihood of the 100-year return level of statistical model (3). Note that the profile likelihood is highly asymmetric with a positive skew, rendering a larger upper limit for the confidence interval. Recall that the delta method assumes a normal distribution for the MLEs, and therefore, the confidence interval is symmetric around the mean.



**Figure I-2: Profile Likelihood for 100-year Return Level for Statistical Model (3)**

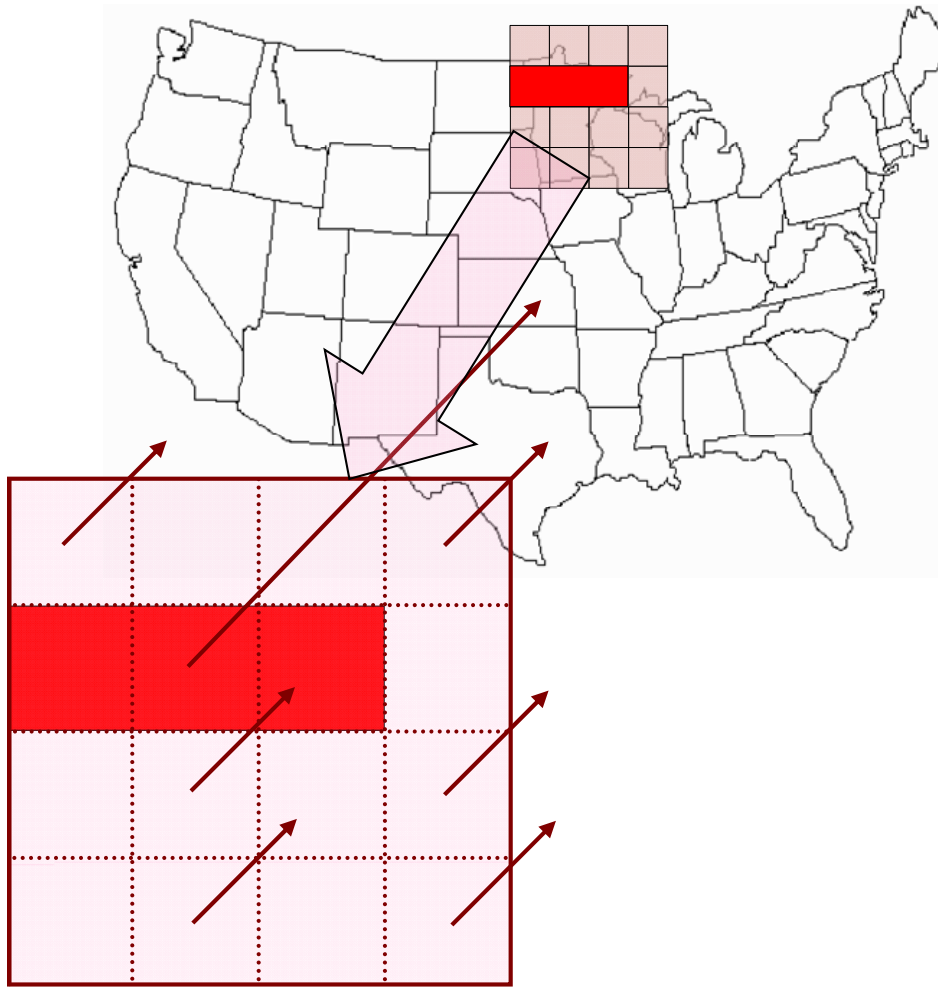
To conclude, the traditional GEV (1) is misspecified; the statistical assumptions (i.e., iid) are not warranted by the data. The model was reparametrized to cope with seasonality in the data. Statistical models (3) and (4) better utilize the available extreme measurements and they are therefore preferred over statistical model (2). A geoelectric field amplitude of 12 V/km is selected for the supplemental GMD event to represent the upper limit of the 95 percent confidence interval for a 100-year return interval.

## Spatial Considerations

The spatial structure of high-latitude geomagnetic fields can be very complex during strong geomagnetic storm events [13]-[14]. One reflection of this spatial complexity is localized geomagnetic field enhancements (local enhancements) that result in high amplitude geoelectric fields in regions of a few hundred kilometers. Figure I-3 illustrates this spatial complexity of the storm-time geoelectric fields.<sup>8</sup> In areas indicated by the bright red location, the geoelectric field can be substantially larger than at neighboring locations. These enhancements are primarily the result of external (geomagnetic field) conditions, and not local geological factors such as coastal effects.<sup>9</sup>

<sup>8</sup> Figure I-3 is for illustration purposes only, and is not meant to suggest that a particular area is more likely to experience a localized enhanced geoelectric field. The depiction is not to scale.

<sup>9</sup> Localized externally-driven geomagnetic phenomena should not be confused with localized geoelectric field enhancements due to complex electromagnetic response of the ground to external excitation. Complex 3D geological conditions such as those at coastal regions can lead to localized geoelectric field enhancements but those are not considered here.



**Figure I-3: Illustration of the Spatial Scale between Localized Enhancements and Larger Spatial Scale Amplitudes of Goelectric Field during a Strong Geomagnetic Storm**  
 In this figure, the red rectangle illustrates a spatially localized field enhancement.

The supplemental GMD event is designed to address local effects caused by a severe GMD event, such as increased var absorption and voltage depressions.

A number of GMD events were analyzed to identify the basic characteristics of local enhancements. Three (3) solar storms studied and described below are:

- March 13, 1989
- October 29-30, 2003
- March 17, 2015

Four localized events within those storms were identified and analyzed. Geomagnetic field recordings were collected for these storms and the goelectric field was computed using the 1D plane wave method and the reference Québec ground model. In each case, a local enhancement was correlated, generally oriented parallel to the westward ionospheric electrojet associated with ongoing larger scale geomagnetic activity. (See Figures I-4 – I-7 below).



Goelectric field distribution 0089-03-13T21:44:00 UT. Max. IEI: 5.90 V/km.

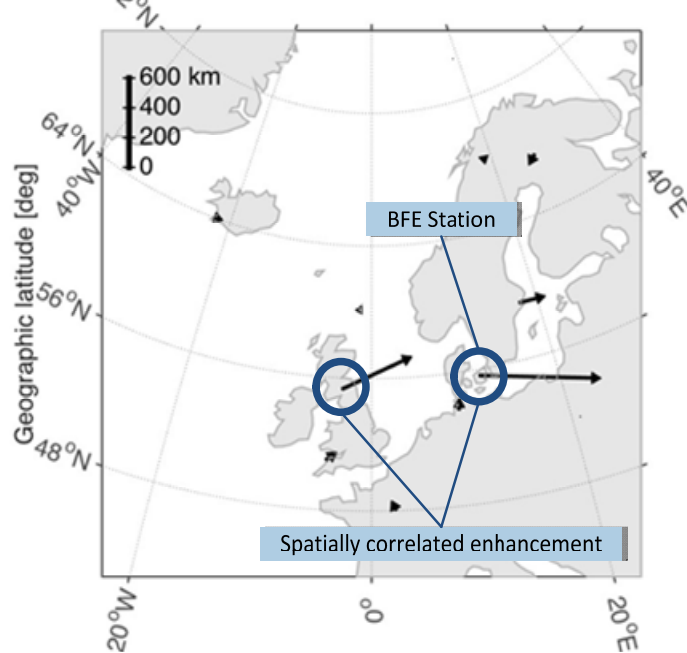


Figure I-4: March 13, 1989, at 21:44 UT, Brorfelde (BFE), Denmark

Goelectric field distribution 2003-10-29T06:47:20 UT. Max. IEI: 9.31 V/km.

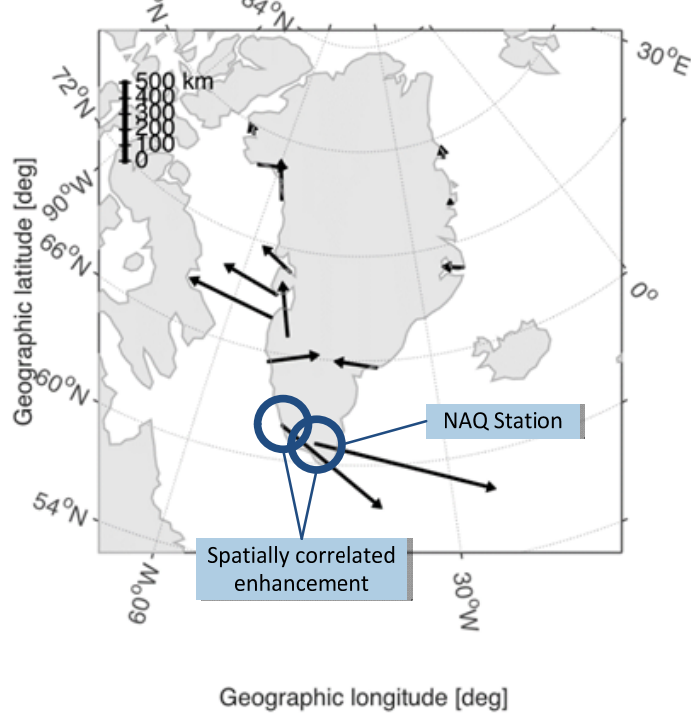


Figure I-5: October 29, 2003, at 06:47 UT, Narsarsuaq (NAQ), Greenland

Goelectric field distribution 2003-10-30T16:49:30 UT. Max. IEI: 5.68 V/km.

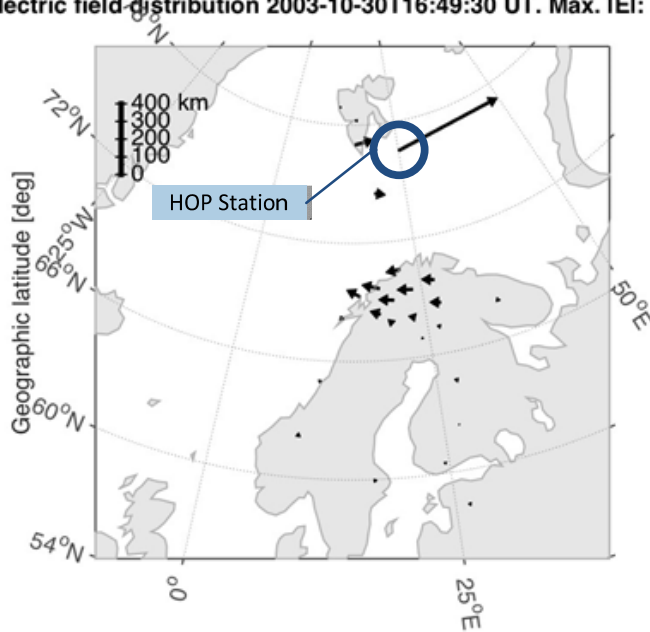


Figure I-6: October 30, 2003, at 16:49UT, Hopen Island (HOP), Svalbard, Norway

Goelectric field distribution 2015-03-17T13:33:00 UT. Max. IEI: 3.46 V/km.

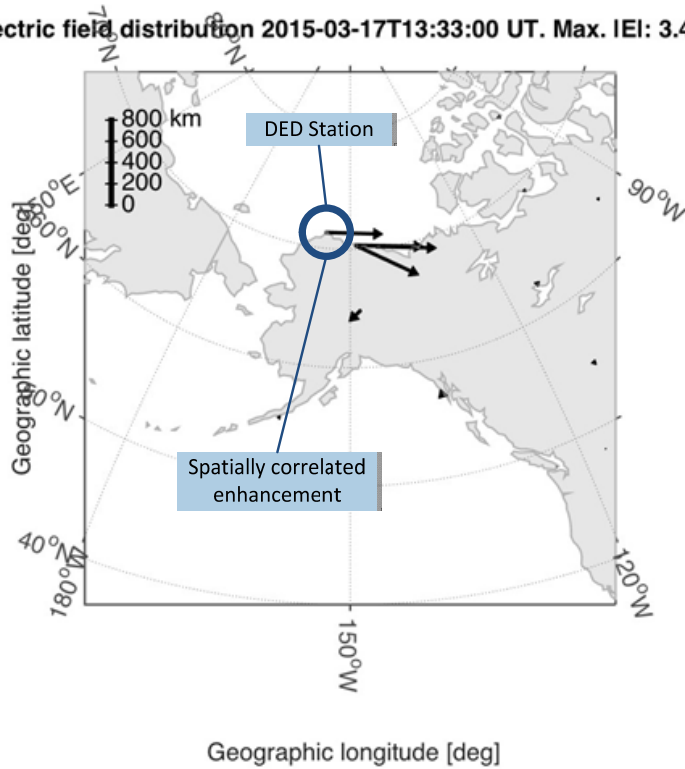


Figure I-7: March 17, 2015, at 13:33 UT, Deadhorse, Alaska, USA

All of the above events were analyzed by reviewing the time series magnetic field data and transforming it to an electric field and focusing on the time period of the spatially correlated local enhancement. There were apparent similarities in the character of the local enhancements. The local enhancements occurred during peak periods of geomagnetic activity and were distinguished by relatively brief excursions of rapid magnetic field variation. With respect to time duration, the local enhancements generally occurred over a period of 2-5 minutes. (See Figures I-8 – I-11)

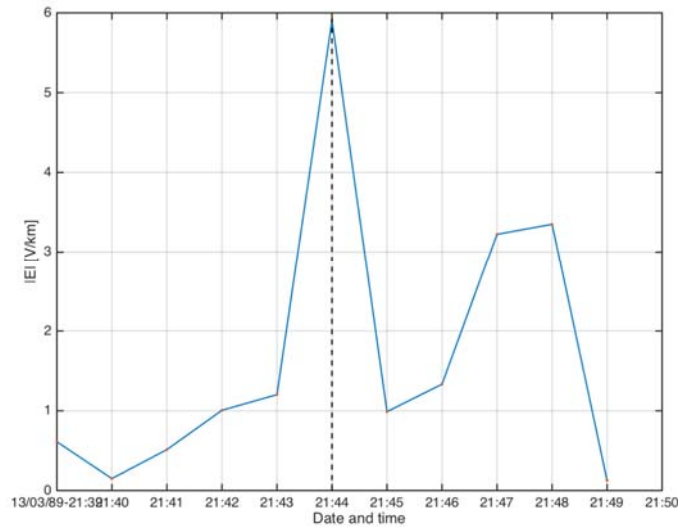


Figure I-8: Geoelectric field March 13, 1989, at 21:44 UT, Brorfelde (BFE), Denmark

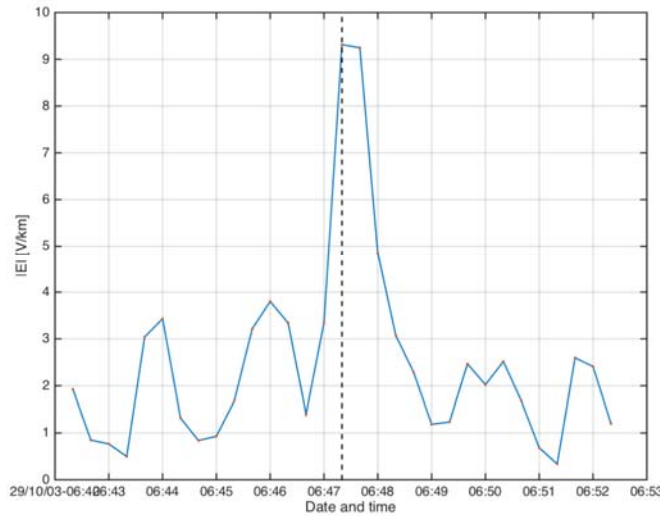
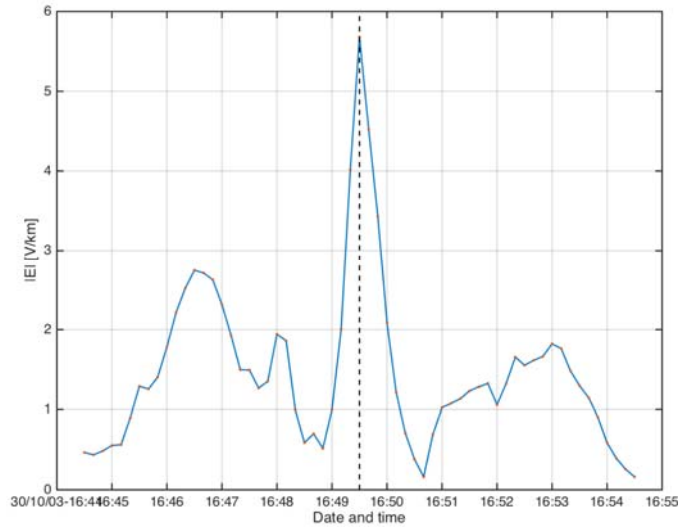
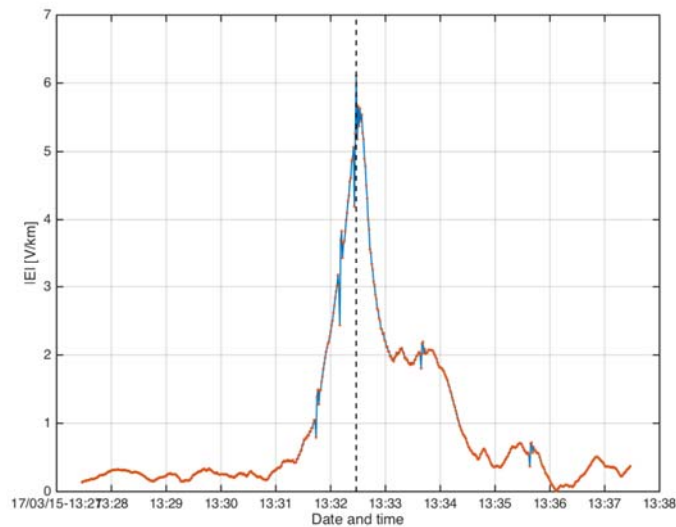


Figure I-9: Geoelectric field October 29, 2003, at 06:47 UT, Narsarsuaq (NAQ), Greenland



**Figure I-10: Geoelectric field October 30, 2003, at 16:49 UT, Hopen Island (HOP), Norway**



**Figure I-11 – Geoelectric field March 17, 2015, at 13:33 UT, Deadhorse, Alaska, USA**

Based on the above analysis and the previous work associated with the benchmark GMD event, it is reasonable to incorporate a second (or supplemental) assessment into TPL-007-2 to account for the potential impact of a local enhancement in both the network analysis and the transformer thermal assessment(s).

With respect to geographic area of the localized enhancement, the historical geomagnetic field data analyzed so far provides some insight. Analysis suggests that the enhancements will occur in a relatively narrow band of geomagnetic latitude (on the order of 100 km) and wider longitudinal width (on the order of 500 km) as a consequence of the westward-oriented structure of the source in the ionosphere.

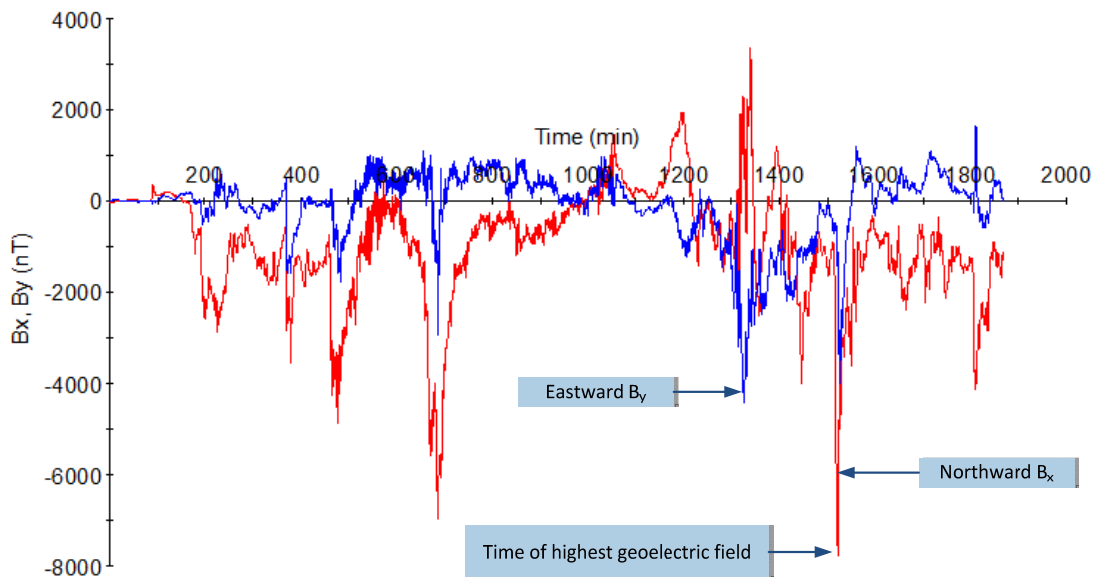
Proposed TPL-007-2 provides flexibility for planners to determine how to apply the supplemental GMD event to the planning area. Acceptable approaches include, but are not limited to:

- Applying the peak geoelectric field for the supplemental GMD event (12 V/km scaled to the planning area) over the entire planning area;
- Applying a spatially limited (e.g., 100 km in North-South direction and 500 km in East-West direction) geoelectric field enhancement (12 V/km scaled to the planning area) over a portion(s) of the system, and applying the benchmark GMD event over the rest of the system.
- Other methods to adjust the benchmark GMD event analysis for localized geoelectric field enhancement.

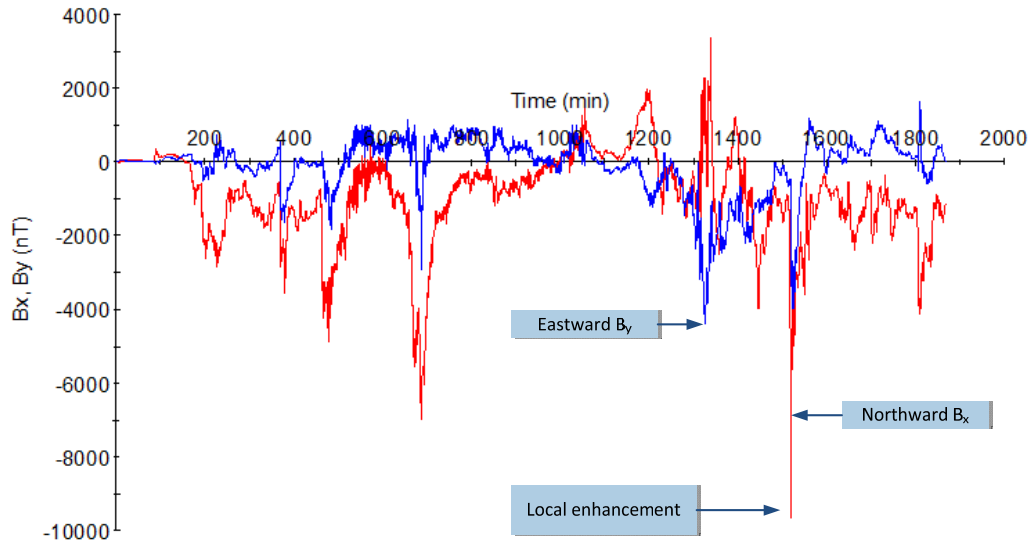
Given the current state of knowledge regarding the spatial extent of a local geomagnetic field enhancements, upper geographic boundaries, such as the values used in the approaches above, are reasonable but are not definitive.

## Local Enhancement Waveform

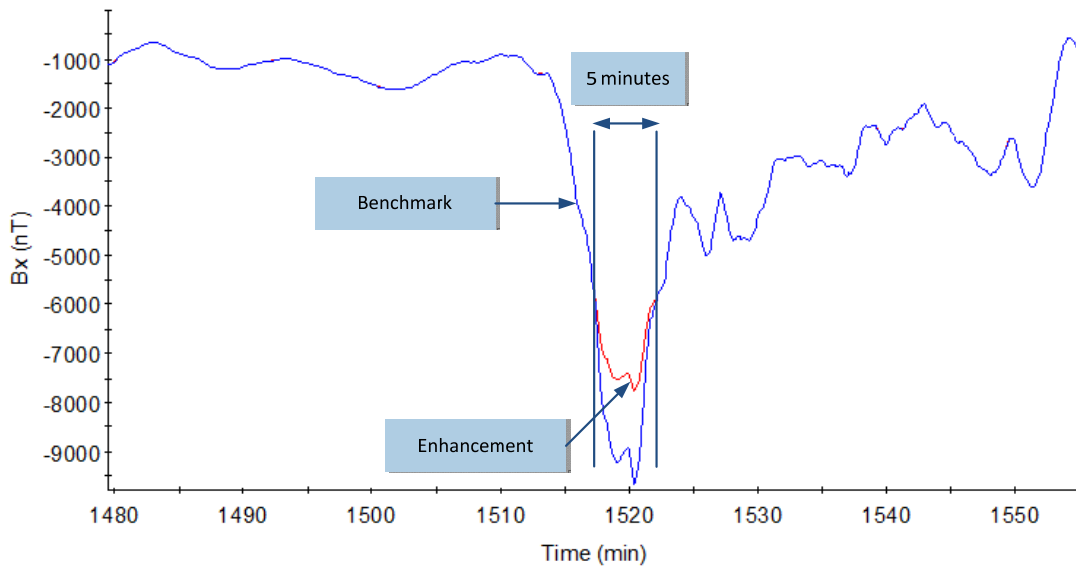
The supplemental geomagnetic field waveform was derived by modifying the benchmark GMD event waveform to emulate the observed events described above. The temporal location of the enhancement corresponds to the time of the benchmark event with the highest geoelectric field. The local enhancement was constructed by scaling linearly a 5-minute portion of the benchmark geomagnetic field so that the peak geoelectric field is 12 V/km at a geomagnetic latitude of 60° and reference earth model. Figure I-12 shows the benchmark geomagnetic field and Figure I-13 shows the supplemental event geomagnetic field. Figure I-14 expands the view into  $B_x$ , with and without the local enhancement. Figure I-15 is the corresponding expanded view of the geoelectric field magnitude with and without the local enhancement.



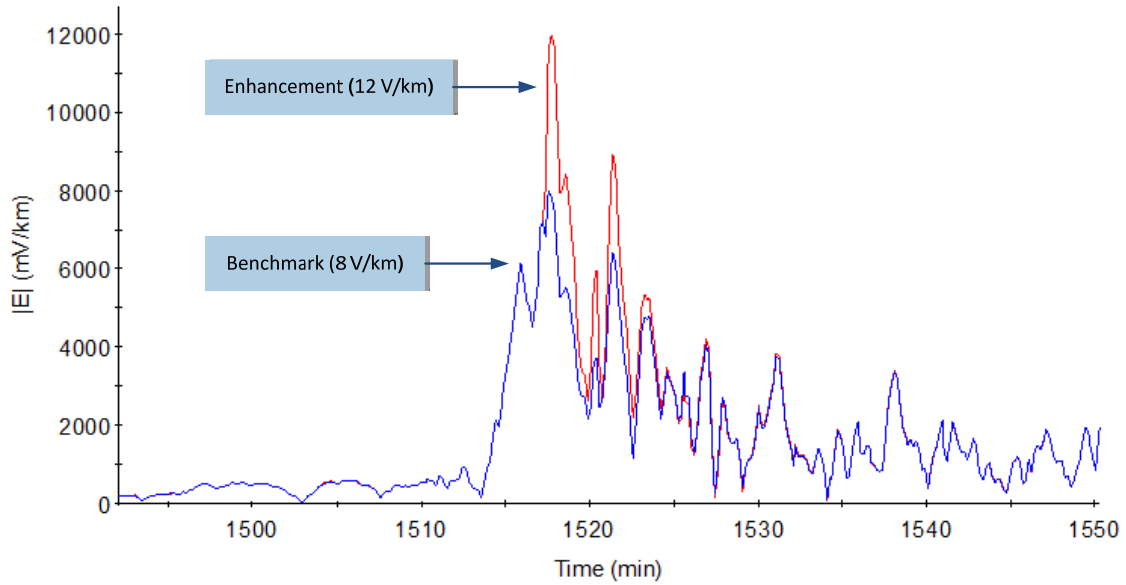
**Figure I-12: Benchmark Geomagnetic Field**  
Red  $B_x$  (Northward), Blue  $B_y$  (Eastward)



**Figure I-13: Supplemental Geomagnetic Field Waveform  
Red  $B_x$  (Northward), Blue  $B_y$  (Eastward)**



**Figure I-14: Red Benchmark  $B_x$  and Blue Supplemental  $B_x$  (Northward) – Expanded View**



**Figure I-15: Magnitude of the Geoelectric Field  
Benchmark Blue and Supplemental Red – Expanded View**

## Transformer Thermal Assessment

The local enhancement of the supplemental GMD event waveform can have a material impact on the temperature rise (hot-spot heating or metallic parts) even though the duration of the local enhancement is approximately five minutes. Thermal assessments based on the supplemental GMD event can be performed using the same methods employed for benchmark thermal assessments.<sup>10</sup>

<sup>10</sup> See Transformer Thermal Impact Assessment white paper: <http://www.nerc.com/pa/Stand/Pages/Project-2013-03-Geomagnetic-Disturbance-Mitigation.aspx>.

## Appendix II – Scaling the Supplemental GMD Event

The intensity of a GMD event depends on geographical considerations such as geomagnetic latitude and local earth conductivity [2].<sup>11</sup> Scaling factors for geomagnetic latitude take into consideration that the intensity of a GMD event varies according to latitude-based geographical location. Scaling factors for earth conductivity take into account that the induced geoelectric field depends on earth conductivity, and that different parts of the continent have different earth conductivity and deep earth structure.

Scaling the supplemental GMD event differs from the benchmark GMD event in two ways:

- $E_{\text{peak}}$  is 12 V/km instead of 8 V/km
- Beta factors for scaling the geoelectric field based on earth conductivity are different (see Table II-2)

More discussion, including example calculations, is contained in the Benchmark GMD Event Description white paper.

### Scaling the Geomagnetic Field

The supplemental GMD event is defined for geomagnetic latitude of 60° and it must be scaled to account for regional differences based on geomagnetic latitude. To allow usage of the supplemental geomagnetic field waveform in other locations, Table II-1 summarizes the scaling factor  $\alpha$  correlating peak geoelectric field to geomagnetic latitude as illustrated in Figure II-1 [3]. This scaling factor  $\alpha$  has been obtained from a large number of global geomagnetic field observations of all major geomagnetic storms since the late 1980s [15]-[17], and can be approximated with the empirical expression in (II.1):

$$\alpha = 0.001 \times e^{(0.115 \times L)} \quad (\text{II.1})$$

where L is the geomagnetic latitude in degrees and  $0.1 \leq \alpha \leq 1.0$ .

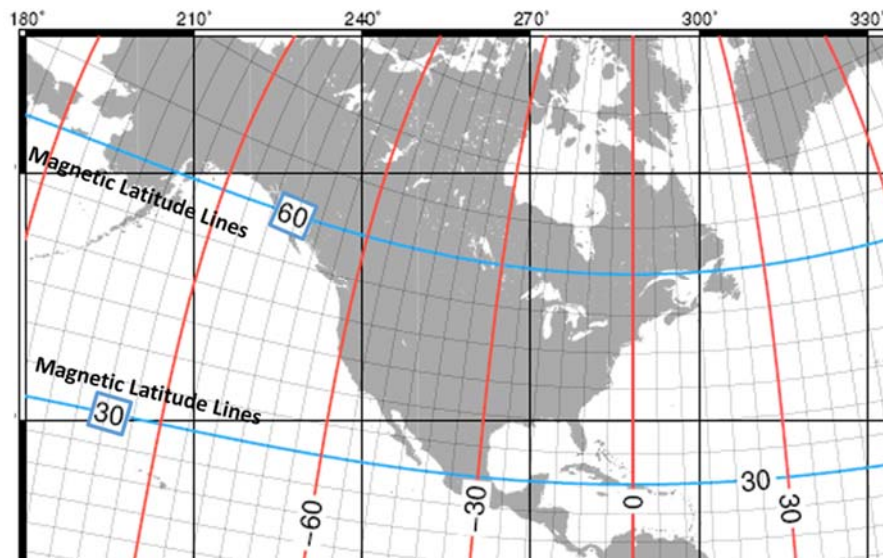


Figure II-1: Geomagnetic Latitude Lines in North America

<sup>11</sup> Geomagnetic latitude is analogous to geographic latitude, except that bearing is in relation to the magnetic poles, as opposed to the geographic poles. Geomagnetic phenomena are often best organized as a function of geomagnetic coordinates. Local earth conductivity refers to the electrical characteristics to depths of hundreds of km down to the earth's mantle. In general terms, lower ground conductivity results in higher geoelectric field amplitudes.



Table II-1: Geomagnetic Field Scaling Factors	
Geomagnetic Latitude (Degrees)	Scaling Factor1 ( $\alpha$ )
$\leq 40$	0.10
45	0.2
50	0.3
54	0.5
56	0.6
57	0.7
58	0.8
59	0.9
$\geq 60$	1.0

## Scaling the Goelectric Field

The supplemental GMD event is defined for the reference Québec earth model provided in Table 1. This earth model has been used in many peer-reviewed technical articles [11, 15]. The peak goelectric field depends on the geomagnetic field waveform and the local earth conductivity. Ideally, the peak goelectric field,  $E_{peak}$ , is obtained by calculating the goelectric field from the scaled geomagnetic field waveform using the plane wave method and taking the maximum value of the resulting waveforms:

$$\begin{aligned}
 E_N &= (z(t)/\mu_0)^* \times B_E(t) \\
 E_N &= -(z(t)/\mu_0)^* \times B_N(t) \\
 E_{peak} &= \max\{|E_E(t), E_N(t)|\}
 \end{aligned}
 \tag{II.2}$$

where,

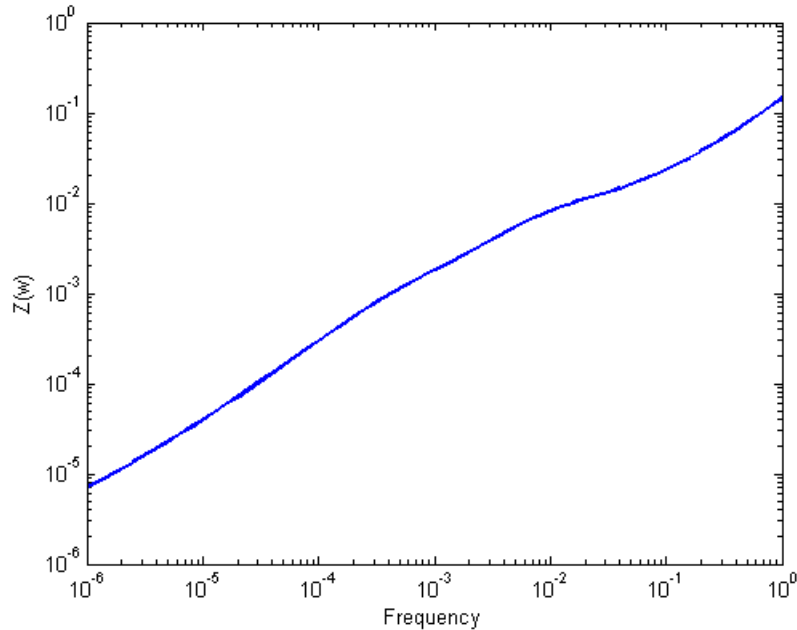
\*denotes convolution in the time domain,

$z(t)$  is the impulse response for the earth surface impedance calculated from the laterally uniform or 1D earth model,

$B_E(t)$ ,  $B_N(t)$  are the scaled Eastward and Northward geomagnetic field waveforms, and

$|E_E(t)$ ,  $E_N(t)|$  are the magnitudes of the calculated Eastward and Northward goelectric field  $E_E(t)$  and  $E_N(t)$ .

As noted previously, the response of the earth to  $B(t)$  (and  $dB/dt$ ) is frequency dependent. Figure II-2 shows the magnitude of  $Z(\omega)$  for the reference earth model.



**Figure II-2: Magnitude of the Earth Surface Impedance for the Reference Earth Model**

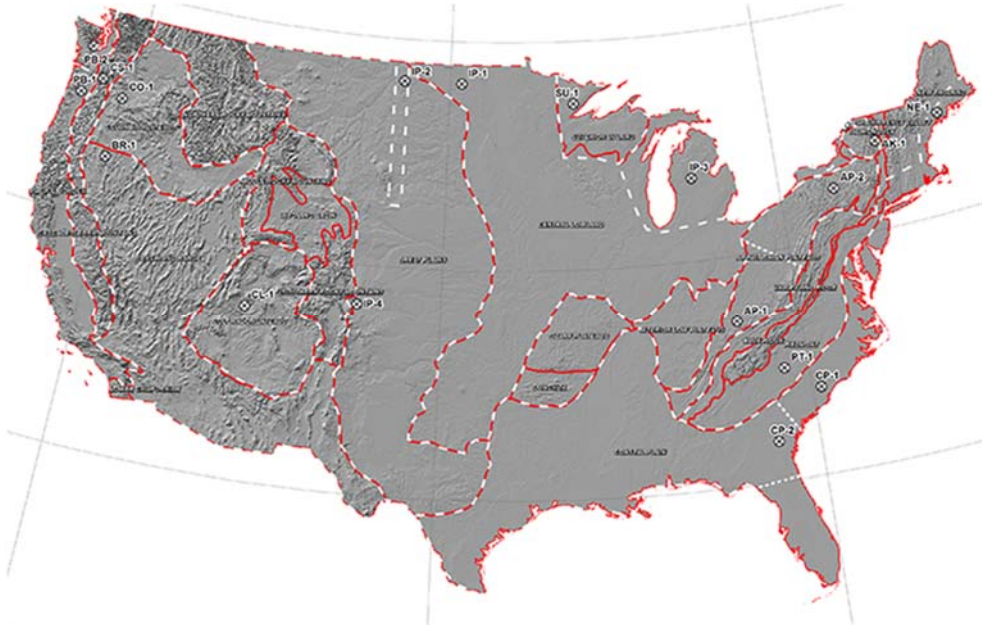
If a utility does not have the capability of calculating the waveform or time series for the geoelectric field, an earth conductivity scaling factor  $\beta_s$  can be obtained from Table II-2. Using  $\alpha$  and  $\beta$ , the peak geoelectric field  $E_{peak}$  for a specific service territory shown in Figure II-3 can be obtained using (II.3).

$$E_{peak} = 12 \times \alpha \times \beta_s (V/km) \quad (II.3)$$

It should be noted that (II.3) is an approximation based on the following assumptions:

- The earth models used to calculate Table II-2 for the United States are from published information available on the USGS website. These scaling factors are slightly lower than the ones in the benchmark because the supplemental benchmark waveform has a higher frequency content at the time of the local enhancement.
- The models used to calculate Table II-2 for Canada were obtained from NRCAN and reflect the average structure for large regions. When models are developed for sub-regions, there will be variance (to a greater or lesser degree) from the average model. For instance, detailed models for Ontario have been developed by NRCAN and consist of seven major sub-regions.
- The conductivity scaling factor  $\beta_s$  is calculated as the quotient of the local geoelectric field peak amplitude in a physiographic region with respect to the reference peak amplitude value of 12 V/km. Both geoelectric field peak amplitudes are calculated using the supplemental geomagnetic field time series. If a different geomagnetic field time series were used, the calculated scaling factors ( $\beta$ ) would be different than the values in Table II-2 because the frequency content of storm maxima is, in principle, different for every storm. If a utility has technically-sound earth models for its service territory and sub-regions thereof, then the use of such earth models is preferable to estimate  $E_{peak}$ .
- When a ground conductivity model is not available the planning entity should use the largest  $\beta_s$  factor of adjacent physiographic regions or a technically-justified value.

### Physiographic Regions of the Continental United States



### Physiographic Regions of Canada



Figure II-3: Physiographic Regions of North America

<b>Table II-2 Supplemental Geoelectric Field Scaling Factors</b>	
<b>Earth model</b>	<b>Scaling Factor (<math>\beta</math>)</b>
AK1A	0.51
AK1B	0.51
AP1	0.30
AP2	0.78
BR1	0.22
CL1	0.73
CO1	0.25
CP1	0.77
CP2	0.86
FL1	0.73
CS1	0.37
IP1	0.90
IP2	0.25
IP3	0.90
IP4	0.35
NE1	0.77
PB1	0.55
PB2	0.39
PT1	1.19
SL1	0.49
SU1	0.90
BOU	0.24
FBK	0.56
PRU	0.22
BC	0.62
PRAIRIES	0.88
SHIELD	1.0
ATLANTIC	0.76

## References

---

- [1] *High-Impact, Low-Frequency Event Risk to the North American Bulk Power System*, A Jointly-Commissioned Summary Report of the North American Reliability Corporation and the U.S. Department of Energy's November 2009 Workshop.
- [2] Application Guide: Computing Geomagnetically-Induced Current in the Bulk-Power System, NERC. December 2013. [http://www.nerc.com/comm/PC/Geomagnetic%20Disturbance%20Task%20Force%20GMDTF%202013/GIC%20Application%20Guide%202013\\_approved.pdf](http://www.nerc.com/comm/PC/Geomagnetic%20Disturbance%20Task%20Force%20GMDTF%202013/GIC%20Application%20Guide%202013_approved.pdf)
- [3] Boteler, D. H.; Pirjola R. J.; Liu, L.; and Zheng, K.; "Geoelectric Fields Due to Small-Scale and Large-Scale Source Currents." *IEEE Transactions on Power Delivery*, Vol. 28, No. 1, January 2013, pp. 442-449.
- [4] Boteler, D. H. "Geomagnetically Induced Currents: Present Knowledge and Future Research." *IEEE Transactions on Power Delivery*, Vol. 9, No. 1, January 1994, pp. 50-58.
- [5] Boteler, D. H. "Modeling Geomagnetically Induced Currents Produced by Realistic and Uniform Electric Fields." *IEEE Transactions on Power Delivery*, Vol. 13, No. 4, January 1998, pp. 1303-1308.
- [6] Gilbert, J. L.; Radasky, W. A.; and Savage, E. B. "A Technique for Calculating the Currents Induced by Geomagnetic Storms on Large High Voltage Power Grids." Electromagnetic Compatibility (EMC). 2012 IEEE International Symposium on.
- [7] *How to Calculate Electric Fields to Determine Geomagnetically-Induced Currents*. EPRI, Palo Alto, CA: 2013. 3002002149.
- [8] Pirjola, R.; Pulkkinen, A.; and Viljanen, V. Statistics of extreme geomagnetically induced current events, *Space Weather*, 6, S07001, doi:10.1029/2008SW000388, 2008.
- [9] Boteler, D. H. Assessment of geomagnetic hazard to power systems in Canada, *Nat. Hazards*, 23, 101–120. 2001.
- [10] Finnish Meteorological Institute's IMAGE magnetometer chain data available at: <http://image.gsfc.nasa.gov/>
- [11] Boteler, D. H. and Pirjola, R. J. The complex-image method for calculating the magnetic and electric fields produced at the surface of the Earth by the auroral electrojet. *Geophys. J. Int.*, 132(1), 31–40. 1998.
- [12] Coles, S. *An Introduction to Statistical Modelling of Extreme Values*. Springer. 2001.
- [13] Clarke, E.; McKay, A.; Pulkkinen, A.; and Thomson, A. April 2000 geomagnetic storm: ionospheric drivers of large geomagnetically induced currents. *Annales Geophysicae*, 21, 709-717. 2003.
- [14] Lindahl, S.; Pirjola, R. J.; Pulkkinen, A.; and Viljanen, A. Geomagnetic storm of 29–31 October 2003: Geomagnetically induced currents and their relation to problems in the Swedish high-voltage power transmission system. *Space Weather*, 3, S08C03, doi:10.1029/2004SW000123. 2005.
- [15] Beggan, C.; Bernabeu, E.; Eichner, J.; Pulkkinen, A.; and Thomson, A., Generation of 100-year geomagnetically induced current scenarios, *Space Weather*, Vol. 10, S04003, doi:10.1029/2011SW000750. 2012.

- [16] Crowley, G.; Ngwira, C.; Pulkkinen, A.; and Wilder, F. Extended study of extreme geoelectric field event scenarios for geomagnetically induced current applications. *Space Weather*, Vol. 11, 121–131, doi:10.1002/swe.20021. 2013.
- [17] Dawson, E.; Reay, S.; and Thomson, A. Quantifying extreme behavior in geomagnetic activity. *Space Weather*, 9, S10001, doi:10.1029/2011SW000696. 2011.

**Exhibit J**

**Consideration of Directives**

Consideration of Directives

*Reliability Standard for Transmission System Planned Performance for Geomagnetic Disturbance Events*

[Order No. 830](#), 156 FERC ¶ 61,215 (Sep. 22, 2016)

approving Reliability Standard TPL-007-1



## Consideration of Directives

#	P	Directive/Guidance	Resolution
1)	PP 44 47-49	<p><b>MODIFY THE BENCHMARK GMD EVENT re SPATIAL AVERAGING</b></p> <p>P44: “[T]he Commission, as proposed in the NOPR, directs NERC to develop revisions to the benchmark GMD event definition so that the reference peak geoelectric field amplitude component is not based solely on spatially-averaged data.”</p> <p>P47: “Without prejudging how NERC proposes to address the Commission’s directive, NERC’s response to this directive should satisfy the NOPR’s concern that reliance on spatially-averaged data alone does not address localized peaks that could potentially affect the reliable operation of the Bulk-Power System.”</p> <p>P48: “NERC could revise [the standard] to apply a higher reference peak geoelectric field amplitude value to assess the impact of localized hot spots on the Bulk-Power System, as suggested by the Trade Associations.”</p> <p>P49: “Consistent with Order No. 779, the Commission does not specify a particular reference peak geoelectric field amplitude value that should be applied to hot spots given present uncertainties.”</p>	<p>The directive is addressed in proposed TPL-007-2 through Requirements for applicable entities to perform supplemental geomagnetic disturbance (GMD) Vulnerability Assessments based on the supplemental GMD event. The supplemental GMD event is a defined event for assessing system performance that is not based on spatially-averaged data.</p> <p>The supplemental GMD event is described in the standard drafting team's (SDT) white paper available on the project page:</p> <p><a href="http://www.nerc.com/pa/Stand/Pages/Project-2013-03-Geomagnetic-Disturbance-Mitigation.aspx">http://www.nerc.com/pa/Stand/Pages/Project-2013-03-Geomagnetic-Disturbance-Mitigation.aspx</a></p>

## Consideration of Directives

#	P	Directive/Guidance	Resolution
2)	P65	<p><b>REVISE R6 RE SPATIAL AVERAGING</b></p> <p>P65: “Consistent with our determination above regarding the reference peak geoelectric field amplitude value, the Commission directs NERC to revise Requirement R6 to require registered entities to apply spatially averaged and non-spatially averaged peak geoelectric field values, or some equally efficient and effective alternative, when conducting thermal impact assessments.”</p>	<p>The directive is addressed in proposed TPL-007-2 Requirements R9 and R10. Applicable entities use geomagnetically-induced current (GIC) information for the supplemental GMD event to perform supplemental thermal impact assessments of applicable power transformers.</p> <p>Requirement R9 obligates responsible Planning Coordinators and Transmission Planners to provide GIC flow information to Transmission Owners and Generator Owners for performing supplemental thermal impact assessments. The GIC flow information is based on the supplemental GMD event.</p> <p>Requirement R10 obligates Transmission Owners and Generator Owners to perform supplemental thermal impact assessments on applicable power transformers and provide results to responsible Planning Coordinators and Transmission Planners.</p>

## Consideration of Directives

<p><b>3) PP 88</b> 90, 91, 92</p>	<p><b>REVISE STANDARD TO REQUIRE COLLECTION OF GMD DATA</b></p> <p>P 88: “The Commission ... adopts the NOPR proposal in relevant part and directs NERC to develop revisions to Reliability Standard TPL-007-1 to require responsible entities to collect GIC monitoring and magnetometer data as necessary to enable model validation and situational awareness, including from any devices that must be added to meet this need.</p> <p>The NERC standard drafting team should address the criteria for collecting GIC monitoring and magnetometer data discussed below and provide registered entities with sufficient guidance in terms of defining the data that must be collected, and NERC should propose in the GMD research work plan how it will determine and report on the degree to which industry is following that guidance.”</p> <p><i>GIC Requirements</i> P 91: “Each responsible entity that is a transmission owner should be required to collect necessary GIC monitoring data. However, a transmission owner should be able to apply for an exemption from the GIC monitoring data collection requirement if it demonstrates that little or no value would be added to planning and operations.</p> <p>In developing a requirement regarding the collection of GIC monitoring data, NERC should consider the following criteria discussed at the March 1, 2016 Technical Conference: (1) the GIC data is from areas found to have high GIC based on system studies; (2) the GIC data comes from sensitive installations and key parts of the transmission grid; and (3) the data comes from GIC monitors that are not situated near transportation systems using direct current (e.g., subways or light rail.”</p> <p><i>Magnetometer Requirements</i> P90: “In developing a requirement regarding the collection of</p>	<p>The directive is addressed in proposed TPL-007-2 Requirements R11 and R12.</p> <p>Requirement R11 obligates responsible Planning Coordinators and Transmission Planners to implement a process to obtain GIC monitor data from at least one GIC monitor located in the Planning Coordinator's planning area or other part of the system included in the Planning Coordinator's GIC System model. The SDT described GIC data collection criteria in the guidance section to promote consistency in achieving the reliability objective and provide responsible entities with flexibility to tailor procedures to their planning area. The guidance addresses the following considerations: monitor locations, monitor specifications, sampling interval, collection periods, data format, and data retention.</p> <p>Requirement R12 obligates responsible Planning Coordinators and Transmission Planners to implement a process to obtain geomagnetic field data for its Planning Coordinator’s planning area. Sources of geomagnetic field data include government observatories, installed equipment owned or operated by the entity, and third-party sources. Entities are referred to INTRAMAGNET guidance for criteria and considerations including data sampling rate (10-s or faster) and data format. By requiring responsible Planning Coordinators and Transmission Planners to obtain geomagnetic field data for their planning areas, the requirement ensures data is obtained from diverse geographic areas (latitudes and longitudes) of the North American Bulk-Power System.</p>
---	--	--

## Consideration of Directives

#	P	Directive/Guidance	Resolution
		<p>magnetometer data, NERC should consider the following criteria discussed at the March 1, 2016 Technical Conference: (1) the data is sampled at a cadence of at least 10-seconds or faster; (2) the data comes from magnetometers that are physically close to GIC monitors; (3) the data comes from magnetometers that are not near sources of magnetic interference (e.g., roads and local distribution networks); and (4) data is collected from magnetometers spread across wide latitudes and longitudes and from diverse physiographic regions.”</p> <p style="text-align: center;">***</p> <p>P 91: GIC monitoring and magnetometer locations should also be revisited after GIC system models are run with improved ground conductivity models. NERC may also propose to incorporate the GIC monitoring and magnetometer data collection requirements in a different Reliability Standard (e.g., real-time reliability monitoring and analysis capabilities as part of the TOP Reliability Standards).</p> <p>P 92: “[T]he Commission determines that requiring responsible entities to collect necessary GIC monitoring and magnetometer data, rather than install GIC monitors and magnetometers, affords greater flexibility while obtaining significant benefits.”</p>	

## Consideration of Directives

4)	<b>P 101, 102</b>	<p><b>REVISE TPL-007 TO REQUIRE DEADLINES FOR THE DEVELOPMENT AND COMPLETION OF CORRECTIVE ACTION PLANS</b></p> <p>P 101: “The Commission directs NERC to modify Reliability Standard TPL-007-1 to include a deadline of one year from the completion of the GMD Vulnerability Assessments to complete the development of corrective action plans.”</p> <p>P 102: “The Commission also directs NERC to modify Reliability Standard TPL-007-1 to include a two-year deadline after the development of the corrective action plan to complete the implementation of non-hardware mitigation and four-year deadline to complete hardware mitigation...”</p>	<p>The directive is addressed in proposed TPL-007-2 Requirement R7.</p> <p>Part 7.2 specifies that responsible entities must develop Corrective Action Plans (CAP) within one year of completing the benchmark GMD Vulnerability Assessment.</p> <p>Part 7.3 requires responsible entities to include a timetable in the CAP that must specify:</p> <ul style="list-style-type: none"> <li>• Specify implementation of non-hardware mitigation, if any, within two years of development of the CAP; and</li> <li>• Specify implementation of hardware mitigation, if any, within four years of development of the CAP.</li> </ul> <p>Part 7.4 provides responsible entities with flexibility to revise the CAP and timetables if situations beyond the control of the responsible entity prevent implementation of the CAP within the specified timetable. The provision is necessary to account for potential planning, siting, budgeting approval, or regulatory uncertainties associated with transmission system projects that are not within the responsible entity’s control. Responsible entities are obligated to document the revised CAP and update the revised CAP every 12 calendar months until implemented.</p> <p>Requirement R8 requires responsible entities to complete a supplemental GMD Vulnerability Assessment, based on the supplemental GMD event, to evaluate localized enhancements of geomagnetic field during a severe GMD event that could potentially affect</p>
----	-------------------	--	---

## Consideration of Directives

			<p>the reliable operation of the Bulk-Power System. Localized enhancements of geomagnetic field can result in geoelectric field values above the spatially-averaged benchmark in a local area. Part 8.3 specifies that if the responsible entity concludes that there is Cascading caused by the supplemental GMD event, then the responsible entity shall conduct an analysis of possible actions to reduce the likelihood or mitigate the impacts and the event.</p> <p>Proposed TPL-007-2 does not require responsible entities to implement a Corrective Action Plan to address impacts identified in the supplemental GMD Vulnerability Assessment because mandatory mitigation on the basis of the supplemental GMD Vulnerability Assessment may not provide effective reliability benefit or use industry resources optimally. As discussed in the Supplemental GMD Event Description white paper, the supplemental GMD event is based on a small number of observed localized enhancement events that provide only general insight into the geographic size of localized events during severe solar storms. Additionally, the state-of-the-art modeling tools do not provide entities with capabilities to realistically model localized enhancements within a severe GMD event, and as a result entities may need to employ conservative approaches in the GMD Vulnerability Assessment such as applying the localized peak geoelectric field over an entire planning area.</p> <p>The approach taken in TPL-007-2 to mitigating impacts identified in the supplemental GMD Vulnerability Assessment provides responsible entities with flexibility to consider and select actions based on entity-specific</p>
--	--	--	--

## Consideration of Directives

#	P	Directive/Guidance	Resolution
			factors. This is similar to the approach taken in Reliability Standard TPL-001-4 for extreme events (TPL-001-4 Requirement R3 Part 3.5).